

MINI-MAG SERIES

MINI-MAG

Operator Manual

2009 Version 1.0

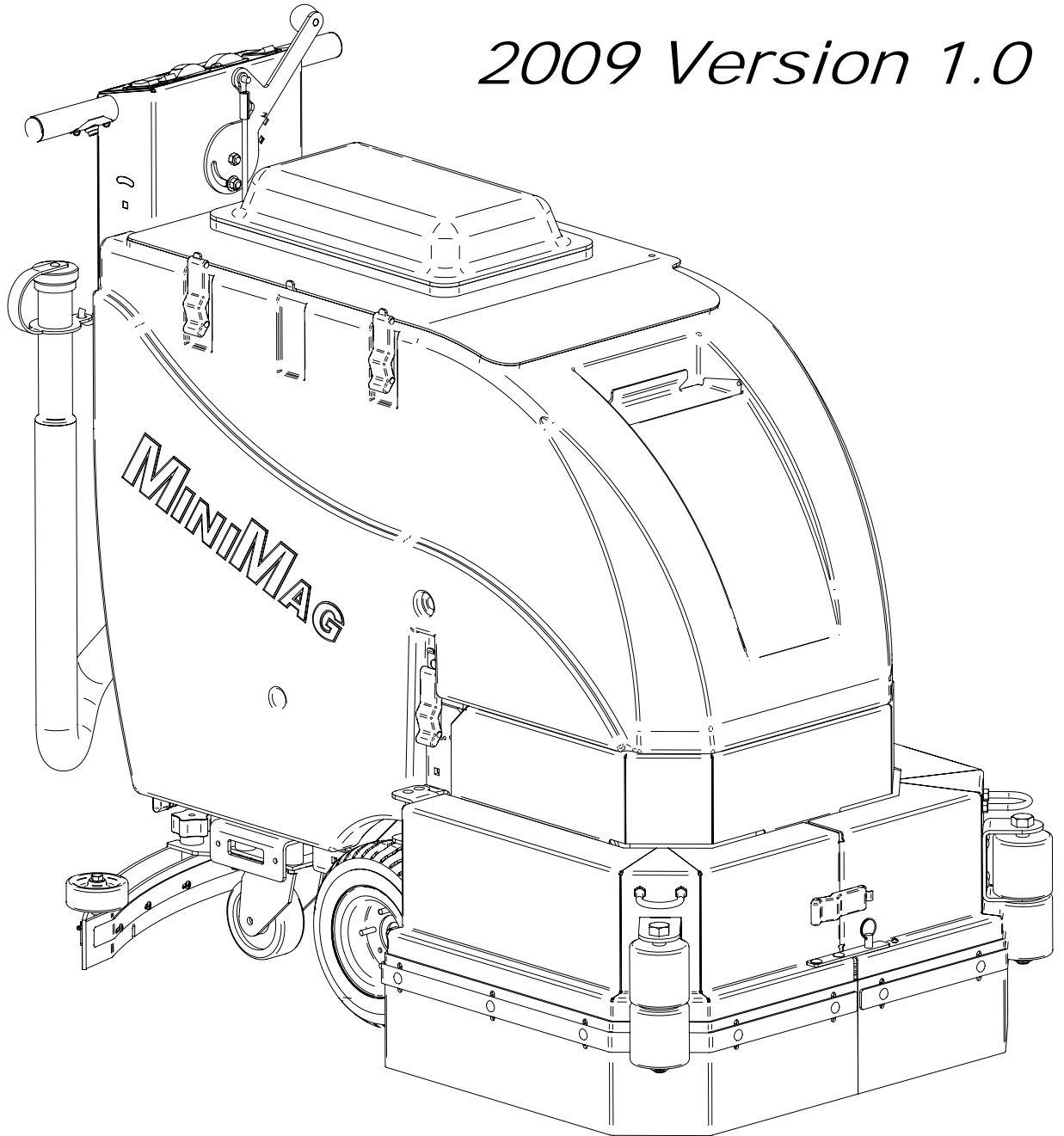

R.P.S. Corporation
P.O. Box 241
Racine, Wisconsin 53401

Phone: 1-800-450-9824
Fax: 1-866-632-6961

HOW TO USE THIS MANUAL

This manual contains the following sections:

- **HOW TO USE THIS MANUAL**
- **SAFETY**
- **OPERATIONS**
- **MAINTENANCE**
- **PARTS LIST**

The **HOW TO USE THIS MANUAL** section will tell you how to find important information for ordering the correct replacement parts.

Parts may be ordered from authorized dealers. When placing an order for parts, the machine model and serial number are important.

Refer to **MACHINE INFORMATION** on page one of this manual, which is filled out during the installation of your machine.

The serial number of your machine is located on the lower half of the control panel of the machine. (See Picture Below)



Serial Number

The **SAFETY** section contains important information regarding hazard or unsafe practices of the machine.

Levels of hazards are identified that could result in product or personal injury, or severe injury resulting in death.

The **OPERATIONS** section is to familiarize the operator with the operation and function of the machine.

The **MAINTENANCE** section contains preventative maintenance to keep the machine and its components in good working condition. They are listed in this general order:

- Batteries
- Scrub Brushes
- Adjusting Squeegee
- Service Schedule
- Machine Trouble Shooting

The **PARTS LIST** section contains assembled parts illustrations and corresponding parts list. The parts lists include a number of columns of information:

- **ITEM** - Column refers to the reference number on the parts illustration.
- **PART NO.** - Column lists the part number for the part.
- **QTY** - Column lists the quantity of the part used in that area of the machine.
- **DESCRIPTION** - Column is a brief description of the part.
- **COMMENTS** - Column for information not noted by the other columns.

NOTE: If a service or option kit is installed on your machine, be sure to keep the **KIT INSTRUCTIONS** which came with the kit. It contains replacement part numbers needed for ordering future parts.

* As our policy is one of constant improvement, all information and specifications are subject to change without notice. *



Industrial • Commercial • Environmentally Safe

TRADITIONAL DRUMS / TOTES



DEMO / RENTAL QUARTS



WALL-MOUNTED SUPERCON



ONBOARD AUTO DISPENSING



Onboard
Availability

FORMULAS

SUDS
Approved



707 Citrus Green An environmentally cleaner that works! It is a solvent free degreaser that works on oil, carbon, even rubber marks. Incorporates the latest technology in "Green Cleaning".

SUDS
Approved



733 Low pH Safe on most surfaces not harmed by water alone. Low scale formula to prevent alkali buildup in cleaning equipment, while offer detergent to emulsify oil.

SUDS
Approved



755 High Power Ideal solvent fortified degreaser. This butyl based detergent is penetrating, fast acting, and deep cleaning with built-in corrosion inhibitors. It is our most effective degreaser.

SUDS
Approved



757 Gloss A high gloss detergent designed to dry to a bright shine. It is ideal for use on finished surfaces, tile, epoxy, or enamel. The special formula removes salt residue, scuff marks and dirt, while leaving no residue behind. The result is a clean, non-slip surface, ready for immediate use.

SUDS
Approved



797 HD The Heavy Duty concentrate is a Super alkaline detergent, formulated for heavy soil, grease, and thick buildup. Popular in machine shops, auto and truck repair, and other facilities with oil, hydraulic fluids and cutting oils.

***Below Sold in bulk concentrate only. Not available as a SuperCon, PowerDose or SUDS product.*

727 Pretreat** Designed to quickly remove tire marks, oil stains and buildup that has accumulated. This pretreat uses the powerful cleaning of natural citrus extract and is intended to be used directly on the floor at 100% concentrate.

744 Tough Stuff** Ideal for applications with Hard Water problems. It is safe to use in pressure washers and automatic scrubbers. The formulation enhances soil suspension, digests oil and grease, while supporting extra water conditioner.

PowerCat
P.O. Box 503
Racine, WI 53404-0503
Phone: 414-745-9337
Fax: 262-632-1630
www.powercatsolutions.com

Distributed by:

PowerCat, LLC, 2008.

TABLE OF CONTENTS

MACHINE INFORMATION FORM	PAGE 1
WARRANTY REGISTRATION FORM	PAGE 2
MACHINE SPECIFICATIONS	PAGE 3
COMMON WEAR PARTS	PAGE 4
SAFETY MESSAGES	PAGE 5
!!SAFETY PRECAUTIONS!!	PAGE 6
MACHINE CONTROLS AND FEATURES	PAGE 7-8
MACHINE SETUP	PAGE 9
ADJUSTING & REMOVING SQUEEGEE	PAGE 10
INSTALLING PAD DRIVER OR BRUSH	PAGE 11
INSTALLING CYLINDRICAL BRUSHES	PAGE 12
MACHINE OPERATION	PAGE 13-15
ADJUST SOLUTION FLOW & CURTAINS, DRAINING TANKS	PAGE 16
CLEANING RECOVERY TANK	PAGE 17
TIP TANK, RAISE & LOWER SQUEEGEE	PAGE 18
ADJ. DECK HEIGHT, VAC MOTOR & SOLUTION FILTER	PAGE 19
CHARGING BATTERIES	PAGE 20
ON-BOARD BATTERY CHARGER "OPTIONAL"	PAGE 21-24
MAINTENANCE & STORING MACHINE	PAGE 25
PREVENTATIVE MAINTENANCE RECORDS	PAGE 26-27
LCD SCREEN MENU DISPLAY'S	PAGE 28
TROUBLESHOOTING	PAGE 29-32

MACHINE INFORMATION

Please fill this area out at the time of installation for future reference.

Model Number: _____

Serial Number: _____

Installation Date: _____

Installing Dealer: _____

Dealer Contact: _____

Address: _____

City, State, Zip: _____

Phone Number: _____

This operator and parts manual should be considered a permanent part of the unit and should remain with the unit at all times. This operator and parts manual covers all the Mini-Mag series scrubbers. You may find descriptions and features that are not on your particular model. The information and specifications included in this publication were in effect at the time of printing. R.P.S. Corp. reserves the right to make changes without notice or incurring any obligation.

To register for warranty, fax your warranty registration form today!

FAX # (886)-632-6961

MACHINE DELIVERY FORM

Dealer: _____

Installed By: _____

Location: (City, State) _____

Install Date: _____

Customer Information

Name: _____

Contact: _____

Address: _____

City/State: _____ Zip _____

Phone Number : _____

Fax Number: _____

Model Number: _____ Serial Number: _____ Hour Meter: _____

Squeegee Size: _____ Squeegee Material: Gum Linatex Neoprene (circle one)

Buyer's representative has received instruction in proper operation of the following controls and features:

- Filling Solution Tank, Solution Tank Sight Tube, Solution Drain Valve
- Adjusting Controls and "Uni-Touch" operation, Double Scrubbing, Squeegee Delay & Vac Timer
- Recovery Tank Draining and Cleaning, Vac Screen Removal and Cleaning
- Shroud and Pad Removal
- Shroud Adjustment
- Solution Valve and Filter Operation (removal and cleaning)
- Drain Saver Feature
- Charging Operation
- Seat and Steering Wheel Adjustment
- LCD Screen Display Operation, 3 Hour Meters (keyswitch, brush, traction drive)
- Tank Tilt Back Feature
- Parking Brake Override
- Checking Battery Electrolyte Level
- Squeegee Hose Removal and Checking For Clogs
- Battery Guide Poster Hung Up & Reviewed
- Maintenance Guide Poster Hung Up & Reviewed

In addition to the items listed above the buyers representative has received the operator's manual and been advised to read the manual before operating the machine.

Installed By (print) _____ Signature _____

Buyer's Representative (print) _____ Signature _____

BUYER AGREES TO PAY FOR ANY REPAIRS, ADJUSTMENTS, OR SECONDARY TRAINING THAT MANUFACTURER DETERMINES IS EXCLUDED FROM THE WARRANTY

COMPLETE AND FAX FORM to 866-632-6961

MACHINE SPECIFICATIONS

MINI (Brush Drive)

MINIMAG (Traction)

BODY / DIMENSIONS

Tank Material:	Poly (3/8" thick)	Poly (3/8" thick)
Chassis Construction:	1/8" Coated Steel	1/8" Coated Steel
Front Wheels:	(2) 9" x 2"	(2) 9" x 3"
Rear Casters:	(2) 4" x 2"	(2) 4" x 2"
Size (L x W x H):	45" x 18" x 40"	48" x 18" x 40"
Weight (w/batteries)	374 lbs	387 lbs

BRUSHSYSTEM

Disk Brush/Pad Size:	17-BD: (1) 17" 20-BD: (1) 20" 23-BD: (1) 23"	17-TD: (1) 17" 20-TD: (1) 20" 23-TD: (1) 23" 26-TD: (2) 13"
Disk Brush Motor (Single Disk):	(1) 1.0 hp / 200 rpm	(1) 1.0 hp / 200 rpm
Disk Brush Motor (Twin Disk 26"):		(2) 0.75 hp / 270 rpm
Cylindrical Brush Size:		24-FC (2) 22"
Cylindrical Brush Motor:		(2) 0.75 hp / 350 rpm
Brush Down Pressure:	0 – 125 pounds	0 - 150 pounds

BATTERY SYSTEM:

System Voltage	24 volts	24 volts
Standard Battery Rating:	115 ah	115 ah
Optional Battery Rating:	165 ah	165 ah
Battery Run Time:	Up to 3.5 hours	Up to 3.5 hours
Charger (110-v / 60 Hz / 24-volt):	Onboard / Automatic	Onboard / Automatic

DRIVE SYSTEM

Standard Drive:	Brush Drive	0.5 hp, all gear / sealed
Forward Speed:	0-230 ft/min (4 mph)	0-230 ft/min (4 mph)
Reverse Speed:	0-130 ft/min (2 mph)	0-130 ft/min (2 mph)

SOLUTION SYSTEM:

Solution Tank Cap.:	17 gallons	17 gallons
Solution Flow Rate:	0 - 1.0 gpm	0 - 1.0 gpm
Solution Filter:	Stainless / Inline	Stainless / Inline

RECOVERY SYSTEM:

Recovery Tank Cap.:	17 gallons	17 gallons
Vac. Power:	0.75 hp	0.75 hp
Drain Hose:	1.5" diameter	1.5" diameter
Vacuum Specs (lift / airflow):	68" / 70 cfm	68" / 70 cfm
Demisting Chamber:	1.25 gallons	1.25 gallons
Drain Saver:	30 cubic inches	30 cubic inches

GENERAL:

Cleaning Width:	17-BD: 17" 20-BD: 20" 23-BD: 23"	17-TD: 17" 20-TD: 20" 23-TD: 23" 26-TD: 26" 24-TC: 24"
Cleaning Rate/Hour (Sq.Ft/Hr):	Up to 22,124	Up to 25,543
Sound Level:	70 dBA @ Operator's Position for all units	

AUTHORIZED DISTRIBUTOR

RPS CORPORATION
P.O. Box 368
Racine, WI 53401
Phone: (800) 634-4060
Fax: (866) 901-3335

www.factorycat.com

www.tomcatequip.com

Copyright RPS Corporation 2006. All right reserved. Since our policy is one of constant improvement, all specifications are subject to change without notice.

COMMON WEAR PARTS

BRUSHES	MODEL	MODEL	MODEL	MODEL	MODEL	MODEL
	17"-DISK	20"-DISK	23"-DISK	26"-DISK	24"-CYL NEW STYLE	24"-CYL OLD STYLE
SUPER-GRIT	17-421SS	20-421SS	23-421SS	13-421SS	N/A	N/A
TOUGH-GRIT	17-421S	20-421S	23-421S	13-421S	225-821S	22-521S
MIDI-GRIT	17-421C	20-421C	23-421C	13-421C	225-821C	22-521C
LIGHT-GRIT	17-421PS	20-421PS	23-421PS	13-421PS	225-821PS	22-521PS
POLY (.028)	17-421P	20-421P	23-421P	13-421P	N/A	N/A
NYLON (.016)	17-421N	20-421N	23-421N	13-421N	225-821N	22-521N
TAMPICO	17-421T	20-421T	23-421T	13-421T	N/A	22-521T
PAD DRIVER	17-421D	20-421D	23-421D	13-421D	N/A	N/A
DIAMOND DRIVER	17-421DD	20-421DD	N/A	N/A	N/A	N/A

BRUSH P/N FOR MACHINES WITH SERIAL #50000 & GREATER
REF: CYL DOOR ASSEMBLY

BRUSH P/N FOR MACHINES PRIOR TO SERIAL #50000
REF: CYL DOOR ASSEMBLY

NOTE: # In Disk Column Denotes Pad Size: 13,17, 20, 23

PADS	DISK	LEVEL	COLOR
SUPER BLACK	##422BB	VERY HIGH	BLACK
BLACK	##422B	HIGH	BLACK
BROWN	##422BR	HIGH	BROWN
GREEN	##422G	MEDIUM	GREEN
BLUE	##422BL	MODERATE	BLUE
RED	##422R	MODERATE	RED
WHITE	##422W	LIGHT	WHITE

EXTRA PAD DRIVER RETAINING CLIP: 40-433

BRUSH REPAIR KIT: 40-423 REPLACEMENT LOCATING CLIP FOR ALL DISK BRUSHES.

<u>SQUEEGEE SIZE'S</u>	<u>GUM RUBBER</u>	<u>LINATEX</u>
32" SQUEEGEE "STANDARD" ON ALL MACHINES.	22-770G	22-770L
35" SQUEEGEE "OPTIONAL"	25-770G	25-770L

Note: Squeegee Assemblies (complete) listed below all come with Linatex blades.

SIZE	P/N
32"	23-7180
35"	25-7180

SOAP

Heavy Duty Degreaser

Citrus

Freezer

Tire Mark Remover

For more soap information call PowerCat 414-745-9337

www.powercatsolutions.com

Kit Includes: (1) Rear Blade, (1) Front Blade, and (2) Backup Wheels with hardware.

Note: Size is stamped into the top of the painted steel squeegee blank on 32", 35" squeegees.

Note: The Squeegee is designed for narrow isles and may not have the same water control around tight turns as the larger squeegees.

SAFETY MESSAGES

Your safety, and the safety of others, is very important, and operating this unit safely is an important responsibility.

To help you make informed decisions about safety, we have provided operating procedures and other safety information in the manual. This information informs you of potential hazards that could hurt you or others.

It is not practical or possible to warn you of all the hazards associated with operating this unit. You must use your own good judgment.

This machine is intended for commercial use. It is designed to be used on hard floors in an indoor environment, with the recommended pads or brushes.

1. DO NOT OPERATE UNIT:

Unless trained and authorized.
Unless operator manual is read and understood.
If unit is not in proper operating condition.

2. WHEN OPERATING UNIT:

Remove loose objects from the floor that may be projected from the revolving brushes.
Keep hands and feet away from revolving brushes.
Do not operate machine where flammable liquids are present.
Use extreme caution when maneuvering.

3. BEFORE LEAVING:

Drain Tanks
Make sure machine is turned off.
Stop on level surfaces.
Disconnect batteries.

4. BEFORE SERVICING:

Stop on level surface, and secure machine.
Disconnect batteries.

!! SAFETY PRECAUTIONS!!

WARNING: Hazardous voltage. Shock, burns or electrocution can result. Always disconnect the batteries before servicing machine.

WARNING: Batteries emit hydrogen gases. Explosion or fire can result. Keep sparks and open flames away.

WARNING: Charge unit in a well ventilated area, and keep battery compartment open when charging. Explosion or fire could result.

WARNING: Battery acid can cause burns. Wear protective eye wear and gloves when servicing batteries.

WARNING: Do not store outdoors or pressure wash. Prevent electronic components from getting wet.

WARNING: The use of parts and solutions other than that recommended by the manufacturer may cause damage or endanger people.

WARNING: Dress safely. Do not wear rings or metal wrist watches while working on this machine. They can cause an electrical short, which, can cause serious burns. Do not work on this machine while wearing a tie, scarf or other loose, dangling neckware or clothing. These loose items can tangle in the rotating parts and cause serious injury or even death.

WARNING: Do not use the machine as a step ladder or chair.

WARNING: Only operate this machine from the operators position. It was not designed to carry passengers.

WARNING: Do not operate this machine on ramps or uneven surfaces. When climbing a ramp, always drive the machine in forward straight up or down the ramp. Never drive across the incline. Do not back down or turn on ramps!

WARNING: Always use the charger provided by the manufacturer to charge the machine. It is an automatic charger, specifically designed to charge at the appropriate rate. If you must use a different charger, disconnect the batteries before charging. This will prevent damage to the electronic speed controller.

WARNING: Understand the dynamic braking system before you operate the machine on ramps. Machine may coast.

WARNING: Do not park the machine on ramps or slopes.

WARNING: Do not operate the machine if any parts have been removed or damaged.

WARNING: Do not remove, paint over, or destroy warning decals. If warning decals become damaged, they must be replaced.

WARNING: Do not operate machine in unsafe condition. If the machine is in need of repair or is in any way unsafe to operate, the matter should be reported immediately to the shift supervisor. Do not operate the machine until it is returned to proper operating condition.

WARNING: This machine must only be operated by trained operator. As part of his or her training, they must read this manual thoroughly. If extra copies are needed, contact your local dealer.

WARNING: Always turn off the machine, before leaving it unattended.

WARNING: Do not operate over electrical floor outlets. May result in serious injury.

MACHINE CONTROLS AND FEATURES

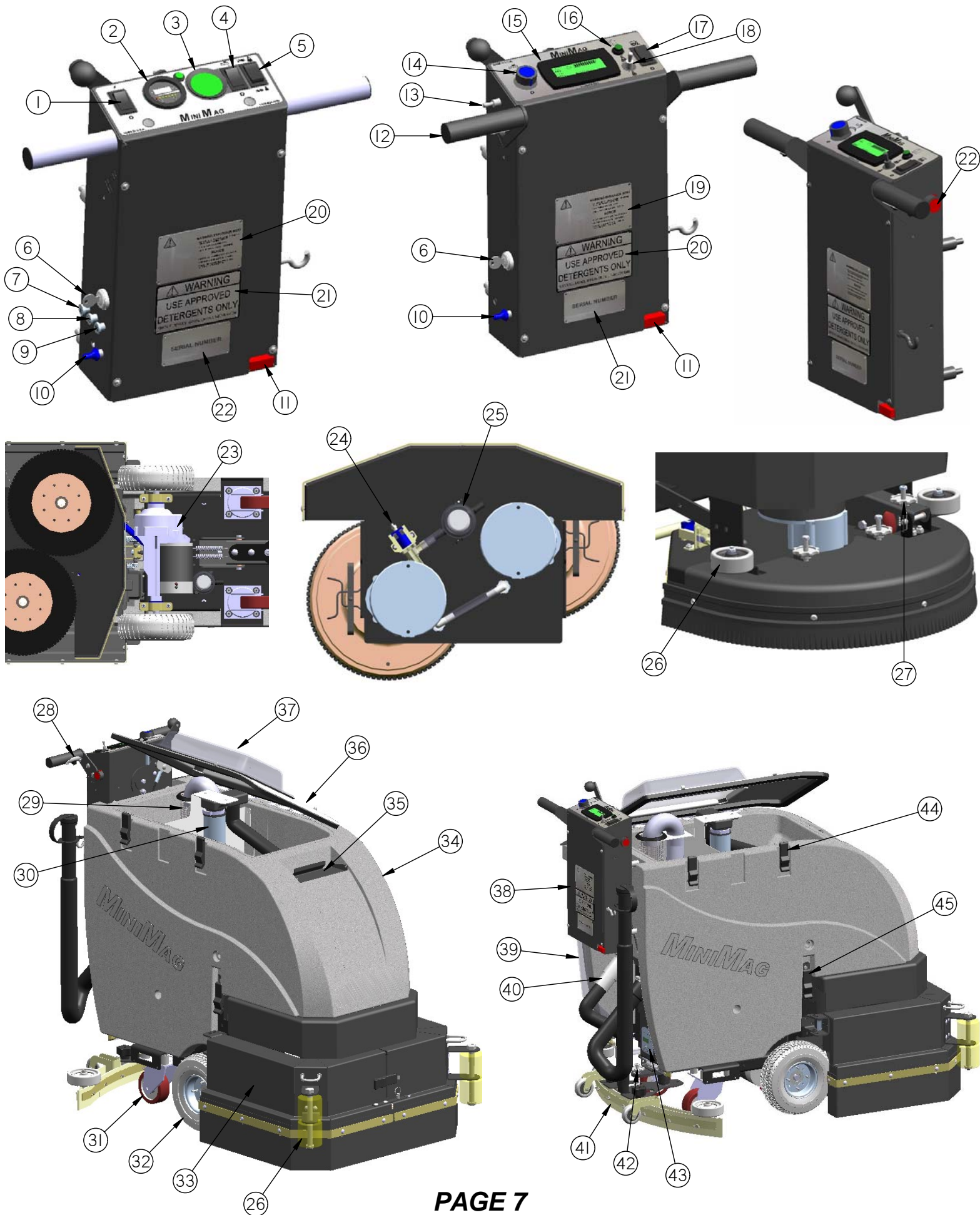

CONTROLS AND FUNCTIONS

1. **MAIN POWER SWITCH:** Turns the machine on and off.
2. **BATTERY GUAGE/HOUR METER:** Indicates the amount of battery charge remaining.
3. **SCRUBDECK DOWN PRESSURE GUAGE:** Indicates the amount of down pressure being applied to scrubdeck.
4. **SOLUTION FLOW SWITCH:** Turns solution flow on.
5. **SCRUBDECK SWITCH:** Raises and lowers the scrubdeck and controls amount of down pressure being applied.
6. **KEY SWITCH:** Turns power on to the machine. (Standard on Traction Drive, Optional on Brush Drive.)
7. **CIRCUIT BREAKER:** 2 AMP resettable circuit breaker.
8. **CIRCUIT BREAKER:** 25 AMP resettable circuit breaker.
9. **CIRCUIT BREAKER:** 40 AMP resettable circuit breaker.
10. **SPRAY JET (BLUE) (OPTIONAL):** Activates Spray Pump for remote Spray Wand.
11. **CHARGER PORT:** Red 50 used to receive charger input for optional external charger.
12. **HANDLE BAR:** Adjustable Handle Bar
13. **REVERSE SWITCH:** Pull back for reverse.
14. **SOLUTION FLOW CONTROL KNOB:** Turn clock-wise to reduce, counter-clockwise to increase solution flow.
15. **LCD SCREEN:** Lists functions and settings of the machine.
16. **MENU CONTROL:** Scrolls through different options on the LCD display, there are three different screens.
17. **SCRUBDECK SWITCH:** Raises and lowers the scrubdeck.
18. **DOWN PRESSURE TOGGLE SWITCH:** Controls the pressure to the scrubdeck, push forward for more down pressure.
19. **WARNING PLATE:** Explosion warning.
20. **WARNING PLATE:** Detergent/Water warning.
21. **SERIAL NUMBER PLATE:** Machine identification.
22. **SPEED CONTROL KNOB:** Controls the speed of the Traction Drive. Turn counter-clockwise to reduce speed.
23. **TRACTION DRIVE:** Propels machine forward/backward.
24. **SOLUTION FLOW VALVE:** Controls solution flow rate.
25. **SOLUTION FILTER:** Filters water solution prior to scrubbing.
26. **WALL ROLLERS:** Helps protect machine when scrubbing near walls.
27. **"PAD ASSIST" DRIVE ADJUSTMENT KNOB:** Adjusts amount of offset being applied to brush.
28. **DRIVE BUTTON:** Depress to drive forward, release to stop. (starts & stops the drive motor)
29. **"DRAIN SAVER" STRAINER:** Helps prevent clogging of drain ports.
30. **VAC SCREEN:** Protects Vac Motor from debris.
31. **CASTER:** Twin casters for stability.
32. **MAIN TIRE:** Drive Tires.
33. **JAWS:** Protects Scrubdeck from collision damage.
34. **TANK-IN-TANK:** Solution/Recovery Tank (17 gallon capacity each).
35. **SOLUTION FILL LID:** Fill port for filling Solution Tank.
36. **RECOVERY LID:** Used for flushing out Recovery Tank area with fresh water.
37. **CLEAR COVER:** For viewing inside Recovery Tank area.
38. **CONTROL PANEL:** Machine controls and access to electrical components.
39. **SOLUTION LEVEL INDICATOR & DRAIN TUBE:** Shows precise level of cleaning solution in Tank & Drain Port.
40. **VACUUM HOSE:** Vacuumizes Squeegee. **NOTE:** Keep free and clear of blockage.
41. **SQUEEGEE BLADE:** Recovers dirty water from floor to be recovered by Vacuum Hose.
42. **SQUEEGEE PITCH ADJUSTMENT:** Adjusts pitch of Squeegee. Deflection should be even across entire blade.
43. **"ON BOARD" BATTERY CHARGER:** Recharges Batteries.
44. **RECOVERY DRAIN HOSE:** Allows for controlled draining of Recovery Tank.
45. **TANK LATCH:** Secures tank to frame.

MACHINE SETUP

UNCRATING MACHINE

CAREFULLY CHECK THE CRATE FOR ANY SIGNS OF DAMAGE AND THAT THE BATTERIES ARE IN THE UNIT.

TO UNCRATE THE MACHINE, REMOVE BANDING FROM AROUND THE CRATE. TAKE OFF THE TOP AND SIDES AND DISPOSE OF PROPERLY. REMOVE BRACKETS (A) FROM MACHINE WHEELS. REMOVE BOLTS (B) FROM PALLET THEN REMOVE BOARD (C). CAREFULLY ROLL THE MACHINE OFF OF THE BASE. **NOTIFY THE CARRIER IMMEDIATELY IF CONCEALED DAMAGE IS DISCOVERED.** (SEE BELOW)



ATTACHING SQUEEGEE

1. Lower the squeegee mounting plate by rotating the lift lever "A" clockwise. (SEE BELOW)

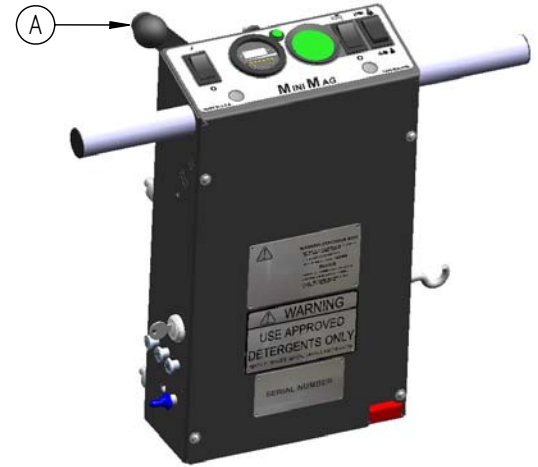

2. Loosen the two knobs "B" on the squeegee and slide them into the slots in the squeegee mounting plate. (SEE BELOW)

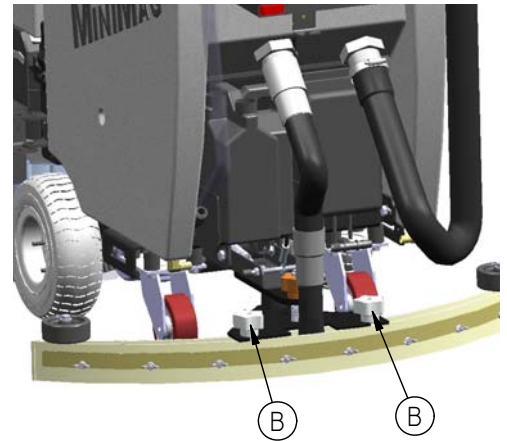

2. Tighten the two knobs, and connect the vacuum hose "C" from the machine to the squeegee. (SEE BELOW)

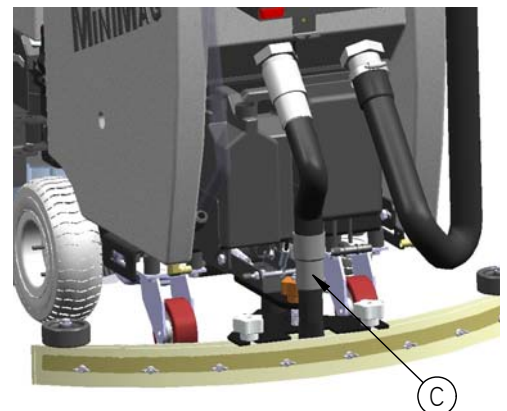

4. You may have to adjust the squeegee pitch. (SEE ADJUSTING SQUEEGEE ON NEXT PAGE.)

CONNECTING BATTERIES

Your machine is equipped with (2) 12-volt/115 AH, or (2) 12-volt/165 AH, Deep Cycle, Batteries, which form a 24 volt system.

(SEE PICTURE BELOW FOR CORRECT CABLE CONNECTIONS.)

1. Turn all switches to the off position and remove key (if machine is equipped with optional key switch).
2. Turn on main power switch and check the battery condition meter to ensure correct installation. Charge batteries if needed. (SEE BATTERY CHARGING.)

WARNING! Batteries are a possible environmental hazard. Consult your battery supplier for safe disposal methods.

NOTE: Orientation of batteries is critical for cables to reach!

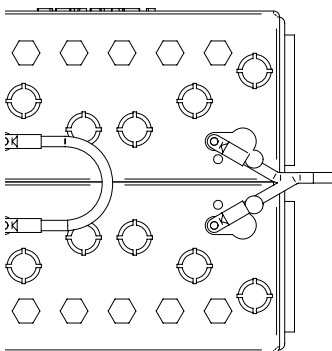

24-Volts

BATTERY CABLE CONNECTIONS

ADJUSTING SQUEEGEE

1. Turning adjustment knob "A" clock-wise (tightening) will lower tips & raise center. (SEE PICTURE BELOW.)

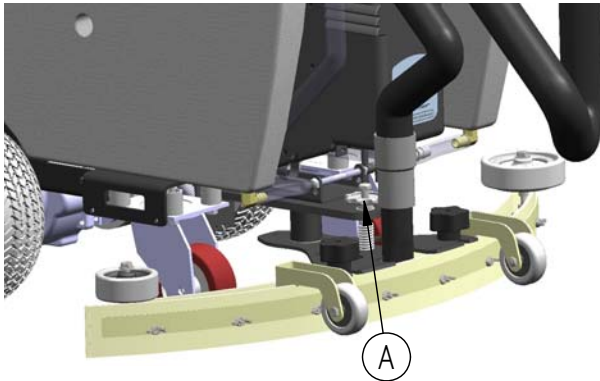

2. This squeegee is adjusted too far back and will not pick up on the corners. **note tips off the floor**. (SEE BELOW)



3. This squeegee is adjusted too far forward and will not pick up in the center. **note center spaced off the floor**. (SEE BELOW)

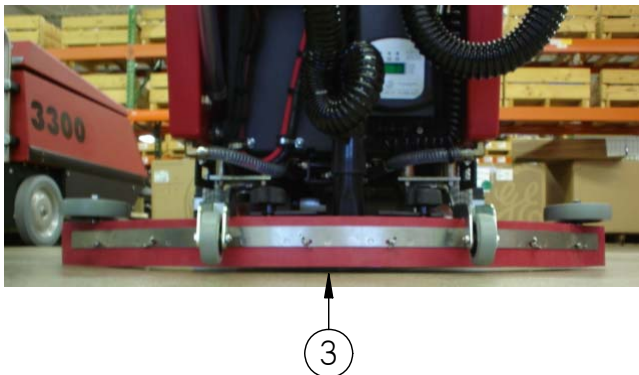

4. This squeegee is adjusted just right with good deflection across the entire rear blade. (SEE BELOW)



REMOVING SQUEEGEE

1. With the squeegee in the up position, turn machine power off.
2. Disconnect vacuum hose "A" from squeegee and loosen both knobs "B". (SEE BELOW)
3. Pull squeegee assembly rearward from the lifting carrier.
4. Inspect or repair as needed and reinstall.

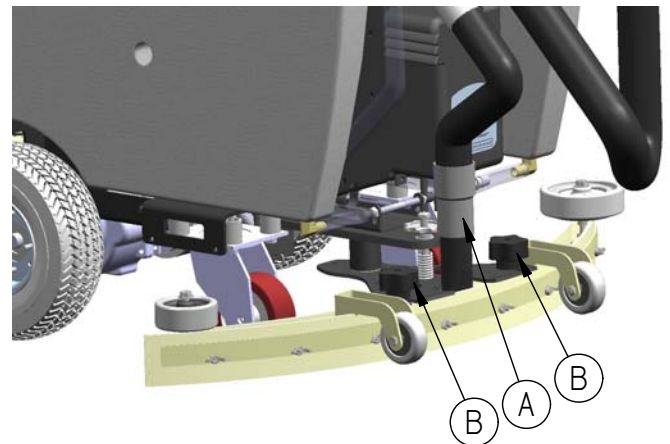

REPLACING OR ROTATE SQUEEGEE BLADES

FOR SAFETY: Before leaving or servicing machine stop on level surface, turn off machine and remove key.

1. Remove the squeegee assembly from the machine. Remove blade retainer strap and remove squeegee blade.
2. Rotate the squeegee to new edge position or replace as required.
3. Install blade on the locating pins of squeegee assembly.
4. Install squeegee retainer strap.
5. Fasten and lock knobs.

INSTALLING DISK PAD DRIVER OR BRUSH

1. Turn on machine power.
2. Raise the scrub deck by depressing the brush switch (O) to the up and off position and turn machine power back off.
3. The machine is equipped with jaws. Remove pin "A" and undo latch "B" on front of jaws to open them. *(SEE BELOW)*
4. Select the correct pads or brushes that best meet your cleaning application. Consult your local dealer for assistance.
5. Pad installation: attach pads to pad drivers before connecting drivers to motor hub. center clip "C" should click twice. *(SEE BELOW)*

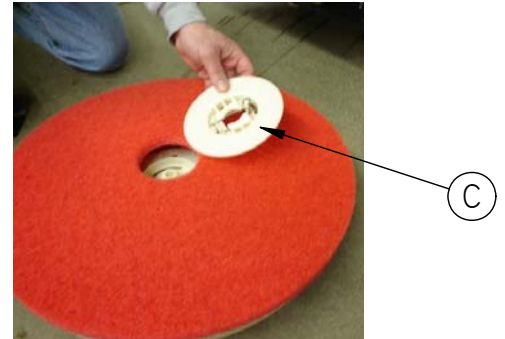
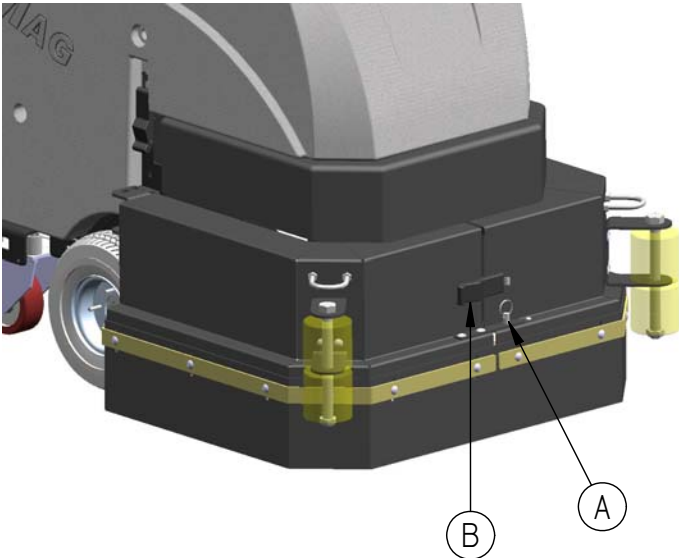

6. Attach brushes or pads to motor hubs. Squeeze the scissor locking device and lift brush up on to the motor drive hub. Make sure the scissors close and lock once the brushes are on. *(SEE BELOW)*



7. With brushes locked in place, close jaws, secure latch and insert pin.

SCRUB BRUSHES

There are many different types of brushes available to cover applications from cleaning heavily soiled floors to polishing. A pad driver is also available to take advantage of the many cleaning pads on the market. Please refer to the "**COMMON WEAR PARTS**" page to assist in selecting the proper brush or pad for the work at hand.

*****FOR CORRECT PAD APPLICATION, CALL YOUR LOCAL DEALER*****

INSTALLING CYLINDRICAL BRUSHES

1. Turn on machine power.
2. Raise the scrub deck by depressing the brush switch (O) to the up and off position and turn machine power back off.
3. Disconnect batteries.
3. Remove side access door on each side of scrubdeck by depressing latch button "A" and unscrewing thumb screw "B". *(SEE BELOW)*

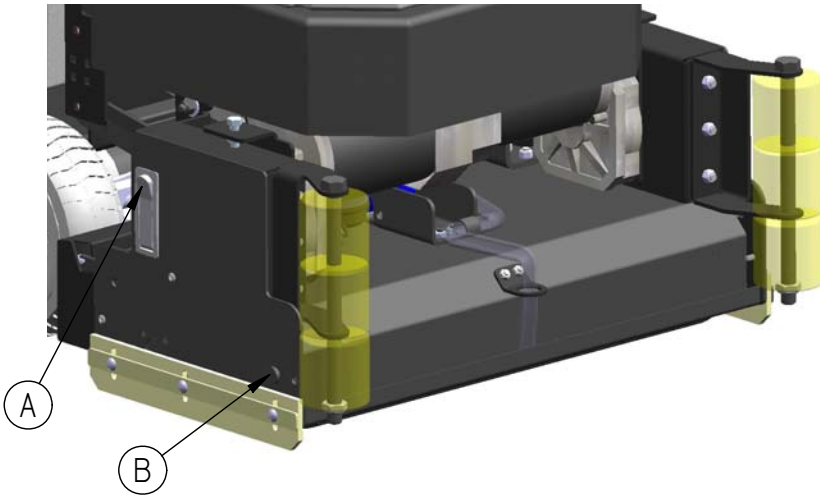

4. Slide brush "C" in onto brush driver on opposite side and spin until you feel it catch and drop in. *(SEE BELOW)*
5. When the brushes are engaged, replace the brush access door.
6. Lift up on the wipers first to close the side door and depress the latch until the door is secured.

NOTE: If the brushes are not fully engaged with the drivers the brushes will be damaged. Do not force the access door back on. This usually indicates improper brush installation.

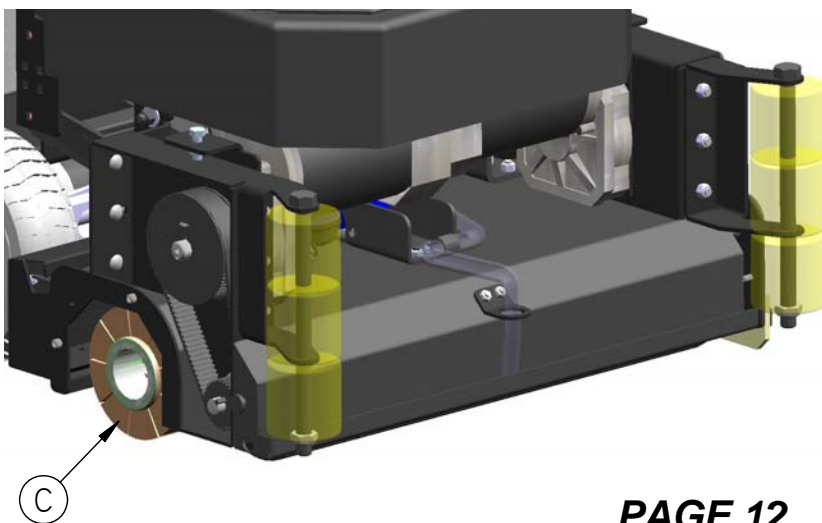

7. Brush driver shown misaligned. *(SEE BELOW)*

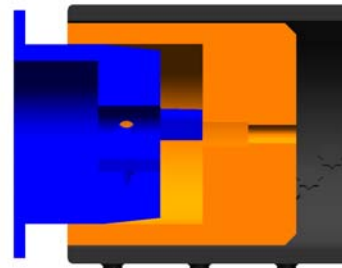

Old Style Driver

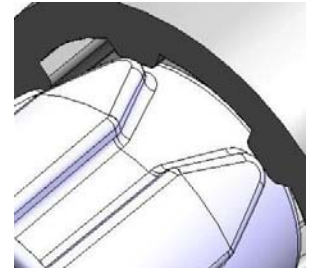

New Style Driver

8. Brush driver shown properly aligned. *(SEE BELOW)*

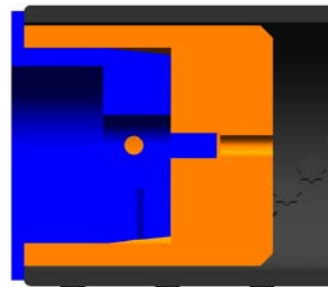

Old Style Driver

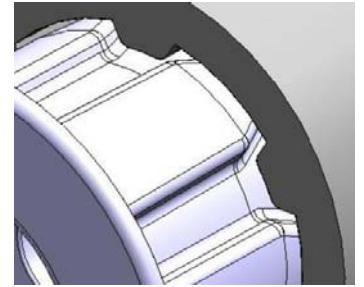

New Style Driver

9. To adjust the tension of the belts turn adjustment screw "D" clock-wise to tighten, counter-clockwise to loosen. *(SEE BELOW)*
10. To adjust the height of the wipers loosen the 3 screws "E" and slide wiper blades up or down in the slots. *(SEE BELOW)*

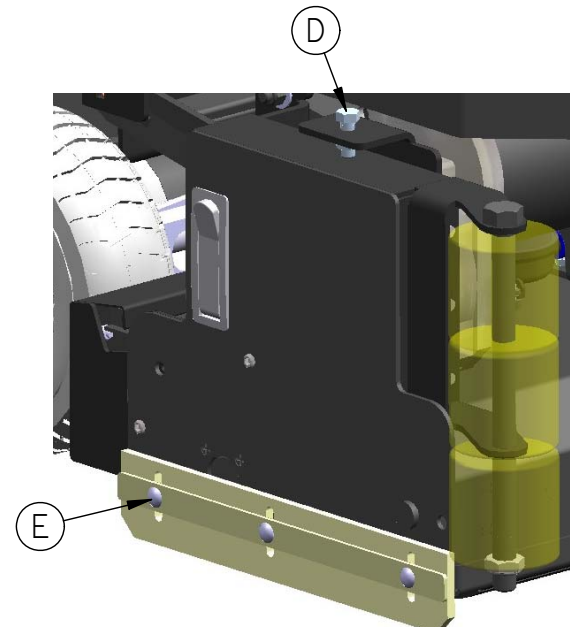

OPERATION

PRE-CLEANING CHECK LIST

Read and understand the safety section on pages 5 and 6 before operating the machine.

1. Check battery condition gauge on the control panel. Make sure batteries are fully charged before using.
2. Check the condition of the pads or brushes.
3. Check the condition of the squeegee blades.
4. Transport the machine to the filling station. Raise the scrubhead and squeegee when transporting.
5. Turn machine off.
6. Fill the tank with up to 17 gallons of clean water either at front fill port "A" or rear fill port "B". Access rear fill port by raising the recovery tank lid. **(SEE BELOW)**

*The clear tube "C" at the rear of the machine indicates the amount of water in the tank. **(SEE BELOW)**

8. Add "approved" cleaning chemical. Use the proper dilution ratio indicated on the bottle. Call if unsure.

Note: Use only non-flammable commercial cleaning chemicals. Your authorized distributor can assist you in selecting a proper chemical.

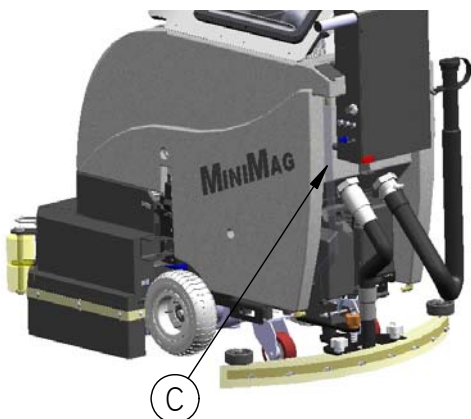
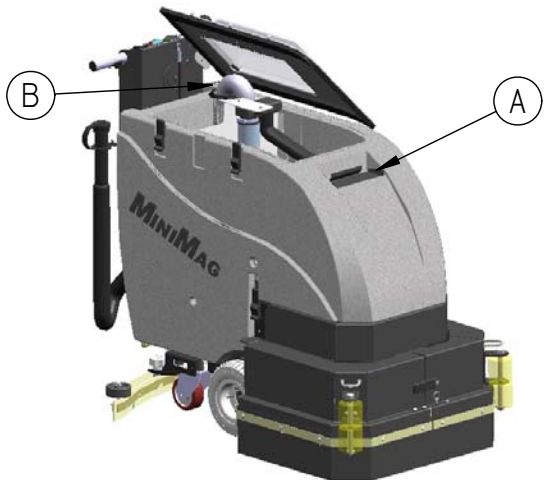

OPERATING HINTS

1. Observe the amount of solution the machine is dispensing on the floor and adjust to the desired flow. To increase the solution flow rate, rotate the solution control knob counter-clockwise. To shut the solution off completely, just release the drive button.
2. Keep an eye on the clear vacuum cover to make sure there is not any foamy buildup in the recovery tank. If excess foam begins to develop, pour a recommended foam control solution into the recovery tank. Foam is usually an indication of excessive soap.
3. Always operate at lower speeds when scrubbing around walls and objects. You should reduce the speed, to maintain control when turning.
4. If squeegee starts to streak, raise and wipe the blades with a clean cloth. If the problem continues, check the blades for wear or damage, and rotate if needed. You may need to presweep before scrubbing.
5. Change or turn over pads when dirty. Rotate the scrub brushes every week.
6. Stay clear of objects protruding from the floor, such as sockets, grates, for they will damage the pads and squeegee blades.
7. During brief stops you do not have to turn anything off, the brushes and solution will automatically stop when the drive button is released.
8. Always keep an eye on your gauges. They let you know the status of a particular system at a glance. If your battery gauge is reading low, you must stop immediately, and recharge. Running the batteries dead, will result in damage to the batteries.
9. When you run out of solution, raise the brushes, and continue to vacuum the remaining water until it is consumed. The solution sight hose is used to indicate the level of detergent remaining in the tank.
10. When you are ready to stop, pick up the brushes, turn off the solution switch, pick up the squeegee, and drive the machine back to the charging area. Be sure to drain both tanks before storing the machine.

ONE PASS SCRUBBING

BRUSH DRIVE MACHINES - (SEE BELOW)

1. Turn on machine power switch "A", make sure the "PAD ASSIST" adjustment knob "B" is at a low setting.
2. Lower squeegee by rotating the squeegee lift lever "C" all the way to the right (vac motor will turn on automatically.)
3. Lower scrub head to the floor, use the top half (+) of the brush switch "D".
4. Turn on the solution switch "E".
5. Begin scrubbing by depressing the green control button "F" on the handle bar. Adjust the "PAD ASSIST" adjustment knob "B" to the desired setting.
6. Once the machine begins to move, check the down pressure gauge "G". Start scrubbing at the middle. Do not scrub in the red, or the circuit breaker will blow.
7. To stop the machine, let go of the green control button "F".

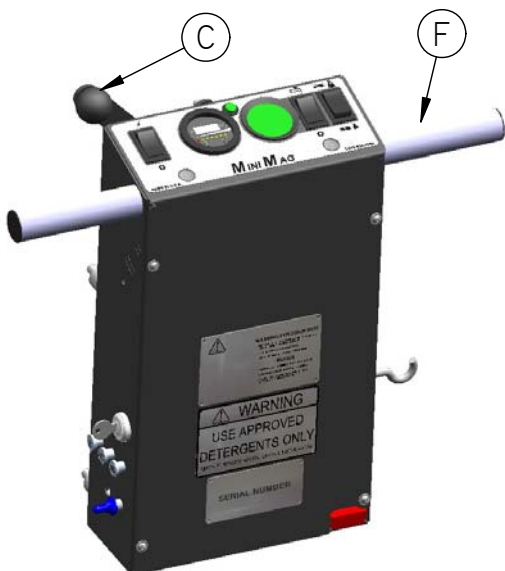

SCRUB ONLY

BRUSH DRIVE MACHINES - (SEE BELOW)

1. Turn on machine power switch "A", make sure the "PAD ASSIST" adjustment knob "B" is at a low setting.
2. Lower scrub head to the floor, use the top half of the brush switch "D".
4. Turn on the solution switch "E".
5. Begin scrubbing by depressing the green control button "F" on the handle bar. Adjust the "PAD ASSIST" adjustment knob "B" to the desired setting.
6. Once the machine begins to move, check the down pressure gauge "G". Start scrubbing at the middle. Do not scrub in the red, or the circuit breaker will blow.
7. To stop the machine, let go of the green control button "F".

VACUUM ONLY

BRUSH DRIVE MACHINES - (SEE BELOW)

1. Turn on machine power switch "A".
2. Lower squeegee by rotating the squeegee lift lever "C" all the way to the right (vac motor will turn on automatically.)
3. Push machine forward over solution.

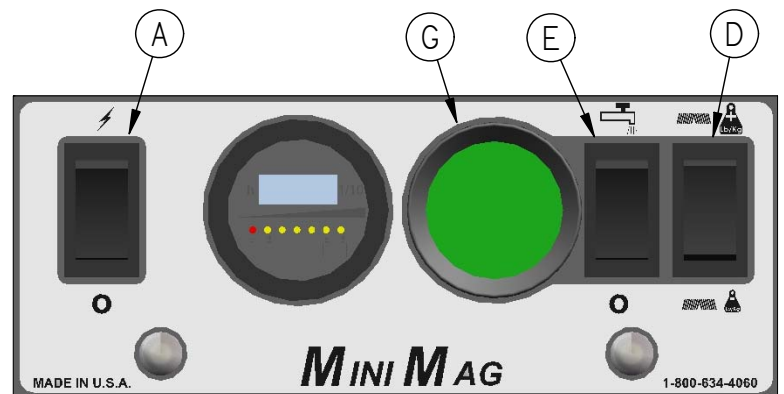

ONE PASS SCRUBBING

TRACTION DRIVE MACHINES - (SEE BELOW)

1. Turn on machine power switch "A", make sure the speed control knob "B" is at it's lowest setting.
2. Lower squeegee by rotating the squeegee lift lever "C" all the way to the right (vac motor will turn on automatically.)
3. Lower scrub head to the floor, use the top half (+) of the brush switch "D".
4. Turn the solution flow adjustment knob "E" to regulate the amount of solution flow.
5. Begin scrubbing by depressing one of the green control buttons "D" on the handle bar. Adjust the speed control knob "B" to the desired setting.
6. Once the machine begins to move, check the down pressure on the LCD screen "F". To adjust the down pressure, push toggle switch "G" forward to increase pressure backward to decrease pressure. Start scrubbing at the #1 or #2 marks. Do not use the #4 or #5 marks without management's approval.
7. To operate the machine in reverse, simply pull the forward/reverse switch "H" back towards the handle bar. The reverse speed is set to approximately 50% of the forward speed.
8. To stop the machine, let go of the green control button "D".

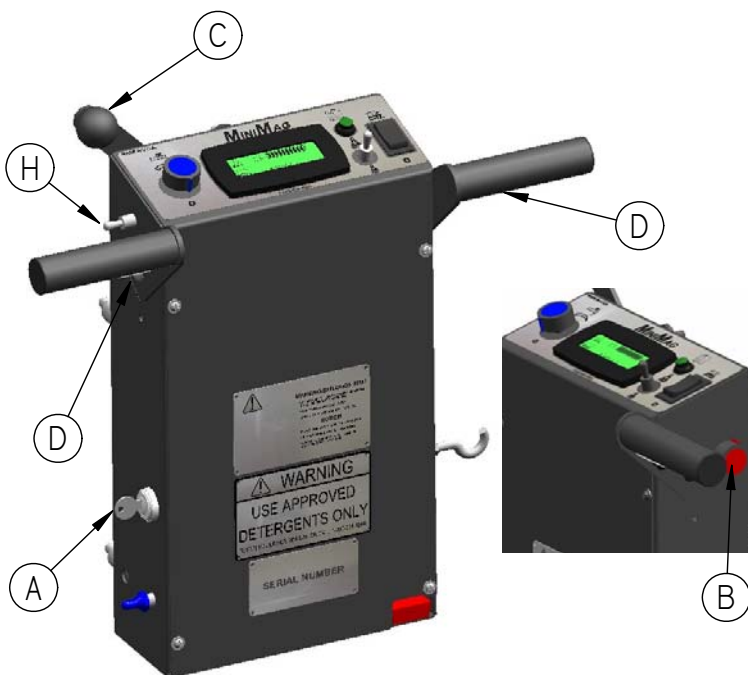

SCRUB ONLY

TRACTION DRIVE MACHINES - (SEE BELOW)

1. Turn on machine power switch "A" make sure the speed control knob "B" is at it's lowest setting.
2. Lower scrub head to the floor, use the top half of the brush switch "D".
4. Turn the solution flow adjustment knob "E" to regulate the amount of solution flow.
5. Begin scrubbing by depressing one of the green control buttons "D" on the handle bar. Adjust the speed control knob "B" to the desired setting.
6. Once the machine begins to move, check the down pressure on the LCD screen "F". To adjust the down pressure, push toggle switch "G" forward to increase pressure backward to decrease pressure. Start scrubbing at the #1 or #2 marks. Do not use the #4 or #5 marks without management's approval.
7. To operate the machine in reverse, simply pull the forward/reverse switch "H" back towards the handle bar. The reverse speed is set to approximately 50% of the forward speed.
8. To stop the machine, let go of the green control button "D".

VACUUM ONLY

TRACTION DRIVE MACHINES - (SEE BELOW)

1. Turn on machine power switch "A", make sure the speed control knob "B" is at it's lowest setting.
2. Lower squeegee by rotating the squeegee lift lever "C" all the way to the right (vac motor will turn on automatically.)
3. Begin vacuuming by depressing one of the green control buttons "D" on the handle bar.

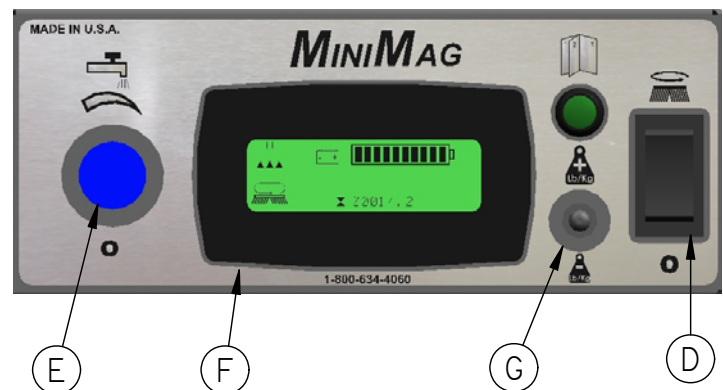

ADJUST SOLUTION FLOW

1. Turn solution valve adjustment knob "A" counter-clockwise to increase solution flow, clockwise to decrease solution flow. (SEE BELOW)

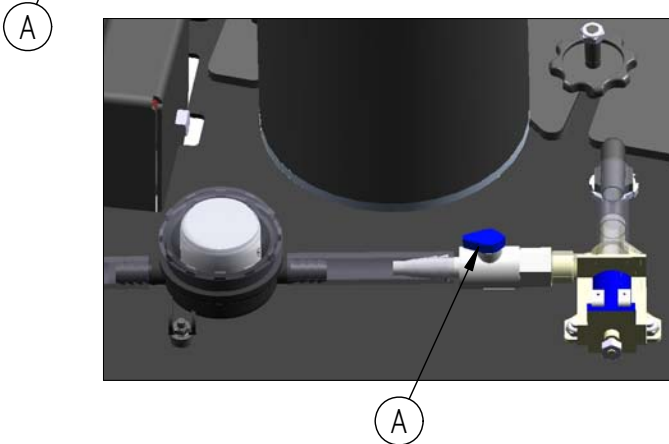

DRAINING SOLUTION TANK

To drain unwanted cleaning solution from the solution tank, perform the following steps.
(SEE BELOW)

1. Pull the clear sight tube/drain hose "A" off barbed fitting.
2. Rinse out tank and solution flow system with clean water.

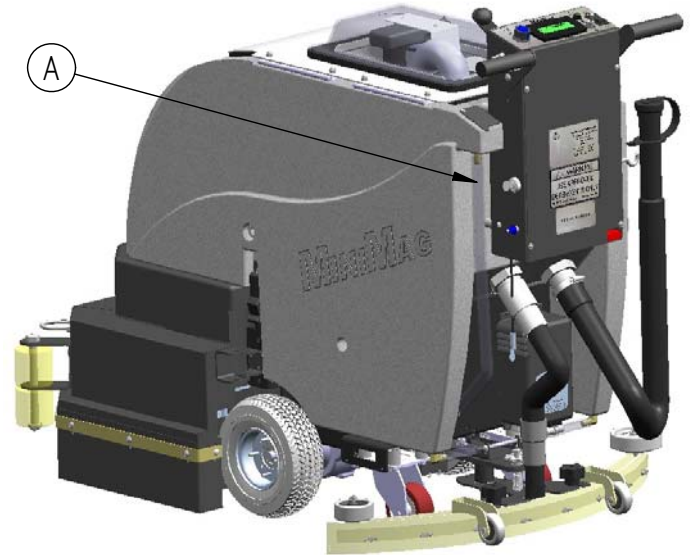

ADJUST CURTAINS/WIPERS

1. For Jaw curtains release latch "A" and remove pin "B" on front of jaws to open jaws. (SEE BELOW.)
2. Loosen curtain band screws "C".
3. To adjust curtain to the desired height just slide the curtain up or down in the slots and tighten screws.
4. Close jaws, reconnect latch and reinsert pin.

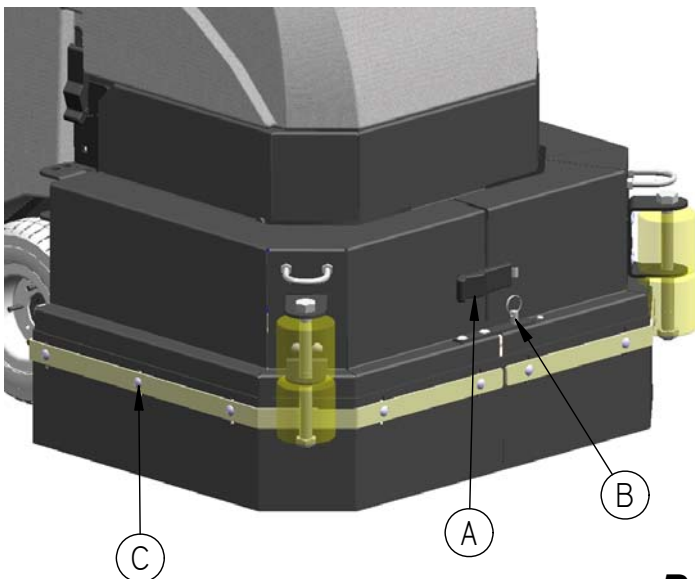

DRAINING RECOVERY TANK

Always empty recovery tank when refilling the solution tank. You can refill the solution tank while the recovery tank is draining. To drain the recovery tank, remove drain hose (A) from hook at rear of tank and unscrew cap. (SEE BELOW)

NOTE: LEAVE RECOVERY LID OPEN WHEN DRAINING TANK!

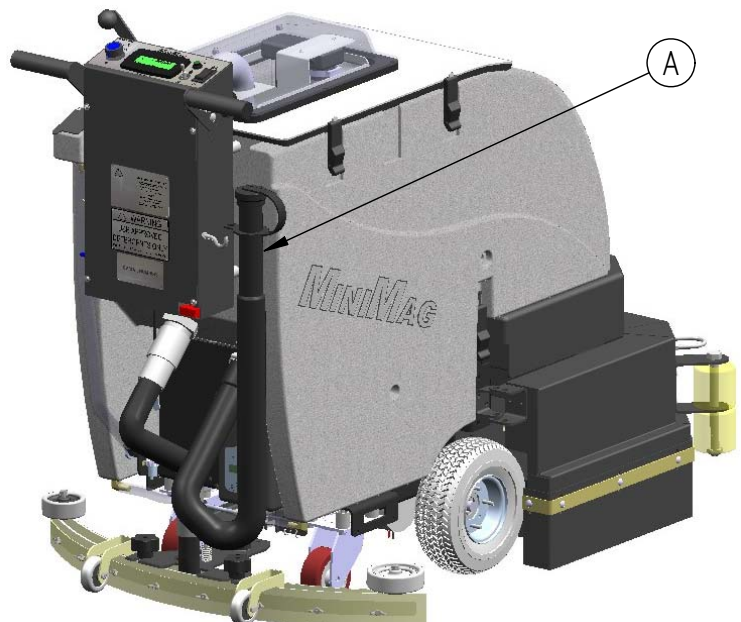

OPEN RECOVERY LID

1. Release both latches "A" on recovery tank lid. *(SEE BELOW)*
2. Rotate lid fully open.

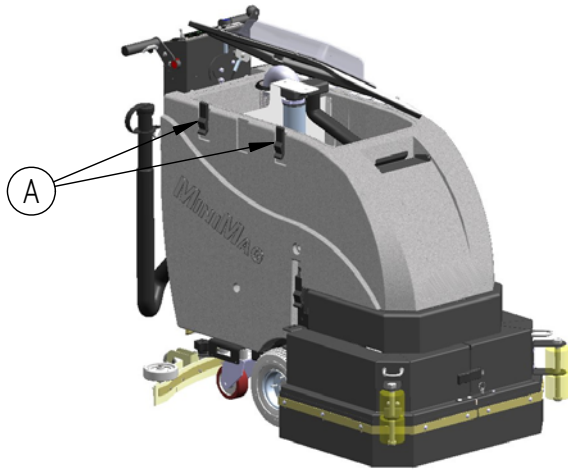

FLUSH RECOVERY TANK

1. Rinse the recovery tank after every use. This will prevent heavy buildup on the bottom of the tank, foul odors, and clogging of the drain hose. *(SEE BELOW)*



3. After rinsing, reattach drain hose "B" on hook. *(SEE BELOW)*

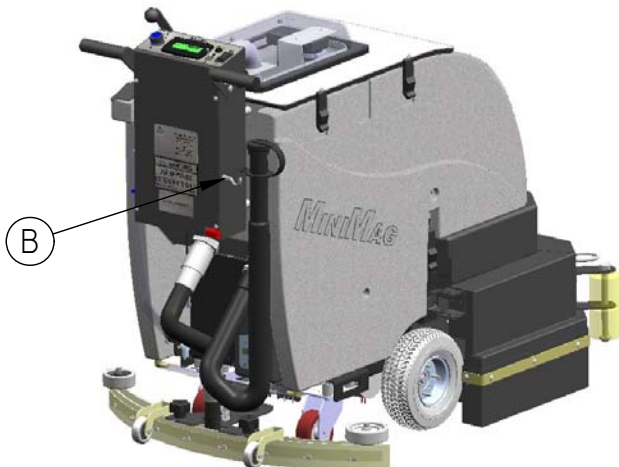

CLEAN "DRAIN SAVER"

WITH RECOVERY LID OPEN & TANK FULLY DRAINED

1. Remove 2" squeegee intake hose "A" from "Drain Saver" strainer "B". *(SEE BELOW)*
2. Remove stainless screen, dispose of debris.
3. Rinse screen with fresh water from the outside to the inside holding screen upside down. This will allow for better cleaning.
4. Replace the screen into the bracket.
5. Replace 2" squeegee intake hose.

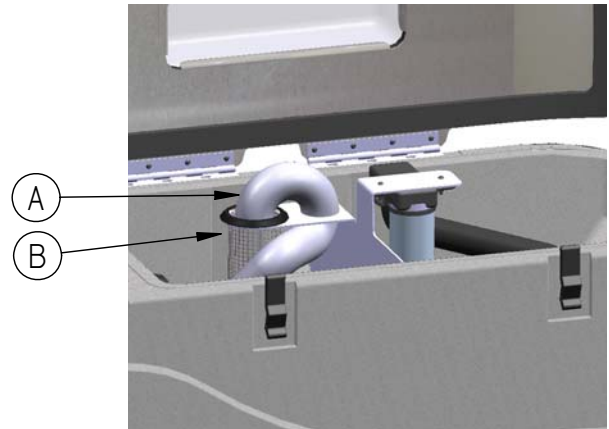

CLEAN VAC SCREEN

WITH RECOVERY LID OPEN & TANK FULLY DRAINED

1. Remove vac screen retaining clip "A". *(SEE BELOW)*
2. Pull vac screen and float ball assembly (B) off the vac box.
3. Rinse with hot water.
4. Dry thoroughly.
5. Replace vac screen onto box.
6. Replace and tighten retaining clip.

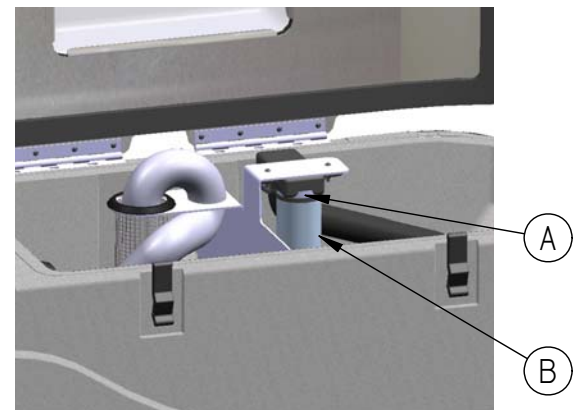

TIP TANK

1. Fully drain solution tank.
2. Fully drain recovery tank.
3. Remove squeegee.
4. Unlatch tank latch "A" on each side of machine. *(SEE BELOW)*
5. Open Jaws. *(SEE BELOW)*
6. Tip tank back carefully until supported by strap. (strap not shown) *(SEE BELOW)*

* **CAUTION:** Casters need to be swiveled back (B) as shown, otherwise machine will tip.

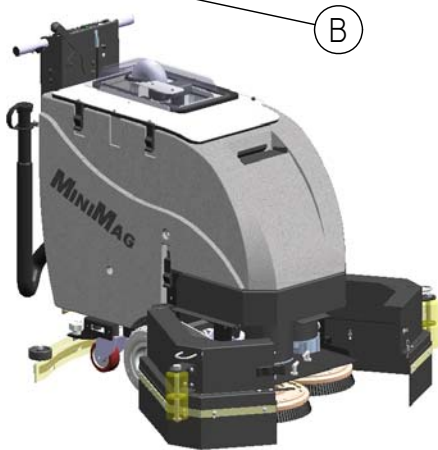

SQUEEGEE UP

1. To raise the squeegee off the floor rotate squeegee lift lever "A" counter-clock-wise all the way to the left. *(SEE BELOW)*



SQUEEGEE DOWN

1. To lower the squeegee to the floor rotate squeegee lift lever "B" clockwise all the way to the right. Vac motor will turn on automatically. Use with remote vac wand. *(SEE BELOW)*



DECK HEIGHT ADJUSTMENT

1. To adjust deck height for brush clearance, loosen jam nut on adjustment bolt "A", turn adjustment bolt clock-wise to raise deck, counter-clockwise to lower deck. Retighten jam nut. (SEE BELOW)

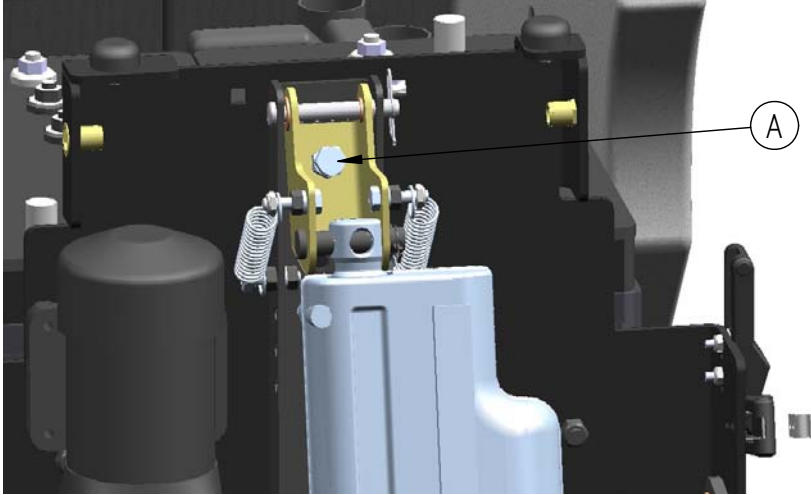

VAC MOTOR

(SEE BELOW)

1. The machine is equipped with a 24 volt, 3/4 hp, vac motor "A".
2. If foam or water gets past the recovery tank's vac screen/ball system the "UNLOADER VALVE" "B" will drain it from the "VAC BOX" "C".
3. The vac motor has an "optional" "FOAM MUFLER" "D" available for quiet machine operation.

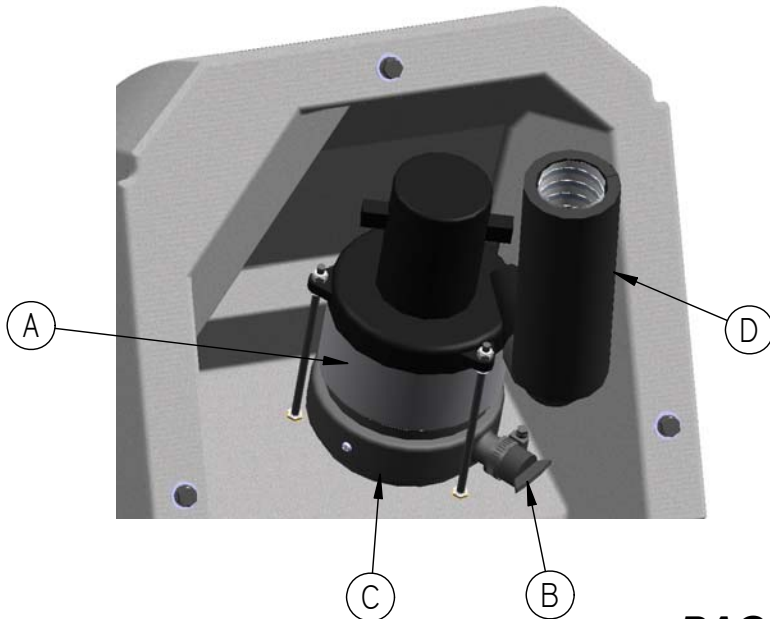

SOLUTION FILTER

1. The solution system has a "INLINE FILTER" "A" to filter out cleaning solution prior to scrubbing. (SEE BELOW)

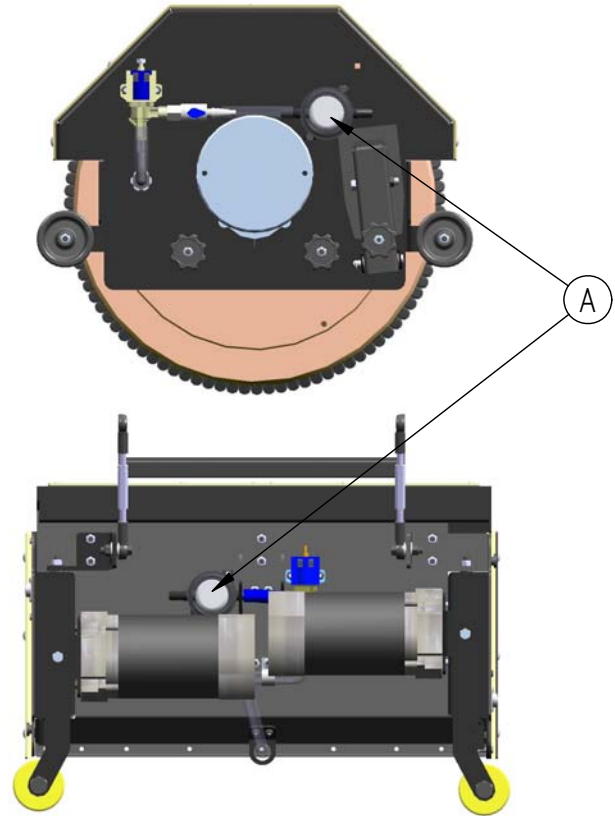

CLEANING SOLUTION FILTER

(SEE BELOW)

1. To clean the "SOLUTION FILTER" Unscrew the clear cap "A" from housing "B" and remove the "STAINLESS STEEL" screen "C".
2. Rinse any debris from the screen with clean water.
3. Reinstall screen and screw cap back on tightly.

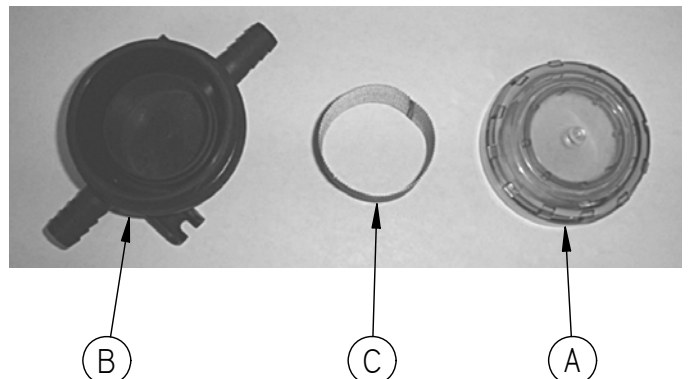

EXTERNAL BATTERY CHARGING (OPTIONAL)

CAUTION:The following instructions are intended for the 24v charger supplied with the machine.
Do not use any other charger with this machine.

CHARGER SPECIFICATIONS

- * OUTPUT VOLTAGE OF 24 VOLTS.
- * OUTPUT CURRENT OF 18 AMPS MAX (OPTIONAL).
- * INPUT VOLTAGE OF 110 VOLTS/60 HZ.
- * AUTOMATIC SHUT OFF CIRCUIT.
- * MADE FOR DEEP CYCLE BATTERIES.

DANGER: Always charge batteries in a well ventilated area. Batteries emit hydrogen gas. Explosion or fire can result. Keep sparks and flame away. Shield eyes when servicing batteries and avoid contact with battery acid.

1. Transport machine to a well ventilated area for charging.
2. Turn the machine off.
3. **CAUTION ALWAYS WEAR EYE PROTECTION WHEN BATTERIES ARE EXPOSED.**
4. Check the water level through "pro-eye" window in each battery. (**SEE TOP PICTURE.**) Do not charge the machine unless the water is slightly higher than the plates. If needed, add enough *distilled* water to just slightly cover the plates. Be careful not to over fill. Batteries can overflow during charging. Replace caps before charging.
5. With the red 50 charger plug connected to the machine "**FIRST**" (**SEE MIDDLE PICTURE.**) plug the charger power cord into a grounded 110 volt standard wall outlet "**SECOND**". (**SEE BOTTOM PICTURE.**)
6. The charger will automatically begin charging, and automatically shut off when fully charged. (**check gauge**)
7. After the charger has turned off, unplug the charger from the wall outlet "**FIRST**"; then unplug the red 50 charger plug from the machine "**SECOND**".
8. Recheck the cell level after charging. If needed, add distilled water up to the correct level. Be certain to replace the caps securely and to wipe off the top of the batteries with a clean cloth.

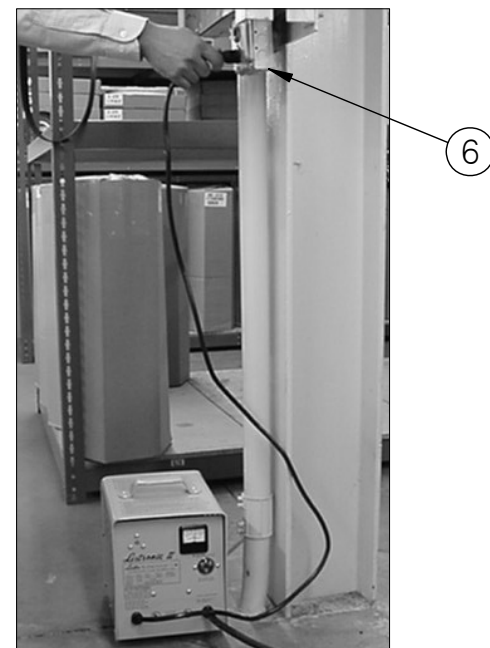
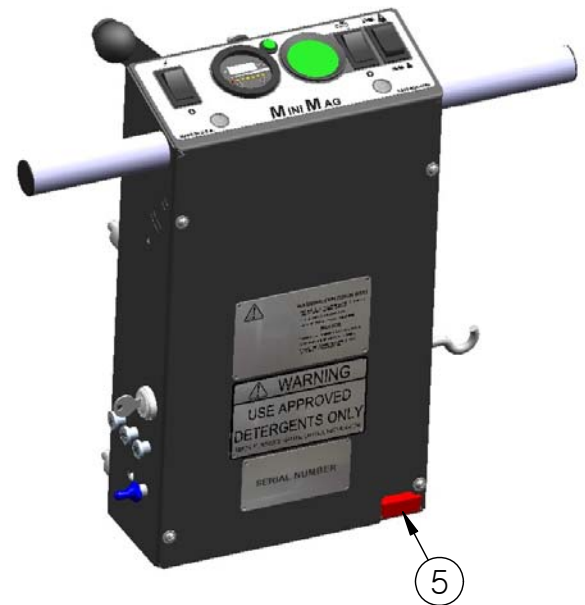

ON-BOARD CHARGER

TECHNICAL FEATURES OF THE POWERCAT CBHF1-SM CHARGER

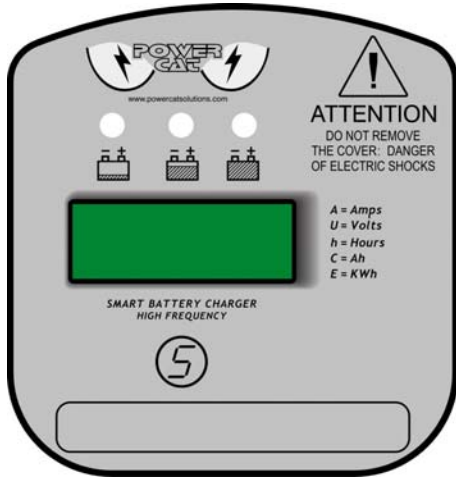

The innovative characteristics of the **POWERCAT** CBHF1-SM battery charger are the following:

1. Advanced Mosfet technology with high frequency.
 2. Charging process fully controlled by microprocessor.
 3. Visualization on an LED display of the charging current, battery voltage, charging time, electric charge supplied in Ah's and electric energy supplied in KWh's.
 4. Possibility to change the charging curve by means of microswitches (DIP-switches), from pre-programmed curves for PowerCat lead-acid, Gel or agm batteries.
 5. Soft-start charging process.
 6. Storage of the data of the charge cycle after completion and automatic reset upon connection of a new battery.
 7. Protection against polarity inversions, short-circuits, over-voltages or anomalies by means of an output relay.
8. Battery to battery charger connection without sparks on the output terminals with obvious advantages for the safety, thanks to the recognition of the battery voltage downstream the normally opened output relay.
 9. Alphanumeric signals of possible anomalies.
 10. Insensitive charge parameters in case of $\pm 10\%$ network voltage
 11. Efficiency > 85%.
 12. Output ripple at maximum charge lower than 100mV.
 13. Start of the charge cycle with batteries as low as 2V.
 14. Thermal protection against over heating.
 15. An auxiliary relay that prevents the machine from starting while the battery charger is operating for additional safety.

DIP switches located here below sticker.

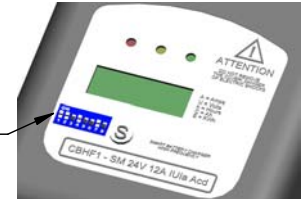

OPERATING PRINCIPLE

When the charger is plugged in the display will show details of the current charger programming; these parameters depend on internal dipswitch configuration. The following details are shown:

- 1 - "SPE"
- 2 - Version of software installed in the charger.
- 3 - Battery voltage
- 4 - Charging current
- 5 - Number of charging curve selected (see explanation at bottom of following page)
- 6 - The message "Acd" if programmed charging curve is for POWERCAT wet Lead-Acid batteries or "GEL" if programmed charging curve is suitable for sealed batteries.

After this, the charger checks the battery voltage and to decide whether to start the charging process. If the battery is not connected to the battery charger, the message 'bat' will be displayed. The same message is displayed also in case of negative result of the testing (for example, reversed polarity or battery having a wrong voltage). If the result of the testing is positive, the value of the battery voltage is displayed for about 5 seconds, with output relay open. After 5 seconds the charging of the battery can start. The output relay closes and the current of the first phase rises slowly till it reaches the nominal value programmed.

If the user disconnects the battery from the battery charger during the charging process, after a few seconds the battery charger will re-initialize and prepare to start a new charging process.

The display always shows the charging current of the battery. The battery voltage, the time since the beginning of the charge, the charge yielded in Ah's and the energy consumed in KWh can be seen by pressing the button "S".

The progress of the charging process is shown by three LED's: red, yellow and green.

The green LED indicates the end of the charging process for wet lead-acid batteries and the float charging stage for sealed batteries.

ON-BOARD CHARGER

ERROR CODES

- If the maximum voltage admissible for a specific battery is reached (value given by the manufacturer) the error message '**E01**' is displayed, and the process is terminated.
- By using an internal thermostat, the charging can be interrupted in case of excessive battery charger over-temperature. In this case the error message '**E02**' is displayed.
- The charge cycle will be interrupted and the error message '**E03**' will be displayed if the duration of the second charging phase exceeds normal limits. This usually indicates a sulfated (damaged) battery. Sometimes, a second charge attempt can be successful in recharging the battery pack.
- The display of the message '**Sct**' indicates safety timer operation.
- The message '**Srt**' will be displayed in case of internal short circuit.

DIP SWITCH CONFIGURATION

Through the set of 8 dip switches it is possible to change the charging curve for POWERCAT wet lead-acid or gel batteries. The set of 8 dipswitch is easy to find (is located under the front label of the charger, lifting the corner on the bottom-left) without opening the charger.

DIP SWITCH SETTINGS FOR WET LEAD-ACID BATTERIES

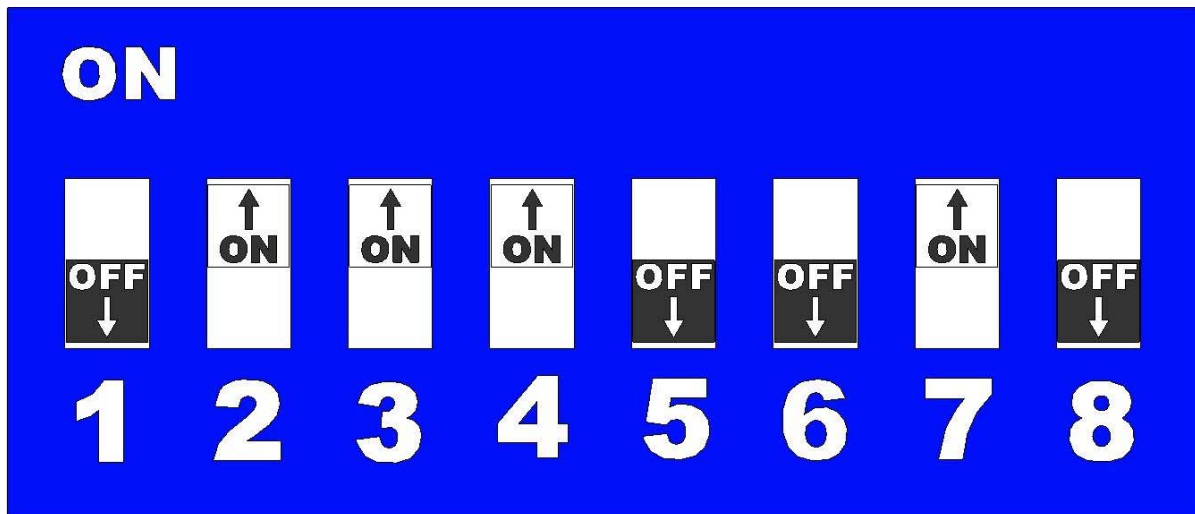

DIP SWITCH SETTINGS FOR SEALED LEAD-ACID AND GEL BATTERIES

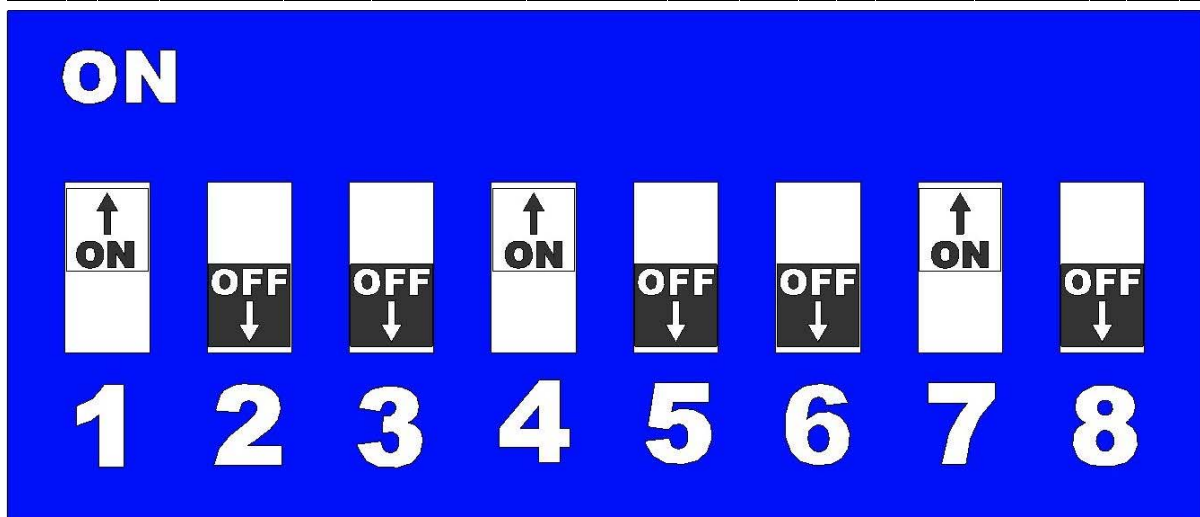

BATTERY CHARGER

OPERATING MANUAL

GENERAL INFORMATION AND WARNING

- Electronic automatic battery charger with microprocessor suitable for any battery type.
- Fully automatic charging cycle with electronic setting; protected against overload, short-circuit at clamps and reversed polarity.
- Never disconnect the battery while charging: this could cause sparks.
- Never use the equipment in the rain, in areas used for washing and in damp areas.
- Before starting to charge, make sure the voltage of the equipment suits the voltage of the battery and that the selected charging curve (for lead-acid free batteries and airtight gel batteries) is correct for the type of battery to be charged. In addition, make sure the rated input voltage of the charger suits the available supply voltage and the system is equipped with grounding.
- If necessary, replace the fuse with another of the same type and value as indicated on the rating plate.
- Pay attention to any remarks of the battery manufacturer.

For lead-acid batteries with liquid electrolyte:

- Control the water level after each charging process.
- Refill with distilled water only.
- Caution! The gases generated during charging are explosive. Do not smoke in the vicinity of the batteries. When working with cables and electrical equipment, avoid open flame and sparks.
- Attention: Use protective glasses and gloves during battery maintenance. Battery acid causes injuries. In case of contact with battery acid, wash the affected parts with a lot of fresh water and consult a doctor if necessary.

CONTROLS (see figure behind the cover)

1. Three-digit display + symbol (1), to view A = the charging current, U = the battery voltage, h = the charging time, C = the charging ampere-hours [AH], E = the energy used [KWh].
2. Button for the Selection of the display mode (2): A, U, h, C, E. After about 10 seconds the display returns to the visualization of the charging current.
3. Red control indicator (3): when it is on, the charging cycle has started.
4. Yellow control indicator (4): when it is on, the final phase of the charging cycle has started.
5. Green control indicator (5): when it is on, the charging cycle has finished.

OPERATION

- Plug the cord into the socket.
- Connect the battery, checking the polarity.
- Now, the battery charger's display will show a sequence of details on the charger's internal programming: after the name "SPE", it will show the software release installed in the equipment, then, in sequence, the following parameters: battery voltage, charging current, charging curve number, and finally the words "GEL" or "Acd" depending on the set up charging curve being suitable for airtight gel batteries or lead-acid batteries. **Make sure the type of batteries to be charged (gel or lead-acid batteries) matches the displayed details ("GEL" or "Acd", respectively). If it doesn't, contact our dealer.** Now, a test is run on the battery voltage to decide if the charging process should be started or not. If the battery is not connected to the battery charger, the display will show the word "bat". The word will stay on, even if the test is failed (for instance, reversed polarities or incorrect battery connection). If the test is passed, the display will show the battery voltage for approximately 5 seconds and the battery will begin to

BATTERY CHARGER

be charged. The charging cycle progress will be shown by red (3), yellow (4), and green (5) LED indicators.

At the end of the charge, when the green indicator (5) is on, unplug the cord from the socket and operate the machine.

PROBLEMS	SOLUTIONS AND CHECKS
The battery charger does not switch on.	Check that the plug is connected to the supply mains and that the fuse is efficient.
The charging cycle does not start and the message "bat" is displayed.	Check the connection to the battery and polarity.
The yellow indicator (4) will not light up even 15 hours from the starting of the charging cycle, and the display shows E03 .	Check the battery for possible faulty components.
The message E01 is displayed.	This means that the maximum voltage admissible by the battery has been exceeded. The charging is interrupted.
If the battery charger is provided with a safety thermostat and the message E02 is displayed.	This means that the maximum temperature has been exceeded. The charging is interrupted.
The message E03 is displayed.	This means that the maximum time for the charging phase has been exceeded. The charging is interrupted.
The message Sct is displayed.	This means that the total safety timer has interrupted the charging.
The message Srt is displayed.	This signals a possible internal short circuit.

Maintenance

Daily Maintenance

1. Remove and clean pads or brushes. Never use soiled pads when cleaning. Replace pads when they become packed with residue.
2. Remove and clean debris from the float shut-off screen and drain saver located inside the recovery tank.
3. Drain and rinse tanks thoroughly
4. Inspect vacuum hose for any objects obstructing the air flow.
5. Raise squeegee and wiper blades with a clean cloth. Store squeegee in the raised position to prevent damage or setting of the blades.
6. Wipe down machine if needed. Use a nonabrasive, non solvent cleaner, or a clean damp cloth.
7. Recharge the batteries if needed.

Weekly Maintenance

1. Check battery water level in each cell of the batteries, and fill as needed. Always use distilled water to refill batteries. Batteries should be filled approximately 3/4" to 1" above the plates. Overfilling will cause the batteries to leak during charging. The charging process creates gas bubbles inside the battery, which effectively increases the volume of the electrolyte.
2. Clean battery tops to prevent corrosion.
3. Rotate brushes. Rotate the left to the right and right to left. On cylindrical models from front to back, or end to end if using different materials.
4. Drain and rinse tanks thoroughly. To thoroughly flush out any solution chemicals in solution line and valves, refill solution tank with a few gallons of warm clean water and run machine until tank is empty.

Monthly Maintenance

1. Check scrub head and squeegee lifting cables for wear and spring tension.
2. Check machine for water leaks and loose nuts and bolts.
3. Check to see if battery cables are tightened (Tighten if needed)
4. Check parking brake

Yearly Maintenance

1. Call your local dealer for yearly maintenance

Storing Machine

1. Be sure to flush the tanks out completely. To thoroughly flush out any solution chemicals in solution line and valves, refill solution tank with a few gallons of warm clean water and run machine until tank is empty.
2. Open the recovery tank lid to promote air circulation.
3. Raise brushes and squeegee.

Checking Battery Specific Gravity

Use a hydrometer to check the battery specific gravity.

Checking Gravity

A. Hydrometer

B. Battery

Note: do not take readings immediately after adding distilled water, if water and acid are not thoroughly mixed, the reading may not be accurate.

Check the hydrometer against this chart

SPECIFIC GRAVITY @ 80° F (27°C)	BATTERY CONDITION
1.265	100% CHARGED
1.225	75% CHARGED
1.190	50% CHARGED
1.155	25% CHARGED
1.120	DISCHARGED

Note: if the readings are taken when the battery electrolyte is any temperature other than 80° F (27° C), the reading must be temperature corrected.

To find the corrected specific gravity reading when the temperature of the battery electrolyte is other than 80° F (27° C): add (+) to the specific gravity reading 0.004 (4 points), for each 10° F (6° C) above 80° (27° C). subtract (-) from the specific reading 0.004 (4 points), for each 10° F (6° C) below 80° F (27° C).

PREVENTATIVE MAINTENANCE RECORDS

CUSTOMER INFORMATION						
CUSTOMER						
ADDRESS						
CITY			STATE		ZIP CODE	
MACHINE INFORMATION						
MODEL #			SERIAL #			
WORK ORDER#			HOUR METER:			
BATTERY CONDITION						
	Cell #1	Cell #2	Cell #3	Cell #4	Cell #5	Cell #6
Battery # 1 Hydrometer						
Battery # 1 Water Condition						
Battery # 2 Hydrometer						
Battery # 2 Water condition						
Battery # 3 Hydrometer						
Battery # 3 Water Condition						
Battery # 4 Hydrometer						
Battery # 4 Water condition						
Clean Battery Tops. Check Battery Cable and Terminal Condition						
NOTES:						
BRUSH CONDITION						
Scrub Brush Fiber Length		Rotated Brushes				
Brush Drive Sockets	Good	Worn	Needs Replacement			
Drive Hubs	Good	Worn	Needs Replacement			
CHECK OPERATION AND CONDITION OF:						
	IN SPEC	REPAIR	PROBLEM			
Main Power Switch or Key Switch						
Handle Bar Switches						
Speed Potentiometer						
Reverse Switch						
LCD Display						
Page Switch						
Brush Pressure Switch						
Brush Pressure Managers Lock Out						
Reverse Switch						
Brush Switch						
Brush Deck Lift System						
Brush Motor						
Brush Drive Belt						
Solution Potentiometer						
Solution Solenoid						
Vacuum Switch						
Vacuum Motor Performance						
Vacuum Filter						
Recovery Drain Hose & Plug						
Squeegee Lift System						
Squeegee Adjustment						

continued on next page

PREVENTATIVE MAINTENANCE RECORDS

CHECK OPERATION AND CONDITION OF:	IN SPEC	REPAIR	PROBLEM
Spray Jet Switch			
Spray Jet Pump, Hose & Nozzle			
Battery Charger Connectors			
Battery Charger			

CLEAN AND/OR LUBRICATE	IN SPEC	REPAIR	PROBLEM
Solution Filter			
Squeegee Pivot Points & Knobs			
Scrub Deck Linkage			
Caster grease fittings			
Squeegee Knob Threads			
Squeegee Pivot Points			
Brush Head Pivot Points			

VISUALLY INSPECT:	IN SPEC	REPAIR	PROBLEM
Solution Tank Condition			
Recovery Tank & Lid Condition			
Drain Saver			
Vacuum Float			
Vacuum Motor Brushes			
Vacuum Hoses			
Vacuum Filter			
Solution Hoses			
Squeegee Tool and Throat			
Squeegee Blades			
Blade retainers & Hardware			
Squeegee Wheels			
Brush Skirts			
Brush Motor Brushes			
Brush or Pad Driver Condition			
Drive Wheel Condition			
Caster Condition			

COMMENTS

Technician's Name _____

Technician's Signature _____ Date _____

Customer's Name: _____

Customer's Signature _____ Date _____

LCD Screen Menu Displays

SCREEN # 1 (Operator)

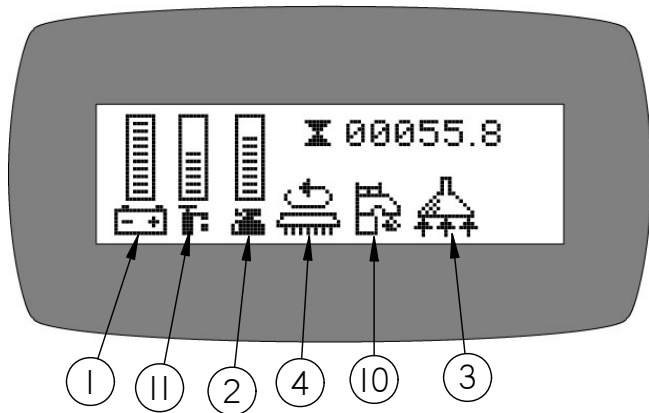

SCREEN #3 (Maintenance)

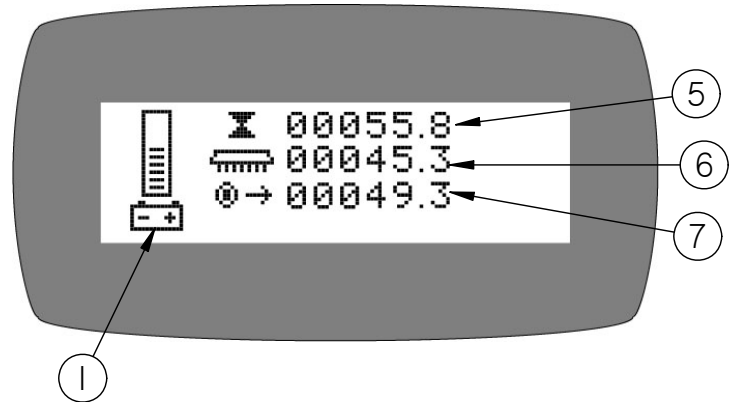

SCREEN W/ERROR CODE

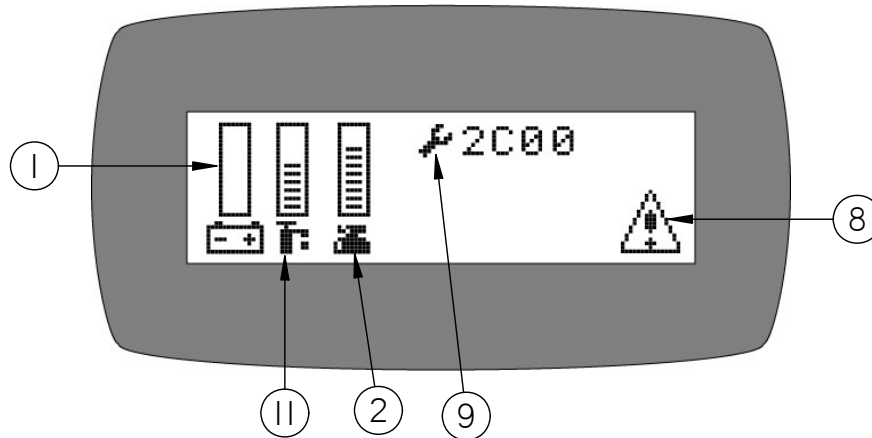

Use green menu selection button on control panel to change screens

1. **Battery level indicator** - Indicates the energy level remaining in the batteries. *(Shown on all menu displays)*
2. **Scrubdeck down pressure gauge** - Sets the down pressure on the brushes.
3. **Vacuum on** - Indicates the vacuum is "on".
4. **Scrub motors on** - Indicates the brush motors are "running".
5. **Key switch hour meter** - Tells you the total hours the machine has been on.
6. **Scrub brush hour meter** - Tells you the total hours the brush motors have been used.
7. **Transport hour meter** - Tells you the total hours the drive system has been used.
8. **Error warning symbol** - Indicates when there has been a diagnostic code error.
9. **Diagnostic code** - When the machine has detected an error it will display the warning symbol and a diagnostic code which tells you what's wrong.
10. **Water on** - Indicates the solution flow is "on"
11. **Solution level** - Indicates the gallons per minute (G.P.M) 0 - 1.0 .

(For common error codes and descriptions see pages 27 & 28.)

TROUBLESHOOTING CENTRAL COMMAND

NOTE: This machine is operated by a sophisticated electronic "**CONTROLLER**" that has many fail-safes within it. The controller self-analyzes problems and flashes a four-digit numeric code of what is wrong in the LCD window.

Most of these codes require a technician's attention. You should not attempt repairs you are uncomfortable with, especially if you are not used to working on electronics.

The complete list of codes is published in the simplified electronic troubleshooting manual, which is available to technical people. However, we have included the basic codes that you can usually resolve yourself.

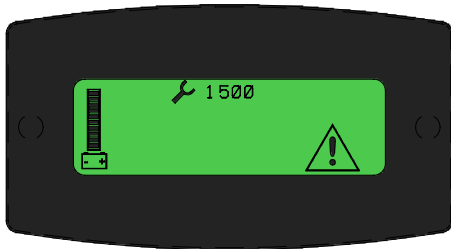

1. **1E03 AND 1E04 ERROR.** Check the small safety switch next to the red plug below the dashboard. This switch will turn off the traction drive and brushes as a safety feature while the charger is plugged in. The switch may be stuck, or the plug twisted at an angle, engaging the switch. This code will also flash if the wiring becomes very wet. In this case, either wait until the wiring dries out, or call a technician.



2. **7601 AND 7602 ERROR.** Pads or brushes current over load. This can occur when the pads/brushes hit a bump in the floor. To restart the pads, turn off the key and turn it on again. To avoid this error, either slow down on bumpy parts of the floor, or reduce downpressure on the pads or brushes.

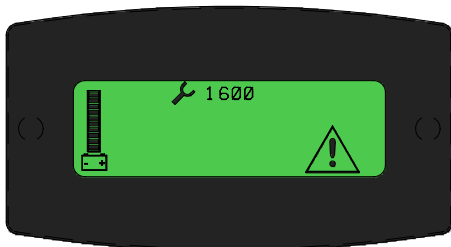

3. **1600 ERROR.** Voltage exceeds the maximum. Either the batteries are mis-wired, or the charger is still plugged into the machine.

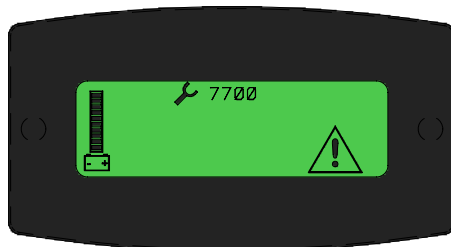

4. **7700, 7701, 7702, AND 7703 ERROR.** The vacuum motor has exceeded its authorized power limit. Turn off main power switch and turn on again to clear.

TROUBLESHOOTING CENTRAL COMMAND

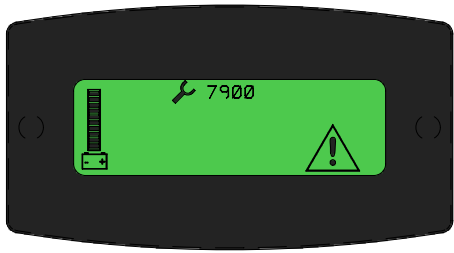

5. **7900 AND 7901 ERROR.** The emergency stop button is out.

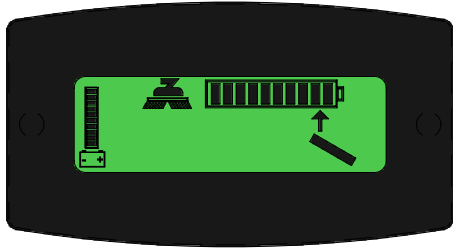

6. **HIGH THROTTLE ERROR.** You pressed the drive button before turning on the key. Turn off the key, release the drive button and try again.



7. **2C00 AND 2C01 ERROR.** Low voltage warning. Voltage has dropped down below the minimum required to operate the machine. If you wait a few minutes, the batteries may coast up a bit in voltage, allowing you to drive very slowly to the recharge station.



8. **7802 ERROR.** The traction motor was used to climb a ramp, and was running up the ramp for more than the 60 seconds allowed for this. Turn off the key, turn on again, and continue. You should not use this machine to climb ramps so steep and so long that this code comes up repeatedly, or you could overheat and damage the traction motor.

9. All other error codes. Turn off the main power switch and disconnect the positive battery cable from the batteries for more than one minute (*the time is needed to drain the controller's on-board capacitor*). Reconnect the cables being sure they are tight; too loose will burn the batteries. If you overtighten the cables you can damage the battery's lead terminal. Try again.

10. If the problem cannot be solved by any of these remedie's call your local dealer's service department.

TROUBLE SHOOTING

PROBLEM

CAUSE

SOLUTION

NO POWER, NOTHING OPERATES

FAULTY POWER SWITCH
BATTERIES NEED CHARGING
FAULTY BATTERY
LOOSE BATTERY CABLE
MAIN CIRCUIT BREAKER TRIPPED

CONTACT LOCAL SERVICING DEALER
SEE CHARGING BATTERIES
REPLACE BATTERY
TIGHTEN LOOSE CABLE
WAIT 5 MINUTES FOR AUTO RESET
DETERMINE CAUSE AND CORRECT

BRUSH MOTOR DOES NOT OPERATE

GREEN BUTTON IS NOT DEPRESSED
CIRCUIT BREAKER TRIPPED

CARBON BRUSHES WORN
FAULTY BRUSH MOTOR OR WIRES

DEPRESS BUTTON ON HANDLE BAR
RESET & REDUCE PRESSURE
DETERMINE CAUSE AND CORRECT
CONTACT LOCAL SERVICING DEALER
CONTACT LOCAL SERVICING DEALER

VACUUM MOTOR DOES NOT OPERATE

FAULTY VACUUM SWITCH
CIRCUIT BREAKER TRIPPED

FAULTY VACUUM MOTOR
CARBON BRUSHES WORN

REPLACE SWITCH
RESET & CHECK HOSE
DETERMINE CAUSE AND CORRECT
CONTACT LOCAL SERVICING DEALER
CONTACT LOCAL SERVICING DEALER

INSUFFICIENT SOLUTION FLOW

SOLUTION TANK LOW
FLOW KNOB TURNED DOWN
SOLUTION FILTER CLOGGED
SOLUTION LINE CLOGGED

SOLUTION VALVE CLOGGED

REFILL SOLUTION TANK
TURN KNOB MORE OPEN
REMOVE COVER AND CLEAN
REMOVE AND BLOW OUT WITH
COMPRESSED AIR
REMOVE COVER AND CLEAN

TROUBLE SHOOTING

PROBLEM

CAUSE

SOLUTION

NO SOLUTION FLOW

NO SOLUTION IN TANK
SOLUTION SWITCH OFF
SOLUTION SCREEN CLOGGED
FAULTY SOLUTION SOLENOID
FAULTY SOLUTION SWITCH

FILL SOLUTION TANK
TURN SOLUTION SWITCH ON
REMOVE AND CLEAN SCREEN
CONTACT LOCAL SERVICING DEALER
CONTACT LOCAL SERVICING DEALER

POOR WATER RECOVERY

RECOVERY TANK IS FULL
BALL/SCREEN IS CLOGGED
VACUUM HOSE IS CLOGGED
SQUEEGEE IS CLOGGED
SQUEEGEE BLADE IS WORN
FAULTY VACUUM HOSE
VACUUM MOTOR GASKET TORN
TANK GASKET FAULTY
DRAIN PLUG LOOSE
VAC MOTOR FAULTY
BATTERY CHARGE LOW

EMPTY RECOVERY TANK
REMOVE SCREEN AND CLEAN
REMOVE DEBRIS
REMOVE DEBRIS
ROTATE OR REPLACE BLADES
CONTACT LOCAL SERVICING DEALER
CONTACT LOCAL SERVICING DEALER
CONTACT LOCAL SERVICING DEALER
TIGHTEN PLUG
CONTACT LOCAL SERVICING DEALER
CHARGE BATTERIES OVERNIGHT

POOR WATER RECOVERY ON TURNS

WIPERS WORN
WIPERS CHATTER
SQUEEGEE SWING IS BINDING
INCORRECT SQUEEGEE SIZE

REPLACE WIPER MATERIAL
TIGHTEN PIVOT POINTS
CONTACT LOCAL SERVICING DEALER
CONTACT LOCAL SERVICING DEALER

TIRES NOISY

BEARING DRY
FAULTY HUBS

GREASE BEARINGS
CONTACT LOCAL SERVICING DEALER

POOR TRACTION

EXCESSIVE BRUSH PRESSURE
WORN DRIVE TIRE
HEAVY SOAP CONCENTRATION

REDUCE PRESSURE WITH SWITCH
REPLACE TIRES
CONTACT LOCAL SERVICING DEALER

SHORT RUN TIME

BATTERIES RUN DOWN
BATTERIES STILL DOWN
BATTERIES LOW ON WATER

BATTERIES OVER CYCLED

CHARGE BATTERIES TWICE
CONTACT LOCAL SERVICING DEALER
FILL WITH DISTILLED WATER TO 3/4"
ABOVE THE LEAD PLATES
CONTACT LOCAL SERVICING DEALER

