



Madvac[®] LR50 – Compact Robotic Arm Litter Vacuum

The Madvac® LR50 Advantage

Protect Your Environment

The high profile Madvac® LR50 will show your citizens and businesses the commitment to clean and maintain litter in your environment.

Innovative Ergonomics

- **Ergo Design Vacuum with Multi-Directional Joystick Control**
 - Six position joystick for effortless use.
- **High Operation Seating for Safety and Visibility**
- **Full Instrumentation**
 - Operator friendly control panel gauges.

Industry-Leading Performance

- **Up to 12 mph (19km/h) Road Speed**
 - Faster and greater area coverage.
- **Front Wheel Drive**
 - 20" (508 mm) drive wheels climb 7" (178 mm) curbs with ease.
- **2900 CFM Vacuum Rating (82.12 CMM)** – Industry leading vacuum picks up the heaviest litter!
- **On and Off Road**
 - Access litter on grass areas, ground, asphalt and concrete.
- **Unequaled Suction**
 - Unrestricted airflow due to 2-stage litter and dust filtration.
- **All Welded Heavy Gauge Structural Steel Frame**
 - Built to last.

Efficient, Fast Collection

- **Vacuum Compacts Litter 2:1 Ratio**
 - Resulting in 100-120 gallons (378-454 L) into a single heavy-duty disposable / re-usable bag. Due to its straight-through suction system, litter is easily collected up to 6 times faster than manual litter picking.
- **Advanced 2 micron dust filtration (option)**
 - Keeps you, pedestrians and your environment clean.

Engineered for Greater Productivity

- **48" (1.2 m) Wide Vacuum Head (option)**
 - Cleans 105,00 sq.ft. (14,000 m2)/per hr.
- **Robotic Power Arm**
 - Makes litter picking effortless and injury free.
- **Bagless Debris System (option)**
 - Kevlar Liner
- **15 ft. (4.5 m) Extension Hose (option)** – Permits litter retrieval in hard-to reach areas.
- **4 Wheel Configuration**
 - 85" (2.2 m) overall length allows access to clean areas that are unreachable by other machines.

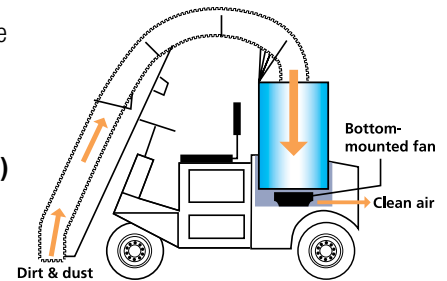

ABOVE
*Straight-Through Suction;
Dry / Humid / Wet Debris
Vacuumed;
No Debris passing through the Fan;
No Fan to Jam.*



LEFT
The ergonomic, 6-position robotic joystick-controlled vacuum arm results in productivity 6 times faster than a manual picker. It's "Turn on a Dime" turning radius allows fast and safe maneuvers in any environment.

For vacuum litter collecting sidewalks, walkways, plazas, public markets, alleyways and other areas with high pedestrian traffic, there's nothing quite like the LR50!

The Madvac® LR50 litter collector is used worldwide because: **It works. It lasts. It pays for itself. Fast!**



ABOVE
Robotic arm controlled via a joystick



TOP LEFT
48" (1.2 m) Wide Vacuum Head

TOP RIGHT
Handle tight spots with easy access for litter removal

LEFT
Superior rear visibility

The Friendly Vacuum Litter Collector

Efficient Cleaning

Expertly designed to meet the cleaning challenges of today's busy streets, the Madvac® LR50 is a high profile, cost-efficient cleaning machine that safely and effectively cleans city sidewalks, parks and streets. It even gets into confined, hard-to-reach places.

Exclusive Robotic Vacuum Arm

- **Robotic Vacuum Arm**
Easier operation eliminating fatigue and potential for workers' compensation claims.
- **270-Degree Arm Movement with 24 sq.ft. (2.2 m³) Working Area**
– Industry-leading accessibility to litter.

Safety Comes First

- **R.O.P.S. – Roll Over Protection System**
– Provides extra measure of safety.
- **340 Degree Rear Visibility**
– Lessens chance for serious accidents.
- **Cab Enclosure with Heater (option)**
– Keeps you dry and comfortable.
- **Heavy-Duty Coil Spring Rear Suspension**
– Means more comfort, better traction and a safer ride.
- **Complete Road Lighting and Signaling Package (option)**
– It's street legal.
- **All-Wheel Drive (option)**
– The first and only true off-road litter collector.

Protect your Environment

- **Noise Suppression Pack (option)**
– Only machine that quietly meets OSHA noise standards for continuous 8-hour shifts.
- **Plastic bottles no longer a public eyesore!**

Madvac[®] LR50

Compact Robotic Arm Litter Vacuum Technical Specifications

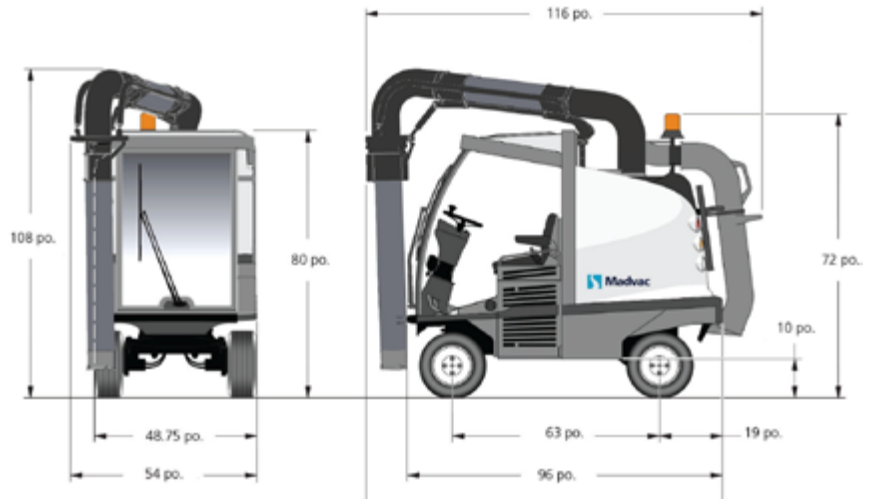

Data and Performance Information

Capacities		Vacuum System	
Fuel Tank	10.2 gal. (39 L) - 15 hours autonomy	Vacuum Rating	2,900 CFM (82.12 CMM)
Hydraulic System	12.5 gal. (48 L)	Air Flow Speed	8,400 ft./min (237.8/M/Min)
Litter Capacity	100 – 120 gal. (378 L – 454 L)	Static Pressure @ Closed Inlet	30 in. of water gauge (7.472 kPa)
Engine Data		Controls	
Model	Kubota Diesel D1105-E3B	Steering	Automotive type, power assisted
Displacement	68.53 cu in, (1123 cc)	Drive System	Heavy duty hydrostatic
Gross Rated Power	24.8 hp (18.5 kW) @ 3000 rpm	Traction	
Legislation Compliance	EPA Tier 4	Drive	Front wheel drive, optional four-wheel drive
Air Cleaner	2 stage Donaldson with restriction indicator	Maximum Forward Speed	12 mph (19 km/h)
Litter Collection System		Tire	20.5 x 8.0 – 10; 4 ply
Type	“Flow through” system with 2 to 1 compaction ratio, with reusable fibrous polypropylene bags	Brakes	Hydrostatic front brake Rear mechanical disc parking brake
Container Construction	16 gauge powder-coated steel	Curb Weight	2770 lbs (1256 Kg) including options
Vacuum Hose	8 in. (203 mm), joystick controlled	Suspension	
Frame/Body		Front	Multi-layer transverse, beam axle leaf springs with torsion bars
	Heavy gauge steel body on a welded ¼ in. structural steel frame	Rear	Heavy-duty shocks & springs
	Storage compartment		
	Electrostatic powder-coated paint		
Dimensions			
Width	48 in. (1219 mm)		
Length	96 in. (2438 mm)		
Height	108 in. (2743 mm)		
Wheelbase	63 in. (1600 mm)		
Ground Clearance	8 in. (203 mm)		

***Also available in LN50 model: with 2 position vacuum arm**



exprolink

Headquarters:
2170, De La Province
Longueuil (Quebec)
CANADA J4G 1R7

Toll Free 1 855 651-0444
Tel. 450 651-0444
Fax. 450 651-0447

www.exprolink.com