

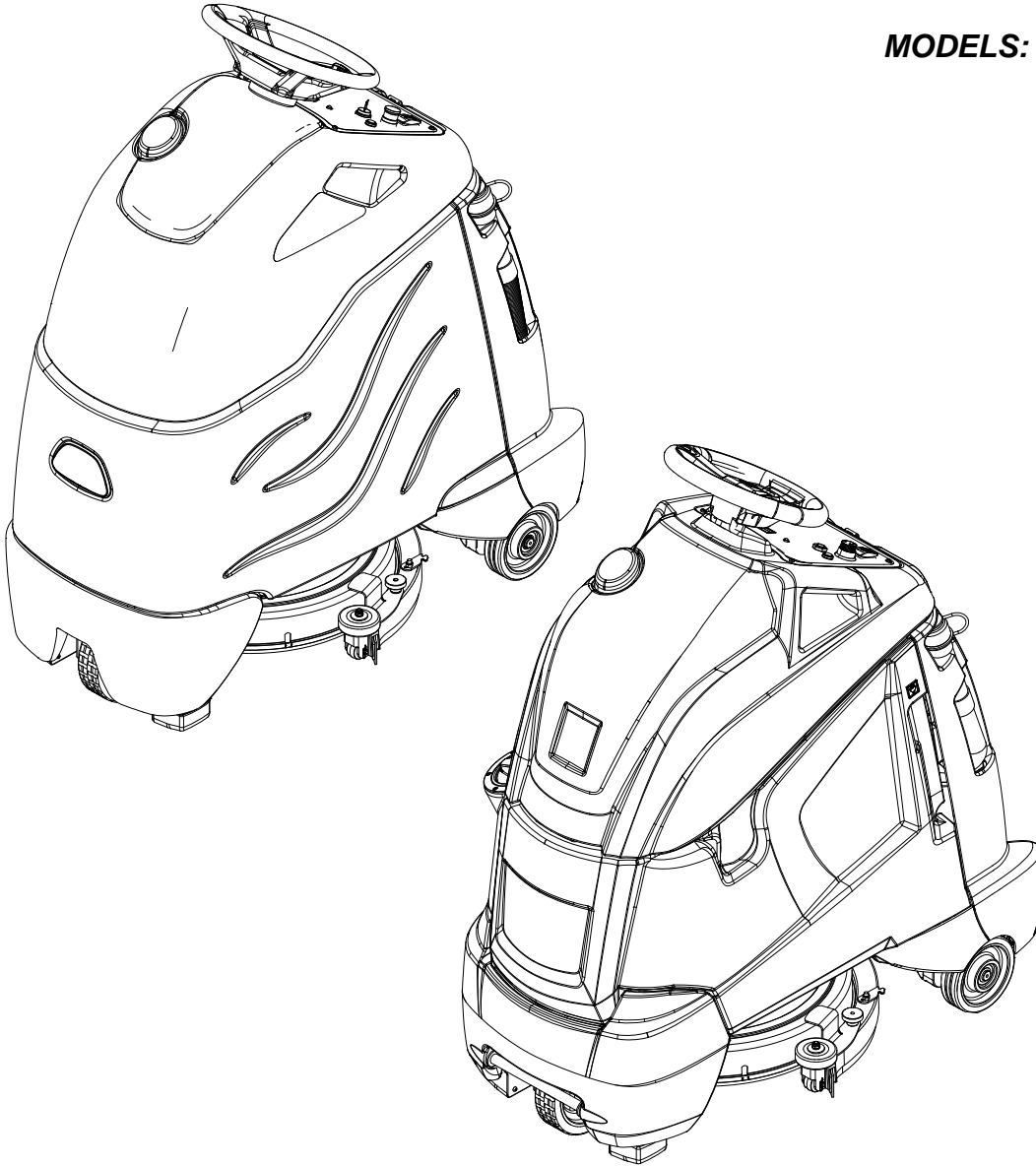

chariot

iScrub 20

Operating instructions (ENG)



MODELS: CS20
1.006-125.0

CSC20
1.006-133.0

CSX20
1.006-137.0

CSXC20
1.006-138.0

CS22SP
1.006-130.0

CSC22SP
1.006-134.0

**Prior to Serial Number (14*)
See Serial number page or call
manufacturer.**

Read these instructions before using the machine.



Model:	_____
Date of Purchase:	_____
Serial Number:	_____
Dealer:	_____
Address:	_____
Phone Number:	_____
Sales Representative:	_____

OVERVIEW

The Chariot Scrubber is a battery powered, stand-on, hard floor scrubber intended for commercial use. The appliance applies a cleaning solution onto a hard floor, scrubs the floor with brush or pad, and then vacuums the soiled water back into the recovery tank.

Warranty Registration

Thank you for purchasing a Windsor product. Warranty registration is quick and easy. Your registration will allow us to serve you better over the lifetime of the product.

To register your product go to :
www.windsorind.com/WarrantyRegistration.aspx
For customer assistance:
1-800-444-7654



Machine Data Log/Overview2

Table of Contents3

How to Use This Manual4

Safety

IMPORTANT SAFETY INSTRUCTIONS5

HAZARD INTENSITY LEVEL7

SAFETY LABEL LOCATIONS9

Operations

 Technical Specifications10

 How This Machine Works12

 Components13

 Drive Controls14

 Scrub Controls18

 Scrub Controls-Squeegee20

 Pre-Run Machine Inspection22

 Starting Machine22

 Emergency Stop Procedure22

 Filling Solution Tank22

 Filling Solution Tank (Deluxe)22

 Normal Scrubbing23

 To Begin Scrubbing23

 To Stop Scrubbing24

 Double Scrub24

 Emptying and Cleaning Tanks25

Maintenance

 Service Schedule26

 Batteries27

 Battery Charger Programming33

 To Remove Squeegee Assembly35

 Squeegee Blades-Cylindrical35

 Scrub Deck-Disk36

 Scrub Deck-Cylindrical36

 Scrub Brush-Disk37

 Replacing or Installing Scrub Brushes (Disk)38

 Replacing or Installing Scrub Brushes (Cylindrical)39

 To Replace Scrub Brush Motor - Disk40

 Scrub Deck Actuator Removal / Replacement42

 Circuit Protection43

 Solution44

 Tank Assembly Removal46

 Drive Unit Removal47

 Vacuum & Float Shutoff48

 Vacuum Motor Carbon Brush Replacement49

 Drive Motor50

 Drive Motor Carbon Brush Replacement50

Drive Chain Tension50

 Inclines51

 Machine Tie-Downs52

 Machine Tie-Downs (Deluxe)53

 Troubleshooting54

 Battery Discharge Indicator Troubleshooting56

Parts

Bumper58

Bumper-Deluxe & Cylindrical60

Console62

Control Panel 164

Control Panel 266

Decals - Disk68

Decals-Deluxe & Cylindrical70

Drive-Lower72

Drive-Chain74

Drive Mounting76

Frame & Rear Wheels78

On Board Battery Charger-Disk80

On Board Battery Charger-Deluxe & Cylindrical82

Pedal Platform84

Pedal Platform Mounting86

Recovery Tank88

Scrub Brush/Pad Driver90

Scrub Brush Deck-Disk92

Scrub Brush Deck Mounting-Disk94

Scrub Deck Drive Assembly-Cylindrical96

Scrub Deck-Cylindrical98

Scrub Deck Linkage-Cylindrical100

Scrub Brush Deck Mounting-Cylindrical102

Scrub Deck Lift104

Solution Tank106

Solution Tank-Deluxe108

Squeegee110

Squeegee-Cylindrical112

Squeegee Linkage-Cylindrical114

Steering116

Vacuum118

Wiring-Battery120

Wiring-Diagram -From Serial No. *(5)122

Wiring-Diagram -From Serial No. *(5)132

Wiring-Diagram -From Serial No. *(5)134

Wiring-Diagram -From Serial No. *(5)136

Wiring-Control Panel -Prior to Serial No. *(5)138

Wiring-Main Harness -Prior to Serial No. *(5)140

Wiring-Diagram -Prior to Serial No. *(5)142

Wiring-Diagram -Prior to Serial No. *(5)144

Suggested Spare Parts145

Serial Numbers146

How to Use This Manual

This manual contains the following sections:

- HOW TO USE THIS MANUAL
- SAFETY
- OPERATIONS
- MAINTENANCE
- PARTS LIST

The HOW TO USE THIS MANUAL section will tell you how to find important information for ordering correct repair parts.

Parts may be ordered from authorized Windsor dealers. When placing an order for parts, the machine model and machine serial number are important. Refer to the MACHINE DATA box which is filled out during the installation of your machine. The MACHINE DATA box is located on the inside of the front cover of this manual.

Model:	_____
Date of Purchase:	_____
Serial Number:	_____
Dealer:	_____
Address:	_____
Phone Number:	_____
Sales Representative:	_____

The model and serial number of your machine are located below the battery compartment of the machine.

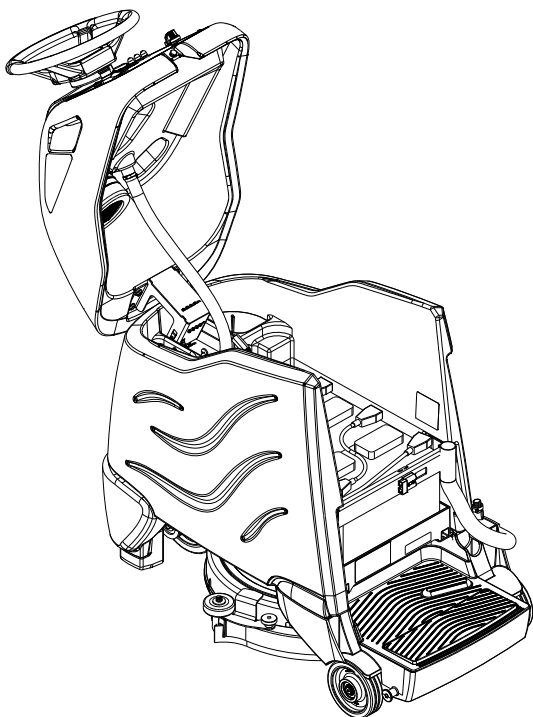

The SAFETY section contains important information regarding hazard or unsafe practices of the machine. Levels of hazards are identified that could

result in product or personal injury, or severe injury resulting in death.

The OPERATIONS section is to familiarize the operator with the operation and function of the machine.

The MAINTENANCE section contains preventive maintenance to keep the machine and its components in good working condition. They are listed in this general order:

- Batteries
- Scrub Brush
- Squeegee
- Service Schedule
- Machine Troubleshooting

The PARTS LIST section contains assembled parts illustrations and corresponding parts list. The parts lists include a number of columns of information:

REF - column refers to the reference number on the parts illustration.

PART NO. - column lists the part number for the part.

PRV NO. - Reference No.

QTY - column lists the quantity of the part used in that area of the machine.

DESCRIPTION - column is a brief description of the part.

SERIAL NO. FROM - If this column has an (*) and a Reference number, see the SERIAL NUMBERS page in the back of your manual. If column has two asterisk (**), call manufacturer for serial number.

The serial number indicates the first machine the part number is applicable to. The main illustration shows the most current design of the machine.

When a boxed illustration is shown, it displays the older design.

NOTES - column for information not noted by the other columns.

NOTE: If a service or option kit is installed on your machine, be sure to keep the KIT INSTRUCTIONS which came with the kit. It contains replacement parts numbers needed for ordering future parts.

The number on the lower left corner of the front cover is the part number for this manual.

IMPORTANT SAFETY INSTRUCTIONS

When using an battery powered appliance, basic precaution must always be followed, including the following:

 WARNING: READ ALL INSTRUCTIONS BEFORE USING THIS MACHINE.

To reduce the risk of fire, electric shock, or injury:

Use only indoors. Do not use outdoors or expose to rain.

Use only as described in this manual. Use only manufacturer's recommended components and attachments.

If the machine is not working properly, has been dropped, damaged, left outdoors, or dropped into water, return it to an authorized service center.

Do not operate the machine with any openings blocked. Keep openings free of debris that may reduce airflow.

This machine is not suitable for picking up hazardous dust.

Do not operate this machine near flammable fluids, dust or vapors.

Maintenance and repairs must be done by qualified personnel.

If foam or liquid comes out of machine, switch off immediately.

Disconnect battery before cleaning or servicing.

Before the machine is discarded, the batteries must be removed and properly disposed of.

Make sure all warning and caution labels are legible and properly attached to the machine.

During operation, attention shall be paid to other persons, especially children.

Before use all covers and doors shall be put in the positions specified in the instructions.

When leaving unattended, secure against unintentional movement.

The machine shall only be operated by instructed and authorized persons.

When leaving unattended, switch off or lock the main power switch to prevent unauthorized use.

Only chemicals recommended by the manufacturer shall be used.

This appliance has been designed for use with the brushes specified by the manufacturer. The fitting of other brushes may affect its safety.

Do not use on surfaces having a gradient of over 10% (6 degrees).

SAVE THESE INSTRUCTIONS

MESURES DE SÉCURITÉ IMPORTANTES

Lors de l'utilisation d'un appareil à batteries, il est nécessaire de respecter systématiquement des mesures de sécurité de base, comme suit :

⚠ AVERTISSEMENT: PRENEZ NOTE DE TOUTES CES MESURES AVANT D'UTILISER CETTE MACHINE.

Pour réduire les risques d'incendie, de chocs électriques, ou de blessures :

N'utiliser cette machine qu'en intérieur. Ne jamais l'utiliser à l'extérieur ou dans la pluie.

Utiliser cet appareil conformément aux instructions du présent manuel uniquement. N'utiliser que les composants et les accessoires conseillés par le fabricant.

Lorsque la machine ne fonctionnant pas correctement, a fait l'objet d'une chute ou d'une détérioration, a été laissée à l'extérieur, est tombée dans l'eau, la retourner au centre de service agréé.

Ne pas opérer la machine lorsque les conduits de ventilation sont bloqués. Débarrasser les débris des conduits, car ils peuvent réduire l'écoulement d'air.

Cette machine n'est pas adaptée au ramassage de poussières dangereuses

Ne pas l'utiliser près de liquides, de poussières ou de vapeurs inflammables.

L'entretien et les réparations de la machine doivent être effectuées par un personnel qualifié.

Si de la mousse ou du liquide sort de la machine, la mettre hors tension immédiatement.

Déconnecter les batteries avant de nettoyer la machine ou de la soumettre à un entretien.

Avant de se débarrasser de la machine, il est nécessaire de retirer les batteries et de les jeter correctement.

S'assurer que toutes les plaques d'avertissement ou de précaution sont lisibles et fixées correctement sur la machine.

Durant la manoeuvre de la machine, prendre garde aux personnes environnantes et notamment aux enfants.

Avant l'utilisation de la machine, veiller à positionner tous les couvercles et portes comme indiqué dans les instructions.

Lorsque la machine est laissée sans surveillance, s'assurer qu'elle ne se déplace pas de manière accidentelle.

Cette machine ne doit être manoeuvrée que par un personnel expérimenté et qualifié.

Lorsque la machine est laissée sans surveillance, la mettre hors tension ou verrouiller l'interrupteur principal afin d'empêcher un emploi non autorisé.

Seuls les produits chimiques recommandés par le fabricant doivent être utilisés.

Cette machine a été conçue pour être utilisée avec des brosses spécifiées par le fabricant.

L'utilisation d'autres brosses peut affecter sa sûreté.

N'employez pas sur des surfaces ayant un gradient de plus de 10% (6 degrés).

CONSERVER CES INSTRUCTIONS

The following symbols are used throughout this guide as indicated in their descriptions:

HAZARD INTENSITY LEVEL

There are three levels of hazard intensity identified by signal words -**WARNING** and **CAUTION** and **FOR SAFETY**. The level of hazard intensity is determined by the following definitions:

WARNING:

WARNING - Hazards or unsafe practices which **COULD** result in severe personal injury or death.

CAUTION:

CAUTION - Hazards or unsafe practices which could result in minor personal injury or product or property damage.

FOR SAFETY: To Identify actions which must be followed for safe operation of equipment.

Report machine damage or faulty operation immediately. Do not use the machine if it is not in proper operating condition. Following is information that signals some potentially dangerous conditions to the operator or the equipment. Read this information carefully. Know when these conditions can exist. Locate all safety devices on the machine. Please take the necessary steps to train the machine operating personnel.

FOR SAFETY:

DO NOT OPERATE MACHINE:

Unless Trained and Authorized.

Unless Operation Guide is Read and understood.

In Flammable or Explosive areas.

In areas with possible falling objects.

WHEN SERVICING MACHINE:

Avoid moving parts. Do not wear loose clothing; jackets, shirts, or sleeves when working on the machine. Use Windsor approved replacement parts.

WARNING:

Batteries emit hydrogen gas. Explosion or fire can result. Keep sparks and open flame away. Keep solution tank in raised position when charging. Keep sparks and flames away from the batteries. Do not smoke around batteries.

WARNING:

Disconnect batteries before working on machine. Only qualified personnel should work inside machine. Always wear eye protection and protective clothing when working on or near batteries. Avoid skin contact with the acid contained in the batteries.

WARNING:

Never allow metal to lie across battery tops.

Les symboles ci-dessous sont utilisés à travers ce manuel comme illustré dans leurs descriptions :

DEGRÉS DE RISQUES EN CAS DE DANGER

Il existe trois degrés de risques identifiés par les termes signalétiques -AVERTISSEMENT et ATTENTION et POUR VOTRE SÉCURITÉ. Le degré de risque est défini de la manière suivante:

⚠ AVERTISSEMENT:

AVERTISSEMENT - Dangers ou méthodes dangereuses qui POURRAIENT provoquer de graves blessures ou entraîner la mort.

⚠ ATTENTION:

ATTENTION - Dangers ou méthodes dangereuses qui pourraient provoquer des blessures légères ou une détérioration du produit ou des biens immobiliers.

POUR VOTRE SÉCURITÉ: ce signe permet d'identifier les mesures de précaution à prendre pour assurer un bon fonctionnement du matériel.

Rendre compte immédiatement d'une défaillance ou d'une détérioration de la machine. Ne pas utiliser la machine si celle-ci ne fonctionne pas correctement. Lire soigneusement les informations ci-dessous signalant certains dangers potentiels pour l'opérateur de la machine. L'opérateur doit être absolument au courant de ces dangers potentiels. Localiser tous les dispositifs de sécurité sur la machine. Il est conseillé de prendre les mesures nécessaires pour former le personnel opérateur.

POUR VOTRE SÉCURITÉ:

NE PAS MANOEUVRER LA MACHINE:

Lorsqu'on n'est pas expérimenté ou qualifié.

Lorsque le guide d'utilisation n'est pas été lu ou compris.

Dans des zones inflammables ou explosives.

Dans des zones où des objets peuvent tomber.

LORS DE L'ENTRETIEN DE LA MACHINE:

Éviter les parties amovibles. Ne pas porter de vêtements amples, tels que des vestes, des chemises ou des vêtements avec manches lors de l'utilisation de la machine. Utiliser les pièces détachées Windsor homologuées.

⚠ AVERTISSEMENT:

Les batteries émettent le gaz d'hydrogène. L'explosion ou le feu peut résulter. Étincelles de subsistance et flamme nue loin. Compartiment de batterie de subsistance ouvert en chargeant. Étincelles et flammes de subsistance loin des batteries. Ne fumez pas autour des batteries.

⚠ AVERTISSEMENT:

Déconnecter les batteries avant de travailler sur la machine. La machine ne doit être confiée qu'à un personnel qualifié. Porter systématiquement des lunettes et des vêtements de protection lors d'une intervention sur les batteries ou aux alentours. Éviter tout contact de la peau avec l'acide contenu dans les batteries.

⚠ AVERTISSEMENT:

Ne jamais placer d'objets métalliques sur le dessus des batteries.

SAFETY LABEL LOCATIONS

These drawings indicate the location of safety labels on the machine. If at any time the labels become illegible, promptly replace them.

EMPLACEMENT DE L'ÉTIQUETTE DE SÉCURITÉ

REMARQUE : Ces dessins indiquent l'emplacement des étiquettes de sécurité sur la machine. Si, à tout moment, les étiquettes deviennent illisibles, contactez votre représentant autorisé pour un remplacement rapide.

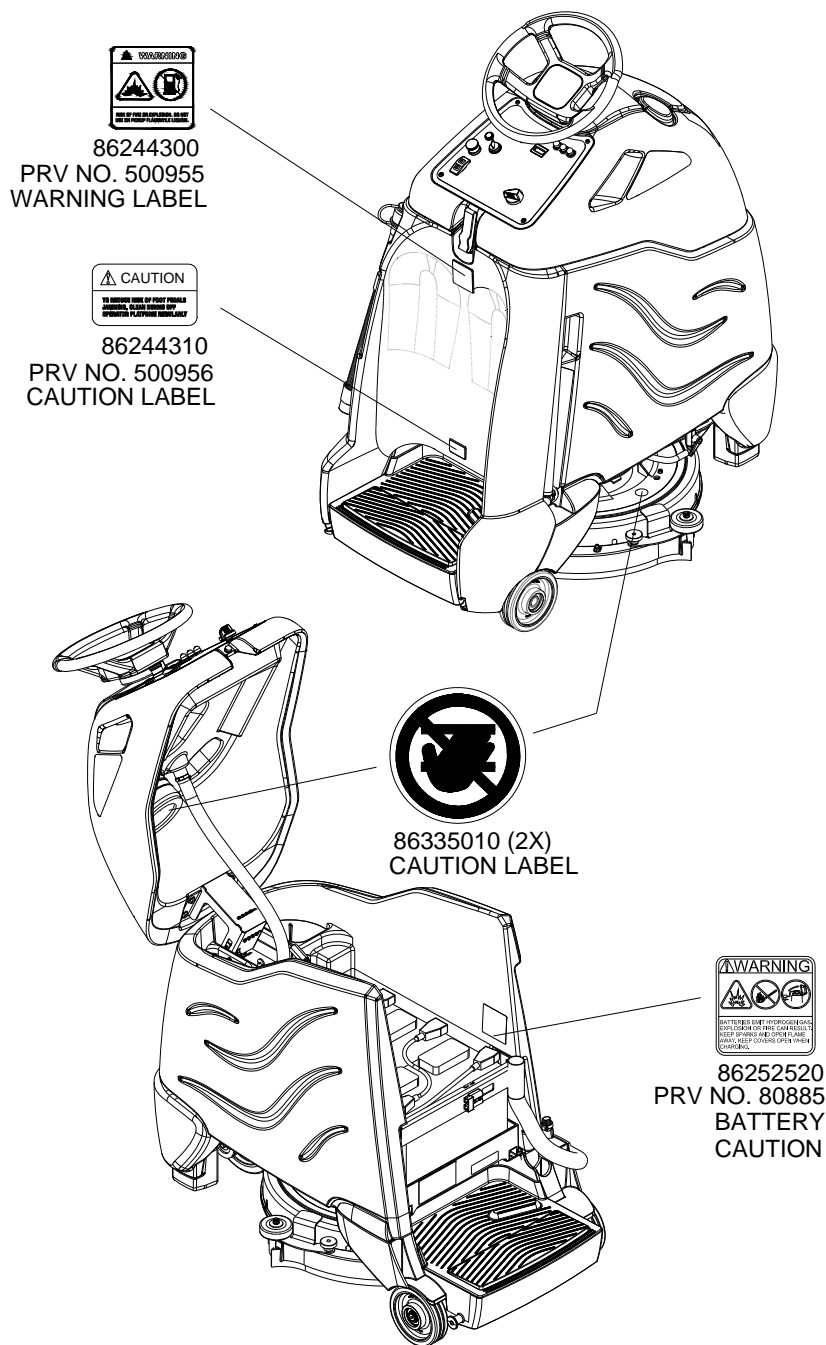

Technical Specifications

ITEM	DIMENSION/CAPACITY
Nominal Power-Disk	1080 W
Nominal Power-Cylindrical	1512 W
Rated Voltage	36 Volts DC
Rated Amperage -Disk	30 amps
Rated Amperage -Cylindrical	42 amps
Batteries	3 X12 Volt 130 AH @ 20 hr. rate
Battery Compartment Dimensions	20-1/2 in. x 13 in. x 10 in. tall (330mm x 521mm x 254mm)
Scrub Brush Motor - Disk Machine	1 x .28 HP (209 W)
Scrub Brush Motor - Cylindrical Machine	1 x .8 HP (600 W)
Vacuum Motor	.63 HP (470 W)
Maximum flow rate of vacuum motor	72 cfm (33.98 liters per second)
Maximum suction of vacuum motor	47.3 inches of water (11.7 kPa)
Propelling Motor	.21 HP (157 W)
Mass (GVW)	726 lbs (330 kg)
Weight empty without batteries - Disk	209 lbs (96 kg)
Weight empty without batteries - Cylindrical	255 lbs (116 kg)
Solution Control	Gravity, 1/3 GPM average
Solution capacity	10 gal (38 L)
Recovery capacity	10 gal (38 L)
Scrub brush diameter - Disk	20 inch (508 mm)
Scrub brush length - Cylindrical	22 inch (559 mm)
Scrub brush pressure - Disk	50 lbs (222N)
Scrub brush pressure - Cylindrical	46 lbs (21 kg)
Scrub brush speed - Disk	180 rpm
Scrub brush speed - Cylindrical	1500 rpm
Tires	8 in. (203mm) drive, 6 in. (156mm) rear, polyurethane
Maximum Speed	2.7 mph (4.3 Km/hour)
Brake	Electrical parking brake,sets automatically whenever operator stops.
Minimum aisle u-turn width	51in. (1295 mm)
Maximum rated climb and descent angle	10% (6 degrees)
Vibration, hands - Disk	1.6 m/s ²
Vibration, feet - Disk	0.54 m/s ²
Uncertainty - Disk	0.5 m/s ²
Sound pressure level - Disk	68.0 dBA
Sound power level - Disk	81.1 dBA
Uncertainty - Disk	3.0 dBA
Vibration, hands - Cylindrical	1.5 m/s ²
Vibration, feet - Cylindrical	0.9 m/s ²
Uncertainty - Cylindrical	0.5 m/s ²
Sound pressure level - Cylindrical	71.5 dBA
Sound pressure level - Cylindrical	84.7 dBA
Uncertainty - Cylindrical	3.0 dBA

ITEM	MEASURE
Height	51.8 in (1316mm)
Length	44.0 in (1118mm)
Width without squeegee - Disk	23.4 in (594mm)
Width without squeegee - Cylindrical	25.4 in (645mm)
Width of squeegee - Disk	27.2 in (691mm)
Width of squeegee - Cylindrical	29.3 in (744mm)
Width of scrub path - Disk	20 in (508mm)
Width of scrub path - Cylindrical	22 in (559mm)

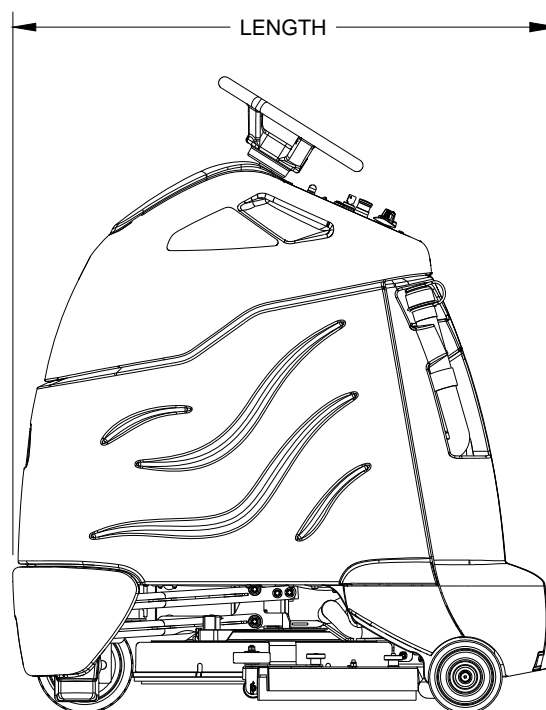
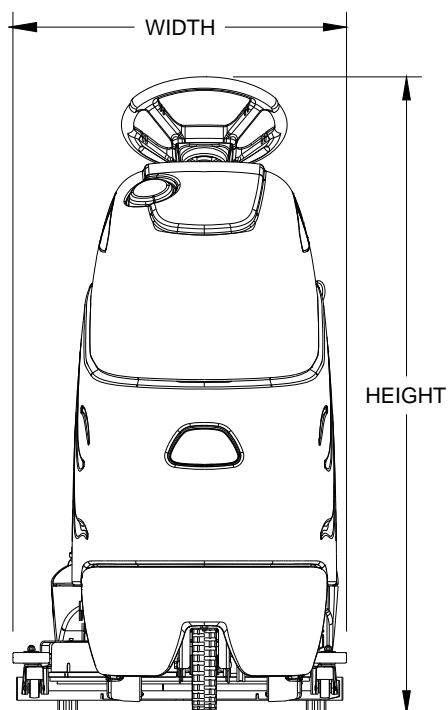

How This Machine Works

The Chariot® is a battery powered, self-propelled, hard floor scrubber intended for commercial use. The appliance applies a cleaning solution onto a hard floor, scrubs the floor with a brush, and then vacuums the soiled water back into the recovery tank.

The machine's primary systems are the solution system, scrub system, recovery system, and operator control system.

The function of the solution system is to store cleaning solution and deliver it to the scrub system. The solution system consists of the solution tank, strainer, metering valve and solenoid valve. The solution tank stores cleaning solution (water and detergent) until it is delivered to the scrub system. The strainer protects the valves from debris. The solenoid valve automatically prevents solution flow unless the scrub brush is turned on and the machine is being propelled.

The function of the scrub system is to scrub the floor.

The disk scrub system consists of one rotary type disk scrub brush, motor, scrub deck skirt and lift actuator. The brush scrubs the floor as the motor drives the brush. The brush drive hub allows the scrub brush to follow irregularities and changes in the floor without losing contact with the floor. The scrub deck skirt controls the cleaning solution on the floor so that the squeegee can pick it up.

The cylindrical scrub system consists of two cylindrical brushes, motor, side squeegees, and lift actuator. The two counter rotating brushes scrub the floor, driven by a single motor. The brush deck "floats" with constant brush pressure. The side squeegees keep the cleaning solution within the brush deck width, allowing the main squeegee to pick the solution up.

The function of the recovery system is to vacuum the soiled water back into the recovery tank. The recovery system consists of the squeegee, vacuum motor, float ball, recovery tank. The squeegee wipes the dirty solution off the floor as the machine moves forward. The vacuum motor provides suction to draw the dirty solution off the floor and into the recovery tank. The float ball filter protects the vacuum fan from debris and foam. The recovery tank stores the dirty solution.

The function of the operator control system is to control the direction and speed of the machine. The directional control system consists of the direction control drive reset switch, throttle pedal, emergency stop/brake switch, steering wheel, propel controller, and drive wheel. The directional control drive reset switch signals forward or reverse direction and makes sure the operator is on the platform before machine will propel. The controller interprets signals from the throttle pedal to command the drive wheel to propel or slow the machine. The steering wheel points the drive wheel in the direction desired by the operator. The parking brake automatically engages when the operator stop the machine. The emergency stop/brake can be used to hold the machine on slopes.

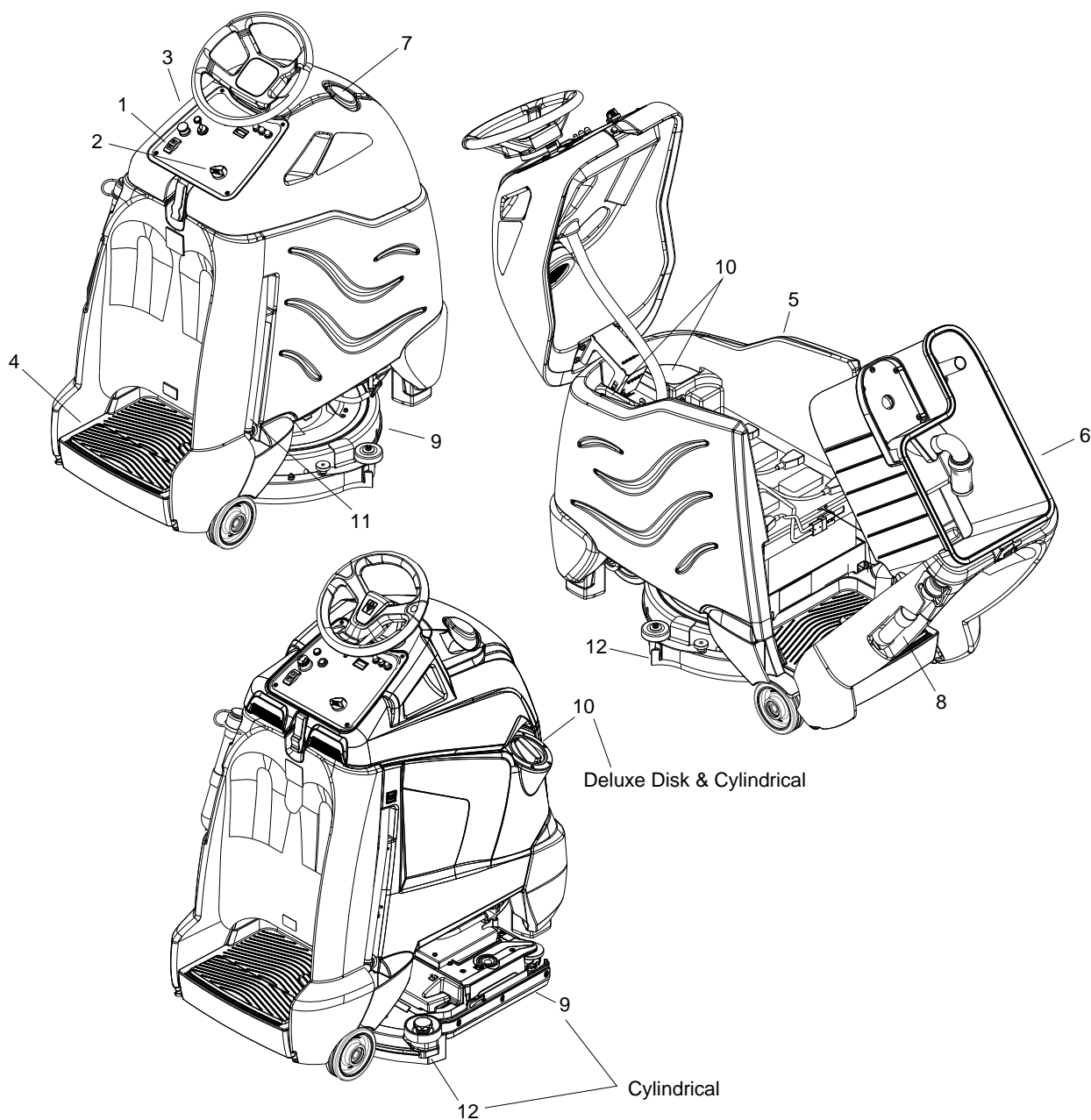

Components

- | | |
|----------------------------------------------------------------------------------------------------------------------------------------------------------------------------------------------------------|---------------------------------------------------------------------------------------------------------------------------------------------------------------------------------------------------------------------------------------------------|
| <ul style="list-style-type: none"> 1. Drive Control 2. Scrub Controls 3. Control Console 4. Pedal Platform 5. Solution Tank 6. Recovery Tank | <ul style="list-style-type: none"> 7. Recovery Sight Dome 8. Recovery Drain Hose 9. Scrub Deck Skirt 10. Solution Cover 11. Solution Drain Hose/Solution Level Indicator 12. Squeegee |
|----------------------------------------------------------------------------------------------------------------------------------------------------------------------------------------------------------|---------------------------------------------------------------------------------------------------------------------------------------------------------------------------------------------------------------------------------------------------|

Drive Controls

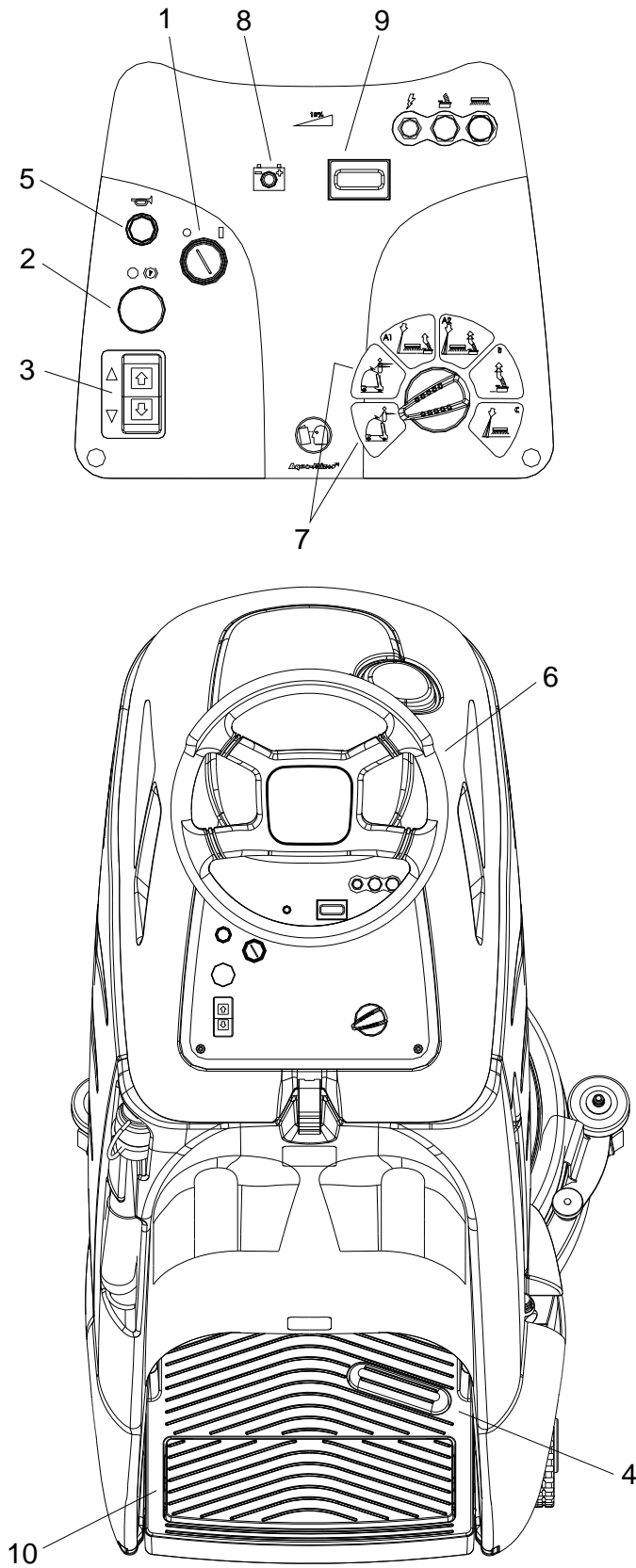

- | | |
|---------------------------------------------|--------------------------------|
| 1. Key Switch | 6. Steering Wheel |
| 2. Emergency Stop/Brake Switch | 7. Speed Control |
| 3. Directional Control / Drive Reset Switch | 8. Battery Discharge Indicator |
| 4. Throttle Pedal | 9. Hour Meter |
| 5. Horn Button | 10. Operator Presence Switch |
-

1. KEY SWITCH

Controls the power for machine functions.

To turn the machine power on, rotate key clockwise.

To turn the machine off, rotate key counterclockwise.

When the key is turned on the battery symbol will flash once and stay on continuously.

2. EMERGENCY STOP/BRAKE SWITCH

This safety feature is designed to cut all power to the machine at any time and apply parking brake.

To shut the machine power off, push the Emergency Stop Switch, this will also engage the parking brake and cause the machine to stop immediately.

To reset the machine, rotate the switch clockwise.

3. DIRECTIONAL CONTROL / DRIVE RESET SWITCH

This safety feature is designed to ensure safe engagement of propel drive. Each time the machine power is turned on, or each time an operator steps on to the platform, the Drive Reset Switch must be pushed before machine will propel.

The switch controls the direction of travel of the vehicle. The lighted arrow on the switch indicates direction of travel.

To travel forward, press the top of the switch.

To travel in reverse, press the bottom of the switch.

4. THROTTLE PEDAL

Controls the speed of the vehicle within the speed control setting selected. Pressing the pedal causes the machine to travel in the direction selected by the Directional Control Switch.

To increase speed, increase pressure on the pedal.

To decrease speed, decrease pressure on the pedal.

5. HORN BUTTON

The horn is activated by pressing the horn button.

6. STEERING WHEEL

The steering wheel turns the front wheel causing the machine to change direction.

7. SPEED CONTROL

Controls the maximum speed of the machine. There are two settings, slow and fast.

To change speed, rotate the dial to either slow or fast position. The slow position is to the left (counterclockwise), fast to the right (top position).

The throttle pedal will always regulate the speed between 0 and maximum.

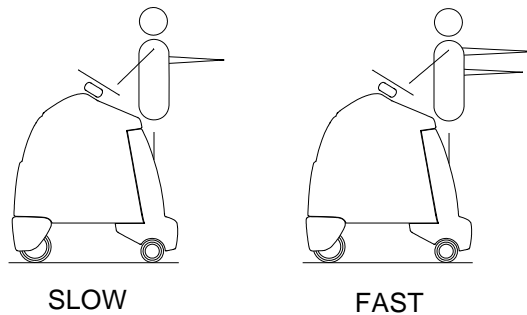

8. BATTERY DISCHARGE INDICATOR

Indicates the charge level of the batteries.

The indicator will be illuminated if the batteries have a sufficient charge. A slow, continuous flash indicates the batteries require charging.

The Battery Lockout function will activate when the batteries are low.

Once active, the LED status indicator will begin to flash slowly and the controller will inhibit the scrub motor and water solenoid. The vacuum and drive remain functional. The “vacuum only” selection (position ‘B’) can be used to vacuum up any remaining water. Return the unit to the charging station and charge the batteries.

NOTE: *Continuing usage may damage the batteries.*

When the machine is left overnight with less than a full charge, the display may initially indicate a full charge. It will also indicate a full charge if the batteries are disconnected, then reconnected. After a few minutes of operation the indicator will give the correct charge level.

9. HOUR METER

Records the number of hours the machine has been in scrubbing operation. This information is useful in determining when to service the machine.

Scrub Controls

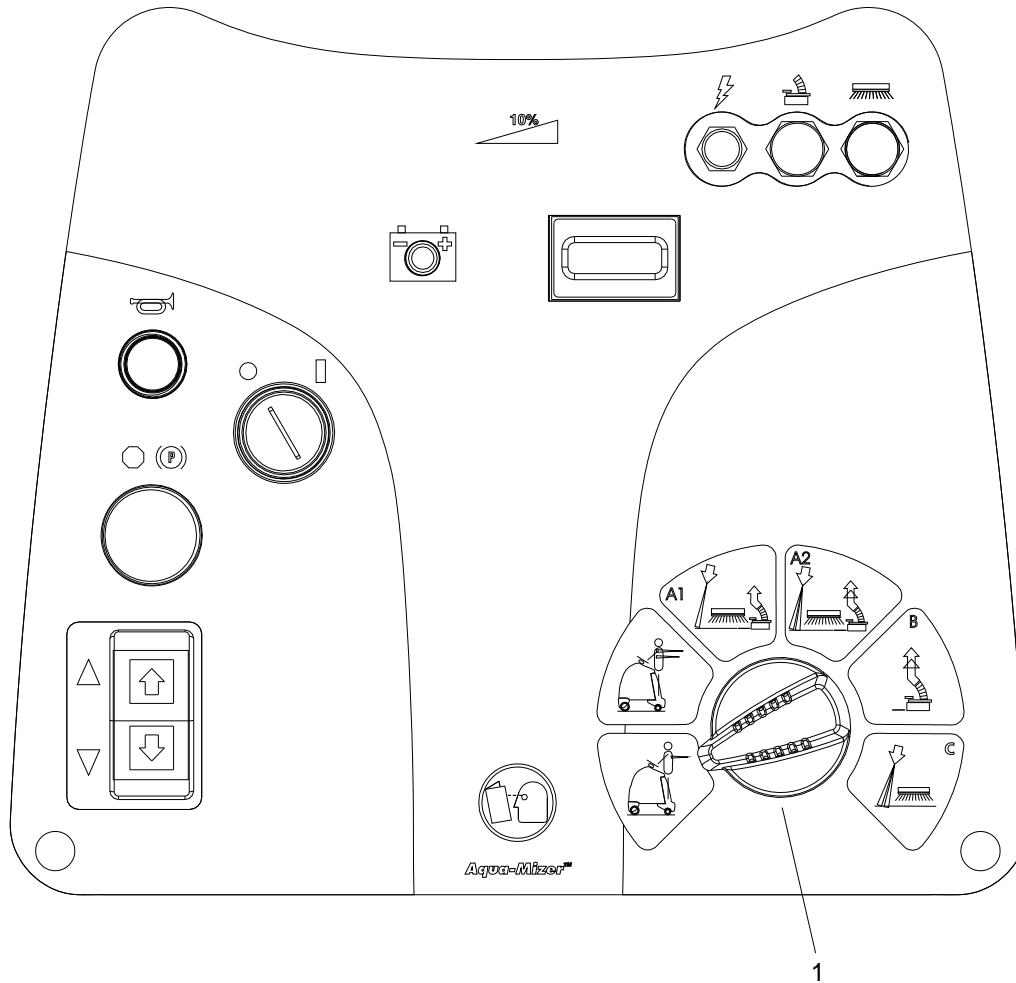

1. FUNCTION MODE SWITCH

The first two positions are for transport only. See drive controls section.

A1 - Light cleaning

This mode is used for light cleaning. In this mode the machine will propel at fast speed. The 'floating' scrub deck and squeegee is in the down position. The water will flow. Water will automatically shut off in neutral and restarts when scrubbing is resumed. The vacuum will draw the water into the recovery tank.

A2 - Deep cleaning

This mode is used for deep cleaning. In this mode the machine will propel at a low speed. The 'floating' scrub deck and squeegee is in the down position. The water will flow. Water will automatically shut off in neutral and restarts when scrubbing is resumed. The vacuum will draw the water into the recovery tank.

B - Vacuum only mode

This mode is used for picking up solution only. The brush and water will both be up and off. In this mode the machine will propel at fast speed. The squeegee is lowered and the vacuum will come on.

C - Double Scrub cleaning

This mode is used for putting down solution and scrubbing without picking it back up. The squeegee is set manually by connecting the two double scrub support cables. In this mode the machine will propel at a slow speed. The scrub deck will lower. The solution will flow. The brush and water will shut off when the machine is in neutral. They will resume when propelling is resumed.

Scrub Controls-Squeegee

DISK

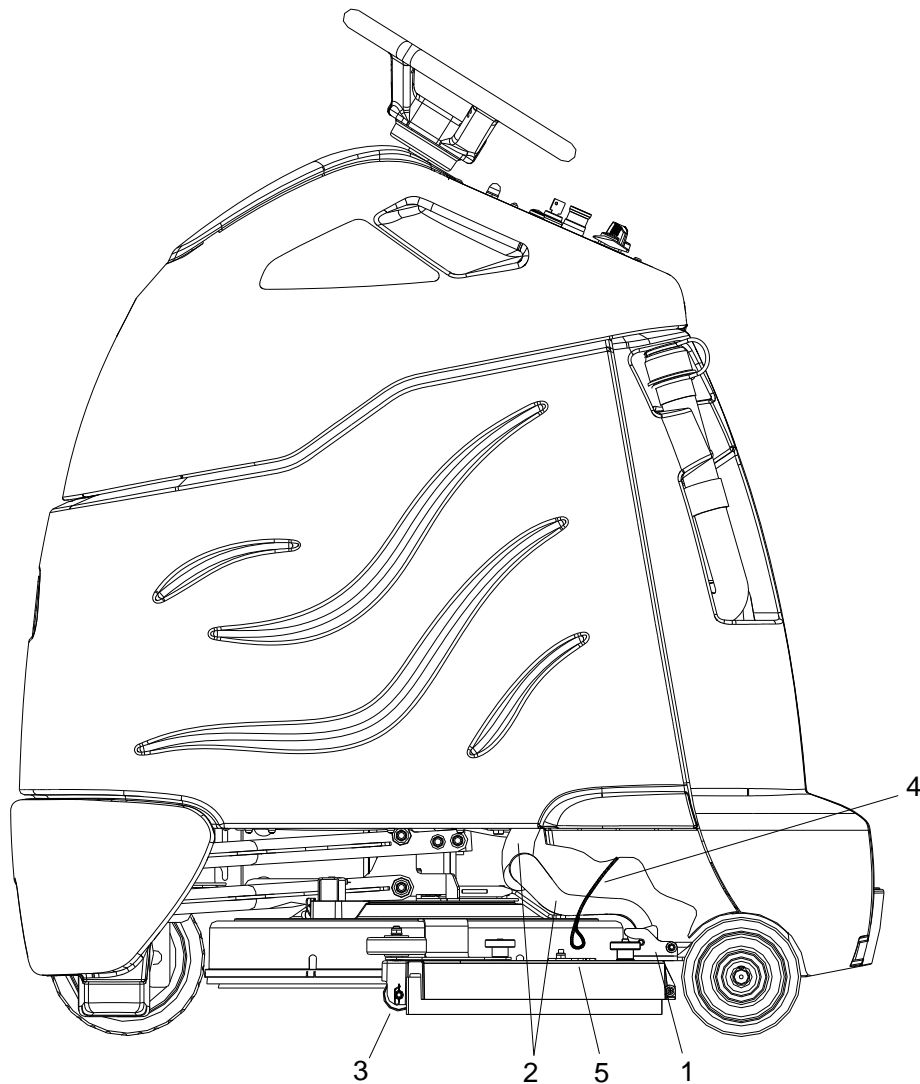

1. Squeegee Latch
2. Squeegee Hose and Tube
3. Squeegee Wheels (3)
4. Double Scrub Support Cable
5. Double Scrub Cable Hook

1. Squeegee Latch

The squeegee latch holds the squeegee in place.

2. Squeegee Hose and Tube

The squeegee hose and tube carry the recovered solution to the recovery tank.

3. Squeegee Wheels

The three squeegee wheels support the squeegee at the correct height and angle so that no adjustment is required.

4. Double Scrub Support Cable

The double scrub support cables retain the deck in the double scrub position.

5. Double Scrub Cable Hook

The double scrub cable hook is the connection point for the double scrub support cable. Since the squeegee is raised and lowered by the scrub deck, the double scrub position is set manually.

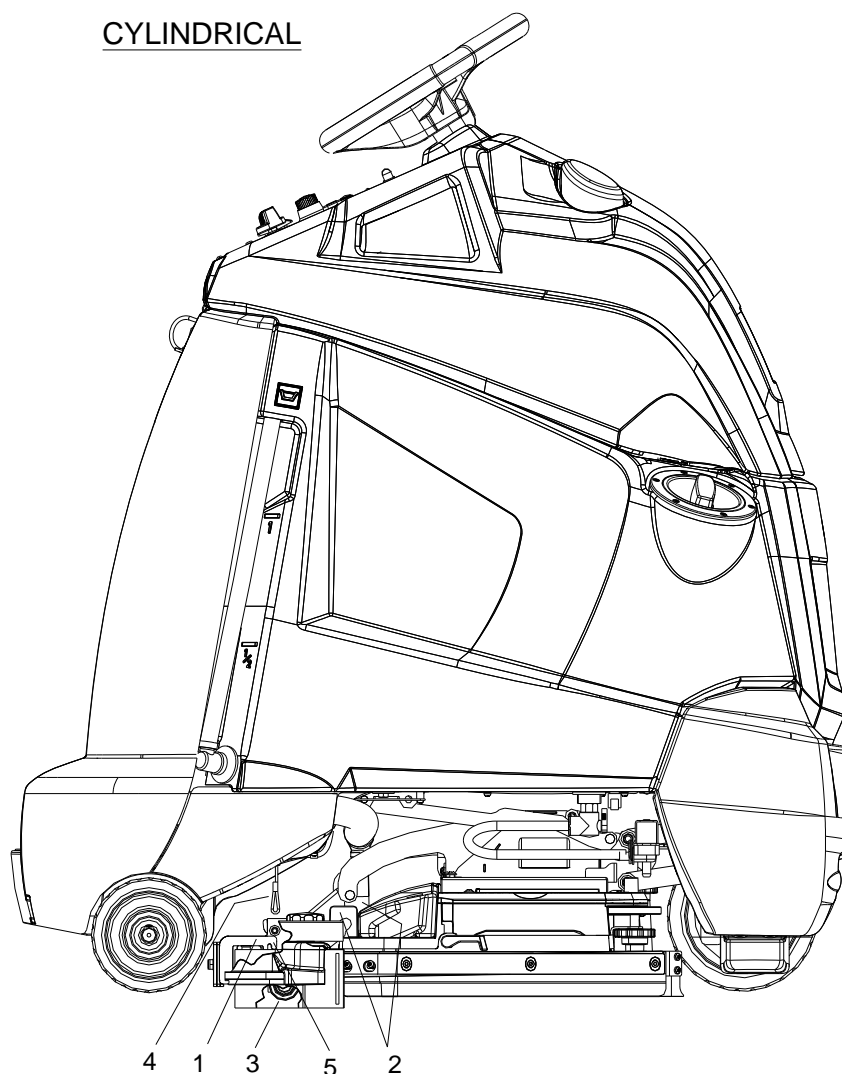

Machine Operation

Pre-Run Machine Inspection

Do a pre-run inspection to find possible problems that could cause poor performance or lost time from breakdown. Follow the same procedure each time to avoid missing steps.

NOTE: See maintenance section for pre-run machine inspection checklist items.

Starting Machine

NOTE: Perform pre-run machine check before operating machine.

FOR SAFETY: Before starting machine, make sure that all safety devices are in place and operating properly.

1. The operator should be on the pedal platform. The throttle pedal must be in the neutral position.
2. Turn the machine power on by turning key switch clockwise to the "ON" position.
3. Press the Drive Reset Directional Control Switch to reset and set the intended direction for travel.
4. Press lightly on the throttle pedal with right foot

Emergency Stop Procedure

Push in emergency stop button. This will also engage the parking brake and cause the machine to stop immediately.

Filling Solution Tank

FOR SAFETY: Before leaving or servicing machine; stop on level surface, turn off machine and remove key.

1. Turn the machine power off.
2. Tilt console forward. Push left or right fill port cover down. Fill the solution tank with clean water, leaving enough room for the required amount of cleaning solution. The solution tank capacity filled to fill inlet is 10 gallons (38 liters). The water must not be hotter than 140° F (60°C) to prevent damage to the tank

4. Measure the chemical into the solution tank. Liquid chemicals should be added to the solution tank after filling with water. Dry chemicals should be thoroughly mixed before being added into solution tank. Commercially available, high alkaline floor cleaners, are suitable for use in the solution system.

NOTE: Read the chemical manufacturers recommended proportion instructions.

5. Close console and latch rear cover.

⚠ WARNING:

Flammable materials can cause an explosion or fire. Do not use flammable materials in the tanks.

⚠ AVERTISSEMENT:

Les matières inflammables peuvent provoquer une explosion ou un incendie. Ne pas utiliser de matériaux inflammables dans les réservoirs.

Filling Solution Tank (Deluxe)

FOR SAFETY: Before leaving or servicing machine; stop on level surface, turn off machine and remove key.

1. Turn the machine power off.

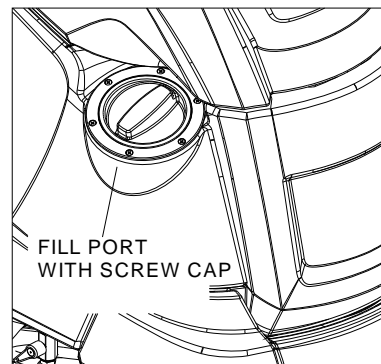

2. Using fill port, fill the solution tank with clean water, leaving enough room for the required amount of cleaning solution. The solution tank capacity filled to fill inlet is 10 gallons (38 liters). The water must not be hotter than 140° F (60°C) to prevent damage to the tank.

- Measure the chemical into the solution tank. Liquid chemicals should be added to the solution tank after filling with water. Dry chemicals should be thoroughly mixed before being added into solution tank. Commercially available, high alkaline floor cleaners, are suitable for use in the solution system.

Normal Scrubbing

Plan the scrubbing pattern in advance. The longest track is around the perimeter of the area to be cleaned. For efficient operation, the runs should be the longest possible without turning, stopping, or raising or lowering scrub deck/squeegee.

In order to achieve the best possible results, the area which is to be cleaned should be swept before scrubbing. Large debris, strings and wire must be removed to prevent being caught in brushes or squeegee.

If the machine is allowed to stand in neutral with the scrub deck down, the solutions flow stops and brush motor stops. If either forward or reverse travel is selected, the solution flow will continue in the same setting and the scrub brush motor will continue once movement of machine begins. Overlap the brush path and avoid transporting over previously cleaned areas.

INEFFICIENT SCRUBBING PATH

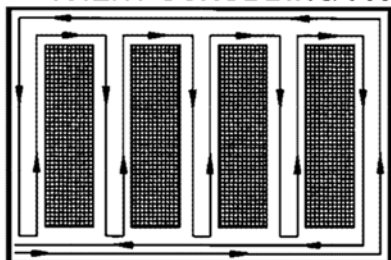

RECOMMENDED SCRUBBING PATH

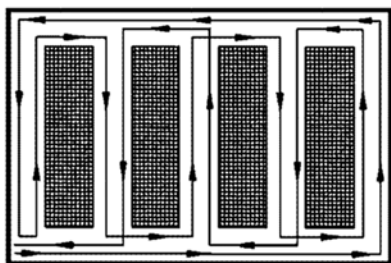

To Begin Scrubbing

⚠ WARNING:

When operating the machine around people, pay close attention for unexpected movement. Use extra caution around children.

⚠ AVERTISSEMENT:

Lorsque vous utilisez la machine en présence de gens, portez une attention particulière aux mouvements inattendus. Soyez plus prudent, surtout en présence d'enfants.

⚠ WARNING:

Flammable liquids and/or reactive metals can cause explosions or fire! Do not pick up.

⚠ AVERTISSEMENT:

Les liquides inflammables et / ou les métaux réactifs peuvent provoquer des explosions ou un incendie ! Ne les ramassez pas.

- Stand on the operator platform. Throttle pedal must be in neutral position.
- Turn machine power on.
- Press the Drive Reset / Directional Control Switch, selecting the desired travel direction.
- Position the function control knob to the desired operation. The scrub deck and squeegee will lower, and the vacuum will turn on.
- Drive machine forward to begin scrubbing. The scrub brush motor will run and solution will flow when the throttle is depressed.

NOTE: Shut machine off immediately if water or foam is expelled from the machine. Solution flow is automatically shut off when brush motor stops. When brush motor is activated, flow automatically resumes.

To Stop Scrubbing

1. Rotate the function knob to either transport position. The brush motor and vacuum will stop and the scrub deck will rise to the park position.
2. Allow the throttle pedal to return to neutral.
3. Turn machine power off.

NOTE: FOR SAFETY: Before leaving or servicing machine: stop on level surface, turn off machine and remove key.

Double Scrub

Floors which are heavily soiled or have thick accumulations of floor finish may not clean sufficiently with one pass. In these cases it will be necessary to double scrub.

Connect the Double Scrub Cables to the squeegee.

Rotate the knob to the double scrub position.

To support the squeegee off the floor for double scrub, pull the support cables down, one side at a time, and connect to the hook on the squeegee while lifting and tilting the squeegee upward.

To collect the solution and complete the Double Scrub operation, release both squeegee cable and turn the function knob to one of the normal scrubbing modes.

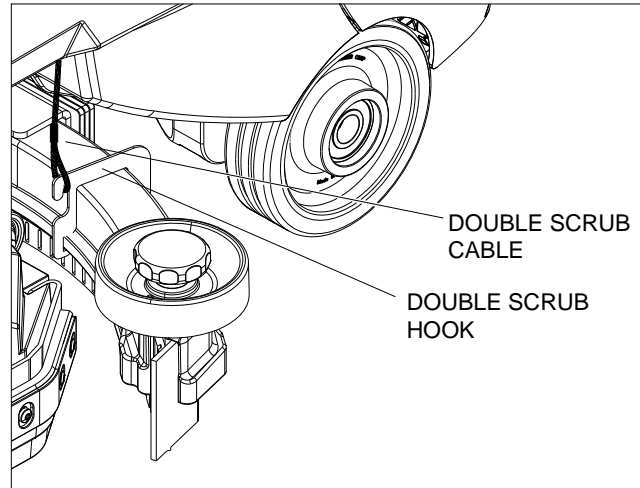

Cylindrical Machine

NOTE: *The deck and squeegee must be in the up position to hook the cables.*

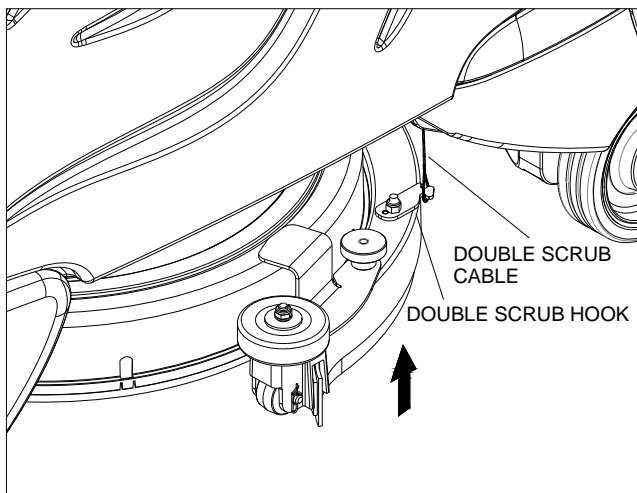

Disk Machine

Emptying and Cleaning Tanks

1. Park the machine next to a floor drain. Drain hoses are at the rear of the machine.
2. Turn the machine power off.

Recovery Tank

1. Pull the recovery drain hose from the mounting pocket. Lift cap, pinch hose then lower hose in direction of the drain. Do not stand in front of end of hose. Recovered solution will come out with force.
2. To flush the recovery tank, lift the control console to access the recovery tank. Do not use water hotter than 140°F (60°C) to clean tank. Damage may occur.
3. Clean debris from sight dome and cover surface.
4. Clean off the float shut-off screen and inspect for free movement of float.
5. Replace the drain cap and secure drain hose.
6. If machine is to be stored, tilt the recovery tank back and prop the console up, partially opening each.

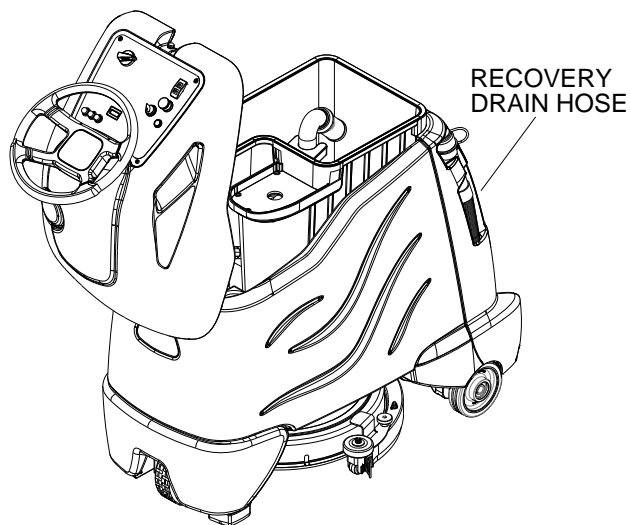

Solution Tank

1. Pull the solution drain hose from its mounting pocket. Lower hose in direction of drain.
2. Open the control console.
3. Flush the solution tank out with clean water and run several gallons of clean water through systems. Do not use water hotter than 140°F (60°C) to clean tank. Damage may occur.

NOTE: Never allow solution to remain in tank. Damage to tank, seals and valves could occur.

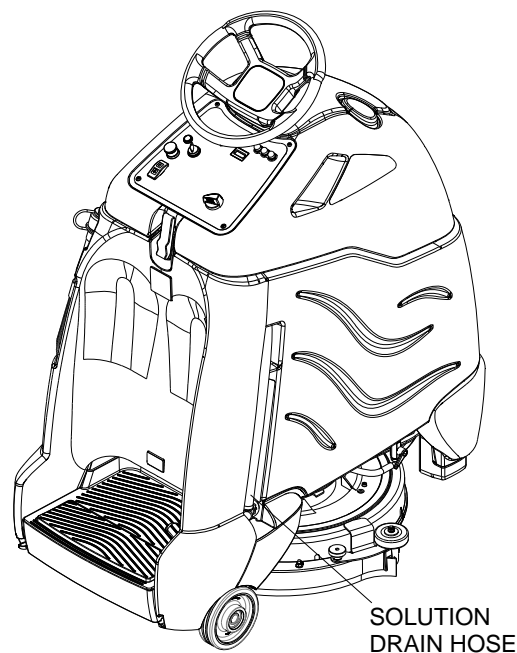

STORAGE POSITION

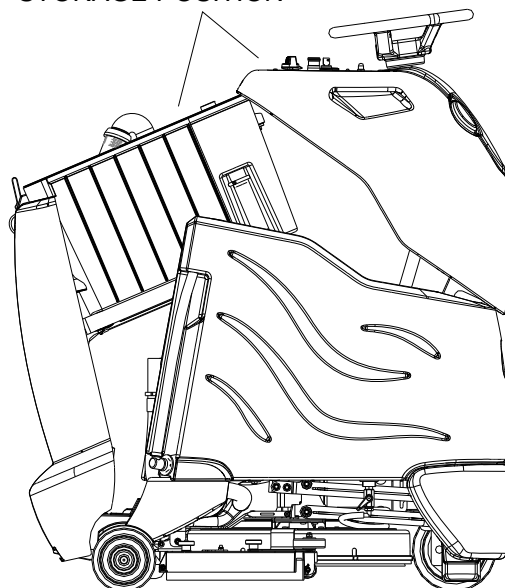

Service Schedule

MAINTENANCE	BEFORE EACH WORK PERIOD	AFTER EACH WORK PERIOD	50 HRS	100 HRS	200 HRS
Check water level of batteries after charging; add distilled water if necessary. (Wet cell only)	*				
Visually check for damaged or worn tires.	*				
Check brush or pad for proper installation.	*				
Check vacuum hose connections.	*				
Check that squeegee is securely attached.	*				
Check for securely attached drain hoses, plug and cap.	*				
Check pedal, brake and steering for proper operation.	*				
Clean out recovery tank.		*			
Clean and inspect float shutoff.		*			
Clean out solution tank.		*			
Clean and inspect solution filter strainer.		*			
Run vacuum motor to dry.		*			
Clean brush or pad and check wear.		*			
Clean squeegee blades and check wear.		*			
Clean outside of tanks, check for damage.		*			
Store with console cover propped open.		*			
Charge batteries if needed.		*			
Clean off top of batteries.			*		
Check battery cells with hydrometer. (Wet cell only)			*		
Inspect scrub deck skirt.			*		
Clean solution strainer inside tank.			*		
Check battery connections are tight.			*		
Clean battery cases and battery compartment.				*	
Check parking brake.					*
Clean pivot points on squeegee and scrub deck.					*
Check all motors for carbon brush wear.					*
Check motor commutators.					*
Check steering chain tension.					*
Check drive chain tension.					*

Batteries

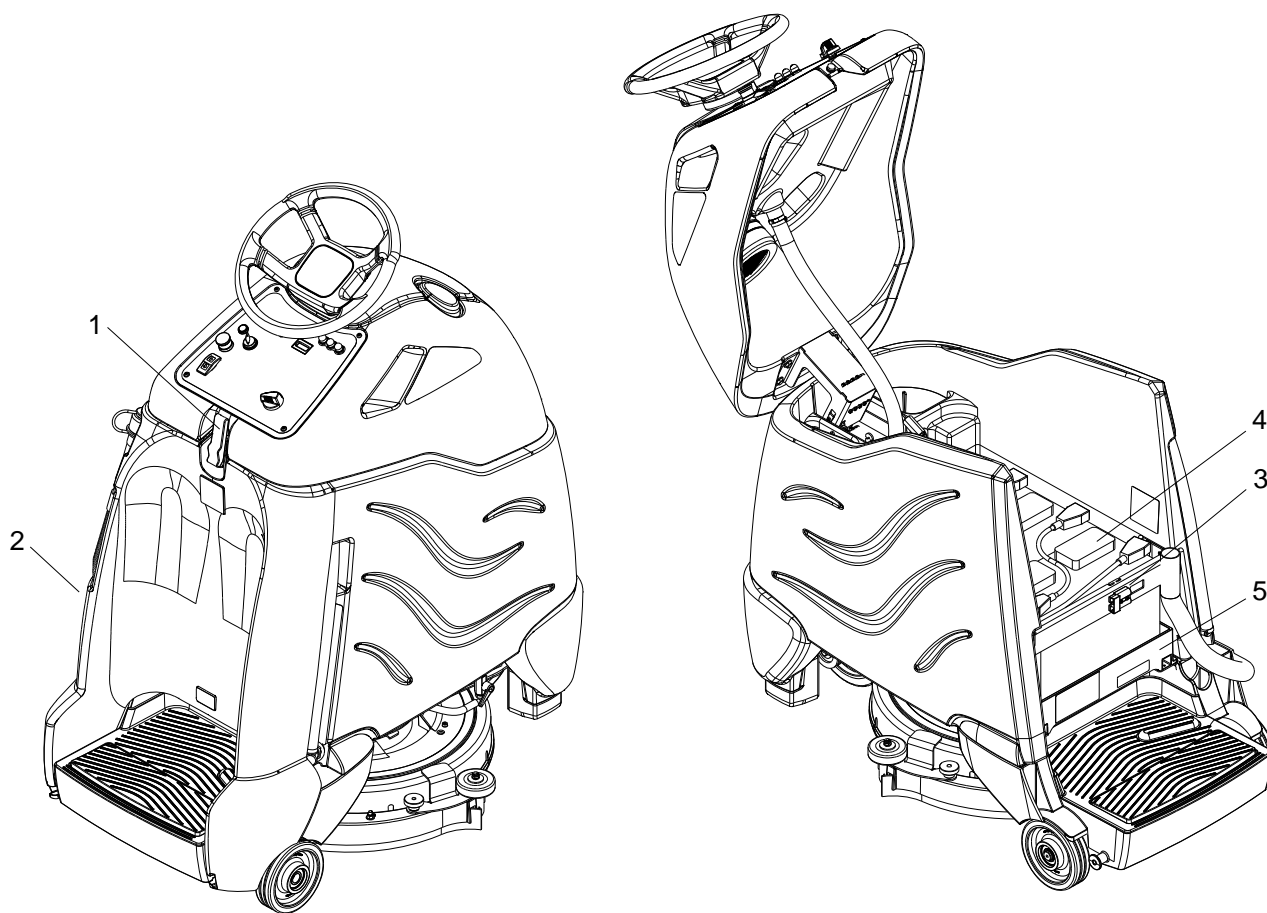

1. Cover Retainer Latch
2. Rear Cover
3. Battery Connector-Machine
4. Batteries
5. Battery Tray

Batteries (Wet Cell)

The batteries provide the power to operate the machine. The batteries require regular maintenance to keep them operating at peak efficiency.

The machine batteries will hold their charge for long periods of time, but they can only be charged a certain number of times. To get the greatest life from the batteries, charge them when their charge level reaches 25% of a full charge. Use a hydrometer to check the charge level.

Do not allow the batteries to remain in a discharged condition for any length of time. Never expose a discharged battery to temperatures below freezing. Discharged batteries will freeze causing cracked cases. Do not operate the machine if the batteries are in poor condition or if they have a charge level below 25% (specific gravity below 1.155).

Keep all metallic objects off the top of the batteries, as they may cause a short circuit. Replace worn or damaged cables and terminals.

Check the electrolyte level in each battery cell before and after charging the batteries. Never add acid to the batteries, use distilled water. Do not allow water level to fall below the battery plates. Portions of plates exposed to air will be destroyed. Do not overfill. Keep plugs firmly in place at all times.

WARNING:

Not all batteries require maintenance. AGM batteries are maintenance free. Do not attempt to remove sealed caps from AGM batteries. Warranty is void if caps are removed from AGM battery.

AVERTISSEMENT:

L'entretien n'est pas nécessaire pour toutes les batteries. Les batteries AGM ne nécessitent pas d'entretien. N'essayez pas d'enlever les bouchons scellés des batteries AGM. La garantie est annulée si les bouchons sont retirés des batteries AGM.

⚠ CAUTION:

When servicing machine, avoid contact with battery acid.

⚠ ATTENTION:

Lors de l'entretien de la machine, évitez tout contact avec l'acide de batterie.

⚠ WARNING:

Batteries emit hydrogen gas. Explosion or fire can result. Keep sparks and open flame away. Keep covers open when charging.

⚠ AVERTISSEMENT:

Les batteries émettent du gaz hydrogène. Une explosion ou un incendie peut en résulter. Maintenez les étincelles et les flammes nues à l'écart. Gardez les carters ouverts lors du chargement.

⚠ WARNING:

Wear eye protection and protective clothing when working with batteries.

⚠ AVERTISSEMENT:

Portez des lunettes de protection et des vêtements de protection lorsque vous travaillez avec des batteries.

⚠ WARNING:

Charge batteries in a well ventilated area.

⚠ AVERTISSEMENT:

Chargez les batteries dans un endroit bien ventilé

Battery Maintenance

1. When cleaning the batteries, use a solution of baking soda and water. Do not allow the cleaning fluid to enter the battery cells, electrolyte will be neutralized.
2. Maintain the proper electrolyte level in each battery cell. If a cell should accidentally overflow, clean immediately.
3. Wipe off the top of the batteries at least once a week.
4. Test battery condition with a hydrometer at least once a week.
5. Ensure that all connections are tight and all corrosion removed.
6. Every 4 to 6 months, remove the batteries from the machine and clean the battery cases and battery compartm

Checking Battery Specific Gravity

Use a hydrometer to check the battery specific gravity.

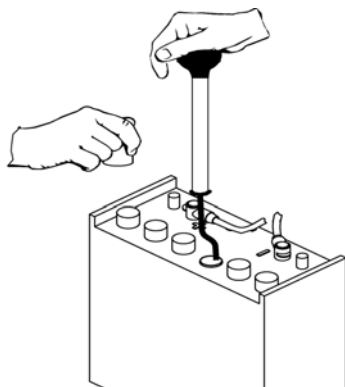

CHECKING GRAVITY

- a. Hydrometer Battery
- b. Battery

NOTE: Do not take readings immediately after adding distilled water, if the water and acid are not thoroughly mixed, the reading may not be accurate.

Check the hydrometer readings against this chart.

SPECIFIC GRAVITY @ 80° F (27°C)	BATTERY CONDITION
1.265	100% CHARGED
1.225	75% CHARGED
1.190	50% CHARGED
1.155	25% CHARGED
1.120	DISCHARGED

NOTE: If the readings are taken when the battery electrolyte is any temperature other than 80°F (27°C), the reading must be temperature corrected.

To find the corrected specific gravity reading when the temperature of the battery electrolyte is other than 80°F (27°C): Add (+) to the specific gravity reading 0.004 (4 points), for each 10°F (6°C) above 80° (27°C). Subtract (-) from the specific reading 0.004 (4 points), for each 10°F (6°C) below 80°F (27°C).

Charging Batteries

⚠ CAUTION:

When servicing machine, avoid contact with battery acid.

⚠ ATTENTION:

Lors de l'entretien de la machine, évitez tout contact avec l'acide de batterie.

⚠ WARNING:

Batteries emit hydrogen gas. Explosion or fire can result. Keep sparks and open flame away. Keep covers open when charging.

⚠ AVERTISSEMENT:

Les batteries émettent du gaz hydrogène. Une explosion ou un incendie peut en résulter. Maintenez les étincelles et les flammes nues à l'écart. Gardez les carters ouverts lors du chargement.

⚠ WARNING:

Wear eye protection and protective clothing when working with batteries.

⚠ AVERTISSEMENT:

Portez des lunettes de protection et des vêtements de protection lorsque vous travaillez avec des batteries.

⚠ WARNING:

Charge batteries in a well ventilated area.

⚠ AVERTISSEMENT:

Chargez les batteries dans un endroit bien ventilé

Use a 36 volt, 20 amp maximum output DC charger which will automatically shut off when the batteries are fully charged.

1. Stop the machine in a clean, well ventilated area next to the charger.
2. Turn "OFF" machine.

FOR SAFETY: Before leaving or servicing machine; stop on level surface, turn off machine and remove key.

3. Open rear cover, unplug batteries from machine.

⚠ WARNING:

Batteries emit hydrogen gas. Explosion or fire can result. Keep sparks and open flame away. Keep covers open when charging.

⚠ AVERTISSEMENT:

Les batteries émettent du gaz hydrogène. Une explosion ou un incendie peut en résulter. Maintenez les étincelles et les flammes nues à l'écart. Gardez les carters ouverts lors du chargement.

4. Check the electrolyte level in each battery cell. Before charging, add just enough distilled water to cover the plates. After charging is complete, add just enough distilled water to bring up the level to the indicator ring. If the water level is too high before charging, normal expansion rate of the electrolyte may cause an overflow resulting in a loss of battery acid balance and damage the machine.

Maintenance

5. Replace the battery caps, and leave them in place while charging.
6. Unplug the battery connector from the machine.

FOR SAFETY: When charging, connect the charger to the batteries before connecting the charger to the AC wall outlet. Never connect the charger to the AC wall outlet first. Hazardous sparks may result.

7. Plug the charger connector into the battery connector. Connect the charger AC plug to a wall outlet. The charger gauge should indicate that the batteries are charging.
8. When the batteries are fully charged, disconnect the charger from the AC wall outlet, then disconnect the charger from the batteries.
9. Connect the batteries to the machine connector.
10. Check the electrolyte level. It should be up to the indicator ring. If necessary, add distilled water.
11. Install the rear cover. Changing Batteries

Stop the machine in a clean area next to the charger. Turn off machine.

FOR SAFETY: Before leaving or servicing the machine; stop on level surface, turn off machine and remove key.

1. Open the console cover.
2. Tilt the rear cover/recovery tank back. The rear cover/recovery tank can also be removed for better access.
3. If equipped with optional on board charger, tilt charger mount to rear of machine.
4. Disconnect battery pack from machine.
5. Use the proper size open end wrench to disconnect main ground wire first and secure cable terminal away from batteries.

6. Disconnect main positive lead and secure cable terminals away from batteries.
7. Loosen both terminals on each jumper cable and remove one at a time.
8. Prepare a suitable site to place the batteries.

⚠ WARNING:

Attach suitable battery lifting device and lift batteries from the machine. Batteries are a potential environmental hazard. Consult your battery supplier for safe disposal methods.

⚠ AVERTISSEMENT:

Fixez le dispositif de levage de batterie approprié et levez les batteries de la machine. Les batteries constituent un danger potentiel pour l'environnement. Consultez le fournisseur de votre batterie pour connaître les méthodes d'élimination sûres.

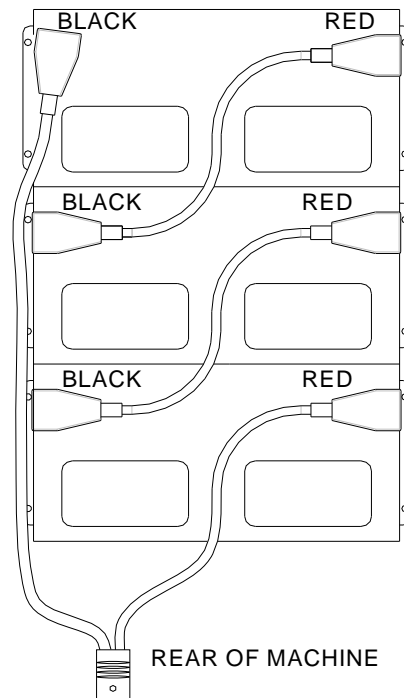

Battery Charger Programming

NOTE: For machines equipped with optional on-board charger. When replacing batteries, charger programming changes may be required. If replacing batteries with same type, (e.g. maintenance free batteries with maintenance free) no programming is required. When batteries with different type (e.g. maintenance free with wet cell), programming changes are required. Failure to make programming changes may lead to reduced battery life.

Switching From Wet Cell to Maintenance Free Batteries

Program charger from normal mode (red LED flashes) to alternate mode (Red and green LED's flash):

1. Disconnect battery charger from outlet.
2. Connect (+) wire from EZlamp to (+) charger battery cable.

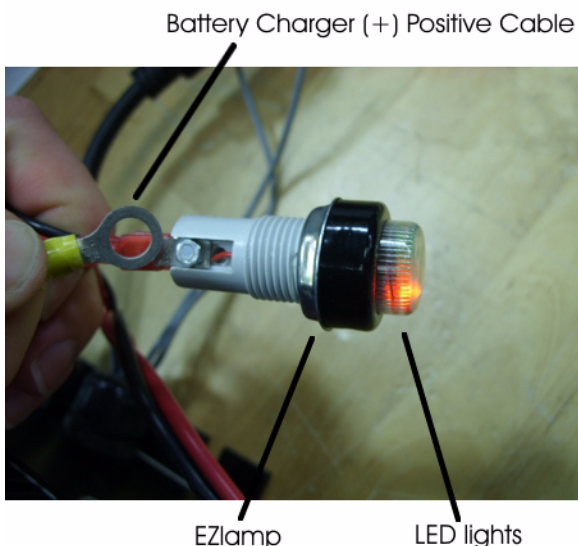

3. Connect AC cord to outlet. All LED's should be on.

NOTE: If Red and green LED's do not flash, repeat steps 1 and 2.

4. Wait 5 seconds, disconnect wires and unplug charger.
5. Programming is complete.

Switching From Maintenance Free to Wet Cell Batteries

Program charger from alternate mode (All LED's flash) to normal mode (red LED flashes):

1. Disconnect battery charger from outlet.
1. Connect (+) wire from EZlamp to (+) charger battery cable.
2. Connect AC cord to outlet. Red LED should be on.

NOTE: If Red LED light does not flash, repeat steps 1 and 2.

3. Wait 5 seconds, disconnect wires and unplug charger.
4. Programming is complete.

NOTE: Battery Charger must be approved to 60335-2-29 standard.

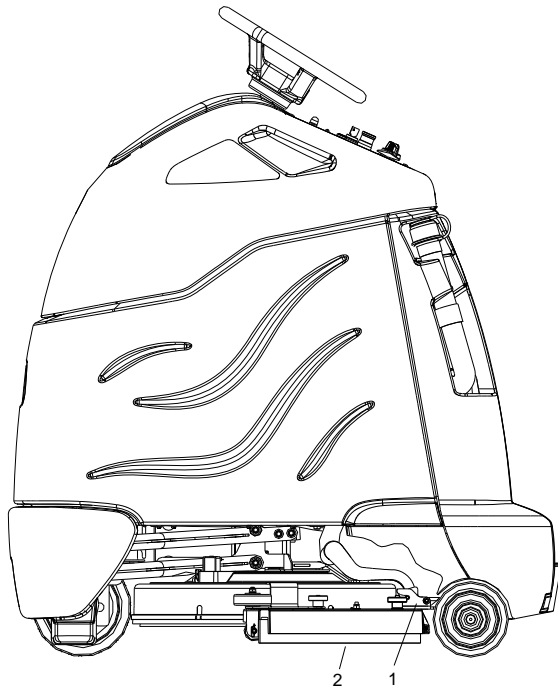

DISK

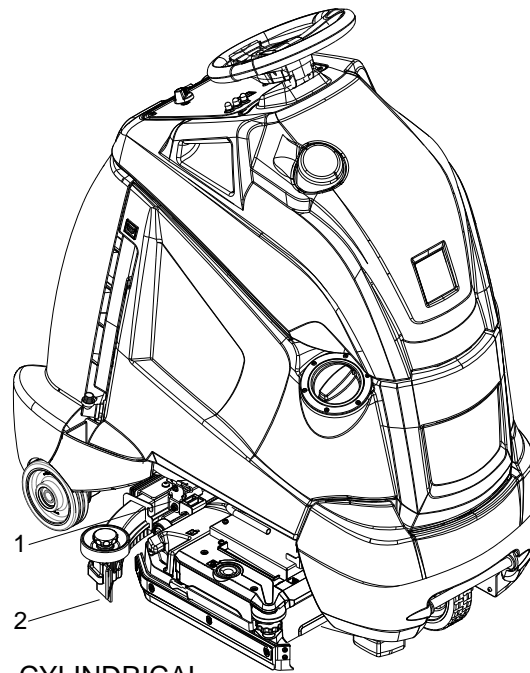

CYLINDRICAL

1. Squeegee Retainer Latch
2. Squeegee

Squeegee Blades - Disk

The front squeegee blade allows solution to pass through channels in the blade into the squeegee assembly while maintaining vacuum to provide lift. The front blade has four wear surfaces and can be rotated for extended life. The front blade should not require regular replacement under normal use.

The rear blade wipes the floor to a near dry condition. It is important the rear blade be in good condition to properly do its job. As with the front, each squeegee blade assembly has four wear surfaces for extended service.

Check both the front and rear squeegee blades for damage and wear each day in the pre-run check. Change the front blade if it is torn or has an uneven edge. Change the rear blade if it is less than half the original thickness.

To Remove Squeegee Assembly

1. With the squeegee in the up position, turn key switch "OFF".
2. Disconnect vacuum hose from squeegee and squeeze the squeegee retaining latch.
3. Pull squeegee assembly from the squeegee arm.
4. Inspect or repair as necessary and reinstall.

To Replace or Rotate Squeegee Blades

1. With the squeegee in the up position, turn key switch "OFF".

FOR SAFETY: Before leaving or servicing machine; stop on level surface, turn off machine and remove key.

2. Remove the squeegee assembly from the machine.
3. Unscrew each of the four (4) knobs until they are nearly removed from the squeegee assembly. Grasp the squeegee assembly and push on the knobs to remove the blade retainer.

Remove the knobs and pull the blade retainer out. Rotate the squeegee blade to new edge position or replace as required. Each blade has four (4) new edge positions.

4. Pull the blades off the retainer.

To reinstall the blades, hook the blades over the pins on the retainer plate.

5. Lower the retainer with blades back in position in the squeegee assembly and install the knobs.

Squeegee Blades-Cylindrical

The front squeegee blade allows solution to pass through channels in the blade into the squeegee assembly while maintaining vacuum to provide lift. The front blade has two (2) wear surfaces and can be rotated for extended life. The front blade should not require regular replacement under normal use.

The rear blade wipes the floor to a near dry condition. It is important the rear blade be in good condition to properly do its job. As with the front, each squeegee blade assembly has two (2) wear surfaces for extended service.

Check both the front and rear squeegee blades for damage and wear each day in the pre-run check. Change the front blade if it is torn or has an uneven edge. Change the rear blade if it is less than half the original thickness.

To Remove Squeegee Assembly

1. With the squeegee in the up position, turn key switch "OFF".
2. Disconnect vacuum hose from squeegee and squeeze the squeegee retaining latch..
3. Pull squeegee assembly from the squeegee arm.
4. Inspect or repair as necessary and reinstall.

To Replace or Rotate Squeegee Blades

1. With the squeegee in the up position, turn key switch "OFF".

FOR SAFETY: Before leaving or servicing machine; stop on level surface, turn off machine and remove key.

2. Remove the squeegee assembly from the machine.
3. Unscrew two yellow thumb screws. Remove bumper wheels and plastic end caps.
4. Slide squeegee blade(s) out the end of the squeegee.
5. Reverse procedure to install new blades.

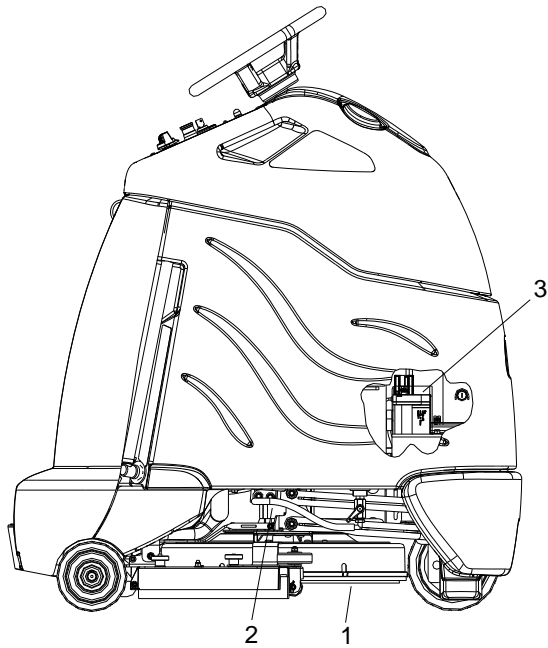

DISK

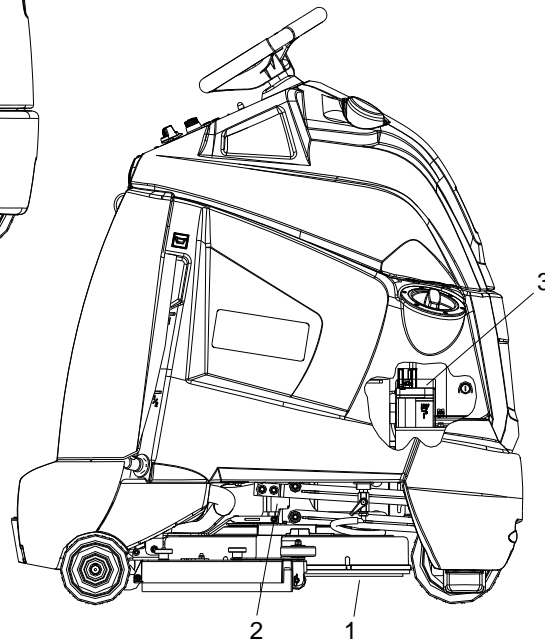

CYLINDRICAL

Scrub Deck-Disk

1. Scrub Deck Side
2. Scrub Brush Motor
3. Scrub Deck Lift Actuator

Scrub Deck-Cylindrical

1. Scrub Deck Side Squeegee
2. Scrub Brush Motor
3. Scrub Deck Lift Actuator

Scrub Brush-Disk

There are different types of brushes available to cover applications from cleaning heavily soiled floors to polishing. A pad driver is also available to take advantage of the many cleaning pads on the market. Please refer to the following to assist in selecting the proper brush or pad for the work at hand.

Finished Floors

Polypropylene is a general-purpose scrub brush with stiff bristles. Polypropylene works well for maintaining routed tile floors.

Nylon bristles are used in a variety of applications on coated or uncoated surfaces.

White Pads (Polishing) are used for dry polishing to achieve a high-gloss appearance, or surface washing on highly polished or burnished floors.

Red Pads (Buffing) are used for light-duty scrubbing. When used with a mild detergent they will provide surface cleaning without removing the finish.

Blue Pads (scrubbing) are used for heavy scrubbing and light top scrubbing. The blue pads remove black marks, stains and dirt. The blue pad may also remove some floor finish.

Black pads (top scrubbing) are used to remove ground in soil and the top layers of floor finish to prepare for recoating.

The scrub brushes should be checked before each days work for wire, string, wear and damage.

Scrub Brush-Cylindrical

There are different types of brushes available to cover applications from cleaning heavily soiled floors to polishing.

White (Soft)

Orange (Hi/Lo)

Red (Medium)

Green (Hard)

Replacing or Installing Scrub Brushes (Disk)

FOR SAFETY: Before leaving or servicing the machine; stop on level surface, turn OFF machine and remove key.

1. Turn machine power off.
2. Open access cover on deck shroud.
3. Locate release lever, press release lever towards front of machine to release brush pad. The pad will drop down when released. Lift deck shroud up and slide brush/pad assembly out.



4. Remove brush/pad from holder and replace with new brush/pad.
5. To reinstall, lift deck shroud upward as shown.

Center the brush/pad driver under the brush drive hub.

Raise brush/pad until it contacts brush driver assembly. Turn clockwise until release lever plate locks into position.



6. Check that release lever/plate is completely closed and pad/brush is securely attached.

NOTE: Damage to driver or brush could occur if not securely attached.

Replacing or Installing Scrub Brushes (Cylindrical)

FOR SAFETY: Before leaving or servicing the machine; stop on level surface, turn OFF machine and remove key.

1. Turn machine power off.
2. From right side of machine, lift squeegee latch and swing side squeegee outward to access brushes.

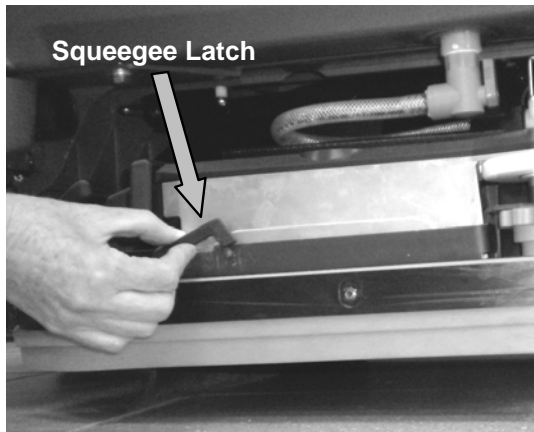

3. Press brush release. Brushes will drop downward. Remove old brushes.

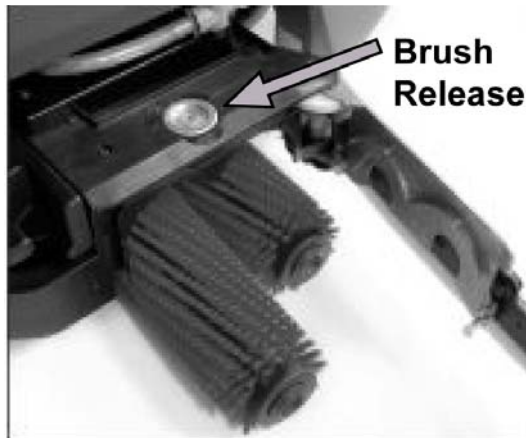

4. Slide new brushes into receptacle at far side of deck, lift upward and snap into position. Ensure brushes are secure.



5. Close side squeegee and latch securely.

⚠ WARNING:

Do not use a pressure washer to clean around the brush motors. Use tap pressure only.

⚠ AVERTISSEMENT:

N'utilisez pas de nettoyeur haute pression pour nettoyer autour des moteurs des brosses. Utilisez seulement la pression du robinet.

To Replace Scrub Brush Motor - Disk

With the scrub deck in the lowered position, disconnect brush motor wiring connector from harness.

1. Disconnect the two(2) connectors from solenoid valve.
2. Remove squeegee.
3. Remove front bumper.
4. Remove four (4) front bolts connecting deck lifting arms to front of machine.
5. Lift deck and side deck lift brackets off actuator lifting pin.
6. Slide deck out from under machine on right side, orientation is determined from operators view.
7. Remove brush/pad.
8. Remove driver.
9. Remove three (3) screws securing brush motor to deck.
10. Remove brush motor.
11. Reverse steps to install

⚠ WARNING:

Do not use a pressure washer to clean around the brush motors. Use tap pressure only.

⚠ AVERTISSEMENT:

N'utilisez pas de nettoyeur haute pression pour nettoyer autour des moteurs des brosses. Utilisez seulement la pression du robinet.

To Replace Scrub Brush Motor-Cylindrical

1. Lower scrub deck using selector knob. Turn off key in down position.
2. Disconnect the two connectors from solenoid valve.
3. Remove squeegee assembly.
4. Remove front bumper, 2 bolts.
5. Remove four front bolts connecting deck lifting arms to front of machine.
6. Remove actuator lifting pin and washers.
7. Remove solenoid valve and cover, 2 screws.
8. Disconnect motor plug from harness.
9. Slide deck out from under machine on right side, orientation is determined from operators view.
10. Remove metal cover over motor by removing 10 screws mounting to deck.
11. Remove screws mounting motor to drive housing and remove motor.
12. Reverse steps to install.

Scrub Deck Actuator Removal / Replacement

FOR SAFETY: Before leaving or servicing machine, stop on a level surface. Turn off machine.

1. Support deck under pad driver so that actuator pins can be removed.
2. Remove bumper screws (2).
3. Remove front battery.
4. Pull steering shaft.
5. Disconnect actuator from wiring harness.
6. From the underside of the machine, remove lower lifting pin from actuator.
7. Remove clevis pin from actuator upper bracket.
8. Lift actuator upward and free from machine.
9. Reverse steps to install.

Circuit Protection

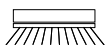
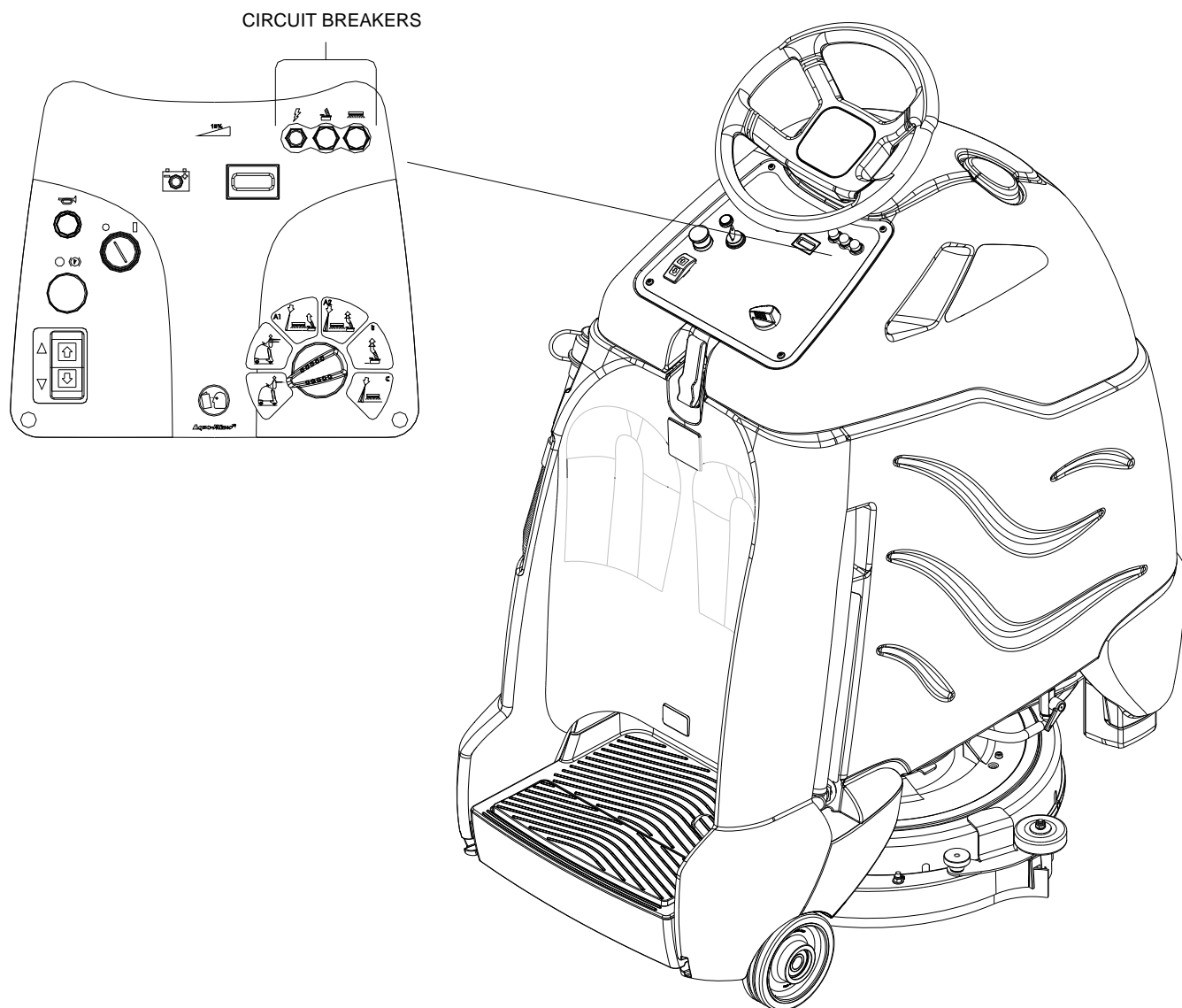

Circuit Breakers

Circuit breakers interrupt the flow of power in the event of an electrical overload. When a circuit breaker is tripped, reset it by pressing the exposed button. If a circuit breaker continues to trip, the cause of the electrical overload should be found and corrected.

1.5 Amp protects the brush deck lift actuator, horn & controller.

Solution

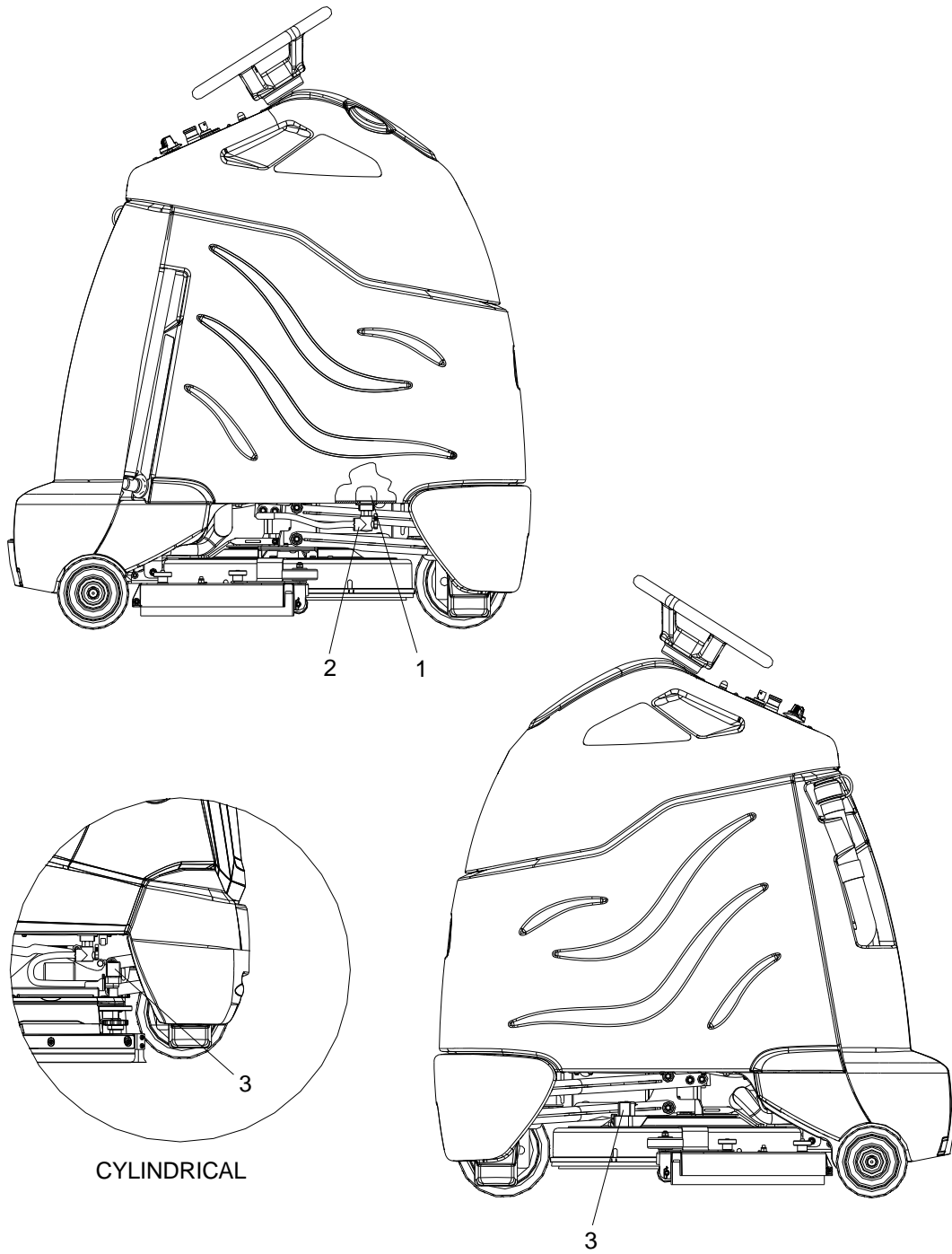

1. Solution Strainer-Coarse

2. Shut-off Valve

3. Solenoid Valve

1. SOLUTION STRAINER

Located in bottom of tank. The strainer protects the ball valve and solenoid valve from debris. If the ball valve and solenoid valve are not working, then check the strainer for debris.

Drain the solution tank.

Reach down to the strainer and remove debris. If the strainer can not be cleaned in place remove strainer.

To remove the strainer, rotate the strainer counterclockwise.

Clean out the debris from wire mesh and re-assemble

2. SHUT-OFF FLOW VALVE

Prior to Serial Number *(6):

Located below the solution tank on the right side. If no flow, check lever position.

Horizontal is half flow.

Down is maximum flow.

Up is no Flow.

If clogged, in the maximum position, unscrew fittings, inspect and clean if needed.

From Serial Number *(6):

Located below the solution tank on the right side. If no flow, check lever position.

Horizontal is no flow.

Up is maximum flow.

If clogged, in the maximum position, unscrew fittings, inspect and clean if needed.

3. SOLENOID VALVE

The solenoid valve shuts off solution flow to scrub deck whenever scrubbing stops.

The solenoid valve is mounted on the front of the scrub deck, on left side.

Shut off manual water supply valve on right side of machine.

Disconnect the two (2) spade connections.

The solenoid valve snaps into place, rock the solenoid valve back and forth while lifting to free it.

Remove valve from supply hose.

*See Serial Number Page.

Tank Assembly Removal

In order to access the frame or drive components, the entire tank/console cover assembly can be removed as a single unit.

Tank Removal:

1. Open the console cover.
2. Tilt the recovery tank back until it stops on the lanyard.
3. Remove the recovery tank vacuum hose from its connection at the rear cross member.
4. Tilt the recover tank slightly forward and disconnect the lanyard. Lean the recovery tank back until it contacts the floor. Lift the tank and back panel from the hinge pin and set aside.
5. Disconnect the squeegee vacuum hose from the connection at the rear cross member.
6. Grasp the lower end of the flexible steering shaft and pull it straight up until it is disengaged with the hex steering shaft. Place the loose end into one of the fill ports.
7. Remove the cover and gasket at the steering shaft area.
8. Disconnect four electrical plugs from the limit switches located between the steering shaft and the actuator. Do not pull on the wires to disconnect the plugs.
9. Disconnect the five electrical plugs located just forward of the battery tray. To disconnect, lift the plugs off of their mounting plate, locate and depress the lock tab and pull the connectors apart. Replace the lower half of the connectors on to the support plate after the tank assembly has been removed.
10. Remove the battery cable connection from the rear cross member.
11. Close the console cover.
12. Locate the solution solenoid valve on the left side of the scrub deck. Remove two electrical wires from the valve. The wires are interchangeable. Lift the valve out of its mount pocket and move the valve and connected hose over to the right side of the machine. It is not necessary to remove the valve or hose from the solution tank.
13. Remove the bumper. One mounting bolt per side is located just above the tip pads on the inside.
14. Remove 5 bolts holding the tank in place.
15. The tank assembly can now be lifted off the chassis and set aside.
16. Support the tank assembly so that the weight of it is not resting on the solution valve plumbing.
17. The lower half of the electrical connectors can now be easily placed on to their support plate.
18. Reverse the process for reassembly. Refer to the electrical diagrams for connection of the four limit switches. Use care not to bend the switch tabs.

Drive Unit Removal

1. Remove tank assembly.
2. Pull the brake and drive electrical connectors off of their support plate.
3. Remove the P-clamp holding the cable.
4. Lift the chain cover plate off of the motor.
5. Support the chassis on the tip pads so that the front wheel is 10 inches off the floor.
6. Locate and remove two mounting nuts and remove the drive unit from below.
7. To reinstall, reverse the process.
8. Note the small tab at the front of the drive unit frame should line-up with the notch in the mating plate.

Vacuum & Float Shutoff

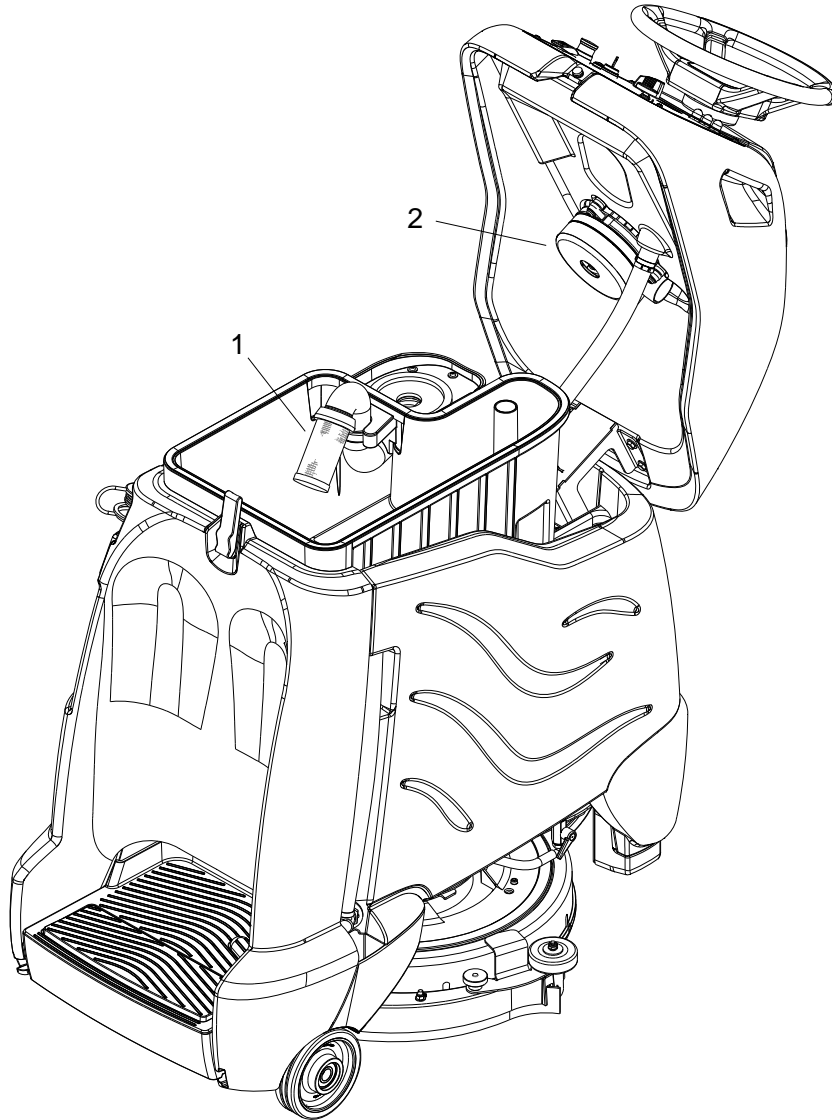

1. Recovery Tank Float Shut-off

2. Vacuum Motor

Recovery Tank Float Shut-off

When water is no longer being vacuumed from the floor and the vacuum fan is operating, the ball float has engaged. The vacuum motor will not vacuum water with recovery tank full. The recovery tank must be drained.

1. The float shut-off screen can be cleaned in or out of the machine.
2. To clean the float shut-off while it is inside the machine wipe material off screen then rinse. Check that the ball is also clean and moves freely.
3. To remove the float shut-off, grasp the screen with one hand and the connected tube with the other. Tilt and pull the float screen assembly to pull it off the barb on the tube.
4. To install, place one hand on the tube, and then tilt and push the float screen assembly over the barb on the tube.

Vacuum Motor Carbon Brush Replacement

Vacuum Motor Carbon Brushes

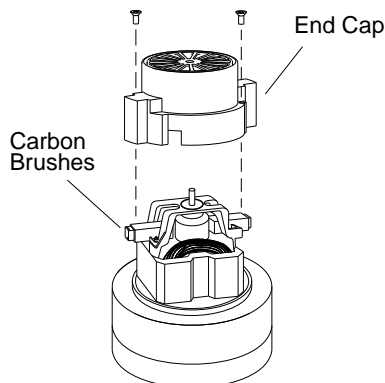

If armature commutator is grooved, extremely pitted or not concentric, the motor will need to be replaced or sent to a qualified service center.

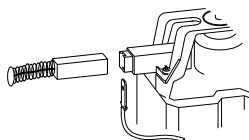

Important:

These brushes wear quicker as the length shortens due to increased heat. Spring inside brush housing will damage motor if brushes are allowed to wear away completely.

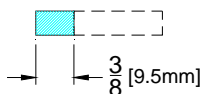

Periodically check the length of the carbon brushes. Replace both carbon brushes when either is less than 3/8" (9.5mm) long.

FOR SAFETY: before leaving or servicing machine, stop on a level surface, turn off machine and disconnect power.

To Repair or Replace Vacuum Motor

1. Remove four (4) screws from top of control panel.
2. Tip control panel back from console to expose vacuum motor wires.
3. Disconnect electrical connector from the vacuum motor.
4. Replace control panel, attach with one (1) screw to secure in place.
5. Open console.
6. Remove three (3) screws that secure vacuum motor.
7. Reverse steps to install.

MOUNT .80" FROM SEALING SURFACE OF CONSOLE TO THE TOP OF THE MOUNTING TABS (3).

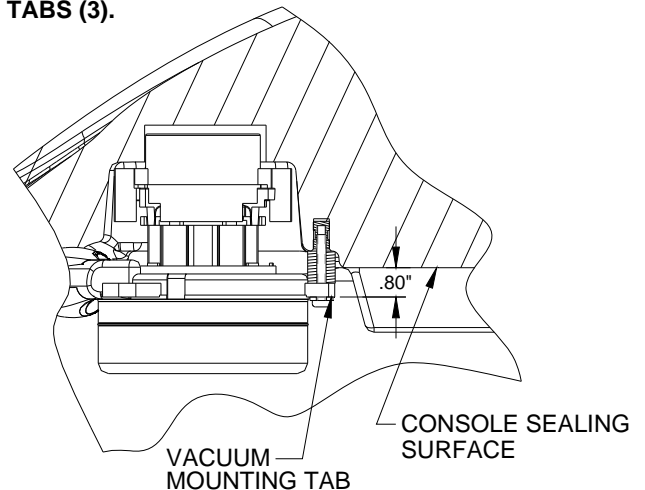

NOTE: If vacuum motor is not mounted as shown, vacuum may not seal properly, resulting in poor performance.

Drive Motor

Drive Motor Carbon Brush Replacement

⚠ WARNING:

Do not use a pressure washer to clean around the motors. Use tap pressure only.

⚠ AVERTISSEMENT:

N'utilisez pas de nettoyeur haute pression pour nettoyer autour des moteurs des brosses. Utilisez seulement la pression du robinet.

FOR SAFETY: Before leaving or servicing machine, stop on a level surface, turn off machine and remove motor carbon brushes.

1. Open the console cover.
2. Tilt the recovery tank back until it stops on the lanyard.
3. Grasp the lower end of the flexible steering shaft and pull it straight up until it is disengaged with the hex steering shaft. Place the loose end into one of the fill ports.
4. Remove the cover and gasket at the steering shaft area.
5. Grasp the drive wheel by reaching under the front bumper and turn it to near the left steering stop.
6. The drive motor carbon brushes are located under screw caps. The caps are accessible by gently moving the harness aside.
7. Rotate the drive wheel to near the right hand stop to access the right side carbon brush.
8. Replace the gasket and cover, set the drive wheel straight ahead, set the steering wheel straight ahead, and gently align the steering shaft coupling and slide onto the lower shaft.
9. Slowly close the cover and make sure the shaft slides without binding.

Drive Chain Tension

The drive chain should deflect about 1/4 inch on either side of the loop when the opposite side is tight.

To adjust chain tension:

1. Remove bumper.
2. Loosen five (5) screws that hold the drive gear motor and slide the gear motor up until the chain tension is correct. Tighten the five (5) mounting screws.
3. Models equipped with jack screw on front side of drive should not use jack screw to apply tension. Use only as a stop once chain is properly tensioned.
4. Reinstall the bumper.

Transporting Machine

This machine is equipped with a drive gear engagement/disengagement lever.

The brake automatically engages and keeps the machine from moving whenever the operator stops the machine.

The drive gear can be disengaged so the machine can be pushed or towed (slowly).

When the drive gear is disengaged the machine cannot be driven.

NOTE: Front bumper removed for clarity and to show access to lever.

Lever access

Turn wheel to left and reach up under bumper and steel bracket.

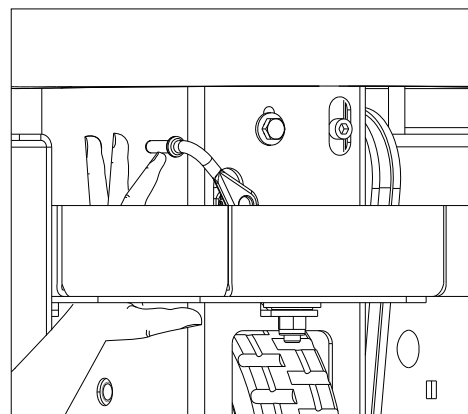

Drive gear engaged

Machine can be driven.

Rotate lever firmly in direction of arrow.

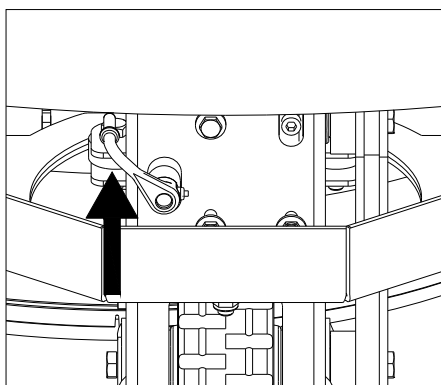
**Inclines**

When navigating an incline the machine may come to a stop. Turn the machine off. Wait 5 minutes and start the machine and proceed up the incline.

⚠ CAUTION:

Overheating may occur if you do not wait the full 5 minutes.

⚠ ATTENTION:

Une surchauffe peut se produire si vous n'attendez pas les 5 minutes complètes.

Drive gear disengaged

Machine can be pushed or towed (slowly).

When disengaged the machine rolls easily. Disengage on a level surface.

Rotate lever firmly in direction of arrow.

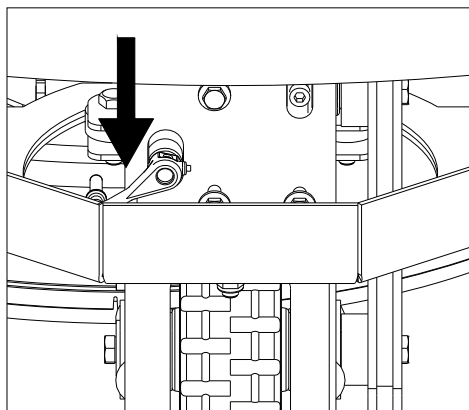

Preparation for Loading/Unloading Trailer

Before loading or unloading machine from trailer, remove squeegee and scrub brush (pad) to eliminate interference with ramp.

Scrub head must be in the up position before loading.

When transporting the machine on a trailer or in a truck, in addition to using tie-downs, be sure to block the tires to prevent the machine from rolling.

Machine Tie-Downs

There are two tie points located in front of the rear wheels on the frame, and a Tie-down wrap point on the recovery tank. Tie-down devices must be of the proper type and strength. The combined strength of all tie-downs must be strong enough to lift two times the weight of the machine. Tie-downs must be positioned to prevent the machine from moving forward, backward, or either side to side. Use all four corners of the machine with the tie-downs running out opposite directions. Tie-downs must be attached to the transporting vehicle securely.

Recommended Tie-Down Points

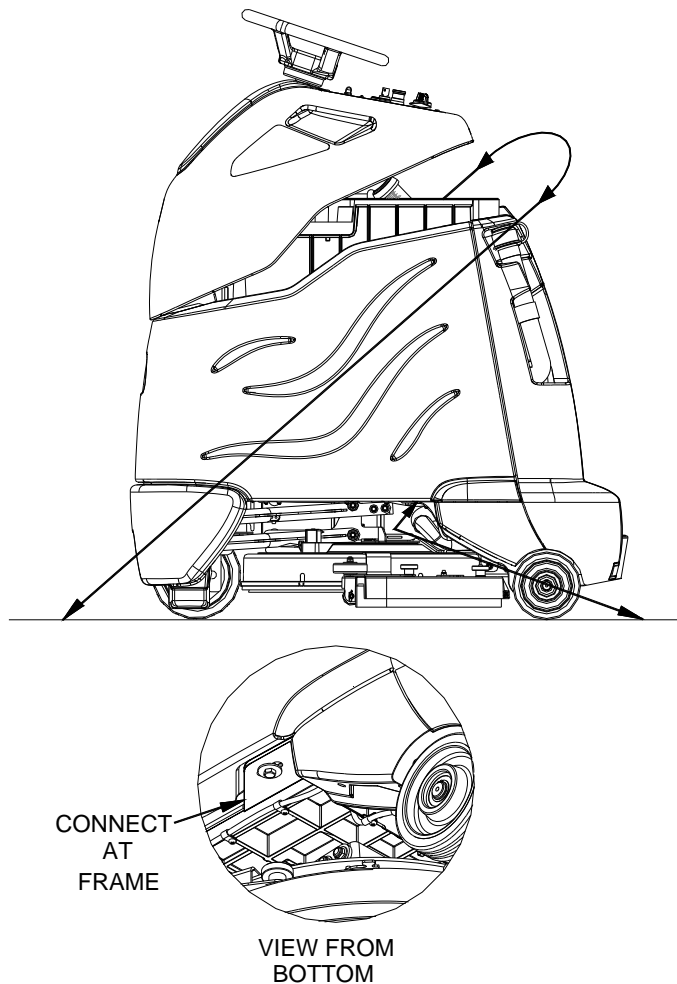

Machine Tie-Downs (Deluxe)

There are two tie points located in front of the rear wheels on the frame, one on the front bumper tie-down bar, and a Tie-down wrap point on the recovery tank. Tie-down devices must be of the proper type and strength. The combined strength of all tie-downs must be strong enough to lift two times the weight of the machine. Tie-downs must be positioned to prevent the machine from moving forward, backward, or either side to side. Use all four corners of the machine with the tie-downs running out opposite directions. Tie-downs must be attached to the transporting vehicle securely.

Recommended Tie-Down Points

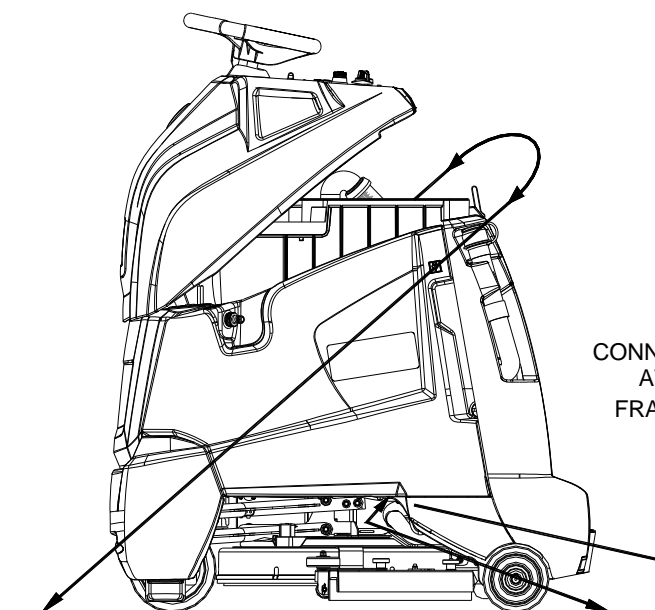

Troubleshooting

PROBLEM	CAUSE	SOLUTION
No machine function	Console lid is open	Close console lid
No power to machine	Battery disconnected	Check all battery cable connections
	Emergency shut-off activated	Reset
	Battery cables corroded	Clean connections
	Faulty key switch	Replace switch
	Batteries not plugged in	Plug batteries in
	On Board charger plugged in	Un-plug and stow cord
Little or no propel	Low battery charge	Charge batteries
	Tripped circuit breaker	Reset controller circuit breaker
	Controller protecting motor from overload	Controller limits motor amperage. Allow unit to cool down for several minutes.
	Machine is stalled against an obstacle (threshold, curb, etc.)	Remove obstacle or push machine away from obstacle
	Controller overheated	Allow cool down period
	Loose motor connection	Check wires and connections from controller to motor
	Faulty throttle circuit or potentiometer	Check wires and connections from and potentiometer resistance
	Drive Lever disengaged	Engage drive
Machine does not change speeds	Faulty speed control circuit or switch	Check wires & connections
Forward speed only	Faulty forward/reverse circuit	Check wires & connections
Reverse speed only		
Poor or no water pickup	Debris caught on squeegee	Remove debris
	Worn squeegee blades	Rotate or replace squeegee blades
	Vacuum hose clogged	Clear obstruction from hose
	Vacuum hose disconnected from squeegee or recovery tank	Reconnect vacuum hose
	Recovery tank float system dirty	Clean float system
	Recovery tank not sealed	Latch console cover Check or replace damaged gasket
	Vacuum circuit breaker tripped	Reset circuit breaker
	Float-ball shut-off engaged tank full	Empty recovery tank
	Foam filling recovery tank	Empty recovery tank. Use less or different detergent. Use defoamer
	Battery indicator light flashing	Battery needs charged
Controller is indicating a fault code		See fault code table

PROBLEM	CAUSE	SOLUTION
Vacuum motor does not run, or runs slowly	Faulty vacuum circuit or switch	Check wires & connections
	Worn vacuum motor brushes	Replace brushes, check commutator
	Vacuum circuit breaker tripped	Reset circuit breaker
Poor scrubbing performance	Debris caught in scrub brush	Remove debris
	Worn brush or pad	Replace brushes or pads
	Improper detergent, brush or pad used	Contact equipment or application specialists
	Low battery charge	Charge batteries
Little or no solution flow to the floor	Solution tank empty	Fill solution tank
	Solution strainer plugged	Clean solution strainer
	Solution system plumbing obstructed	Clear obstruction from plumbing
	Solution solenoid valve obstructed or stuck	Solution solenoid valve obstructed or stuck
	Solution metering valve is closed	Open metering valve
	Faulty solenoid	Check solenoid valve
	Faulty limit switches or connection	Check limit switches and connections
Brush motor does not run, or runs slowly	Circuit breaker tripped	Reset circuit breaker
	Low battery charge	Charge battery
	Faulty brush circuit or motor	Check wires, connections and motor
	Worn brush motor brushes	Replace brushes, check commutator
	Faulty limit switches or connection	Check limit switches and connections
Squeegee won't go down	Squeegee in double scrub mode	Release squeegee from double scrub mode
Deck won't go down	Actuator circuit breaker tripped	Reset actuator circuit breaker

Battery Discharge Indicator Troubleshooting

The battery indicator flashes when a problem occurs. The table below list solutions for the indicated problems.

Number of flashes	Problem	Solution
1	The battery needs charging, there is a bad connection to the battery or dependent on the programming, may indicate that the battery lockout function is active and the controller is in a restricted mode of operation. Check the connections to the battery.	If the connections are good, try charging the battery.
2	There is a bad connection to the drive motor.	Check all connections between the motor and the controller.
3	The drive motor has a short circuit to a battery connection.	Contact your service agent.
4	The battery charge level has fallen below the battery Lockout Level and the controller is inhibiting scrub motor function.	Charge the battery.
5	Not used.	-
6	The controller is being inhibited from driving, this may be because the battery charger is connected (on board charger only).	Disconnect battery charger.
7	A throttle fault is indicated.	Make sure that the throttle is in the rest position before switching on the machine.
8	A controller fault is indicated.	Make sure that all connections are secure.
9	The parking brake has a bad connection.	Check the parking brake and motor connections. Make sure the controller connections are secure.
10	An excessive voltage has been applied to the controller. This is usually caused by a poor battery connection.	Check the battery connections.
-	Blinks once every 5 seconds	Sleep mode, cycle key switch

Parts

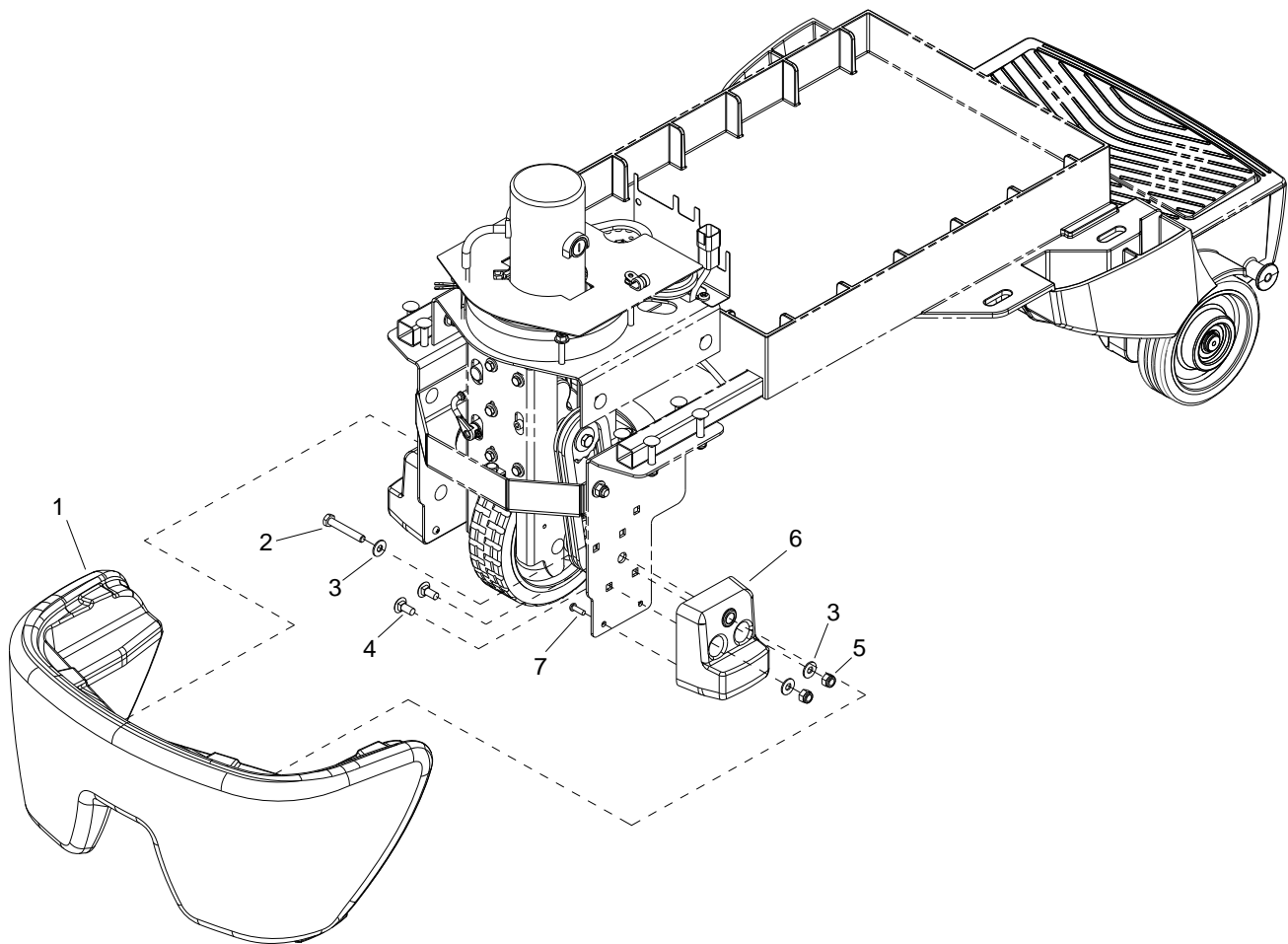

REF	PART NO.	QTY	DESCRIPTION	SERIAL NO. FROM	NOTES
1	86318180	1	BUMPER, TRIM, GRAY		
2	86276980	2	SCREW 5/16-18 X 2 HHCS SS		
3	86010670	6	WASHER 5/16 FLAT SS		
4	86276070	4	SCR, 5/16-18 X 3/4 CARRIAGE SS		
5	86270830	4	NUT 5/16-18 HEX NYLOCK SS		
6	86323950	2	PAD, TIP		
7	86327510	4	SCR, KA50X16, PT OHS, WN1412, A2 SS		

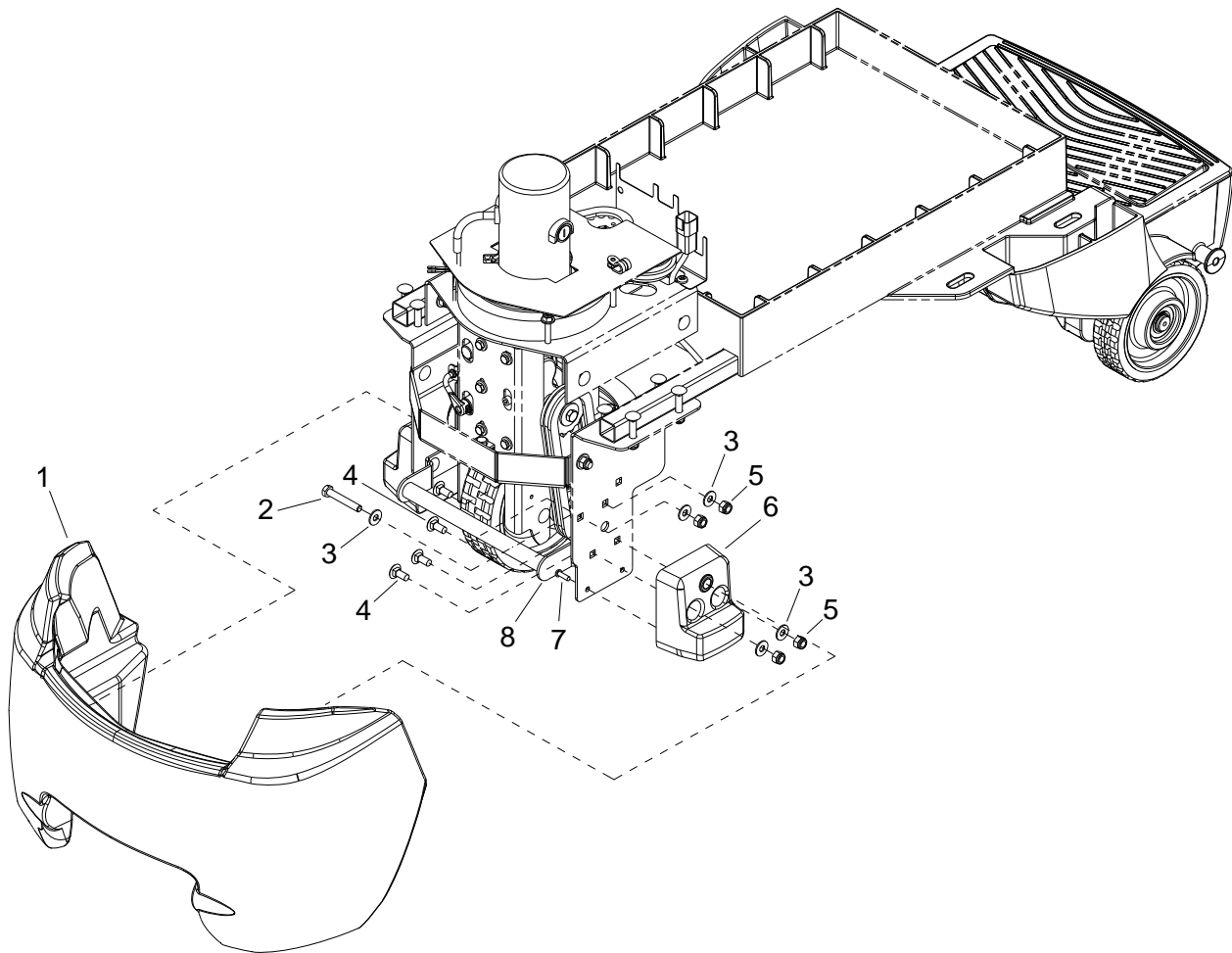

REF	PART NO.	QTY	DESCRIPTION	SERIAL NO. FROM	NOTES
1	86342940	1	BUMPER, TRIM, CSX20		
2	86276980	2	SCREW 5/16-18 X 2 HHCS SS		
3	86010670	10	WASHER 5/16 FLAT SS		
4	86276070	8	SCR, 5/16-18 X 3/4 CARRIAGE SS		
5	86270830	8	NUT 5/16-18 HEX NYLOCK SS		
6	86323950	2	PAD, TIP		
7	86327510	4	SCR, KA50X16, PT OHS, WN1412, A2 SS		
8	86333910	1	BRACKET, TIE DOWN		

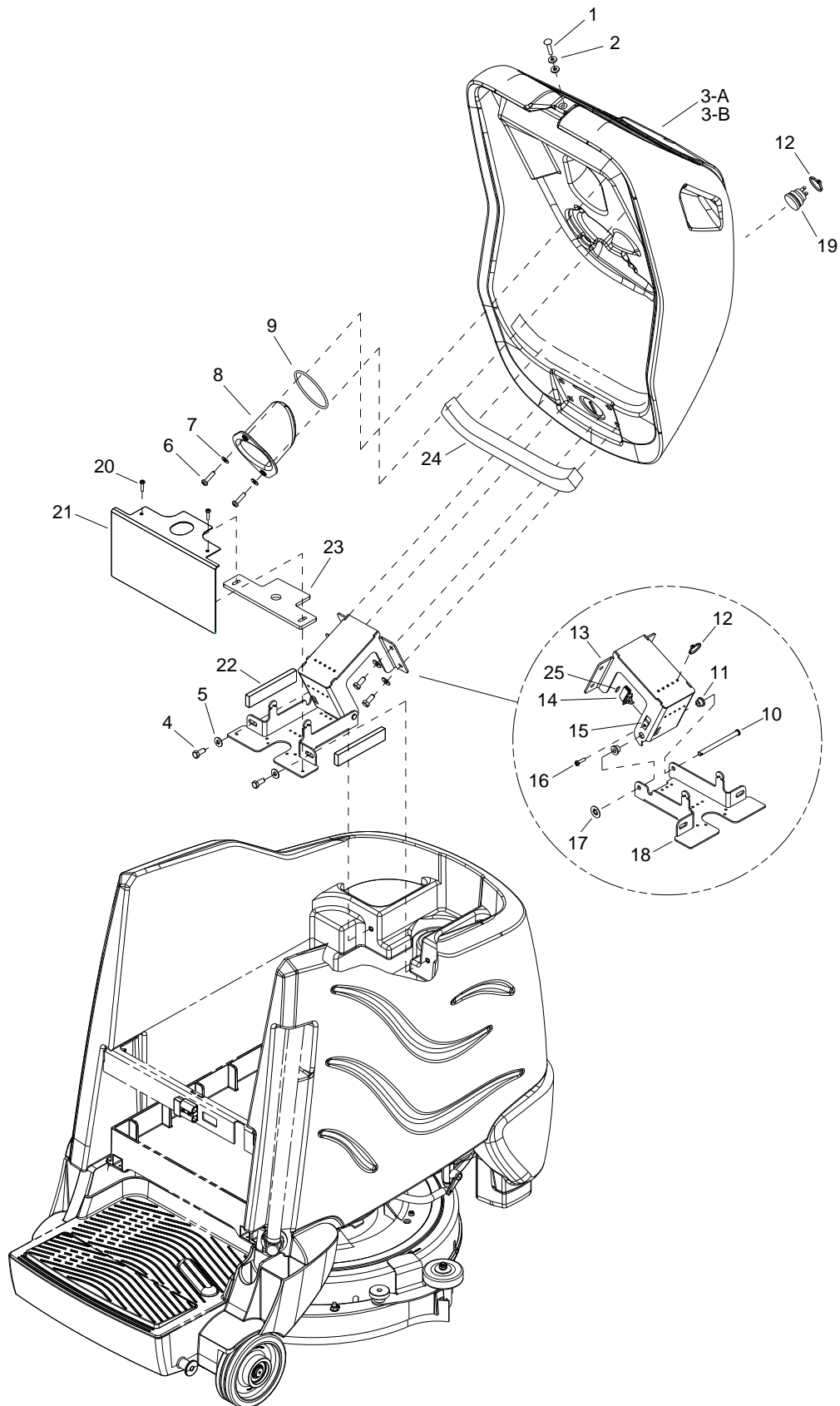

REF	PART NO.	QTY	DESCRIPTION	SERIAL NO. FROM	NOTES
1	86276330	1	SCR, 1/4-20 X 1.25 CARRIAGE BZ		
2	86279520	2	WASHER, 1/4 ID FLAT BLK		
3A	86317960	1	CONSOLE, CS20		DISK
3B	86342490	1	CONSOLE, CSX20		DELUXE & CYLINDRICAL
4	86276780	6	SCR, 5/16-18 X 3/4 HHCS SS		
5	86010670	6	WASHER, 5/16 FLAT SS		
6	86006530	2	SCREW 1/4-20 X 1 PPHMS SS		
7	86010630	2	WASHER 1/4 ID X 5/8 OD SS		
8	86317980	1	DOME		
9	86327600	1	GASKET, DOME		
10	86326340	1	PIN, CLEVIS 5/16 X 4.0, PLTD		
11	86228990	2	BEARING, FLNGD, .314ID X .502OD		
12	86264940	6	CABLE TIE, 11.38" UL/CSA		
13	86326320	1	BRACKET, HINGE UPPER		
14	86327680	1	SWITCH, INTERLOCK		
15	86270860	1	NUT, 10-24 U-TYPE SPEED		
16	86277110	1	SCR, 10-24 X 3/4 PPHMS SS		
17	86328860	1	NUT, 5/16 PUSH-LOCK, PLTD		
18	86326330	1	BRACKET, HINGE LOWER		
19	86239720	1	SP HORN, 108DB MINATURE W/RING		
20	86006800	2	SCREW 10-32 X 1/2 PHTR PLT		
21	86332390	1	PLATE, COVER		
22	86332770	2	GASKET, HINGE BRACKET		
23	86332760	1	GASKET, STEERING SHAFT		
24	86302620	1	FOAM, 1 X 1 X 20		DELUXE ONLY
25	86402180	1	GASKET, .125 X .375 X .65		

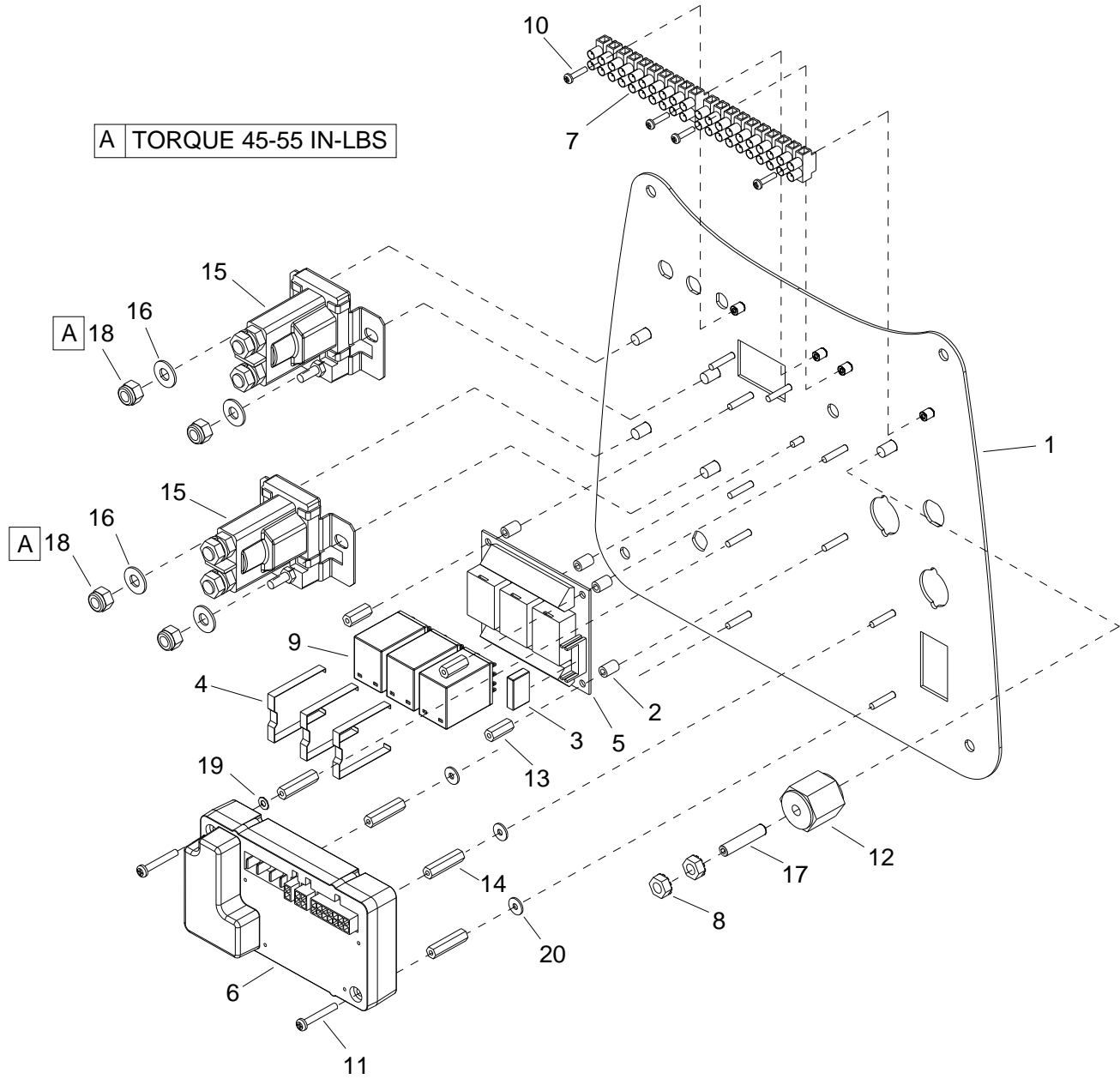

REF	PART NO.	QTY	DESCRIPTION	SERIAL NO. FROM	NOTES
1	86339950	1	PANEL, CONTROL		
2	86337210	5	SPACER, .14ID X .25OD X .38, NYL		
3	86336110	1	RELAY, SPST-NO		
4	86336100	3	CLIP, RELAY		
5	86336090	1	CIRCUIT BOARD, 4 RELAY		
6	86353610	1	CONTROLLER, CS20	(9*)	
7	86326390	2	CONN, 8MM PITCH, 10 POSN		
8	86005710	2	NUT, 1/4-20 HEX W/STAR		
9	86313900	3	RELAY, 5A, 24V, 4PDT		
10	86275260	4	SCR, 4-40 X 1/2 PPHMS		
11	86274710	2	SCR, 6-32 X 1.0 PPHMS		
12	86255910	1	STANDOFF, 1/4-20 X 1.0 HEX INS		
13	86255900	2	STANDOFF, 6-32 X 5/8 HEX NYL		
14	86255890	4	STANDOFF, 1.0 L. 6-32		
15	86251360	2	RELAY, 36VDC, 100A		
16	86010630	4	WASHER, 1/4 X 5/8 FLAT SS		
17	86006850	1	SCR, 1/4-20 X 1.25 SSSCU		
18	86005810	4	NUT, 1/4-20 HEX NYLOCK SS		
19	86279020	1	WASHER #6 LOCK EXT STAR SS		
20	86279450	3	WASHER, #6 FLAT SAE PLTD		

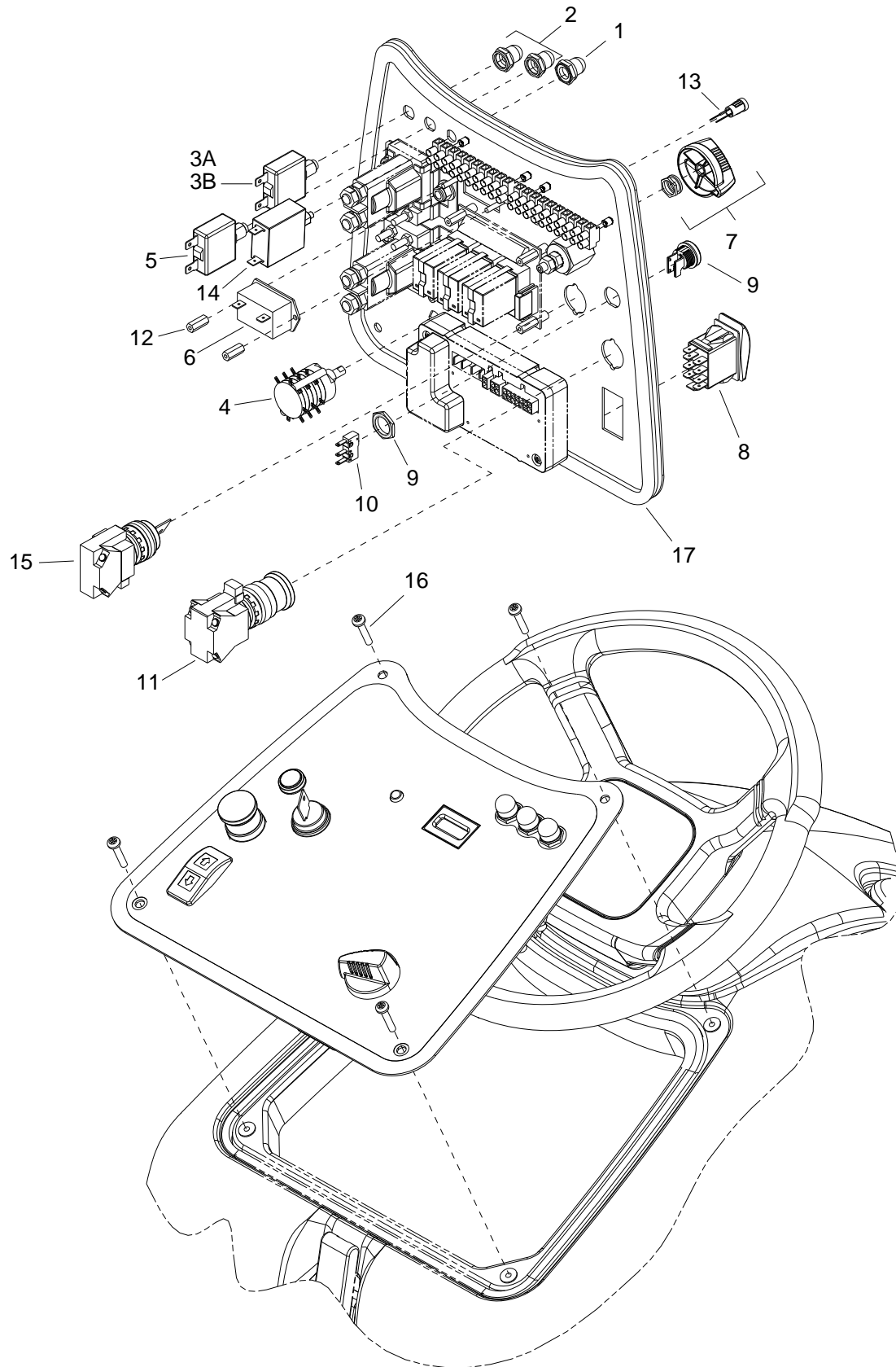

REF	PART NO.	QTY	DESCRIPTION	SERIAL NO. FROM	NOTES
1	86001260	1	BOOT, CB 3/8-32 UNS	(7*)	
2	86332510	2	BOOT, SEAL PUSH BUTTON 11MM		
3A	86328180	1	BREAKER, 12A, 250VAC, 32VDC		DISK
3B	86349290	1	BREAKER, 25A, 250VAC, 32VDC		CYLINDRICAL
4	86326350	1	KIT, CS20 ROTARY SWITCH		***
5	86316160	1	BREAKER, 18A, 250VAC, 32VDC		
6	86315470	1	METER, HOUR, LCD		
7	86314150	1	KNOB, SELECTOR		
8	86313950	1	SWITCH, SPDT 3 POSN MOM, ARROW		
9	86295200	1	ASM, BUTTON, BLACK, W/BEZEL		
10	86292780	1	SWITCH,MICRO		
11	86292590	1	SWITCH, E-STOP AKW CHARIOT		
12	86255900	2	STANDOFF, 6-32 X 5/8 HEX NYL		
13	86348960	1	LED, BATTERY INDICATOR		***
14	86353680	1	BREAKER, 1.5A CARLING MAGNETIC	(7*)	
15	86007170	1	SWITCH, KEY 2 POSITION		
16	86329570	4	SCR, 10-32 X 1.0 TORX SS BLK PLTD		
17	86327830	1	GASKET, .188 X.31 X 41.0		

***86348960 AND ROTARY SWITCH ARE INCLUDED WITH CONTROL PANEL HARNESS, **86326350** IS FOR REPLACEMENT OF THE ROTARY SWITCH WITHOUT HARNESS.

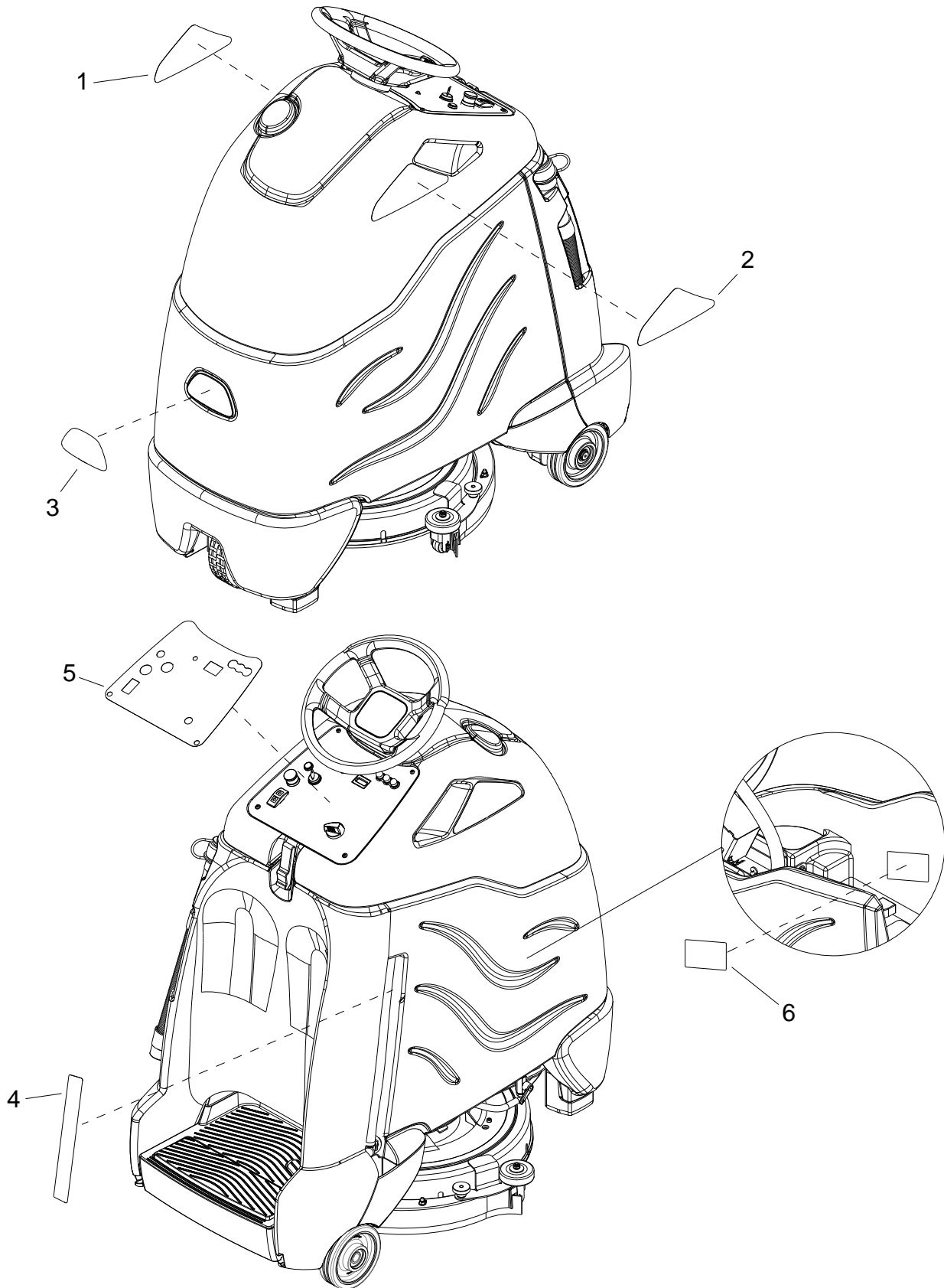

REF	PART NO.	QTY	DESCRIPTION	SERIAL NO. FROM	NOTES
1	86328490	1	LABEL, RIGHT, iSCRUB 20		
2	86328500	1	LABEL, LEFT, iSCRUB 20		
3	86004970	1	LABEL WINDSOR LOGO DOMED		
4	86328550	1	LABEL, SOLUTION LEVEL		
5	86326360	1	LABEL, CONTROL PANEL		
6	86335710	1	LABEL, BATTERY WIRING		

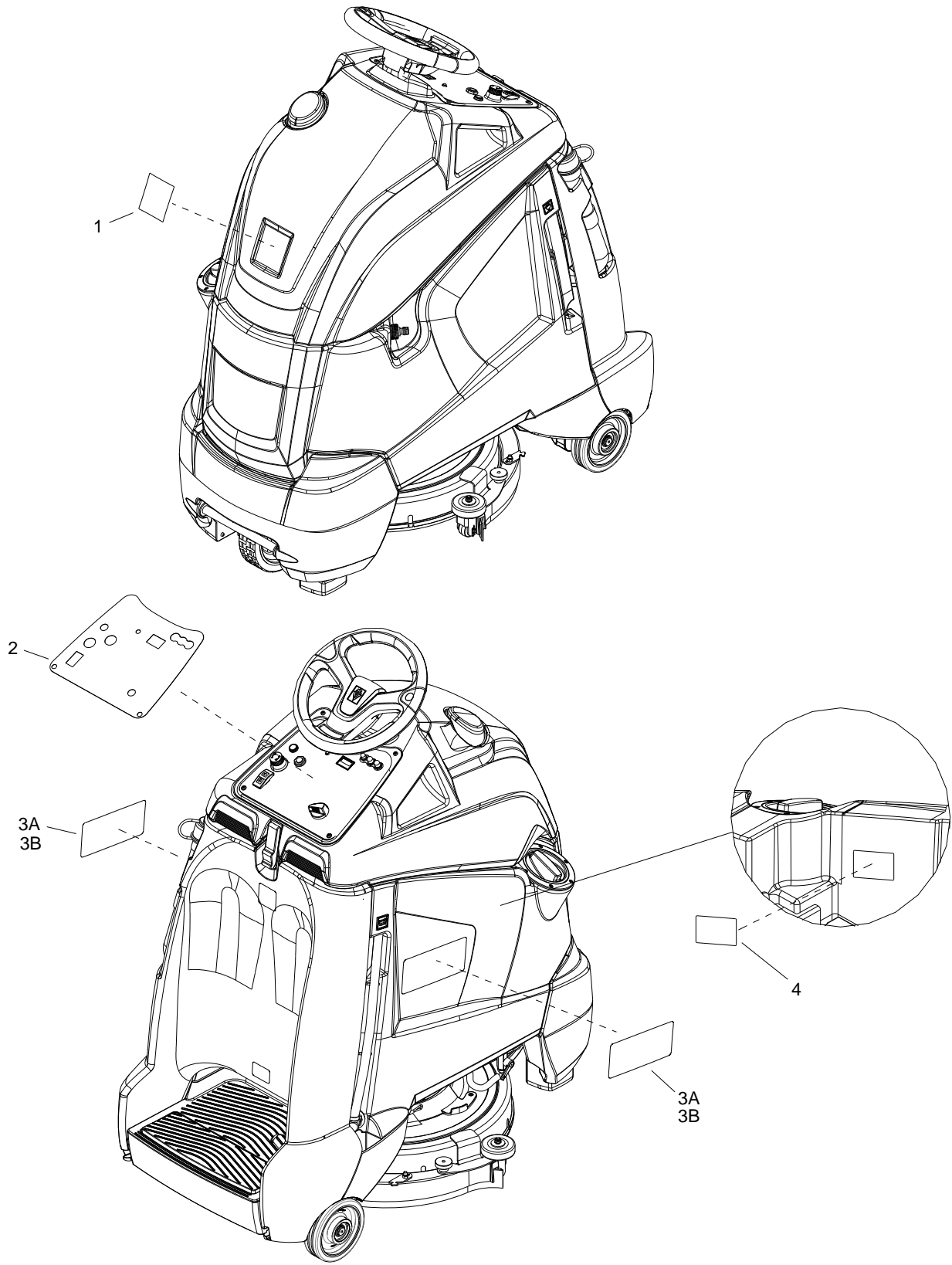

REF	PART NO.	QTY	DESCRIPTION	SERIAL NO. FROM	NOTES
1	86342020	1	LABEL, WINDOSR DOMED LOGO		
2	86326360	1	LABEL, CONTROL PANEL		
3A	86342000	2	LABEL, SIDE ISCRUB DLX		DISK
3B	86346630	2	LABEL, ISCRUB 22X SP		CYLINDRICAL
4	86335710	1	LABEL, BATTERY WIRING		

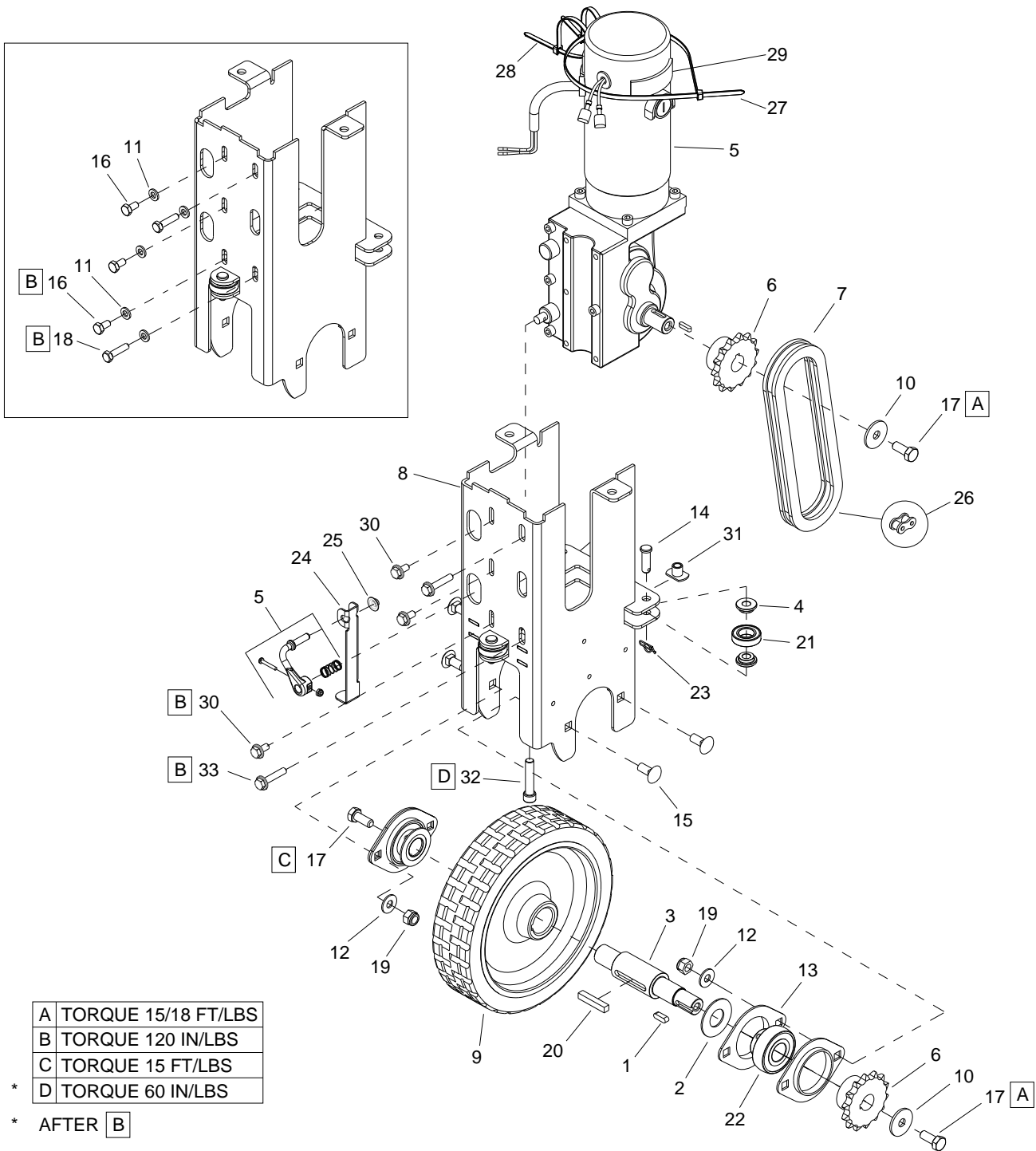

REF	PART NO.	QTY	DESCRIPTION	SERIAL NO. FROM	NOTES
1	86326710	1	KEY, 5 X 5 X 16		
2	86321670	2	WASHER, WHEEL SPACER		
3	86319810	1	AXLE, DRIVE WHEEL		
4	86319670	6	SLEEVE, BEARING		
5	86363090	1	MOTOR, DRIVE WHEEL	(12*)	
-	86331990	-	BRUSH SET, 8.631-966.0 DRIVE MTR		
-	98408960	-	BRAKE REPLACEMENT SMALL STAND ON		
6	86319650	2	SPROCKET, DRIVE, 14T		
7	86319640	1	CHAIN, ISO O8B, 12.7MM PITCH		
8	86319620	1	FRAME, LOWER DRIVE		
9	86316890	1	WHEEL, PU 200MM X 50MM		
10	86279630	3	WASHER, .344IDX1.130ODX.09T PLT		
11	86358800	5	WASHER, M6 CONICAL		
12	86010670	4	WASHER, 5/16 X 3/4 SS		
13	86008610	4	FLANGE, BEARING PRESSED STEEL		
14	86272550	3	PIN, CLEVIS, 5/16 X 1.00 PLTD		
15	86276070	4	SCR, 5/16-18 X 3/4 CARRIAGE SS		
16	86358820	3	SCREW, M6-1.0 X 16 HCS 10.9Z		
17	86136640	3	SCR, M8 X 20 HHMS		
18	86358810	2	SCREW, M6 - 1.0 X 30 HCS 10.9Z		
19	86270830	4	NUT, 5/16-18 HEX NYLOCK SS		
20	86219640	1	KEY, 1/4 SQ. X 1.5		
21	86332380	3	ROLLER, 1.1 OD		
22	86001030	2	BEARING, BALL 3/4 BORE SPHERED		
23	86008660	3	COTTER 5/16" RING		
24	86333870	1	LEVER DRIVE ENGAGEMENT		DELUXE ONLY
25	86271240	1	NUT, CAP 1/4 DIA RETAINING PLT		DELUXE ONLY
26	86232780	-	CHAIN MASTER LINK 12.7MM		
27	86002830	1	CABLE TIE .375 X 24.7		
28	86264920	2	CABLE TIE, 7" UL/CSA	(11*)	
29	86362040	2	TAPE CLOSED CELL 1/8 X 3/4 X 2 1/2 PSA	(11*)	
30	86362140	3	SCREW, M6 X 12MM, HEX FLANGE, PLTD	(13*)	
31	86348490	1	NUT, WELD 5/16-18 X .38, TAB BASE, STL	(13*)	
32	86362130	1	SCREW, 5/16 X 1.50, SHCS, SS, FT	(13*)	
33	86362150	2	SCREW, M6 X 30MM, HEX FLANGE, PLTD	(13*)	

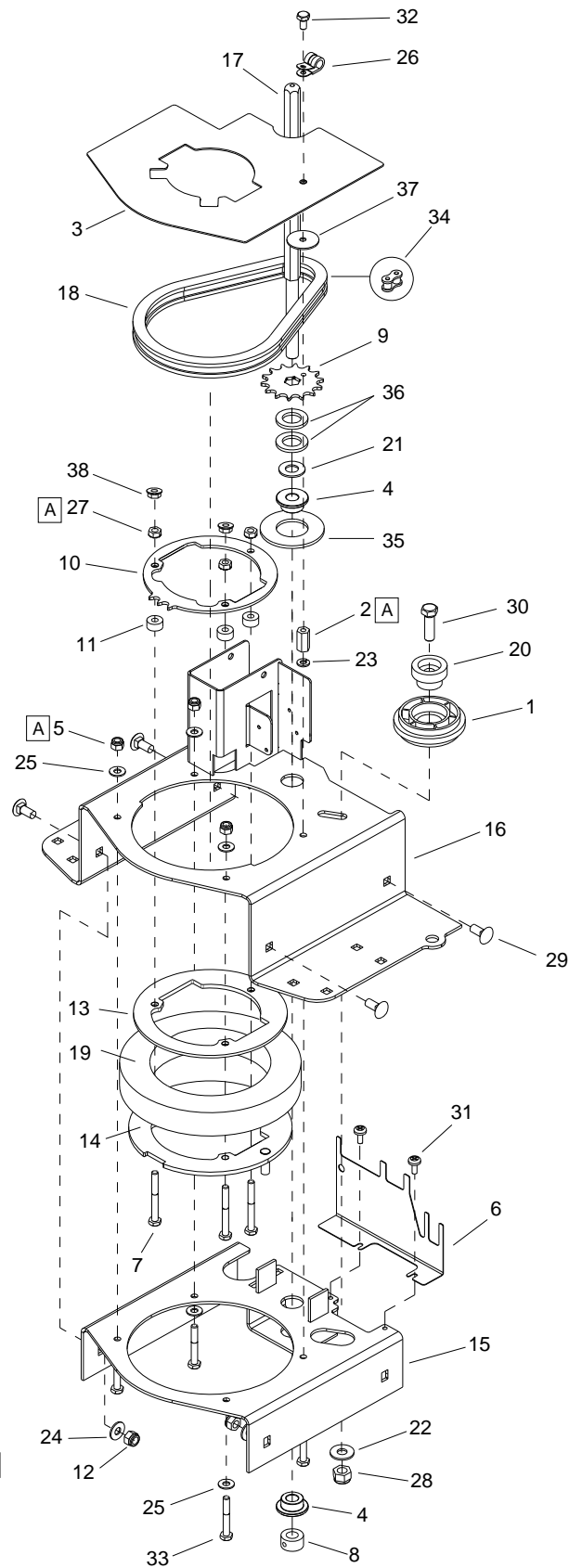

A TORQUE 78 IN/LBS

REF	PART NO.	QTY	DESCRIPTION	SERIAL NO. FROM	NOTES
1	86330720	1	CHAIN TENSIONER		
2	86329350	1	NUT, 1/4-20 X 7/8 HEX COUPLING SS		
3	86329340	1	PLATE, CHAIN GUARD		
4	86328050	2	WASHER, SHOULDER.48ID X 1.25OD		
5	86005810	3	NUT, 1/4-20 HEX NYLOCK SS		
6	86327110	1	BRACKET, CONNECTORS		
7	86273100	3	SCR, 1/4-20X2-1/4 HXHD CAP		
8	86322060	1	COLLAR, 12MM ID		
9	86322050	1	SPROCKET, STEERING, 14T		
10	86322040	1	PLATE, CHAIN RING		
11	86322030	3	SPACER		
12	86270830	7	NUT, 5/16-18 HEX NYLOCK SS		
13	86319740	1	PLATE, UPPER CLAMP		
14	86319680	1	PLATE, LOWER CLAMP		
15	86319610	1	BRACKET, BEARING CLAMP		
16	86319600	1	BRACKET, DRIVE MOUNT		
17	86319590	1	SHAFT, STEERING SPROCKET		
18	86319560	1	CHAIN, ISO O8B, 12.7MM PITCH		
19	86014440	1	BEARING, DRIVE		
20	86224270	1	SLEEVE, CHAIN TENSIONER		
21	86259430	1	WASHER, 12.5 ID X 26 OD X 2T FLAT		
22	86279510	1	WASHER, 3/8 X 1 FLAT NP		
23	86010780	1	WASHER, 1/4 SPLIT		
24	86010670	4	WASHER, 5/16 X 3/4 SS		
25	86010630	7	WASHER, 1/4 X 5/8 FLAT SS		
26	86363870	1	CLAMP, 5/8" OD CUSHIONED		
27	86005710	3	NUT, 1/4-20 HEX W/STAR		
28	86271930	1	NUT, 3/8-16 HEX NYLOCK SS		
29	86276070	4	SCR, 5/16-18 X 3/4 CARRIAGE SS		
30	86275190	1	SCR, 3/8-16 X 1.25 HHCS SS		
31	86006800	2	SCR, 10-32 X 1/2 PHTR PLT		
32	86274760	1	SCR, 1/4-20 X 1/2 HHCS		
33	86274150	4	SCR, 1/4-20 X 1.75 HHCS		
34	86232780	-	CHAIN MASTERLINK 12.7MM		
35	86368600	1	WASHER, 2.50ODx1.25IDx.125THK, DELRIN		
36	86279420	2	WASHER .75IDx1.25ODx.125THK NY		
37	86278940	1	WASHER 1/4 ID X 1-1/4 OD PLT	(11*)	
38	86271370	2	NUT, 1/4-20 SERFLG STL ZNPLT		

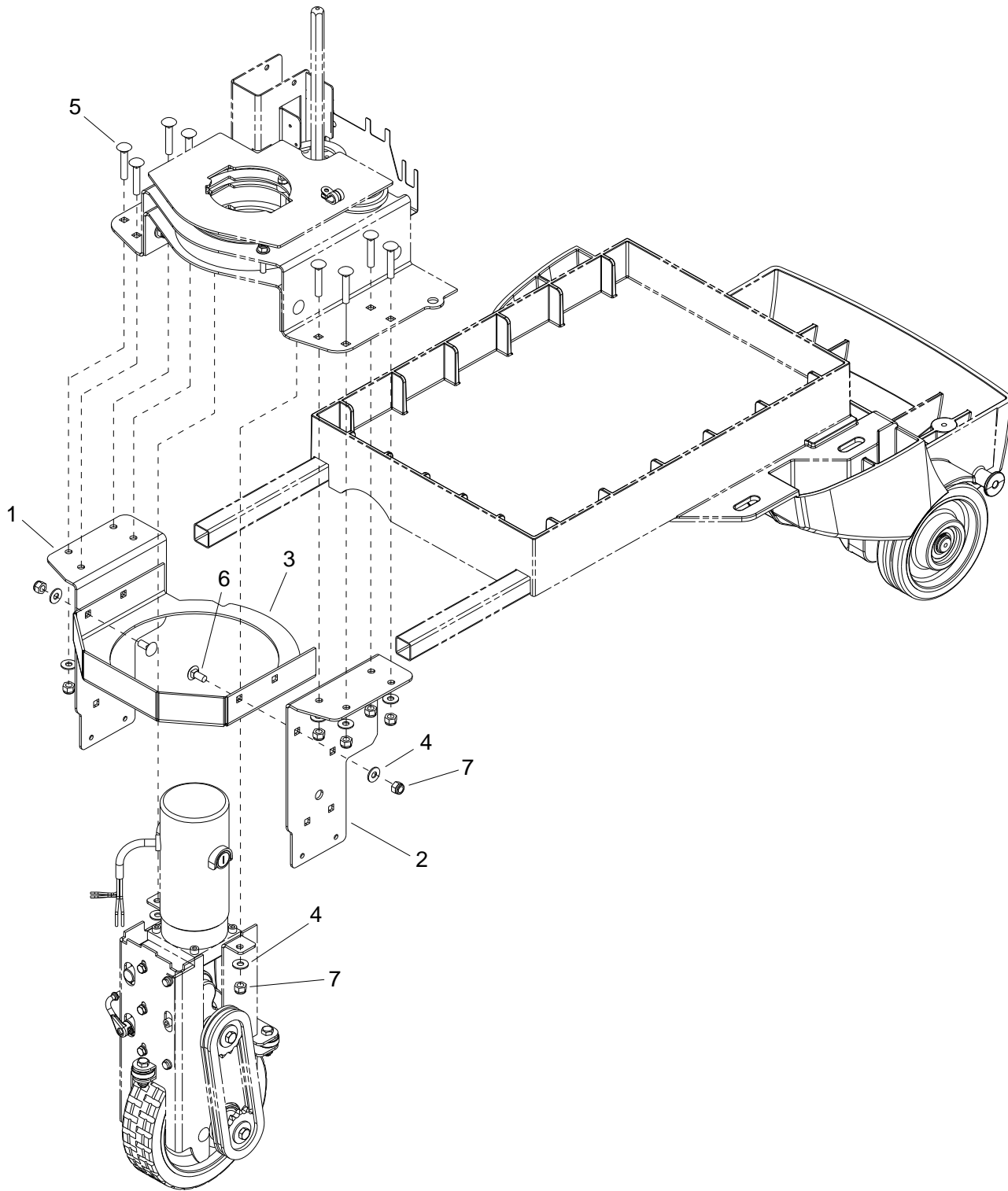

REF	PART NO.	QTY	DESCRIPTION	SERIAL NO. FROM	NOTES
1	86344620	1	BRACKET, LINKAGE MOUNT		
2	86319730	1	BRACKET, LINKAGE MOUNT, LEFT		
3	86331630	1	BRACKET, ROLLER GUIDE		
4	86010670	12	WASHER, 5/16 X 3/4 SS		
5	86276690	8	SCR, 5/16-18 X 1.75 CARR SS		
6	86276070	2	SCR, 5/16-18 X 3/4 CARRIAGE SS		
7	86270830	12	NUT, 5/16-18 HEX NYLOCK SS		

Frame & Rear Wheels

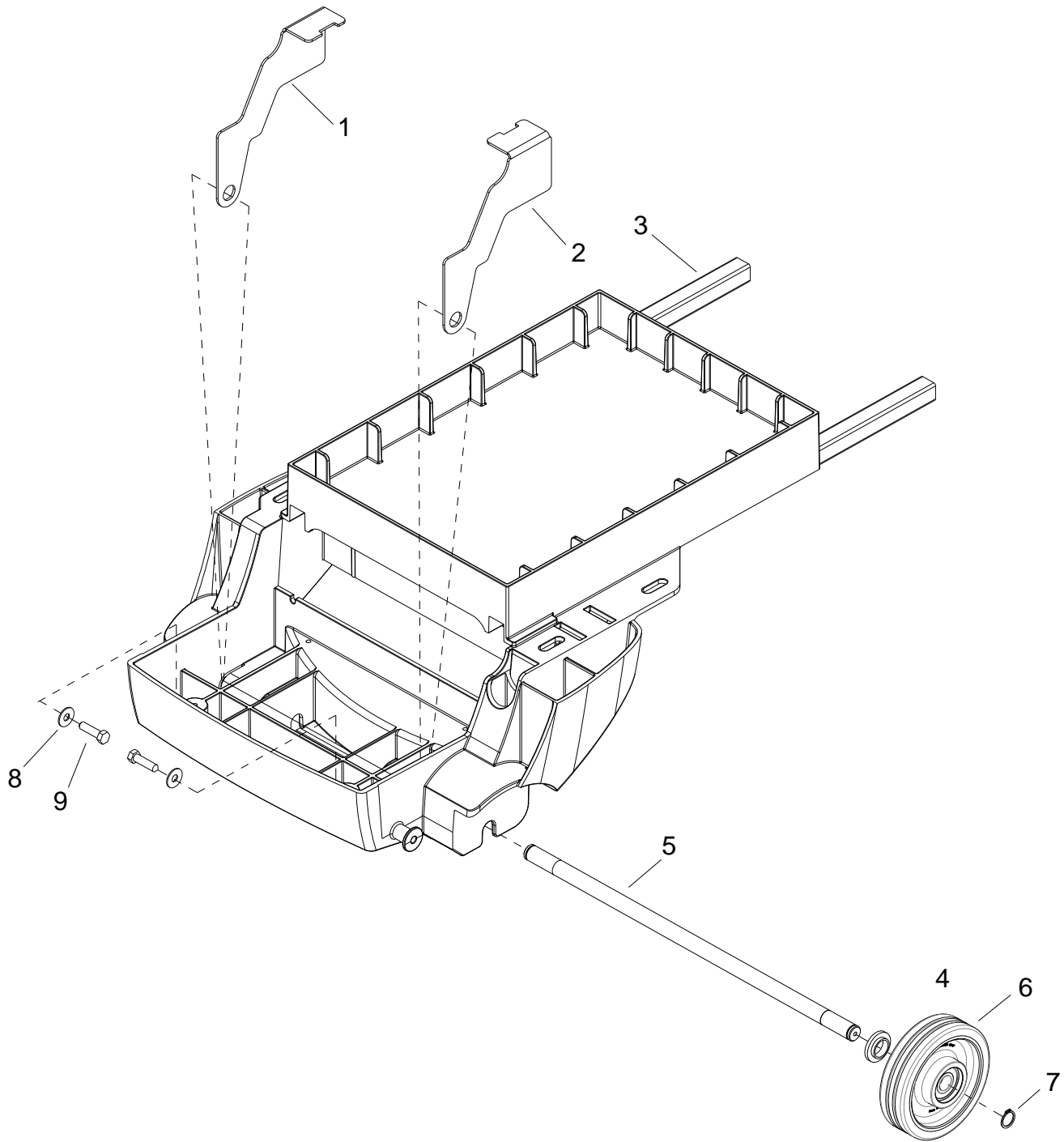

REF	PART NO.	QTY	DESCRIPTION	SERIALNO. FROM	NOTES
1	86326260	1	BRACKET, FRAME LEFT		
2	86326250	1	BRACKET, FRAME RIGHT		
3	86340610	1	ASM FRAME, CS20		INCLUDES ITEM 8 & 9
4	86326220	2	SPACER, FLG .887ID X 1.055D X .345LG		
5	86318030	1	AXLE, 20MM X 562 MM		
6	86369160	2	WHEEL, 6.00 X 1.58, GRY W/BEARINGS	(15*)	
7	86223470	2	RING, 20MM EXTERNAL SNAP		
8	86279510	2	WASHER 3/8 FLAT		
9	86340950	2	SCR, 3/8 X 1.5, LAG, PLTD		

* SEE SERIAL NUMBER PAGE

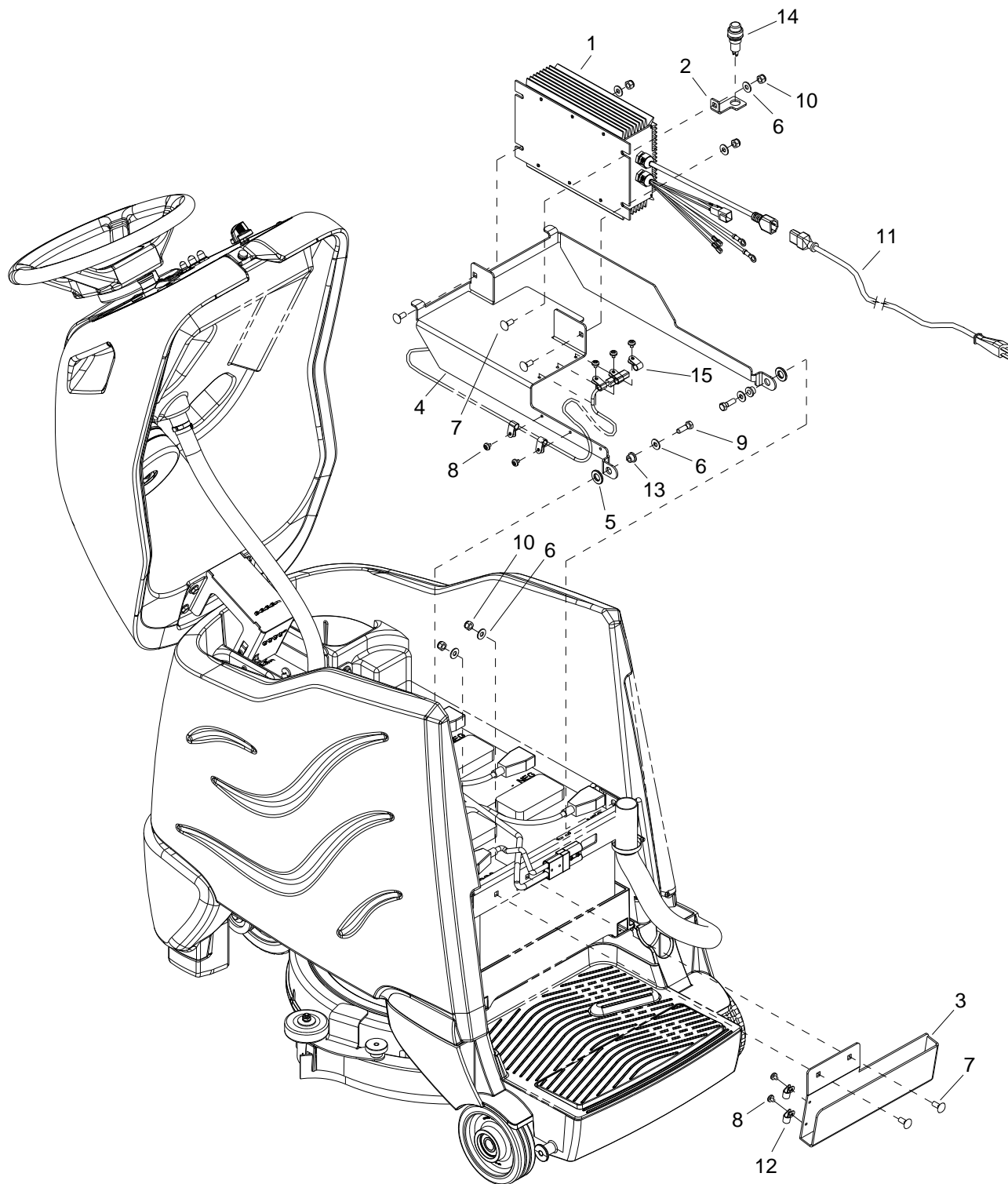

REF	PART NO.	QTY	DESCRIPTION	SERIAL NO. FROM	NOTES
1	86370690	1	KIT, CHARGER		▲
2	86332690	1	BRKT, CHARGER METER		
3	86332370	1	BRACKET, CORD WRAP		
4	86327690	1	BRACKET, CHARGER		
5	86259400	2	WASHER, THRUST .51 ID X 1 ODBRO		
6	86010670	7	WASHER, 5/16 X 3/4 SS		
7	86276070	5	SCR, 5/16-18 X 3/4 CARRIAGE SS		
8	86359740	7	SCR, 10-32 X 5/16 HWHTR		
9	86006750	2	SCR, 5/16-18 X 1.00 HHCS GR5		
10	86270830	5	NUT, 5/16-18 HEX NYLOCK SS		
11	86234390	1	CORD ASM, 16/3 SJTWX2M IEC		
12	86198450	2	CLAMP, 5/16 DIA NYLON		
13	86228990	2	BEARING FLG .314IDX.5002OD		
14	86333070	1	METER, SPE BATTERY CHARGE		
15	86198470	5	CLAMP, 9/16 DIA NYLON		

▲ FOR REPLACEMENT, ORDER KIT # 86375240, KIT, DELTA Q CONVERSION

On Board Battery Charger-Deluxe & Cylindrical

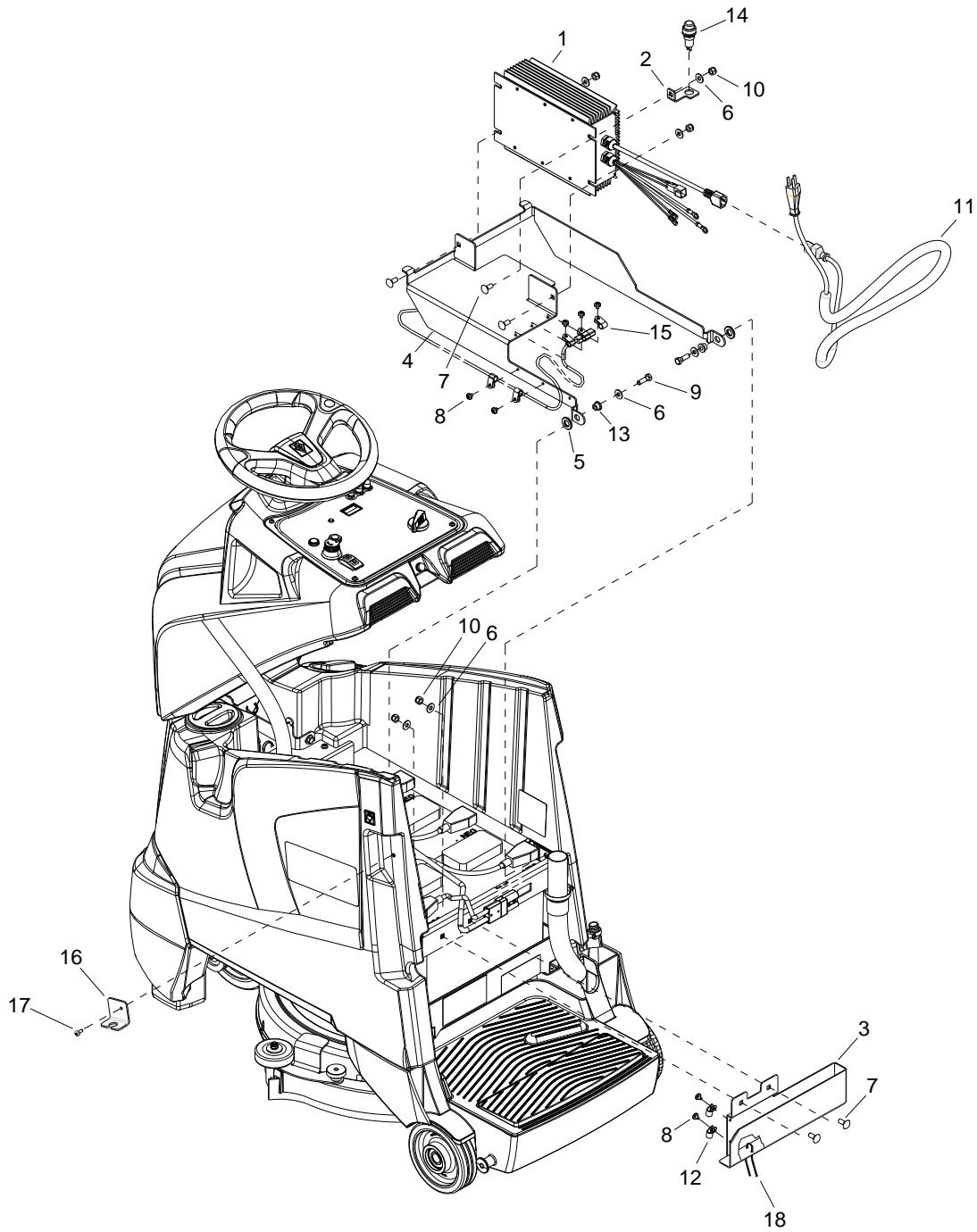

On Board Battery Charger-Deluxe & Cylindrical

REF	PART NO.	QTY	DESCRIPTION	SERIAL NO. FROM	NOTES
1	86370690	1	KIT, CHARGER		▲
2	86332690	1	BRKT, CHARGER METER		
3	86348390	1	BRACKET, CORD STORAGE DELUXE		
4	86327690	1	BRACKET, CHARGER		
5	86259400	2	WASHER, THRUST .51 ID X 1 ODBRO		
6	86010670	7	WASHER, 5/16 X 3/4 SS		
7	86276070	5	SCR, 5/16-18 X 3/4 CARRIAGE SS		
8	86359740	7	SCR, 10-32 X 5/16 HWHTR		
9	86006750	2	SCR, 5/16-18 X 1.00 HHCS GR5		
10	86270830	5	NUT, 5/16-18 HEX NYLOCK SS		
11	86345510	1	CORD, ONBOARD CHARGER, 16/3C SJTO		
12	86198450	2	CLAMP, 5/16 DIA NYLON		
13	86228990	2	BEARING FLG .314IDX.5002OD		
14	86333070	1	METER, SPE BATTERY CHARGE		
15	86198470	5	CLAMP, 9/16 DIA NYLON		
16	86333940	-	BRACKET, CHARGER CORD		
17	86006590	1	SCREW 10-32 X 1/2 PPHMS SS NP		
18	86264940	1	CABLE TIE, 11.38" UL/CSA		

▲ FOR REPLACEMENT, ORDER KIT # 86375590, KIT, DELTA Q CONVERSION DLX

Pedal Platform

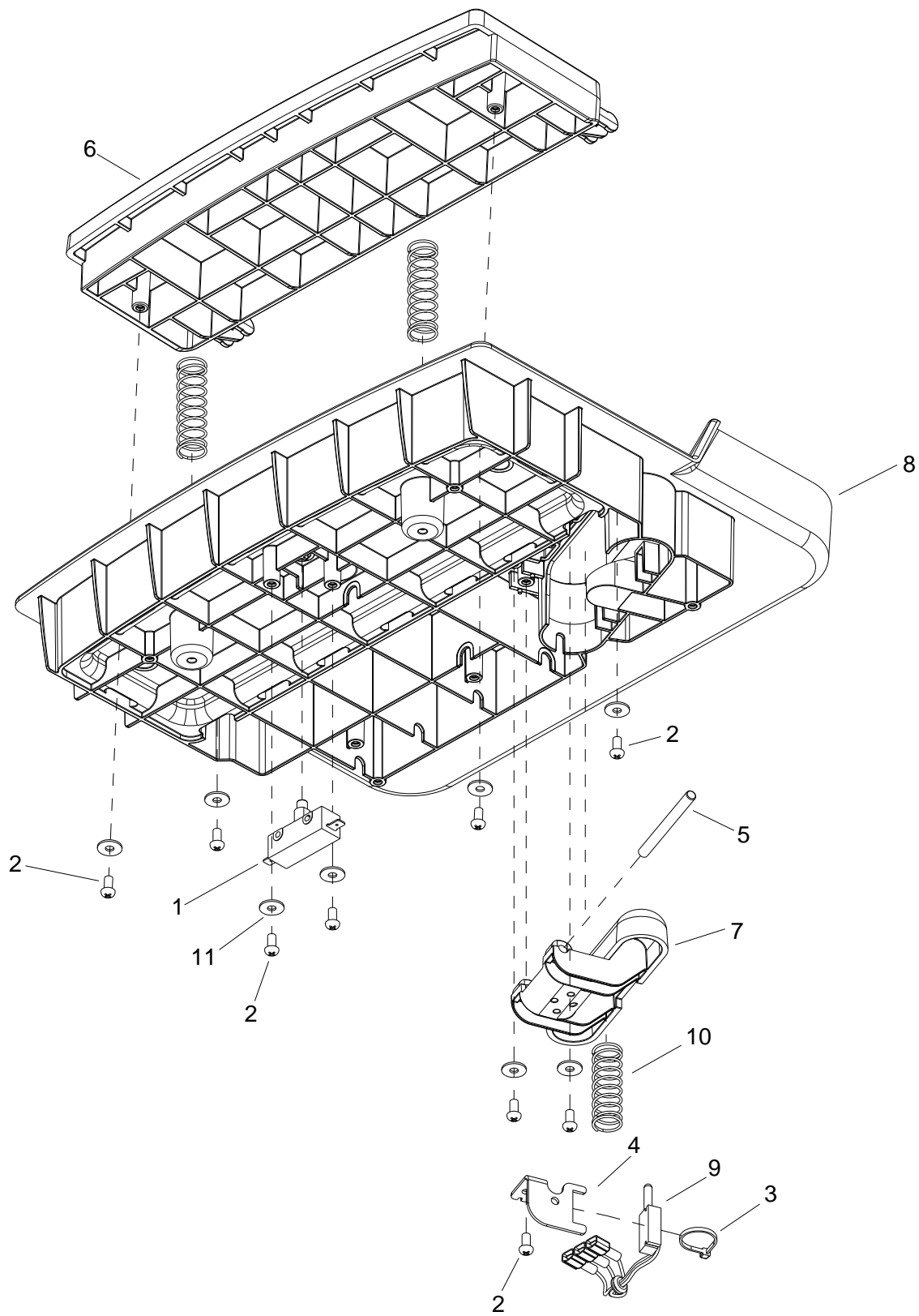

REF	PART NO.	QTY	DESCRIPTION	SERIAL NO. FROM	NOTES
1	86007110	1	SWITCH, 25A SPST 125-250V SNAP		
2	86172980	9	SCR, KA50X10, PT OHS, WN1412, PLTD		
3	86264930	1	CABLE TIE, 3.5" UL/CS		
4	86326150	1	BRKT, LINEAR POT		
5	86326140	1	PIN, DOWEL .25 X 2.75, STEEL		
6	86318010	1	PEDAL, HEEL		
7	86318000	1	PEDAL, ACCELERATOR		
8	86317990	1	PLATFORM, OPERATOR		
9	86311560	1	POTENTIOMETER ASM, LINEAR		
10	86254970	3	SPRING, COMP 18MM OD X 83 X 2		
11	86173330	8	WASHER, M5, FLAT, ISO7093, SS		

Pedal Platform Mounting

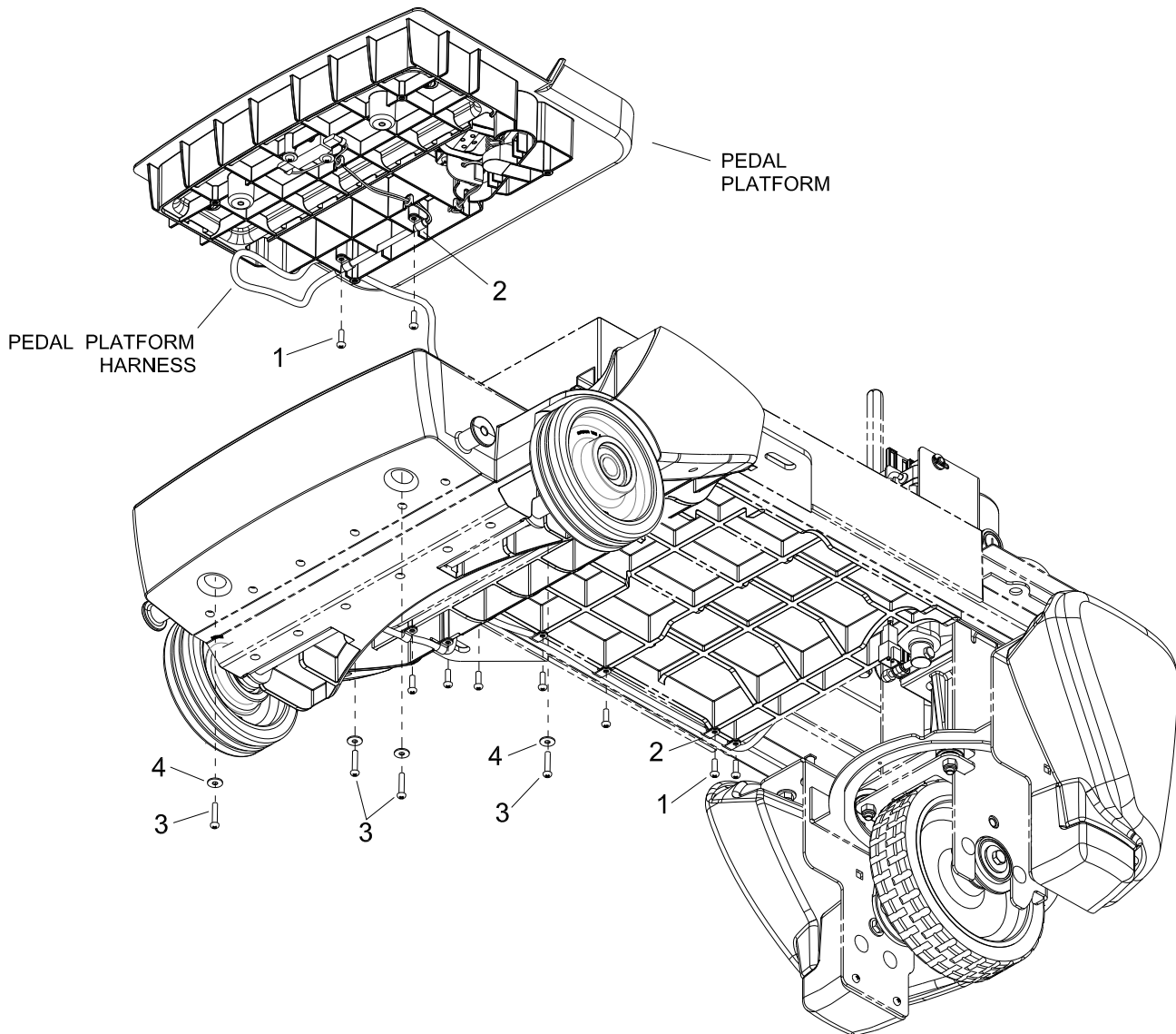

REF	PART NO.	QTY	DESCRIPTION	SERIAL NO. FROM	NOTES
1	86327510	9	SCR, KA50 X 16, WN1412 A2 SS		
2	86198440	9	CLAMP, 1/4 PLASTIC CABLE		
3	86327910	4	SCR, KA50X25, PT OHS, WN1412, PLTD		
4	86173330	4	WASHER, M5, FLAT, ISO7093, SS		

Recovery Tank

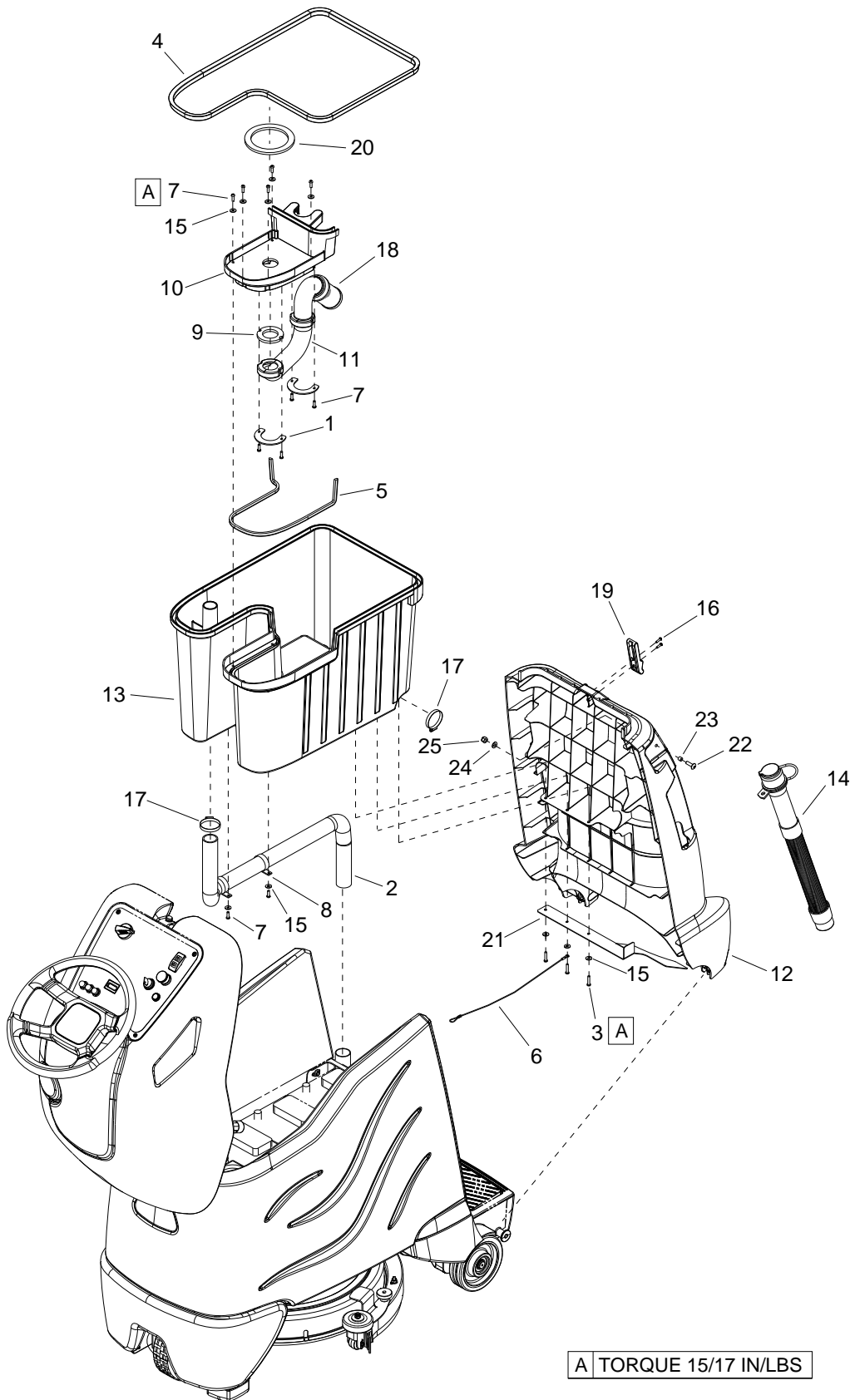

REF	PART NO.	QTY	DESCRIPTION	SERIAL NO. FROM	NOTES
1	86329510	2	PLATE, INTAKE RETAINER		
2	86328020	1	HOSE ASM, 1.25 ID X 14.0, 4:1		
3	86327910	3	SCR, KA50X25, PT OHS, WN1412, PLTD		
4	86327850	1	GASKET, REC TANK 68"		
5	86327840	1	GASKET, VAC MOUNT 27"		
6	86327590	1	LANYARD, 15.0 W/LOOP & EYE		
7	86327510	11	SCR, KA50X16, PT OHS, WN1412, A2 SS		
8	86326270	2	CLAMP, 1.5 DIA		
9	86326200	1	GASKET, VACUUM INTAKE		
10	86318220	1	FRAME, VACUUM MOTOR		
11	86318210	1	INTAKE, VACUUM		
12	86344710	1	PANEL, BACK		
13	86317920	1	TANK, RECOVERY		
14	86302360	1	DRAIN HOSE, CMPS		
15	86173330	10	WASHER, M5, FLAT, ISO7093, SS		
16	86173140	2	SCR,KA40X16,PT OVAL,WN1412,PL		
17	86002400	2	CLAMP, 2.00 WORM GEAR X .312		
18	86356060	1	FLOAT ASM, DUAL BALL SCREEN	*(11)	
19	86161800	1	LATCH, CONCEALED KEEPER		
20	86312920	1	GASKET, VAC MOTOR		
21	86335700	1	BRACKET, DRAIN HOSE	*(3)	
22	86007070	1	SCREW 5/16-18 X 1.00 PTHMS SS	*(6)	
23	86007650	1	SPACER, .438D X .317ID X .25L	*(6)	
24	86010670	1	WASHER 5/16 FLAT SS	*(6)	
25	86270830	1	NUT 5/16-18 HEX NYLOCK SS	*(6)	

* SEE SERIAL NUMBER PAGE.

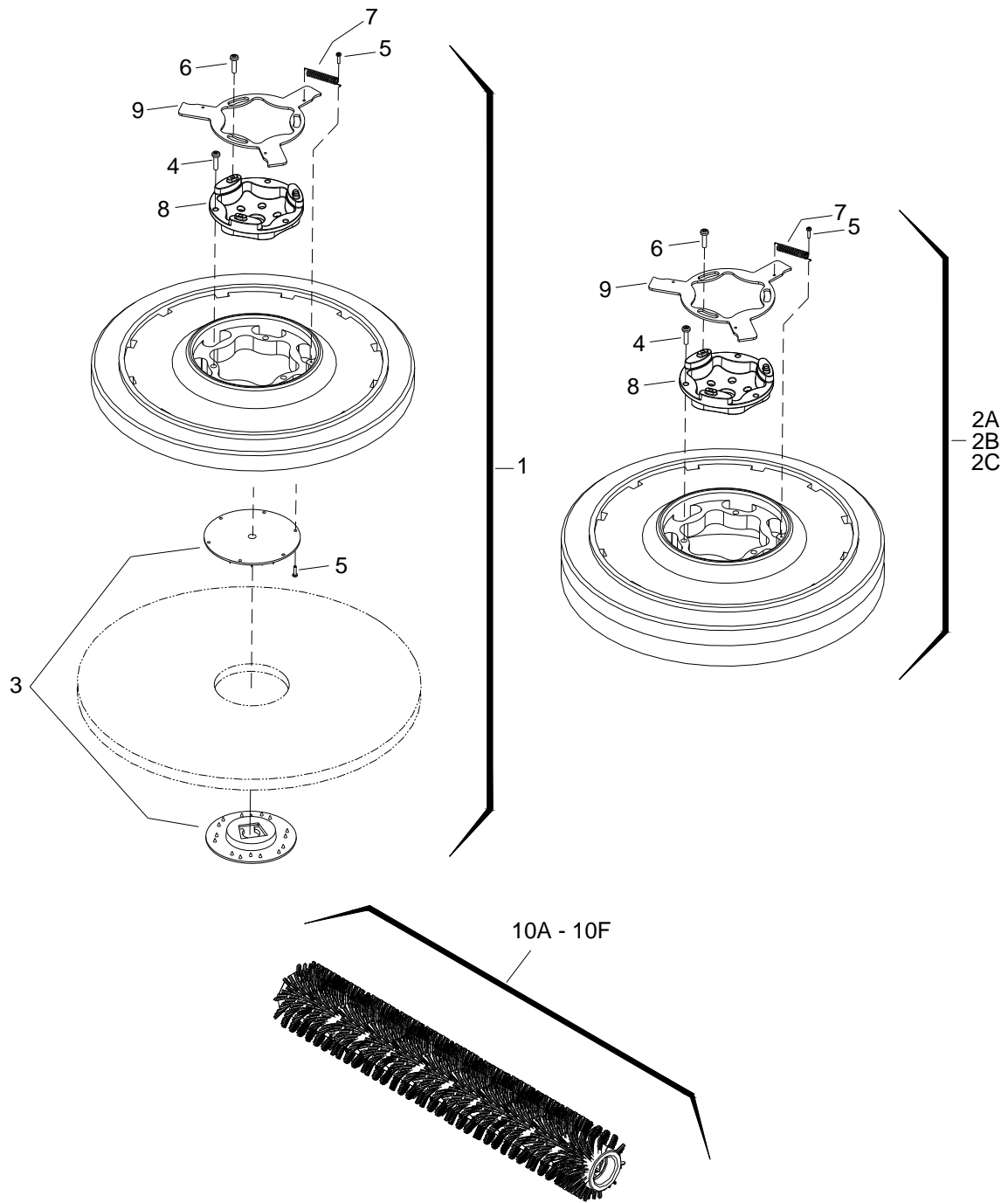

REF	PART NO.	QTY	DESCRIPTION	SERIAL NO. FROM	NOTES:
1	86000410	1	PAD DRIVER, 20" SD		
2A	86000420	1	BRUSH, 20" POLYPROPYLENE SD		
2B	86000430	1	BRUSH, 20" NYLON SD		
2C	86283870	1	BRUSH, 20" NYLON POLISH SD		
3	86005070	1	LOCK, PAD CENTER SNAP, TWO STEP		
4	86276590	3	SCR, #12 X 1 PPHSMS SS		
5	86276580	1	SCR, 8-32 X 3/4 PTHMS		
6	86276600	3	SCR, #10 X 3/4 PTHSMS SS		
7	86007910	1	SPRING, EXT .31 D X 2.0 L X .03 W SS		
8	86007280	1	SOCKET, DRIVE BRUSH		
9	86005940	1	PLATE, BRUSH RELEASE		
10A	47623930	2	ROLLER BRUSH COMPLETE RED		
10B	47624090	2	ROLLER BRUSH COMPLETE WHITE		
10C	47624100	2	ROLLER BRUSH COMPLETE ORANGE		
10D	47624110	2	ROLLER BRUSH COMPLETE GREEN		
10E	47624120	2	ROLLER BRUSH COMPLETE BLACK		
10F	41140100	2	MICROFIBRE ROLL COMPLETE BR 55/40		
	47624150	2	ROLL PAD BR55		

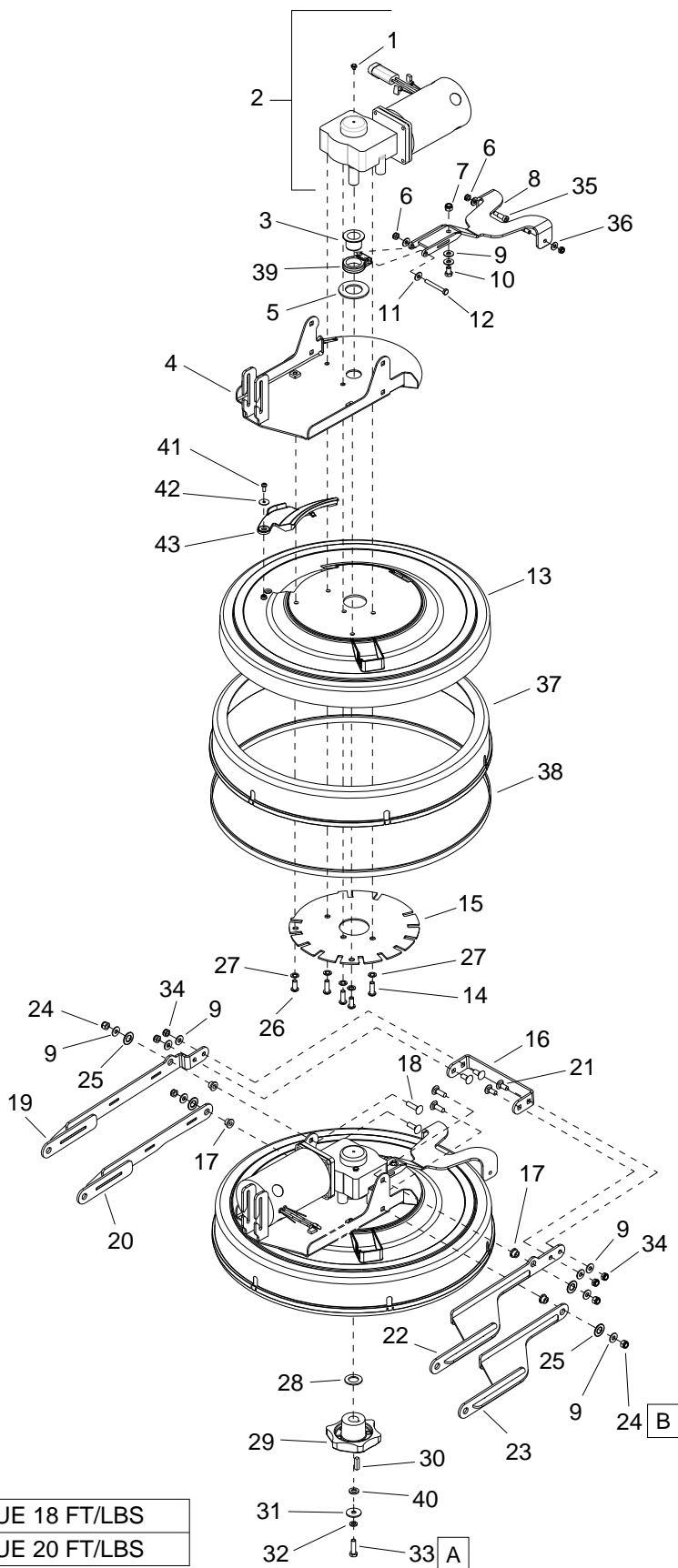

REF	PART NO.	QTY	DESCRIPTION	SERIAL NO. FROM	NOTES
1	86331340	1	BREATHER VENT, 10-32 THREAD		
2	86331970	1	MOTOR, 36VDC 180RPM RT-ANG		INCLUDES 86331340
-	86331980	-	BRUSH SET, 8.633-197.0 SCRUB MTR		
3	86325200	1	BUSHNG, 30MM, BRNZ		
4	86326430	1	SUPPORT ASSY, MOTOR, BRUSH DECK		
5	86326560	1	WASHER, NYLON, 2.28ODX1.28IDX.12 THK		
6	86271870	3	NUT, 1/4-20 HEX NYLCK THIN SS		
7	86222300	1	NUT, 5/16-18 JAM SS C		
8	86320370	1	LINKAGE ARM ASSY, PIVOT SQUG		
9	86010670	10	WASHER 5/16 FLAT SS		
10	86328620	1	SCR, 5/16-18 X 1/2 LG, HHCS, BLK NYLON		
11	86279070	2	WASHER, M6 FLAT		
12	86273850	1	SCR, 1/4-20 X 2 HHCS SS		
13	86319800	1	SHROUD, 20" SCRUB DECK		
14	86329560	3	SCR, M8X1.25X25MM LG, BSHCS, SS		
15	86326550	1	SUPPORT PLATE, SHROUD		
16	86326540	1	BRIDGE BRKT, DECK LIFT		
17	86228990	4	BEARING, FLNGD, .314ID X .502OD		
18	86277130	4	SCREW 5/16-18X1.00 CARRIAGE SS		
19	86326600	1	BRKT, DECK LIFT, UPPER RIGHT		
20	86326610	1	BRKT, DECK LIFT, LOWER RIGHT		
21	86276070	4	SCR, 5/16-18 X 3/4 CARRIAGE SS		
22	86326580	1	BRKT, DECK LIFT, UPPER LEFT		
23	86326590	1	BRKT, DECK LIFT, LOWER LEFT		
24	86270830	4	NUT 5/16-18 HEX NYLOCK SS		
25	86259410	4	WASHER THRUST.51 ID X1ODX.063		
26	86290040	2	SCR, 5/16-18 X 3/4 BSHCS SS		
27	86330990	5	WASHER, 5/16 INT STAR, SS		
28	86337200	1	WASHER, 19MM X 34MM X 3MM FLAT SS	*(1)	
29	86003420	1	DRIVER, BRUSH SD		
30	86004810	1	KEY, 1/4 SQ X 1.00		
31	86279630	1	WASHER, .344IDX1.13ODX.09T PLT		
32	86279130	1	WASHER 5/16 SPLIT LOCK PLTD		
33	86330970	1	SCR, M8X1.25X25MM LG, HHCS, SS		
34	86271840	4	NUT 5/16-18 HEX NYLOCK THIN SS		
35	86327700	2	SHOULDER BOLT, 5/16 X 5/8 LG SS		
36	86010630	2	WASHER 1/4 ID X 5/8 OD SS		
37	86320430	1	20" BRUSH SKIRT		
38	86328220	1	FLEXIBLE STRIP BRUSH, 20" SKIRT		
39	86319820	1	PIVOT, SQUEEGEE LINKAGE		
40	86338440	1	SPACER, .41 ID X .73 OD X .105T	*(1)	
41	86006870	1	SCREW #10B X 1/2 PHMS BLK		
42	86335450	1	WASHER, #10 X .75 ODX.040. NYL, BLK		
43	86324480	1	ACCESS COVER, BRUSH RELEASE		

* SEE SERIAL NUMBER PAGE

** CALL MANUFACTURER FOR SERIAL NUMBER

Scrub Brush Deck Mounting-Disk

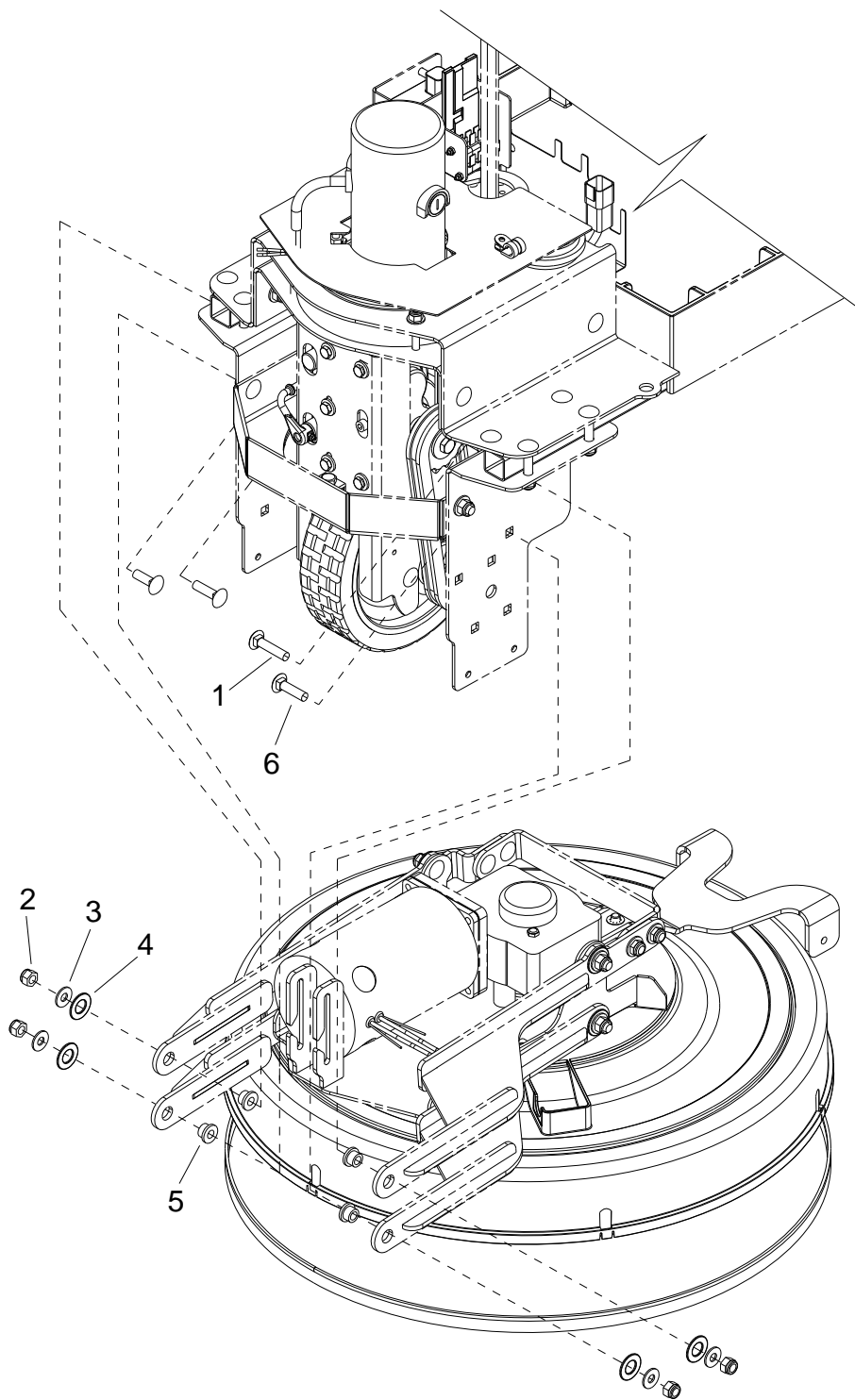

REF	PART NO.	QTY	DESCRIPTION	SERIAL NO. FROM	NOTES
1	86277030	4	SCR, 5/16-18X1.25 CARRIAGE S		
2	86270830	4	NUT 5/16-18 HEX NYLOCK SS		
3	86010670	4	WASHER 5/16 FLAT SS		
4	86259410	4	WASHER THRUST.51 ID X1ODX.063		
5	86228990	4	BEARING,FLNGD, .314ID X.502OD		
6	86277130	2	SCR, 5/16-18 X 1.00 CARRIAGE SS		

Scrub Deck Drive Assembly-Cylindrical

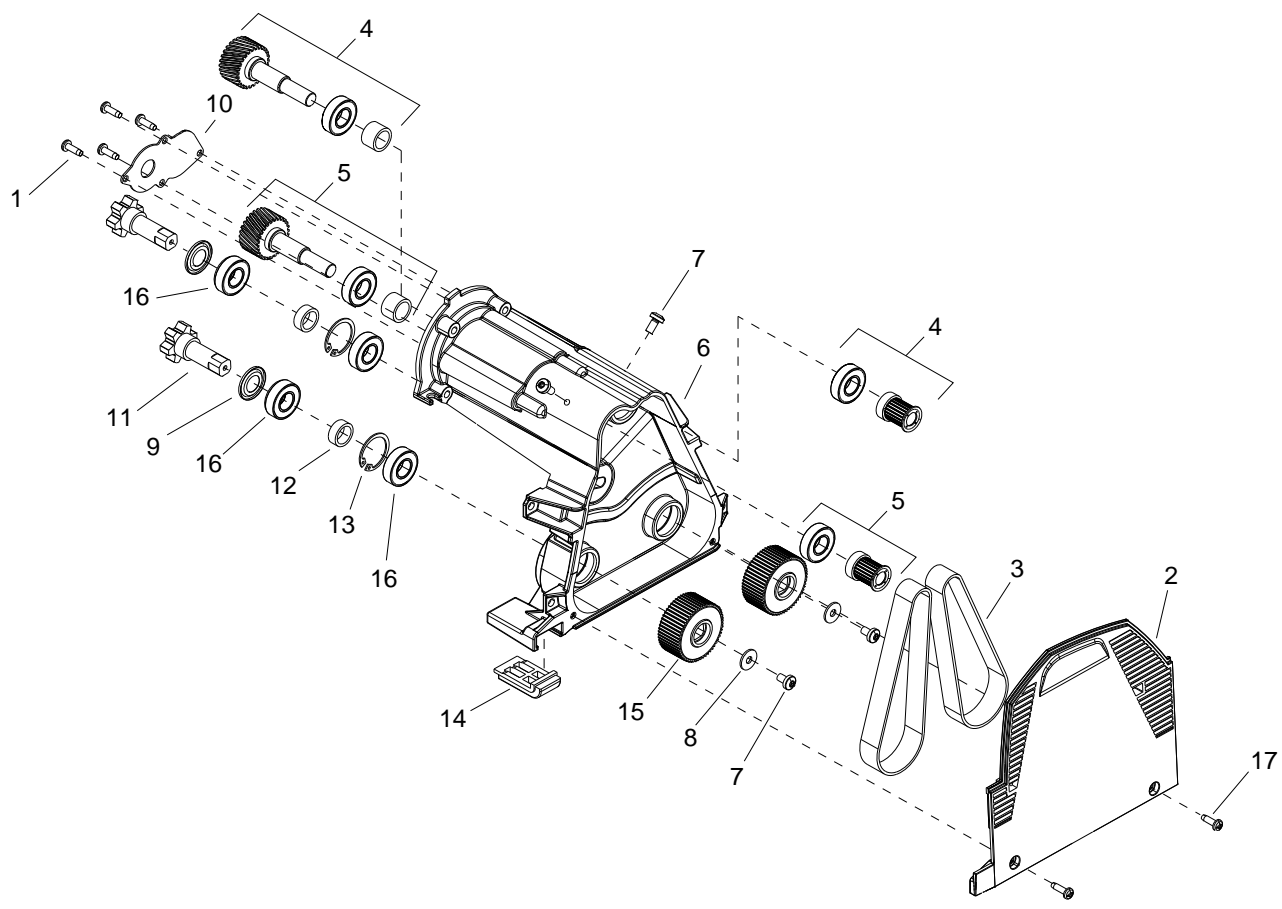

REF	PART NO.	QTY	DESCRIPTION	SERIAL NO. FROM	NOTES
1	73031040	4	SCREW 5X16 -A2-70 (IN6RD)		
2	50353850	1	COVER GEAR		
3	40350050	2	TOOTHED BELT REPLACEMENT		*
4	40353810	1	SHAFT GEAR RIGHT		*
5	40353800	1	SHAFT GEAR LEFT		*
6	50353840	1	CARRIER MOTOR WORKED R		
7	73060890	3	SCREW M6X12 -8.8-R2R (IN6RD)		
8	73122760	2	WASHER 6 -200HV-A2E ISO7093-1		
9	63634690	2	JOINT RING STAINLESS STEEL NILOS 6002		
10	50356840	1	COVERING CAP GEAR		*
11	51011040	2	DRIVESHAFT		
12	51106860	2	SPACER SLEEVE		
13	73432310	2	LOCKING RING 32X1,2 -ST-PH DIN 472		
14	50560100	1	ROCKER BR-VS		
15	56255070	2	BELT PULLEY 56Z		
16	74011150	4	BALL BEARING 6002-2RS -WAE LZLAGST DIN 6		
17	73030390	2	SCREW M5x16 -St-A2R (In6Rd)		

* IF 50356840 IS METAL, ORDER 40350050, 40353810, 40353800, AND 50356840.

Scrub Deck-Cylindrical

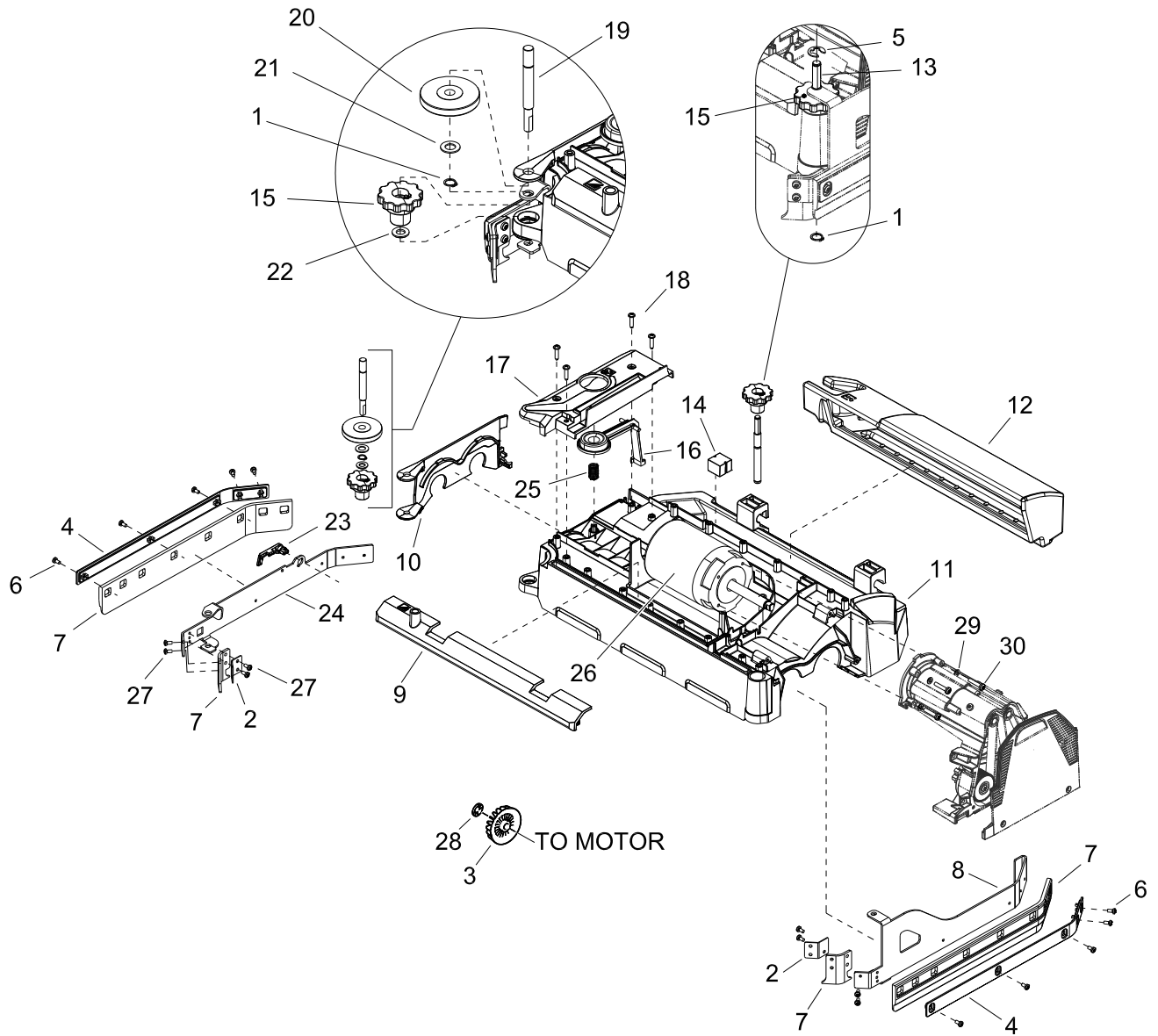

REF	PART NO.	QTY	DESCRIPTION	SERIAL NO. FROM	NOTES
1	73430030	2	LOCKING RING 12X1-RF-ST DIN 471		
2	50353570	2	SIDE PLATE RUBBER LIP		
3	66130250	1	BLOWER WHEEL		
4	50354270	2	SCREEN SUCTION LIPS		
5	73430470	1	LOCK WASHER 10-FST-A2E DIN 6799		
6	73061810	10	SCREW M 5X 12-A2-70 (IN6RD)		
7	40354040	2	SET SIDE STRIP		
8	50354310	1	BRACKET SCRAPER LIP LEFT		
9	50355580	1	STRIP WATER DISTRIBUTOR		
10	50353930	1	BRUSHES RETAINER		
11	50353890	1	HOUSING BOTTOM PART R 55		
12	50353990	1	SWEEP TANK R 55		
13	51163390	1	THREADED BOLT		
14	50354260	1	PLUG HEAD R		
15	50336660	2	ADJUSTMENT WHEEL		
16	50354580	1	BRUSHES LOCKING PART		
17	50354050	1	HOUSING TOP PART LOCKING PART		
18	73031130	8	SCREW 6X25 -10.9-A2R (IN6RD)		
19	50354320	1	BOLT DEFLECTOR ROLL RIGHT KILLER		
20	50354380	1	DEFLECTOR ROLL		
21	51156810	1	WASHER		
22	73120660	1	WASHER 10 -A2 ISO 7090		
23	50354290	1	LOCKING BAR SIDE PLATE		
24	50354300	1	BRACKET SCRAPER LIP RIGHT		
25	63304500	1	PRESSURE SPRING		
26	40353780	1	MOTOR WITH PLUG		
27	73061800	8	SCREW M5x10-A2-70 (In6Rd)		
28	63431490	1	QUICK-FASTENER		
29	73120260	4	WASHER 6 -A2 ISO 7090		
30	73061960	4	SCREW M 6x30-A2-70 (IN6RD)		

Scrub Deck Linkage-Cylindrical

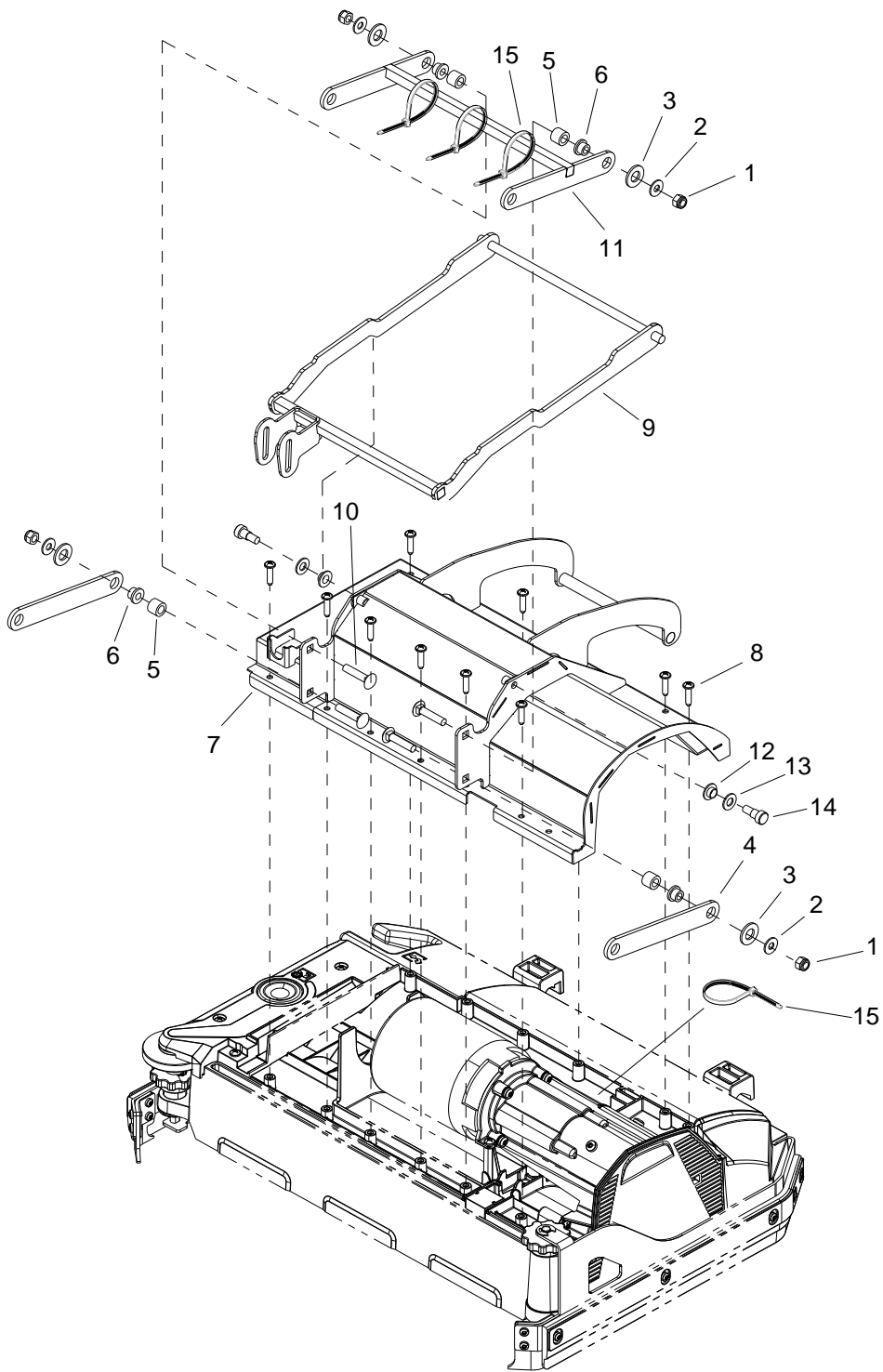

REF	PART NO.	QTY	DESCRIPTION	SERIAL NO. FROM	NOTES
1	86270830	4	NUT 5/16-18 HEX NYLOCK SS		
2	86010670	4	WASHER 5/16 FLAT SS		
3	86259410	4	WASHER THRUST.51 ID X1ODX.063		
4	86347930	2	BRACKET, LINKAGE, BOTTOM		
5	86348210	4	SPACER, .381D X .63OD X .50, AL		
6	86228990	4	BEARING,FLNGD,.314ID X.502OD		
7	86346430	1	COVER, CYL DECK, 22 IN		
8	73031130	13	SCREW 6X25 -10.9-A2R (IN6RD)		
9	86346320	1	FRAME, LIFT ARM		
10	86277470	4	SCR, 5/16-18 X 1.5 CARRIAGE SS		
11	86347680	1	BRACKET, LINKAGE, TOP		
12	86347910	2	FLNG BRNG, .375 X .44, NYL		
13	86010680	2	WASHER 3/8 ID X 3/4 OD NYLON		
14	86278330	2	SHOULDER BOLT, 3/8OD X 3/8L SS		
15	86264920	4	CABLE TIE, 7" UL/CSA		

Scrub Brush Deck Mounting-Cylindrical

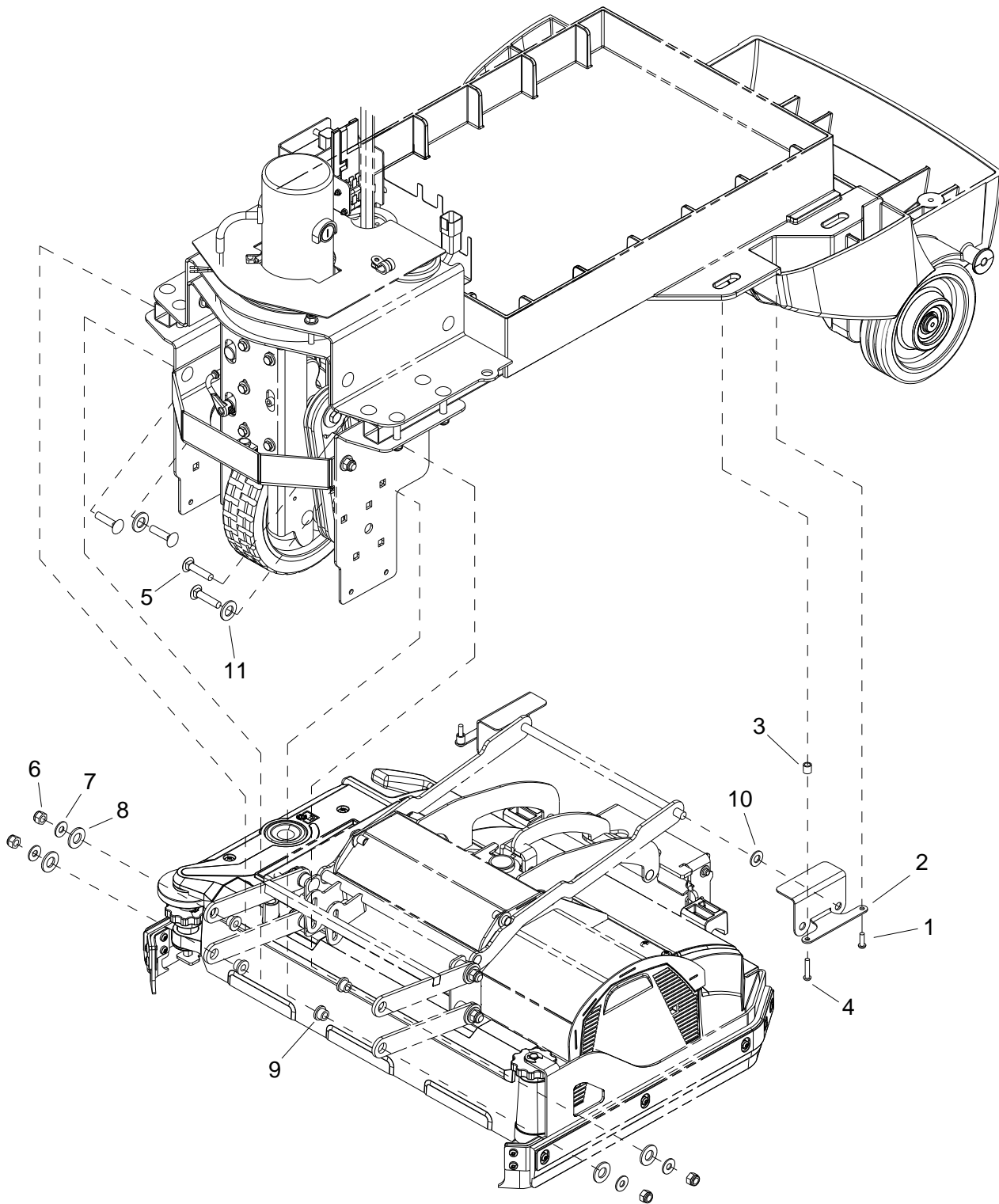

REF	PART NO.	QTY	DESCRIPTION	SERIAL NO. FROM	NOTES
1	86327510	2	SCR, KA50 X 16, WN1412 A2 SS		
2	88646520	2	BRACKET, LIFT FRAME		
3	86226760	2	SPACER, 3.8 ODX.257IDX.38L NYL		
4	86327910	2	SCR, KA50X25, PT OHS, WN1412, PLTD		
5	86277030	4	SCR, 5/16-18X1.25 CARRIAGE S		
6	86270830	4	NUT 5/16-18 HEX NYLOCK SS		
7	86010670	4	WASHER 5/16 FLAT SS		
8	86259410	4	WASHER THRUST.51 ID X1ODX.063		
9	86228990	4	BEARING,FLNGD,.314ID X.502OD		
10	86010680	2	WASHER 3/8 ID X 3/4 OD NYLON		
11	86010770	2	WASHER 7/16ID X1DX.08 FLT SS		

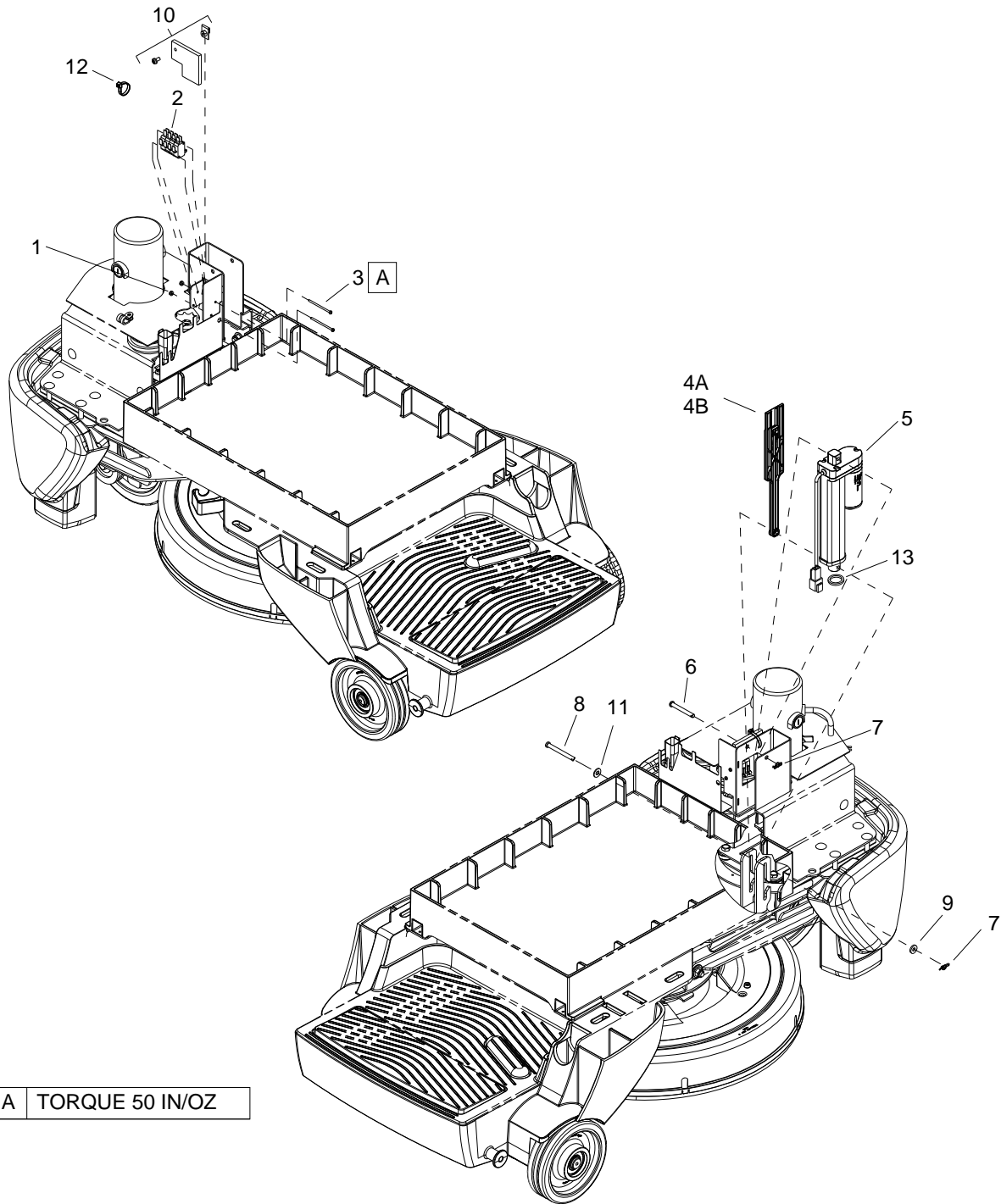

A TORQUE 50 IN/OZ

REF	PART NO.	QTY	DESCRIPTION	SERIAL NO. FROM	NOTES
1	86271660	2	NUT 4-40 HEX NYLOCK		
2	86007160	4	SWITCH 10A ROLLER MINI		
3	86327390	2	SCR, 4-40 X 2 PPHMS		
4A	86323850	1	PLATE, SWITCH ACTUATOR		DISK
4B	86346540	1	PLATE, SWITCH ACTUATOR		CYLINDRICAL
5	86320880	1	ACT, 36VDC, 3.0" STK, 8.74 LNG		
6	86328040	1	PIN, CLEVIS, 1/4 X 2.0 L		
7	86008650	2	COTTER 1/4" RING		
8	86336790	1	PIN, CLEVIS, 1/4 X 2.50. PLTD	*(2)	
9	86279610	1	WASHER, SEAL 1/4X5/8OD SS		
10	86338480	1	GUIDE PLATE ASM	*(2)	
11	86010630	1	WASHER 1/4 ID X 5/8 OD SS		
12	86264940	1	CABLE TIE, 11.38" UL/CSA	*(2)	
13	86342240	1	SPACER, .81 X 1.06 X .125	*(4)	

*SEE SERIAL NUMBER PAGE

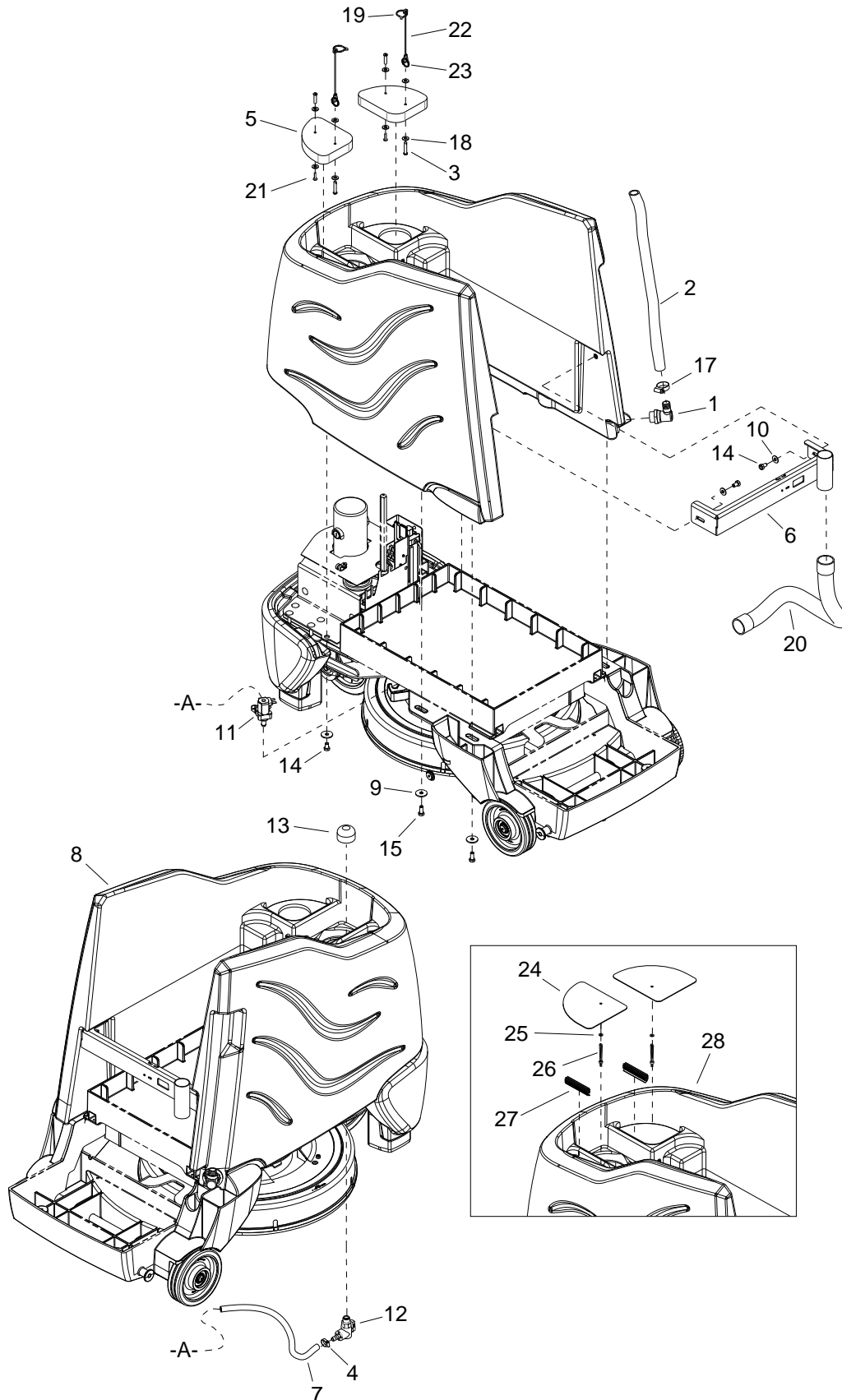

REF	PART NO.	QTY	DESCRIPTION	SERIAL NO. FROM	NOTES
1	86326310	1	FITTING, ELBOW 3/4 BSP, O-RING		
2	86326620	1	HOSE, 3/4ID X .12W X 20"LG, CLR		
3	86353910	2	PIN, CLEVIS 1/4 X 1.13 SS	*(10)	
4	86233150	1	SP CLAMP, 3/8 HOSE (D-SLOT)		
5	86353710	2	PLUG, SOLUTION FILL	*(10)	
6	86326280	1	BRACKET, TANK BRACE		
7	86321270	1	HOSE, 3/8ID WIREBOUND X 18"		
8	86355660	1	TANK, SOLUTION, CS20	*(10)	
9	86279630	5	WASHER, .344IDX1.130ODX.09T PLT		
10	86010670	2	WASHER, 5/16 X 3/4 SS		
11	86362610	1	VALVE, 36VDC SOLENOID	*(16)	
12	86346040	1	VALVE, BALL 3/8MPT X 3/8BARB, 90DEG		
13	86007970	1	STRAINER, 3/8 IN. NPT 60 MESH		
14	86275180	4	SCR, 5/16-18 X 1/2 HHCS GR5		
15	86006760	3	SCR, 5/16-18 X 3/4 HHCS GR5		
16	OPEN	-	-		
17	86233110	1	CLAMP, 1.00 WORM GEAR		
18	86010630	8	WASHER 1/4 ID X 5/8 OD SS	*(10)	
19	86264930	2	CABLE TIE, 3.5" UL/CSA	*(10)	
20	86328020	1	HOSE ASM, 1.25 ID X 14.0, 4:1		
21	86353900	2	SCR POST, 1/4 X 1 BLK PLSTC	*(10)	
22	86246090	2	LANYARD,.093X6", 1~LOOP-.26EYE	*(10)	
23	86353880	2	RING, SPLIT, ID .802" SS	*(10)	
24	86329670	2	COVER, FILL PORT		
25	86279600	2	WASHER, #6 FLAT BRASS		
26	86330960	2	LANYARD, ELASTIC, .125 X 4.0		
27	86333260	2	GASKET, 3.0", FILL PORT		
28	86317940	1	TANK, SOLUTION, CS20		

* SEE SERIAL NUMBER PAGE

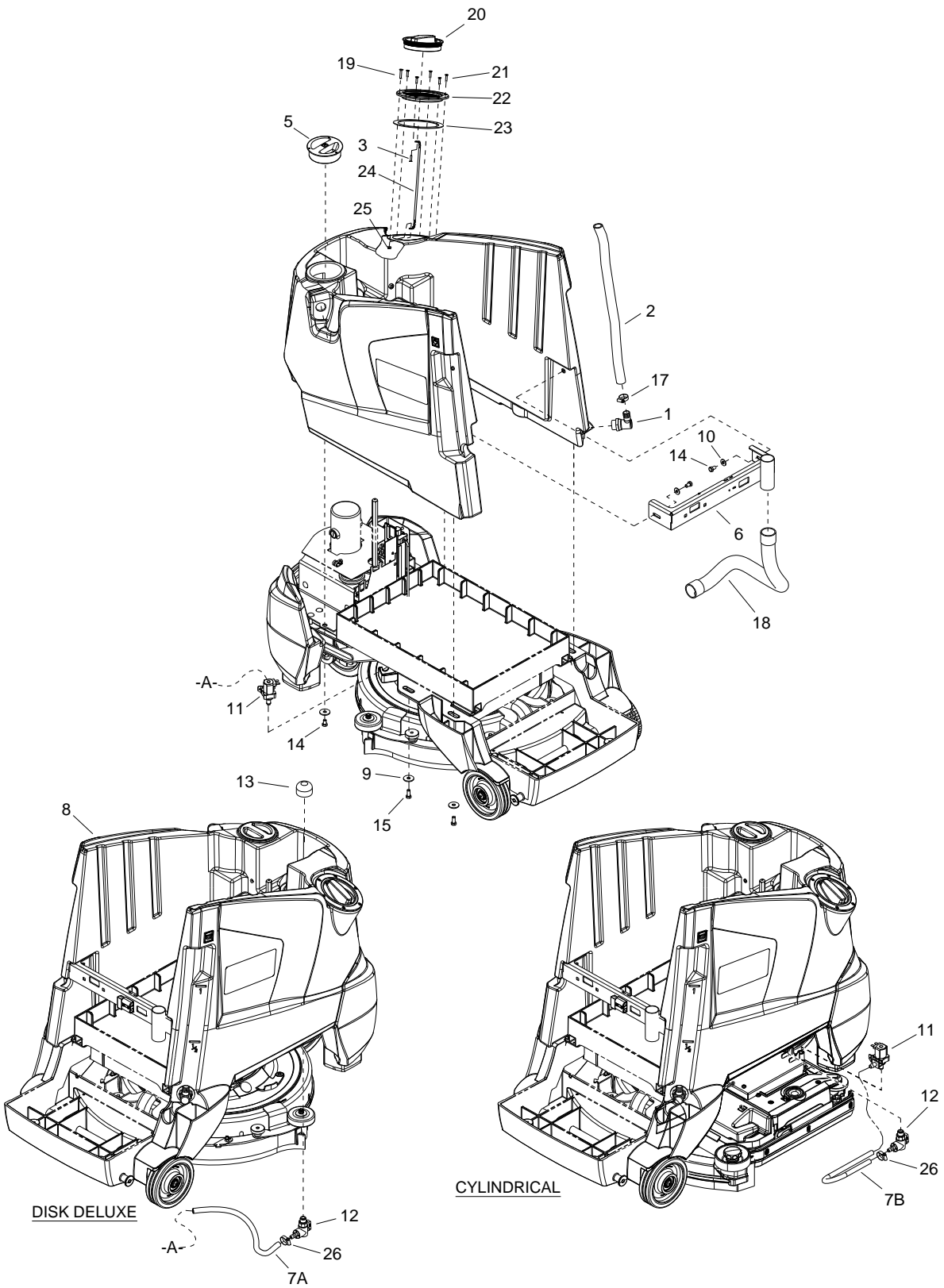

REF	PART NO.	QTY	DESCRIPTION	SERIAL NO. FROM	NOTES
1	86326310	1	FITTING, ELBOW 3/4 BSP, O-RING		
2	86326620	1	HOSE, 3/4ID X .12W X 20"LG, CLR		
3	86327510	1	SCR, KA50 X 16, WN1412 A2 SS		
4	86330940	1	NIPPLE, HEX 3/8NPT X 1.25LG, PE BLACK		
5	50507320	1	COVER METERING FRESH WATER		
6	86326280	1	BRACKET, TANK BRACE		
7A	86321270	1	HOSE, 3/8ID WIREBOUND X 18"		
7B	86281770	1	HOSE, 3/8ID NYLOBRD X 15"		
8	86342820	1	TANK, SOLUTION, CSX20		
9	86279630	5	WASHER, .344IDX1.130ODX.09T PLT		
10	86010670	2	WASHER, 5/16 X 3/4 SS		
11	86362610	1	VALVE, 36VDC SOLENOID	*(16)	
12	86346040	1	VALVE, BALL 3/8MPT X 3/8BARB, 90DEG		
13	86007970	1	STRAINER, 3/8 IN. NPT 60 MESH		
14	86275180	4	SCR, 5/16-18 X 1/2 HHCS GR5		
15	86006760	3	SCR, 5/16-18 X 3/4 HHCS GR5		
16	86001550	1	HOSEBARB, 3/8MPT X 3/8HOSE 90		
17	86233110	1	CLAMP, 1.00 WORM GEAR		
18	86328020	1	HOSE ASM, 1.25 ID X 14.0, 4:1		
19	86339990	1	SCR, 8-32 X 1.0, FHMS, PHLPS, SS, BLK		
20	86314160	1	COVER, FILLPORT 4"		
21	86275800	5	SCREW 8 X 3/4 PFHT/S BLK ZINC		
22	86317620	1	FLANGE, WITH O-RING		
23	86317610	1	GASKET, 5.5 ODX4.5 IDX.06W/PSA		
24	86232790	1	CHAIN,ASM, #10SS BD X 10"		
25	86272020	1	NUT, 8-32 HEX THIN NYLOCK SS		
26	86233150	1	SP CLAMP, 3/8 HOSE (D-SLOT)		

* SEE SERIAL NUMBER PAGE

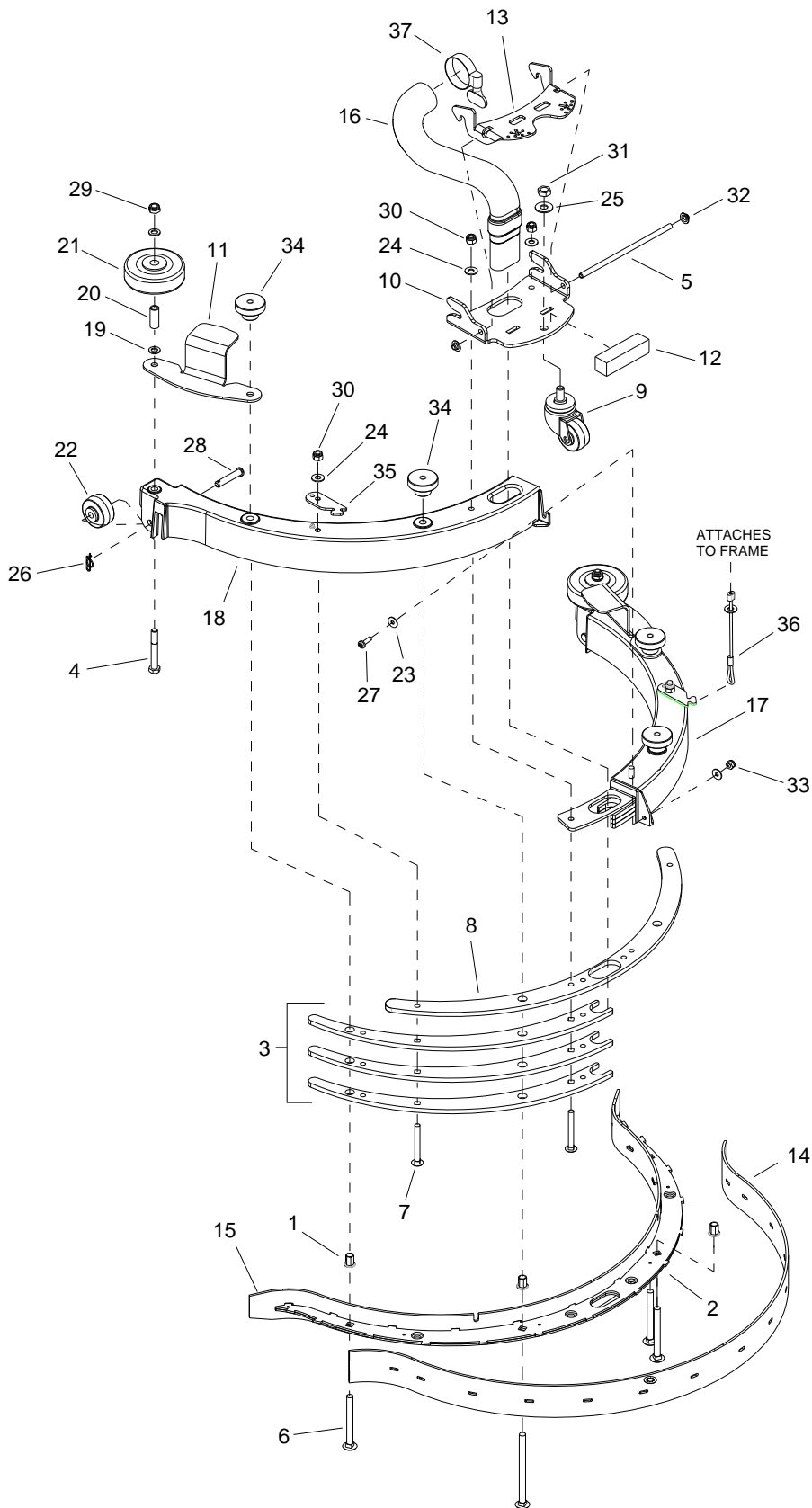

REF	PART NO.	QTY	DESCRIPTION	SERIAL NO. FROM	NOTES
1	86332060	4	RIV-NUT, HEX, 5/16-18X.562, CLEAR CAD		
2	86327860	1	SQUEEGEE BLADE RETAINER ASSY		
3	86327790	6	PLATE, WEIGHT, SQUEEGEE		
4	86326520	2	SCR, 5/16-18 X 2.25 HHCS SS		
5	86326510	1	PIVOT SHAFT, LATCH		
6	86326490	4	SCR, 5/16-18 X 3.0 CARRIAGE SS		
7	86326480	4	SCR, 1/4-20 X 2.25 CARRIAGE SS		
8	86326470	1	BRACE, SQUEEGEE COVER		
9	86326460	1	CASTER, 1-5/8, 3/8-24 SHT STUD		
10	86326450	1	RECEIVER, LATCH PLATE, SQUEEGEE		
11	86326440	2	LIFT BRKT, BUMPER, SQUEEGEE		
12	86326420	1	SPRING, RUBBER		
13	86326400	1	RECEIVER, LATCH, SQUEEGEE		
14	86326070	1	BLADE, SQUEEGEE, REAR, DURO 40		
15	86326060	1	BLADE, SQUEEGEE, FRONT, DURO 40		
-	86342050		BLADE, SQUGE, FRONT, URTHN 38A		OPTION
-	86342060		BLADE, SQUGE, REAR, URTHN 38A		OPTION
16	86323910	1	VACUUM TUBE, SQUEEGEE		
17	86320730	1	COVER, SQUEEGEE-RH		
18	86320720	1	COVER, SQUEEGEE-LH		
19	86292500	4	WASHER, .324ID X .567OD X .057, SS		
20	86001350	2	BUSHING, SPANNER .435 X 1.10		
21	86011020	2	WHEEL, 3" DIA. CUSHION RUBBER		
22	86010880	2	WHEEL, 1.5 OD X .31 ID X .75 W GRY		
23	86010650	2	WASHER, #10 X 9/16 FLAT		
24	86010630	4	WASHER, 1/4 X 5/8 FLAT SS		
25	86278910	1	WASHER, 3/8 X 7/8 FLAT SS		
26	86008660	2	COTTER, 5/16 RING		
27	86275470	1	SCR, 10-32 X 5/8 PPHMS SS		
28	86006270	2	PIN, CLEVIS 5/16 X 1.63 PLTD		
29	86271840	2	NUT, 5/16-18 HEX NYLOCK THN SS		
30	86005810	4	NUT, 1/4-20 HEX NYLOCK SS		
31	86005800	1	NUT, 3/8-24 HEX JAM, PLTD		
32	86271240	2	NUT, CAP, PUSH, .25"		
33	86270990	1	NUT, 10-32 HEX NYLOCK SS		
34	86219690	4	KNOB, 1.5 OD X 5/16-18		
35	86332400	2	LIFT BRKT, DOUBLE SCRUB		
36	86332460	2	LANYARD ASSY, COILED CABLE		
37	86395220	1	CLAMP, 1.75 X .5 WORM GEAR WING SS		
-	86338160	-	SQUEEGEE ASM, CS20 KIT, GUM RUBBER		COMPLETE

Squeegee-Cylindrical

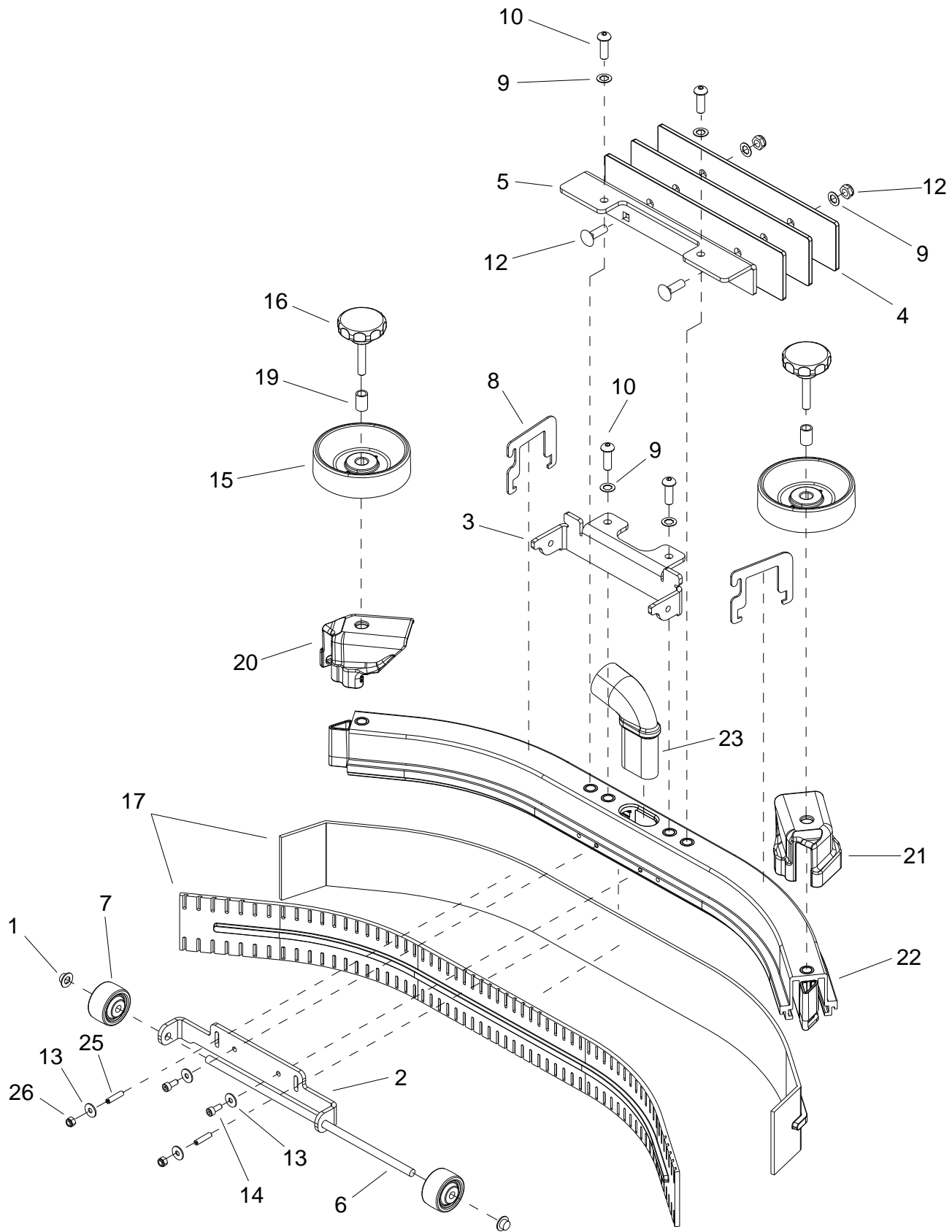

REF	PART NO.	QTY	DESCRIPTION	SERIAL NO. FROM	NOTES
1	86348190	2	NUT, 5/16 PUSH, HAT STYLE, PLTD		
2	86348080	1	BRACKET, CASTER, CYL SQG		
3	86348070	1	BRACKET, LATCH, CYL SQG		
4	86348060	3	PLATE, WEIGHT, CYL SQG		
5	86348050	1	BRACKET, WEIGHT MOUNT		
6	86348040	1	AXLE, CASTER, CYL SQG		
7	86010880	2	WHEEL 1.5OD X .31ID X.75W GRY		
8	86348020	2	BRACKET, DOUBLE SCRUB, CYL SQG		
9	86330990	6	WASHER, 5/16 INT STAR, SS		
10	86329560	4	SCR, M8x1.25x25MM LG, BSHCS, SS		
11	86277130	2	SCR, 5/16-18X1.00 CARRIAGE SS		
12	86271840	2	NUT, 5/16-18 HEX NYLOCK THN SS		
13	86173330	2	WASHER, M5, FLAT, ISO7093, SS		
14	86172950	4	SCR, M5X12, SHCS, ISO4762, SS		
15	55152670	2	WHEEL, BUMPER		
16	63212390	2	STAR GRIP VA Ø50X43		
17	62732940	1	RUBBER LIP SET BR 55/40 RS		
18	-	-	OPEN		
19	50942310	2	SLEEVE SUCTION BAR IN VA		
20	50319910	1	END PIECE RIGHT		
21	50319900	1	END PIECE LEFT		
22	40353100	1	SUCTION BAR PRE-ASSEMBLED CURVED		
23	86346020	1	VACUUM TUBE, SQUEEGEE		
24	86336660	1	GRP, SQUEEGEE ASM. CYL 22IN		COMPLETE
25	86349630	2	SCR, SET, M5 X 25MM, ISO4029, CP, SS		
26	86024750	2	NUT, M5 HEX NYLOCK, SS		

Squeegee Linkage-Cylindrical

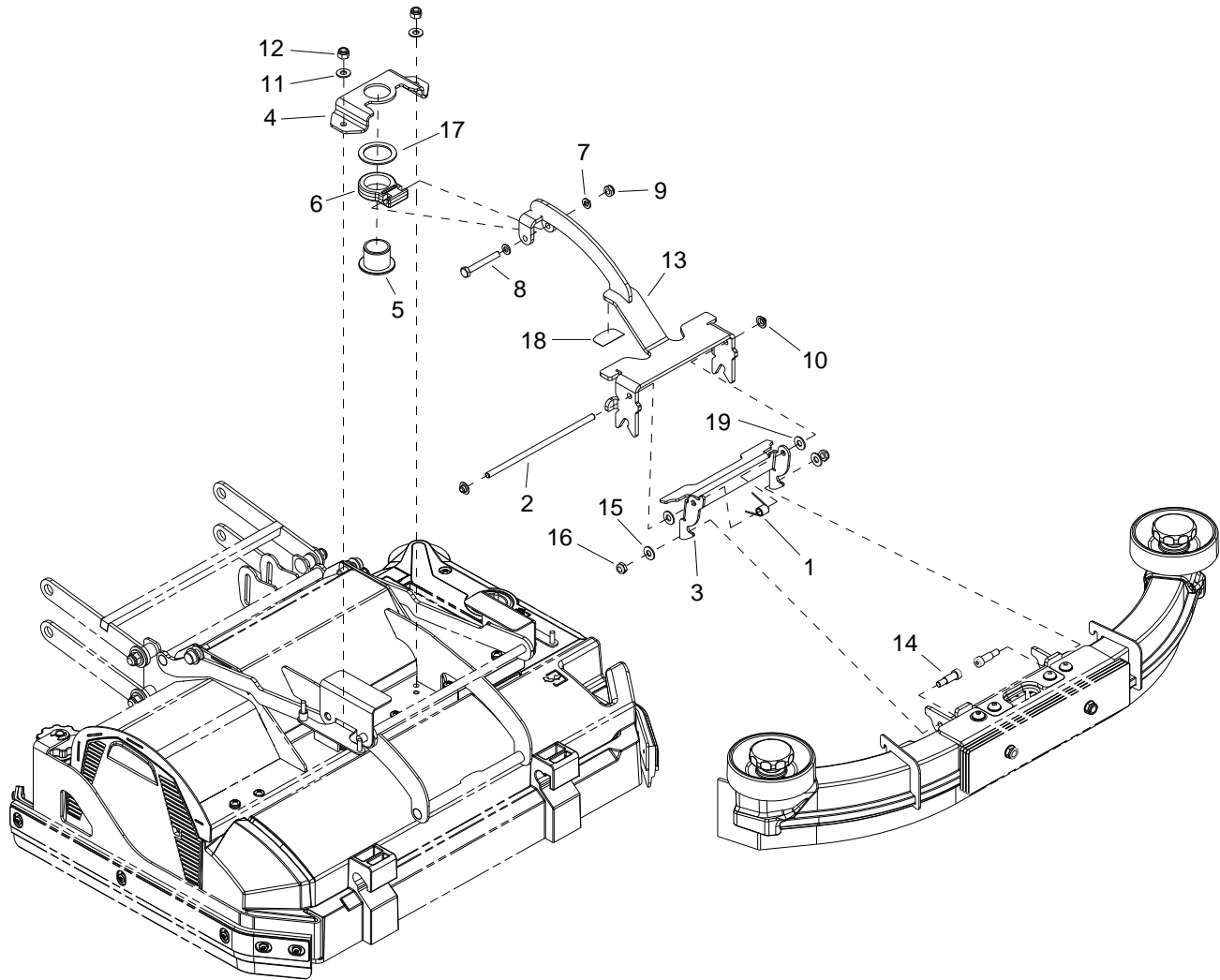

REF	PART NO.	QTY	DESCRIPTION	SERIAL NO FROM	NOTES
1	86347830	1	SPRING, TORSION .048, 180 DEGREE		
2	86346500	1	SHAFT, LATCH, SQUEEGEE		
3	86346480	1	BRACKET, LATCH, SQUEEGEE		
4	86346440	1	BRACKET, SWIVEL MOUNT		
5	86325200	1	BUSHING, 30mm, BRNZ		
6	86319820	1	PIVOT, SQUEEGEE LINKAGE		
7	86279070	2	WASHER, M6 FLAT		
8	86273850	1	SCR, 1/4-20 X 2.00 HHCS SS		
9	86271870	1	NUT, 1/4-20 HEX NYLOCK THIN SS		
10	86271240	2	NUT, CAP, PUSH, .25"		
11	86010630	2	WASHER, 1/4 X 5/8 FLAT SS		
12	86005810	2	NUT, 1/4-20 HEX NYLOCK SS		
13	86347870	1	BRACKET, SQUEEGEE MOUNT		
14	86327700	2	5/16 X 5/8 LG SHOULDER BOLT, SS		
15	86010630	2	WASHER 1/4 ID X 5/8 OD SS		
16	86271870	2	NUT, 1/4-20 HEX NYLCK THIN SS		
17	86348670	1	WASHER, 1.26ID X 1.70OD X .065 THK		
18	86348300	1	WEAR PAD, LIFT, SQGE		
19	86351350	2	WASHER, .260 X .625 X .031, NYL, BLK		

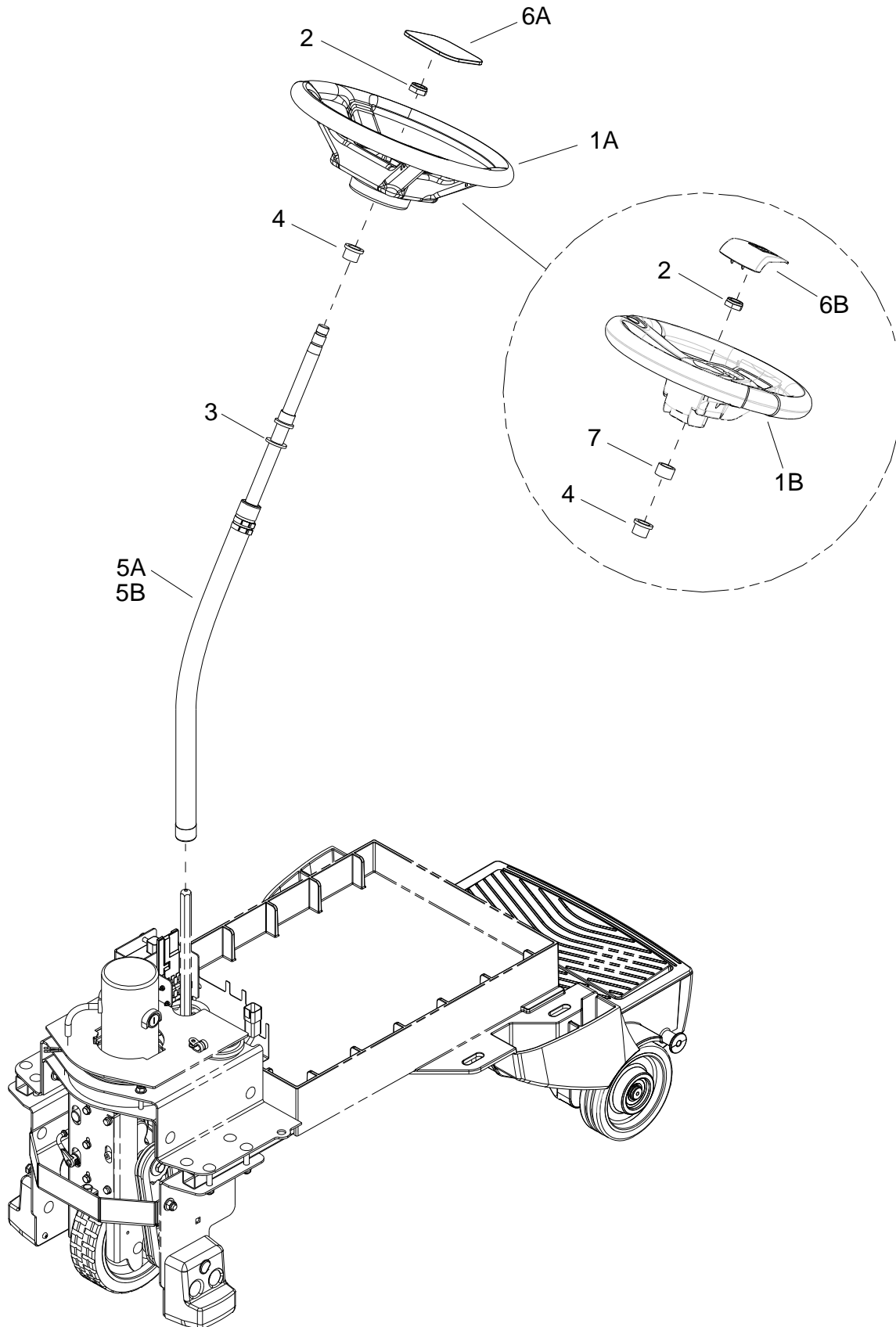

REF	PART NO.	QTY	DESCRIPTION	SERIAL NO. FROM	NOTES
1A	86259610	1	WHEEL STEERING 40 SPLINE HUB		
1B	64357990	1	STEERING WHEEL		DELUXE & CYLINDRICAL
2	86271610	1	NUT 5/8-18 HEX NYLOCK THN		
3	86279420	1	WASHER, .75IDX1.25ODX.125THK NY		
4	86228790	2	BEARING FLANGE .88ODX.75IDX.75		
5A	86339320	1	SHAFT, STEERING KIT CS20		
5B	86339330		SHAFT, STEERING ASM		DELUXE & CYLINDRICAL
6A	86234810	1	COVER, STEERING WHEEL		
6B	66403520	1	CAP STEERING WHEEL WINDSOR		DELUXE & CYLINDRICAL
7	86333950	1	BEARING, .75ID X 1.0OD X .63		DELUXE & CYLINDRICAL

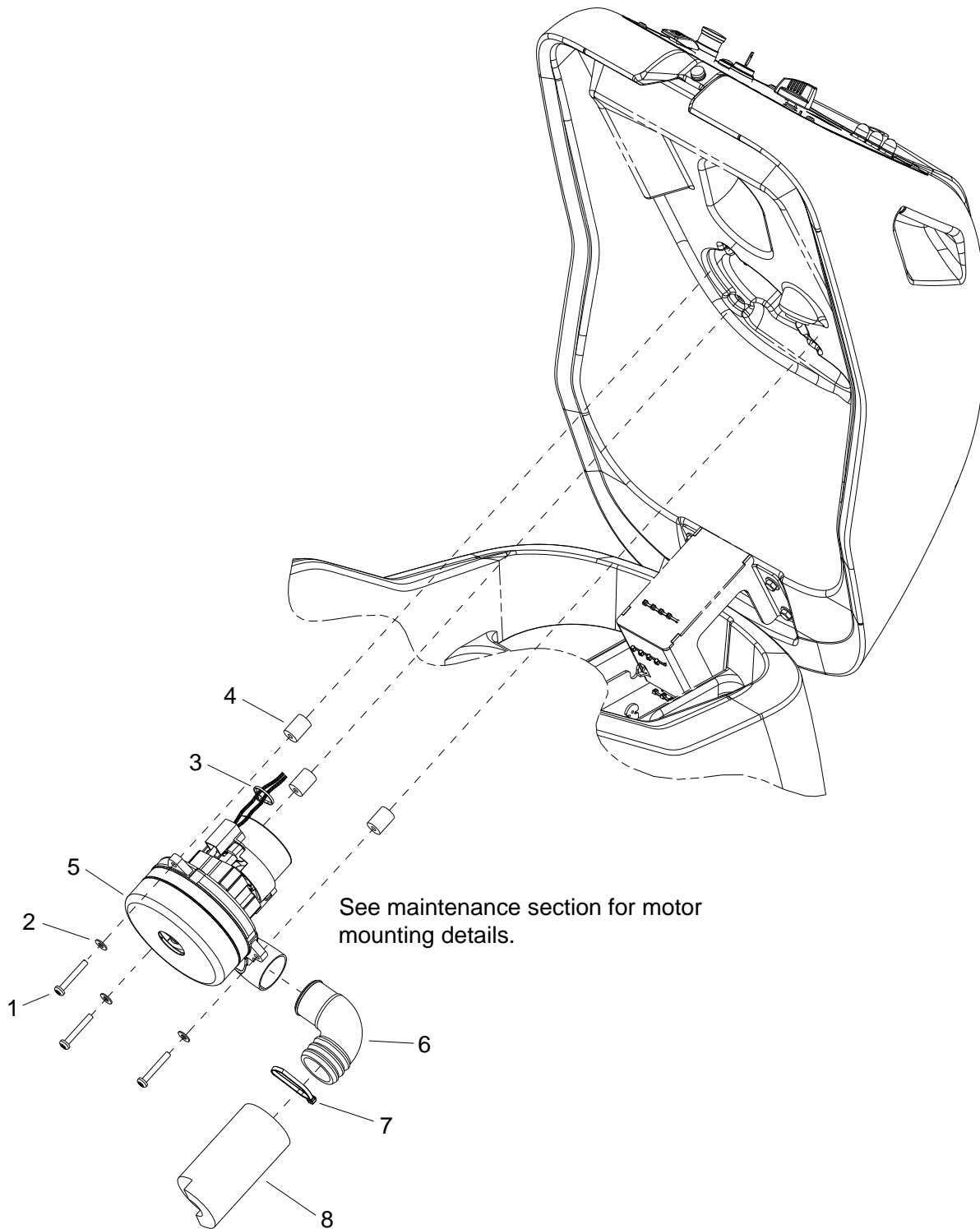

REF	PART NO.	QTY	DESCRIPTION	SERIAL NO. FROM	NOTES
1	86273920	3	SCREW, 1/4-20 X 1.75 PPHMS SS		
2	86010630	3	WASHER 1/4 ID X 5/8 OD SS		
3	86264930	1	CABLE TIE, 3.5" UL/CSA		
4	86327500	3	MOUNT, VIBRATION		
5	86012210	1	VAC MOTOR, 36VDC 2ST TD		
-	86135310	1	BRUSH SET, 24/36V VAC, WINDSOR		
6	86217750	1	ELBOW, VAC MUFFLER 90 DEG		DELUXE ONLY
7	86264940	1	CABLE TIE, 11.38" UL/CSA		DELUXE ONLY
8	86222220	1	MUFFLER, VACUUM FOAM 172		DELUXE ONLY

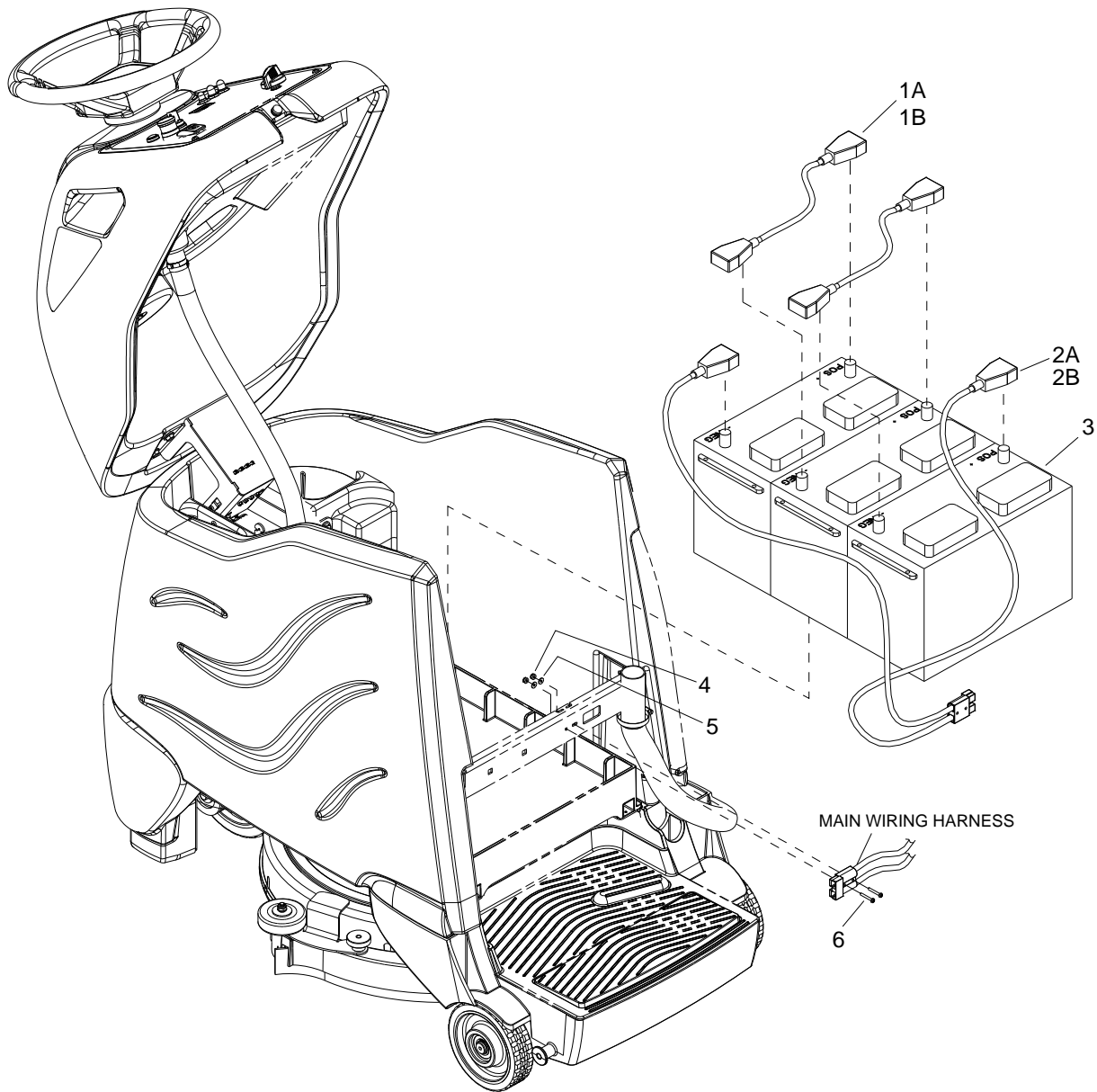

REF	PART NO.	QTY	DESCRIPTION	SERIAL NO. FROM	NOTES
1A	86329720	2	BATT, CBL, ASM, JUMPER		
1B	86334280	2	CBL, 6GA 5/16" RING 15"		NOT SHOWN
2A	86329710	1	BATT,CBL,ASM,W/ANDERSON		
2B	86334270	1	CBL, BATT RING W/ANDERSON		NOT SHOWN
3	86228400	3	BATTERY, 12V, 130AH		
-	86328630	3	BATTERY, 12V 114A/H AGM		NOT SHOWN
4	86270920	2	SP NUT, 6-32 HEX NYLOCK SS		
5	86279450	2	WASHER, #6 FLAT SAE PLTD		
6	86274710	2	SCR, 6-32 X 1.0 PPHMS		
7	86271910	6	NUT, 5/16-18 FLEXLOCK		NOT SHOWN
8	86006560	6	SCREW 5/16-18 X 1 HHCS SS NP		NOT SHOWN

Wiring-Diagram -From Serial No. *(5)

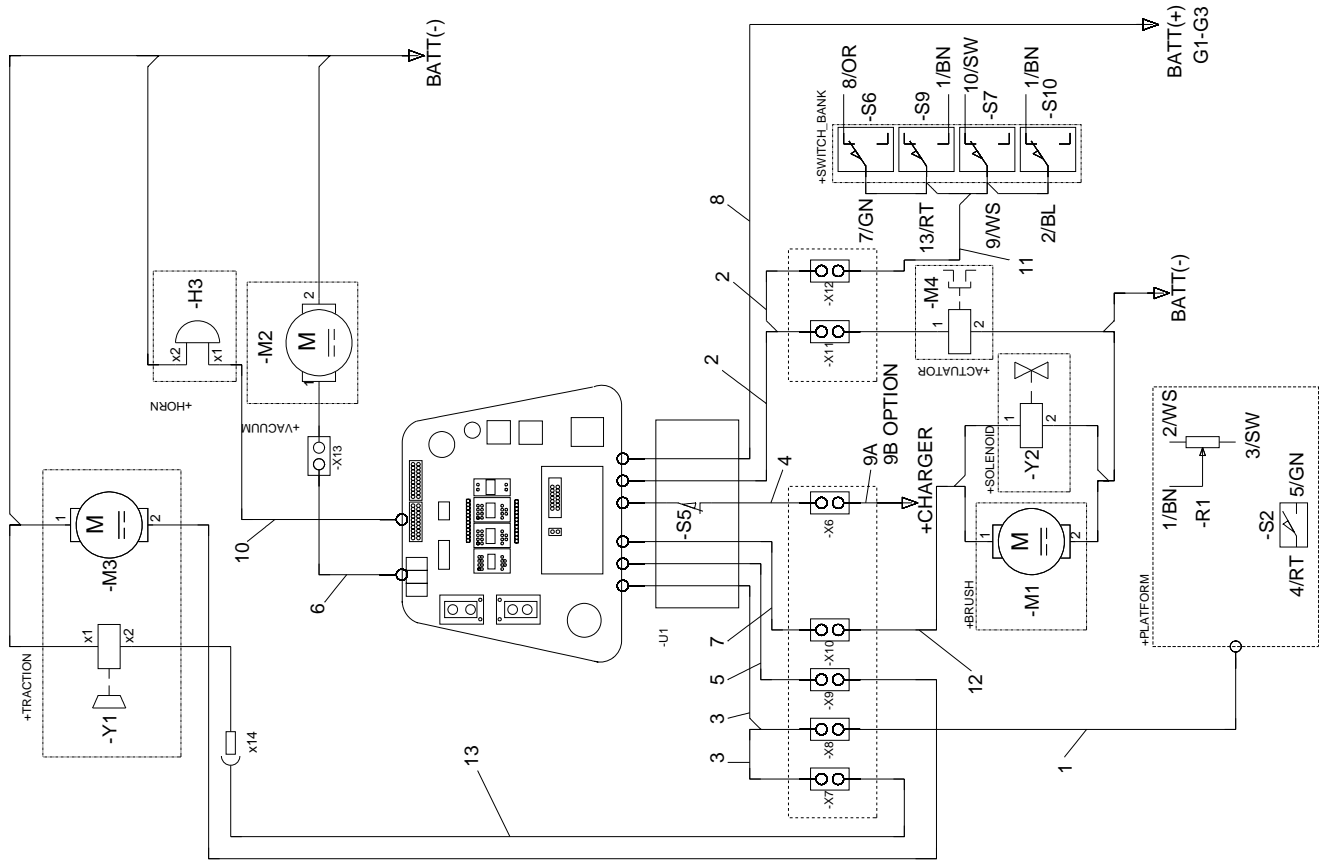

X7		1 - 15/RT 2 - 14/SW
X8		1 - 19/BN 2 - 20/WS 3 - 18/OR 4 - 17/GN 5 - 16/BL 6 - NC
X9		1 - 21/RT 2 - 22/WS
X10		1 - 25/RT 2 - 26/SW
X11		1 - 3/WS 2 - 4/GE
X13		1 - 23/WS 2 - 24/SW
X12		1 - 1/BN 2 - 2/BL 3 - 13/RT 4 - NC 5 - 10/SW 6 - 9/V1 7 - 8/OR 8 - 7/GN
U1		1 - 11/WS 2 - 12/RT
X3	PANEL TB 	5 - 5/RT 6 - 6/SW
X6		11C/SW 12C/RT

REF	PART NO.	QTY	DESCRIPTION	SERIAL NO. FROM	NOTES
1	86326170	1	HARNESS, OPERATOR PLATFORM		
2	86333100	1	HARNESS, CS20 MAIN ACTUATOR		
3	86333110	1	HARNESS, CS20 MAIN POT AND BRAKE		
4	86333120		HARNESS, CS20 MAINCHARGER		
5	86333130	1	HARNESS, CS20 MAIN TRACTION		
6	86333140	1	HARNESS, CS20 MAIN VACUUM		
7	86333150	1	HARNESS, CS20 MAIN BRUSH		
8	86333160	1	HARNESS, CS20 MAIN POWER		
9A	86333180	1	JUMPER, CHARGER INHIBIT		
9B	86332680	1	HARNESS, CHARGER JUMPER		OPTIONAL - BOARD CHARGER
10	86333170	1	HARNESS, CS20 MAIN HORN		
11	86333400	1	HARNESS, CS20 MICRO SWITCH		
12	86346660	1	HARNESS, ROLLER BRUSH		CYLINDRICAL ONLY
13	86362990	1	HARNESS, LOWER BRAKE		

Wiring-Diagram-From Serial No. *(5)

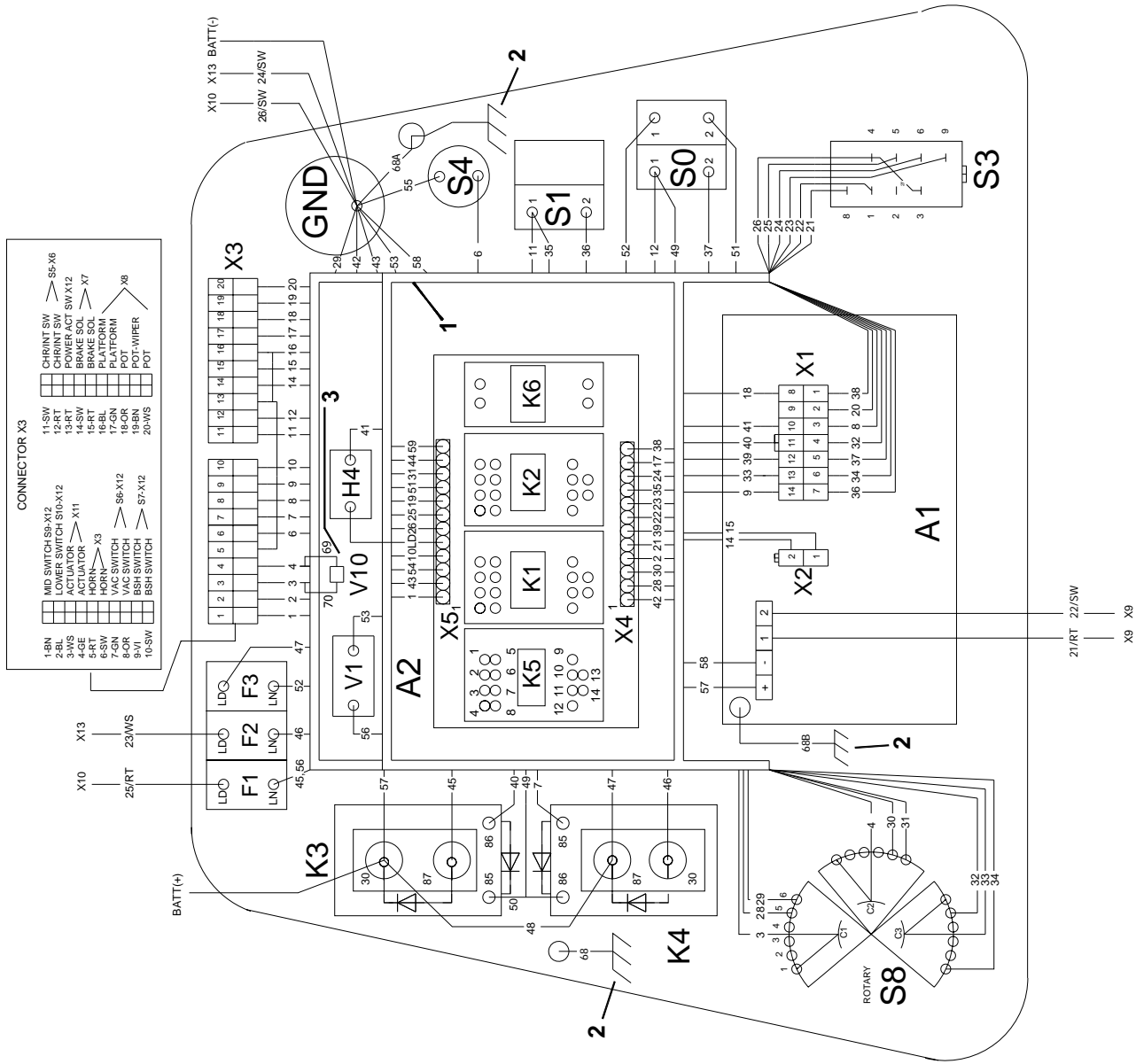

REF	PART NO.	QTY	DESCRIPTION	SERIAL NO. FROM	NOTES
1	86338100	1	HARNESS, PANEL CS20		
2	86352310	1	HARNESS, I-DRIVE GND		
3	86354730	1	DIODE, TVS	(8*)	

REF	DESCRIPTION
F1	CIRCUIT BREAKER-BRUSH
F2	CIRCUIT BREAKER-VACUUM MOTOR
F3	CIRCUIT BREAKER-DRIVE CONTROL
G1-G3	BATTERY 12V/70Ah
H1	SIGNAL LAMPS REVERSE DIRECTION
H2	SIGNAL LAMPS DIRECTION FORWARD
H3	HORN
H4	LED-BATT.
K1	RELAYS-REVERSE DIRECTION
K2	RELAYS DIRECTION FORWARD
K3	RELAYS BRUSH MOTOR
K4	RELAYS VACUUM MOTOR
K5	REALYS ACTUATOR
K6	RELAYS MAIN
M1	BRUSH NMOTOR
M3	TRACTION MOTOR
M4	LINEAR ACTUATOR MOTOR BRUSH/SQUEEGEE
S0	EMERGENCY SWITCH
S1	KEYSWITCH
S2	MICROSWITCH-PLATFORM
S3	BUTTON REVERSE FORWARD
S4	HORN BUTTON
S5	MICROSWITCH-COVER
S6	MIRCOSWITCH-VACUUM
S7	MICROSWITCH-BRUSH
S8	PROGRAM SWITCH
S9	MICROSWITCH-MID
S10	MIRCROSWITCH-LOWER
S11	CHARGER
S-UP-SDOWN	MICROSWITCH
P1	HOURS METER
V1-V2-V3-V4-V5-V6-V7-V8-V9	DIODE
V-UP & V-DOWN	DIODE-MOTOR M4
V10	TVS DIODE
X3	TERMINAL BLOCK
X6-X7-X8-X11-X12	DEUTSCH CONNECTOR
X9-X10-X13	PACKARD CONNECTOR
X14	FASTON TERMINAL
Y1	BRAKE
Y2	ELECTOVALVE WATER

Wiring-Diagram -From Serial No. *(5)

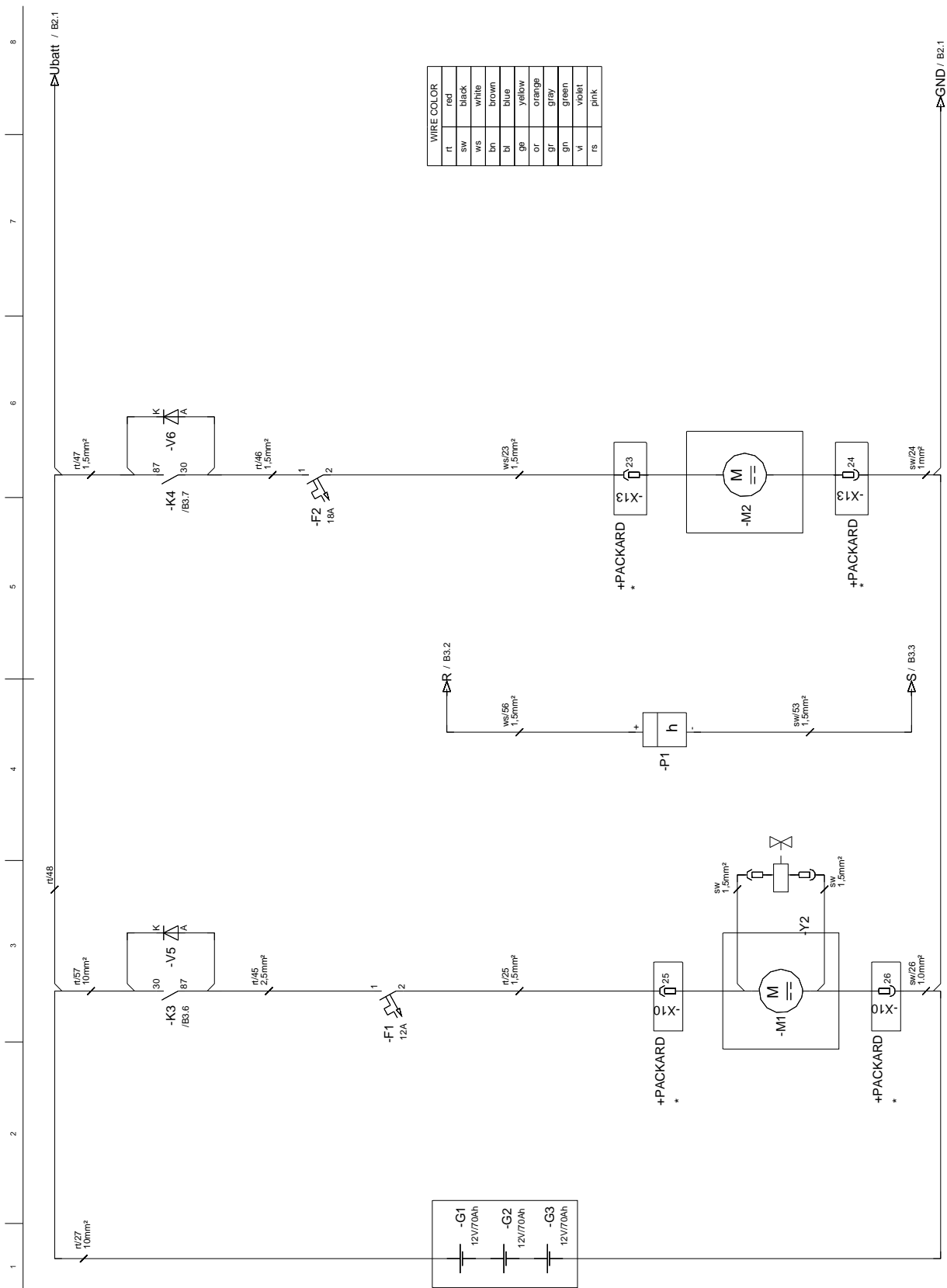

REF	DESCRIPTION
F1	CIRCUIT BREAKER-BRUSH
F2	CIRCUIT BREAKER-VACUUM MOTOR
F3	CIRCUIT BREAKER-DRIVE CONTROL
G1-G3	BATTERY 12V/70Ah
H1	SIGNAL LAMPS REVERSE DIRECTION
H2	SIGNAL LAMPS DIRECTION FORWARD
H3	HORN
H4	LED-BATT.
K1	RELAYS-REVERSE DIRECTION
K2	RELAYS DIRECTION FORWARD
K3	RELAYS BRUSH MOTOR
K4	RELAYS VACUUM MOTOR
K5	REALYS ACTUATOR
K6	RELAYS MAIN
M1	BRUSH NMOTOR
M3	TRACTION MOTOR
M4	LINEAR ACTUATOR MOTOR BRUSH/SQUEEGEE
S0	EMERGENCY SWITCH
S1	KEYSWITCH
S2	MICROSWITCH-PLATFORM
S3	BUTTON REVERSE FORWARD
S4	HORN BUTTON
S5	MICROSWITCH-COVER
S6	MIRCOSWITCH-VACUUM
S7	MICROSWITCH-BRUSH
S8	PROGRAM SWITCH
S9	MICROSWITCH-MID
S10	MIRCROSWITCH-LOWER
S11	CHARGER
S-UP-SDOWN	MICROSWITCH
P1	HOURS METER
V1-V2-V3-V4-V5-V6-V7-V8-V9	DIODE
V-UP & V-DOWN	DIODE-MOTOR M4
V10	TVS DIODE
X3	TERMINAL BLOCK
X6-X7-X8-X11-X12	DEUTSCH CONNECTOR
X9-X10-X13	PACKARD CONNECTOR
X14	FASTON TERMINAL
Y1	BRAKE
Y2	ELECTOVALVE WATER

Wiring-Diagram -From Serial No. *(5)

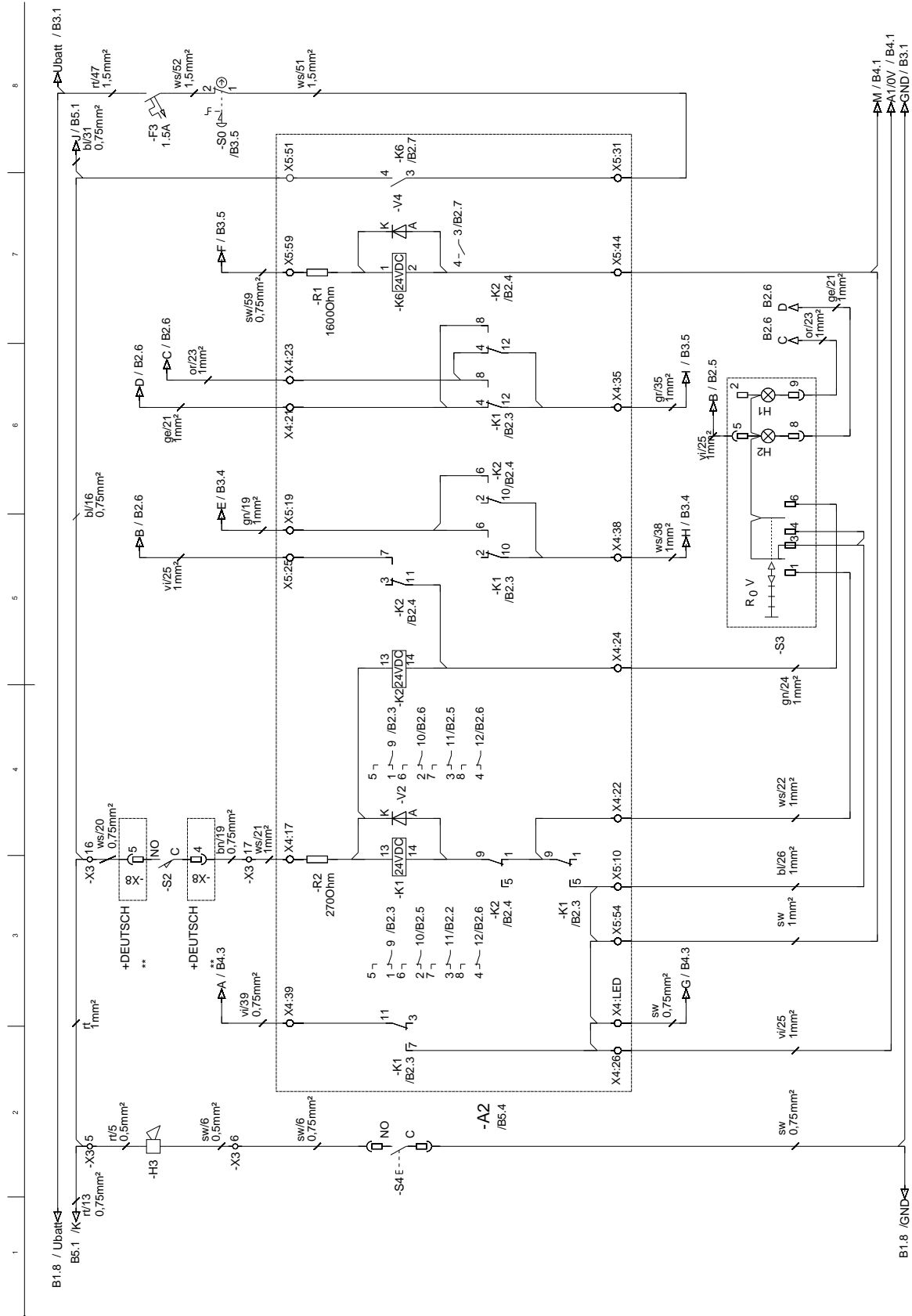

REF	DESCRIPTION
F1	CIRCUIT BREAKER-BRUSH
F2	CIRCUIT BREAKER-VACUUM MOTOR
F3	CIRCUIT BREAKER-DRIVE CONTROL
G1-G3	BATTERY 12V/70Ah
H1	SIGNAL LAMPS REVERSE DIRECTION
H2	SIGNAL LAMPS DIRECTION FORWARD
H3	HORN
H4	LED-BATT.
K1	RELAYS-REVERSE DIRECTION
K2	RELAYS DIRECTION FORWARD
K3	RELAYS BRUSH MOTOR
K4	RELAYS VACUUM MOTOR
K5	REALYS ACTUATOR
K6	RELAYS MAIN
M1	BRUSH NMOTOR
M3	TRACTION MOTOR
M4	LINEAR ACTUATOR MOTOR BRUSH/SQUEEGEE
S0	EMERGENCY SWITCH
S1	KEYSWITCH
S2	MICROSWITCH-PLATFORM
S3	BUTTON REVERSE FORWARD
S4	HORN BUTTON
S5	MICROSWITCH-COVER
S6	MIRCOSWITCH-VACUUM
S7	MICROSWITCH-BRUSH
S8	PROGRAM SWITCH
S9	MICROSWITCH-MID
S10	MIRCROSWITCH-LOWER
S11	CHARGER
S-UP-SDOWN	MICROSWITCH
P1	HOURS METER
V1-V2-V3-V4-V5-V6-V7-V8-V9	DIODE
V-UP & V-DOWN	DIODE-MOTOR M4
V10	TVS DIODE
X3	TERMINAL BLOCK
X6-X7-X8-X11-X12	DEUTSCH CONNECTOR
X9-X10-X13	PACKARD CONNECTOR
X14	FASTON TERMINAL
Y1	BRAKE
Y2	ELECTOVALVE WATER

Wiring-Diagram -From Serial No. *(5)

1 2 3 4 5 6 7 8

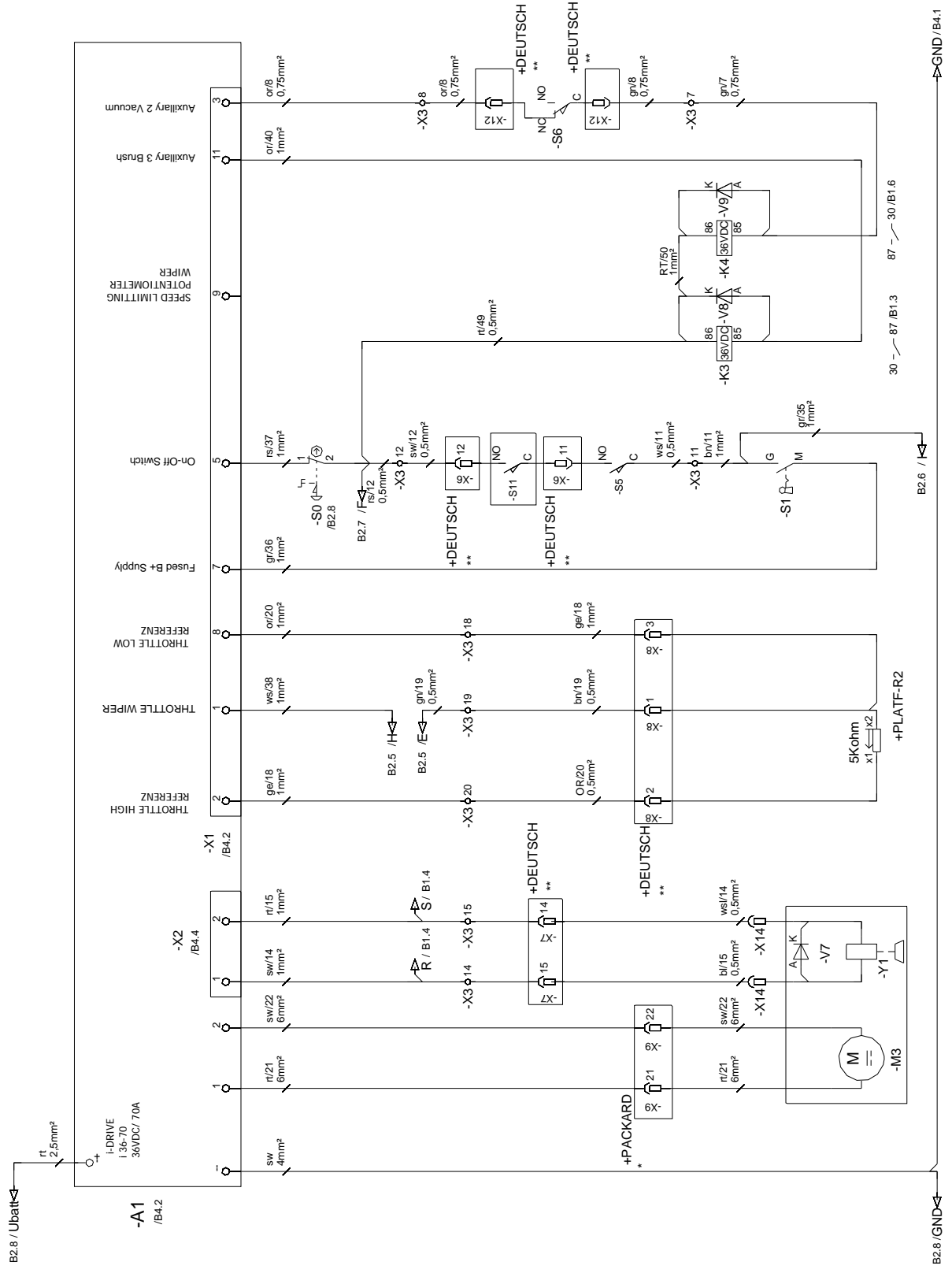

REF	DESCRIPTION
F1	CIRCUIT BREAKER-BRUSH
F2	CIRCUIT BREAKER-VACUUM MOTOR
F3	CIRCUIT BREAKER-DRIVE CONTROL
G1-G3	BATTERY 12V/70Ah
H1	SIGNAL LAMPS REVERSE DIRECTION
H2	SIGNAL LAMPS DIRECTION FORWARD
H3	HORN
H4	LED-BATT.
K1	RELAYS-REVERSE DIRECTION
K2	RELAYS DIRECTION FORWARD
K3	RELAYS BRUSH MOTOR
K4	RELAYS VACUUM MOTOR
K5	REALYS ACTUATOR
K6	RELAYS MAIN
M1	BRUSH NMOTOR
M3	TRACTION MOTOR
M4	LINEAR ACTUATOR MOTOR BRUSH/SQUEEGEE
S0	EMERGENCY SWITCH
S1	KEYSWITCH
S2	MICROSWITCH-PLATFORM
S3	BUTTON REVERSE FORWARD
S4	HORN BUTTON
S5	MICROSWITCH-COVER
S6	MIRCOSWITCH-VACUUM
S7	MICROSWITCH-BRUSH
S8	PROGRAM SWITCH
S9	MICROSWITCH-MID
S10	MIRCROSWITCH-LOWER
S11	CHARGER
S-UP-SDOWN	MICROSWITCH
P1	HOURS METER
V1-V2-V3-V4-V5-V6-V7-V8-V9	DIODE
V-UP & V-DOWN	DIODE-MOTOR M4
V10	TVS DIODE
X3	TERMINAL BLOCK
X6-X7-X8-X11-X12	DEUTSCH CONNECTOR
X9-X10-X13	PACKARD CONNECTOR
X14	FASTON TERMINAL
Y1	BRAKE
Y2	ELECTOVALVE WATER

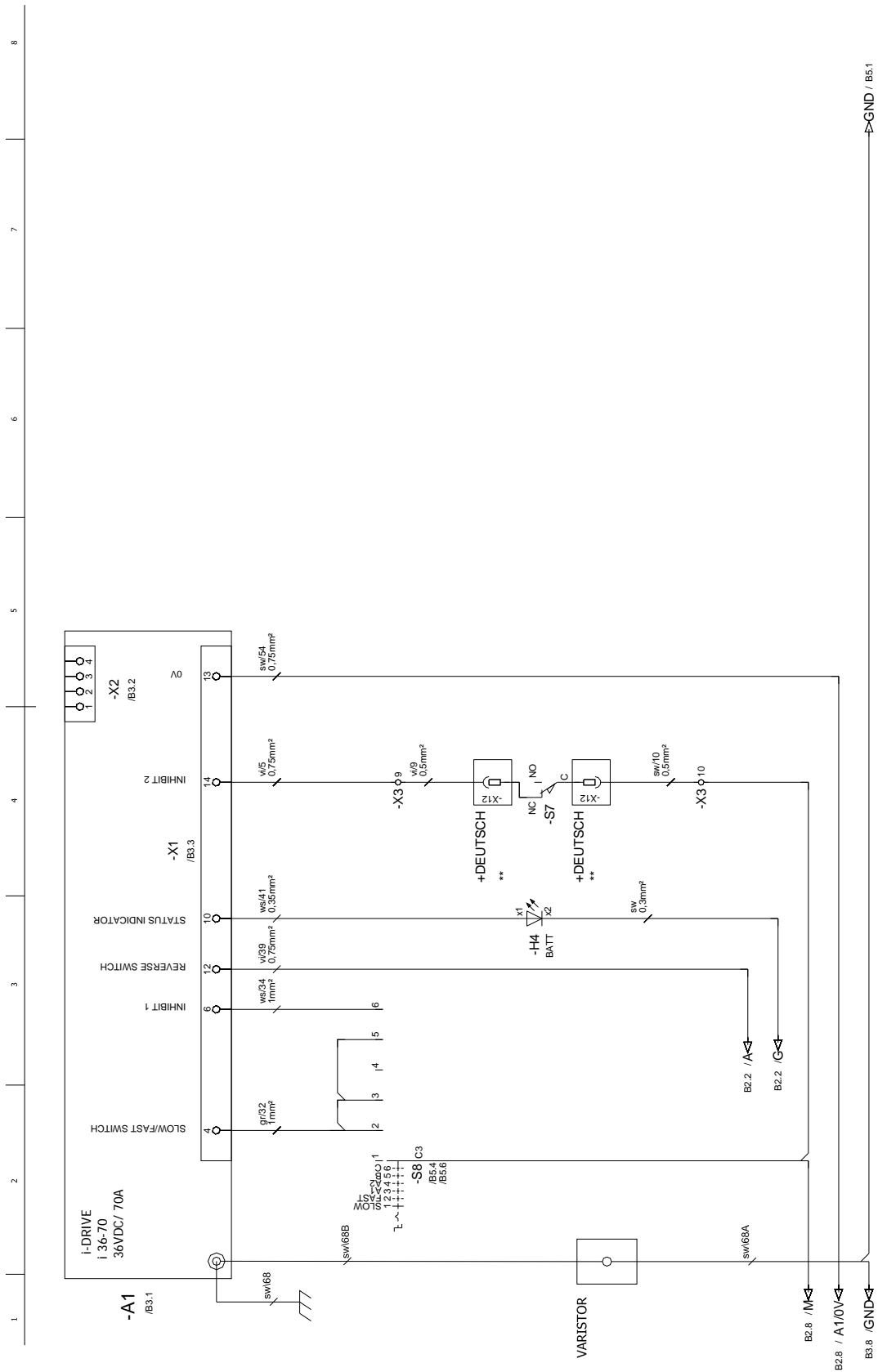

REF	DESCRIPTION
F1	CIRCUIT BREAKER-BRUSH
F2	CIRCUIT BREAKER-VACUUM MOTOR
F3	CIRCUIT BREAKER-DRIVE CONTROL
G1-G3	BATTERY 12V/70Ah
H1	SIGNAL LAMPS REVERSE DIRECTION
H2	SIGNAL LAMPS DIRECTION FORWARD
H3	HORN
H4	LED-BATT.
K1	RELAYS-REVERSE DIRECTION
K2	RELAYS DIRECTION FORWARD
K3	RELAYS BRUSH MOTOR
K4	RELAYS VACUUM MOTOR
K5	REALYS ACTUATOR
K6	RELAYS MAIN
M1	BRUSH NMOTOR
M3	TRACTION MOTOR
M4	LINEAR ACTUATOR MOTOR BRUSH/SQUEEGEE
S0	EMERGENCY SWITCH
S1	KEYSWITCH
S2	MICROSWITCH-PLATFORM
S3	BUTTON REVERSE FORWARD
S4	HORN BUTTON
S5	MICROSWITCH-COVER
S6	MIRCOSWITCH-VACUUM
S7	MICROSWITCH-BRUSH
S8	PROGRAM SWITCH
S9	MICROSWITCH-MID
S10	MIRCROSWITCH-LOWER
S11	CHARGER
S-UP-SDOWN	MICROSWITCH
P1	HOURS METER
V1-V2-V3-V4-V5-V6-V7-V8-V9	DIODE
V-UP & V-DOWN	DIODE-MOTOR M4
V10	TVS DIODE
X3	TERMINAL BLOCK
X6-X7-X8-X11-X12	DEUTSCH CONNECTOR
X9-X10-X13	PACKARD CONNECTOR
X14	FASTON TERMINAL
Y1	BRAKE
Y2	ELECTOVALVE WATER

Wiring-Diagram -From Serial No. *(5)

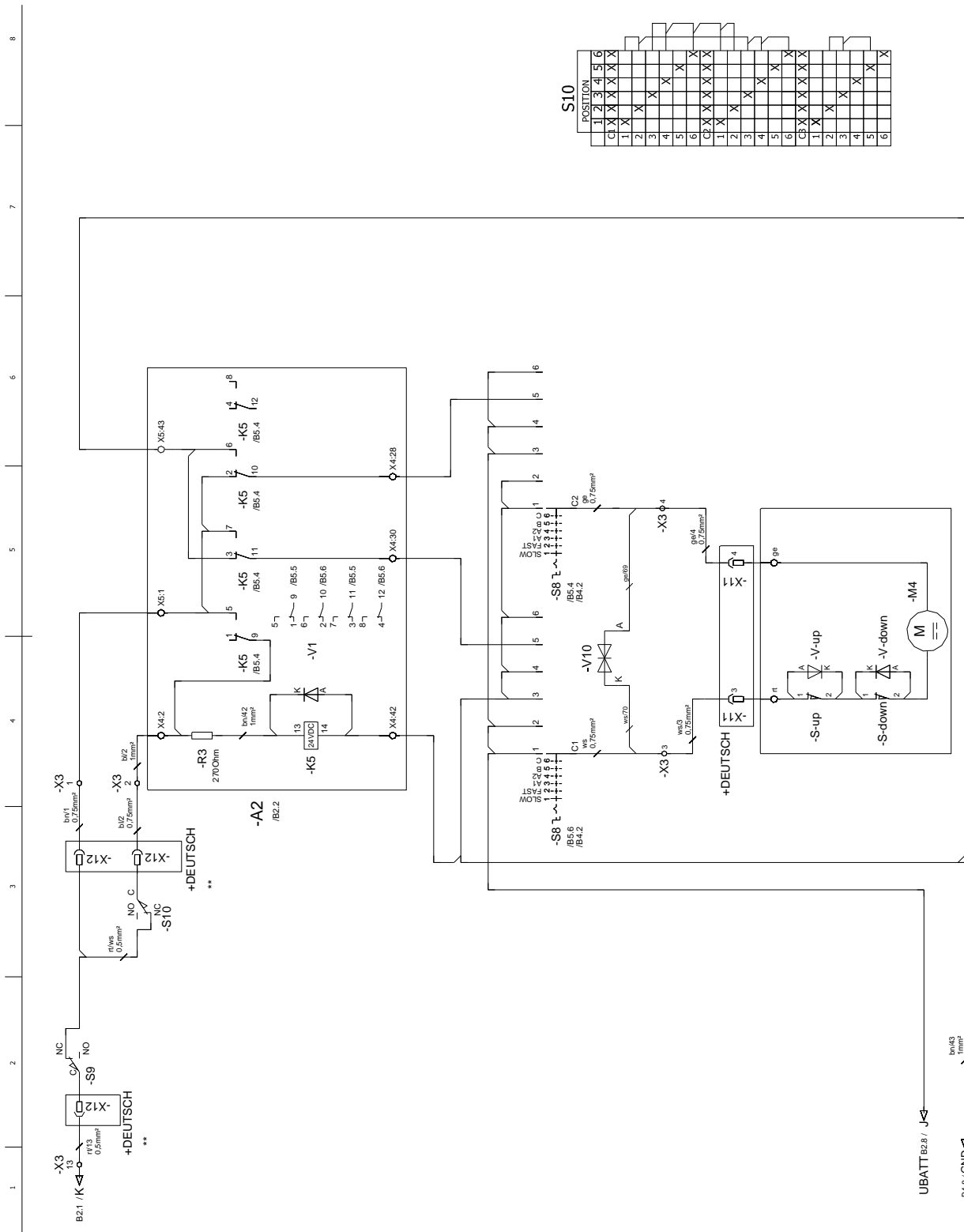

S10

POSITION	1	2	3	4	5	6
C1	X	X	X	X	X	X
1	X					
2		X				
3			X			
4				X		
5					X	
6						X
C2	X	X	X	X	X	X
1	X					
2		X				
3			X			
4				X		
5					X	
6						X
C3	X	X	X	X	X	X
1	X					
2		X				
3			X			
4				X		
5					X	
6						X

REF	DESCRIPTION
F1	CIRCUIT BREAKER-BRUSH
F2	CIRCUIT BREAKER-VACUUM MOTOR
F3	CIRCUIT BREAKER-DRIVE CONTROL
G1-G3	BATTERY 12V/70Ah
H1	SIGNAL LAMPS REVERSE DIRECTION
H2	SIGNAL LAMPS DIRECTION FORWARD
H3	HORN
H4	LED-BATT.
K1	RELAYS-REVERSE DIRECTION
K2	RELAYS DIRECTION FORWARD
K3	RELAYS BRUSH MOTOR
K4	RELAYS VACUUM MOTOR
K5	REALYS ACTUATOR
K6	RELAYS MAIN
M1	BRUSH NMOTOR
M3	TRACTION MOTOR
M4	LINEAR ACTUATOR MOTOR BRUSH/SQUEEGEE
S0	EMERGENCY SWITCH
S1	KEYSWITCH
S2	MICROSWITCH-PLATFORM
S3	BUTTON REVERSE FORWARD
S4	HORN BUTTON
S5	MICROSWITCH-COVER
S6	MIRCOSWITCH-VACUUM
S7	MICROSWITCH-BRUSH
S8	PROGRAM SWITCH
S9	MICROSWITCH-MID
S10	MIRCROSWITCH-LOWER
S11	CHARGER
S-UP-SDOWN	MICROSWITCH
P1	HOURS METER
V1-V2-V3-V4-V5-V6-V7-V8-V9	DIODE
V-UP & V-DOWN	DIODE-MOTOR M4
V10	TVS DIODE
X3	TERMINAL BLOCK
X6-X7-X8-X11-X12	DEUTSCH CONNECTOR
X9-X10-X13	PACKARD CONNECTOR
X14	FASTON TERMINAL
Y1	BRAKE
Y2	ELECTOVALVE WATER

FRONT

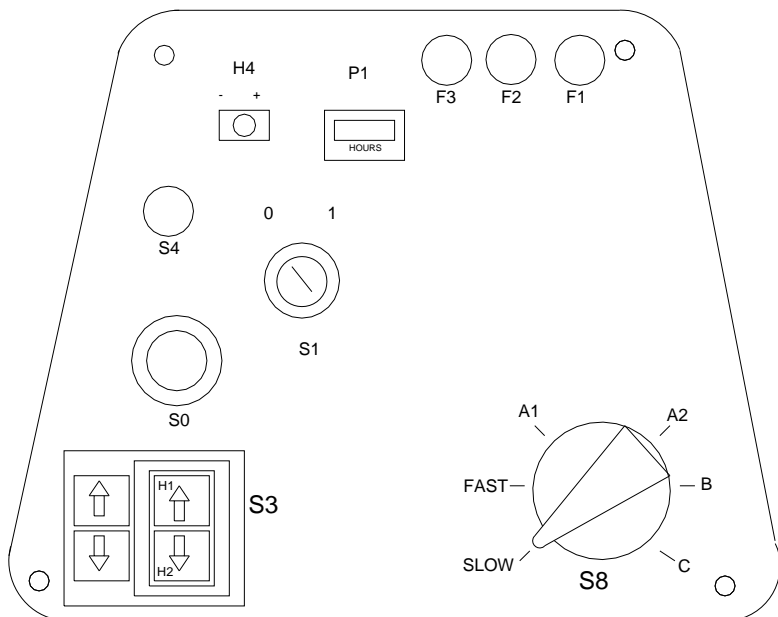

BACK

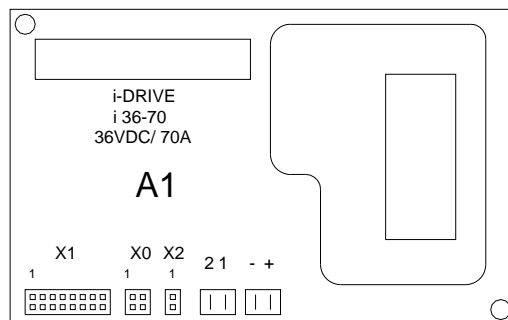
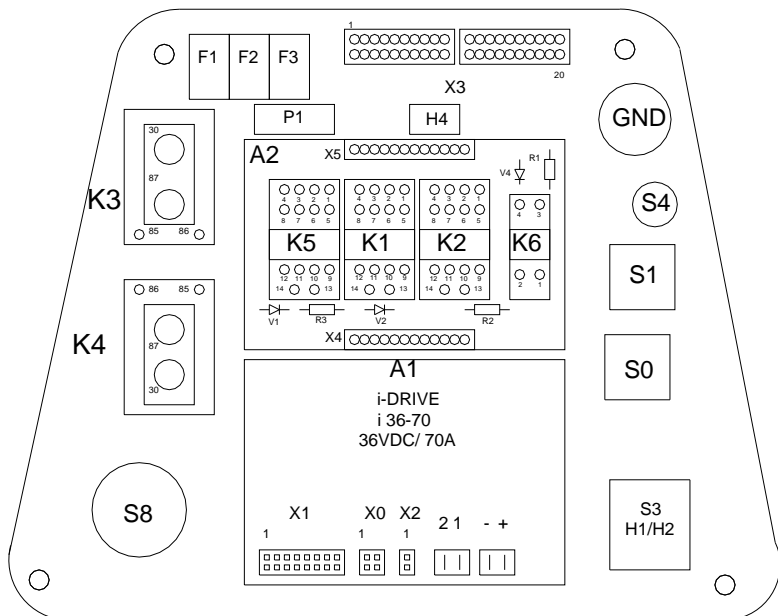

REF	DESCRIPTION
F1	CIRCUIT BREAKER-BRUSH
F2	CIRCUIT BREAKER-VACUUM MOTOR
F3	CIRCUIT BREAKER-DRIVE CONTROL
G1-G3	BATTERY 12V/70Ah
H1	SIGNAL LAMPS REVERSE DIRECTION
H2	SIGNAL LAMPS DIRECTION FORWARD
H3	HORN
H4	LED-BATT.
K1	RELAYS-REVERSE DIRECTION
K2	RELAYS DIRECTION FORWARD
K3	RELAYS BRUSH MOTOR
K4	RELAYS VACUUM MOTOR
K5	REALYS ACTUATOR
K6	RELAYS MAIN
M1	BRUSH NMOTOR
M3	TRACTION MOTOR
M4	LINEAR ACTUATOR MOTOR BRUSH/SQUEEGEE
S0	EMERGENCY SWITCH
S1	KEYSWITCH
S2	MICROSWITCH-PLATFORM
S3	BUTTON REVERSE FORWARD
S4	HORN BUTTON
S5	MICROSWITCH-COVER
S6	MIRCOSWITCH-VACUUM
S7	MICROSWITCH-BRUSH
S8	PROGRAM SWITCH
S9	MICROSWITCH-MID
S10	MIRCROSWITCH-LOWER
S11	CHARGER
S-UP-SDOWN	MICROSWITCH
P1	HOURS METER
V1-V2-V3-V4-V5-V6-V7-V8-V9	DIODE
V-UP & V-DOWN	DIODE-MOTOR M4
V10	TVS DIODE
X3	TERMINAL BLOCK
X6-X7-X8-X11-X12	DEUTSCH CONNECTOR
X9-X10-X13	PACKARD CONNECTOR
X14	FASTON TERMINAL
Y1	BRAKE
Y2	ELECTOVALVE WATER

Wiring-Control Panel -Prior to Serial No. *(5)

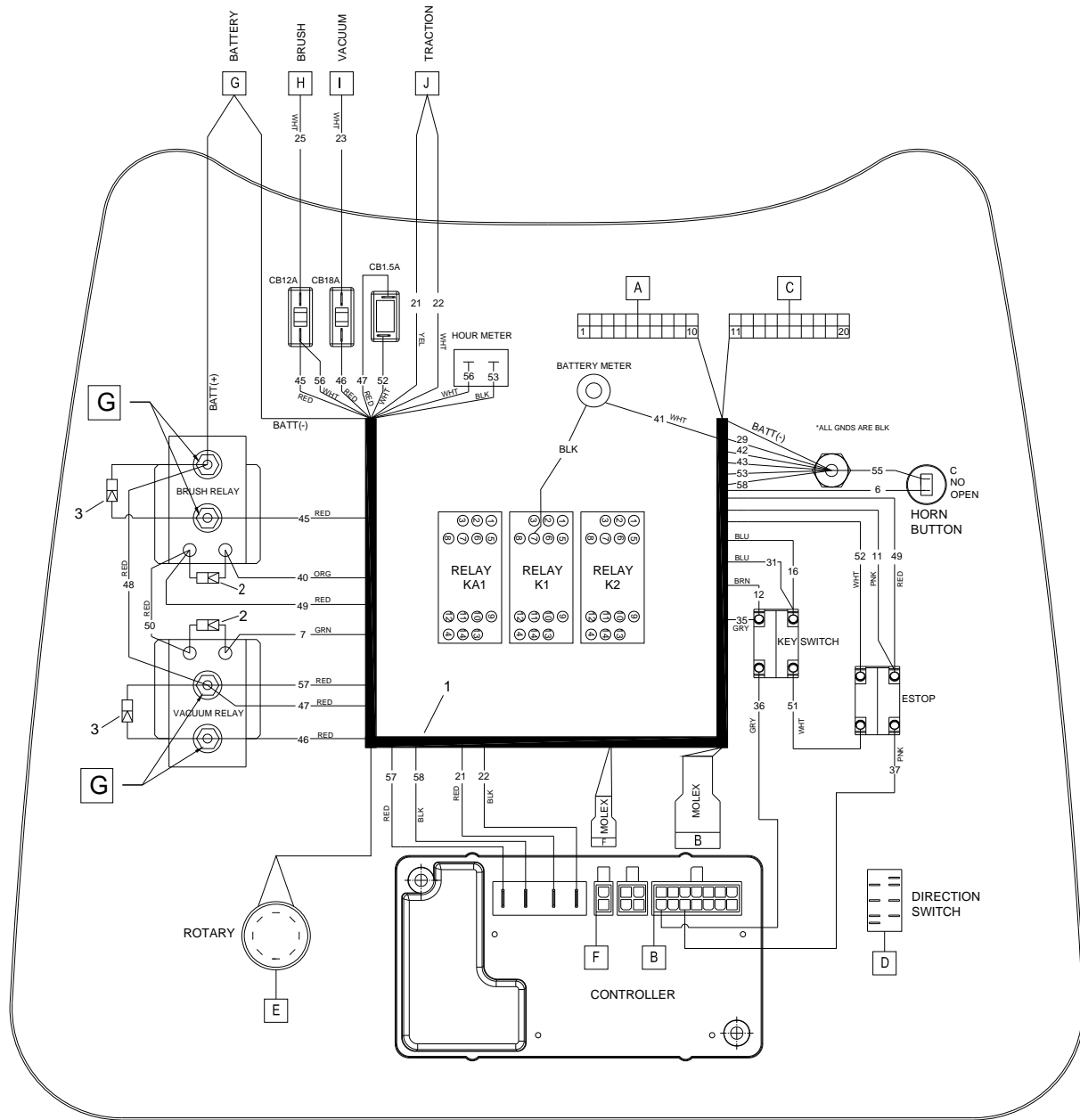

RELAY JUMPERS	
PIN 5 K1-PIN 7 K1	
PIN 6 K1-PIN 8 K2	
PIN 8 K1-PIN 4 K2	
PIN 9 K1-PIN 1 K2	
PIN 4 K1-PIN 8 K2	
PIN 10 K1-PIN 10 K2	
PIN 12 K1-PIN 12 K2	
PIN 13 K1-PIN 13 K2	
PIN 14 K1-PIN 9 K2	
PIN 11 K2-PIN 14 K2	
RELAY JUMPERS	
PIN 2 KA1-PIN 7 KA1	
PIN 3 KA1-PIN 6 KA1	
PIN 2 KA1-PIN 5 KA1	
RESISTOR 270OHM 5W	
PIN 9 KA1-PIN 13 KA1	
PIN 13 K2-PIN 17 TB	

CONNECTOR A	
1-BRN	MID SWITCH S1
2-BLU	LOWER SWITCH S2
3-WHT	ACTUATOR
4-YEL	ACTUATOR
5-RED	HORN
6-BLK	HORN
7-GRN	VAC SWITCH
8-ORG	VAC SWITCH
9-VIO	BSH SWITCH
10-BLK	BSH SWITCH

CONNECTOR B	
PIN 1 - 38-WHT	
PIN 2 - 18-YEL	
PIN 3 - 8-ORG	
PIN 4 - 32-GRY	
PIN 5 - 37-PNK	
PIN 6 - 34-WHT	
PIN 7 - 36-GRY	
PIN 8 - 20-ORG	
PIN 10 - 41-YEL	
PIN 11 - 40-ORG	
PIN 12 - 39-VIO	
PIN 13 - 33-BLK	
PIN 14 - 9-VIO	

CONNECTOR C	
11-BLK	CHR/INT SWITCH
12-RED	CHR/INT SWITCH
13-RED	POWER ACT SWITCHES
14-BLK	BRAKE SOL
15-RED	BRAKE SOL
16-BLU	PLATFORM
17-GRN	PLATFORM
18-ORG	POT
19-BRN	POT-WIPER
20-WHT	POT

CONNECTOR D	
S1 - PIN 9 K1 / 22-WHT	
S2 - OPEN	
S3 - S4 / 27-BLK	
S4 - PIN 5 K1 / 26-BLU	
S5 - PIN 7 K2 / 25-VIO	
S6 - PIN 14 K2 / 24-GRN	
S8 - PIN 4 K1 / 21-YEL	
S9 - PIN 4 K2 / 23-ORG	

CONNECTOR E	
ROTARY JUMPERS	
C1-1 TO C1-2	
C1-2 TO C2-3	
C2-3 TO C2-4	
C2-4 TO C2-6	
C2-1 TO C2-2	
C2-2 TO C1-3	
C1-3 TO C1-4	
C1-4 TO C1-6	
C3-2 TO C3-3	
C3-3 TO C3-5	

CONNECTOR F	
2	PIN 2 - BRAKE NEGATIVE
1	PIN 1 - BRAKE POSITIVE

G TORQUE 45-55 IN-LBS

REF	PART NO.	QTY	DESCRIPTION	SERIAL NO. FROM	NOTES
1	86326190	1	HARNESS, MAIN PANEL		
2	86261210	2	DIODE ASM, 76008 X 76008		
3	86003410	2	DIODE ASM, 76075 X 76075		

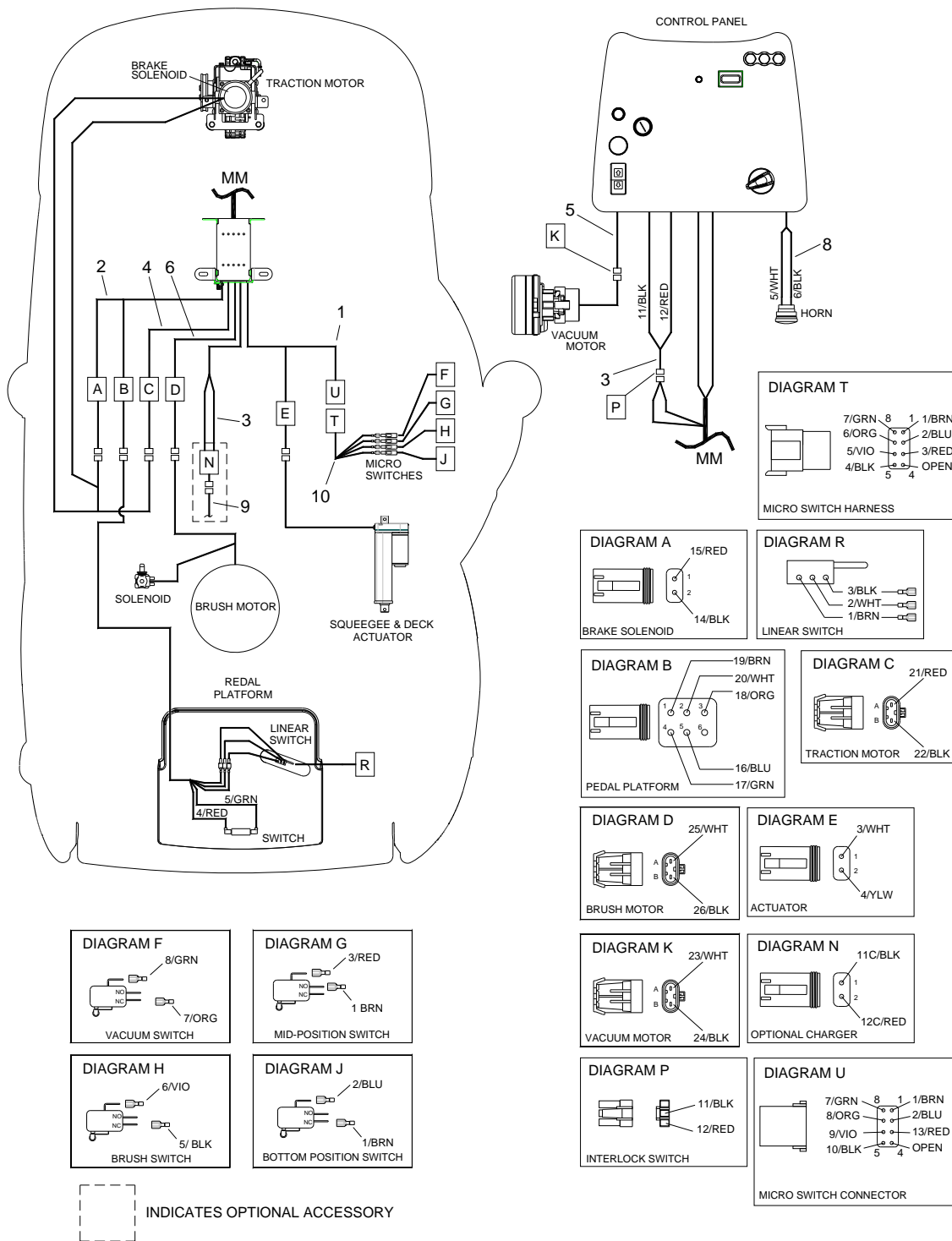

REF	PART NO.	QTY	DESCRIPTION	SERIAL NO. FROM	NOTES
1	86333100	1	HARNESS, CS20 MAIN ACTUATOR		
2	86333110	1	HARNESS, CS20 MAIN POT AND BRAKE		
3	86333120	1	HARNESS, CS20 MAIN CHARGER		
4	86333130	1	HARNESS, CS20 MAIN TRACTION		
5	86333140	1	HARNESS, CS20 MAIN VACUUM		
6	86333150	1	HARNESS, CS20 MAIN BRUSH		
7	86333160	1	HARNESS, CS20 MAIN POWER		
8	86333170	1	HARNESS, CS20 MAIN HORN		
9	86333180	1	JUMPER, CHARGER INHIBIT		
10	86333400	1	HARNESS, CS20 MICRO SWITCH		

Wiring-Diagram -Prior to Serial No. *(5)

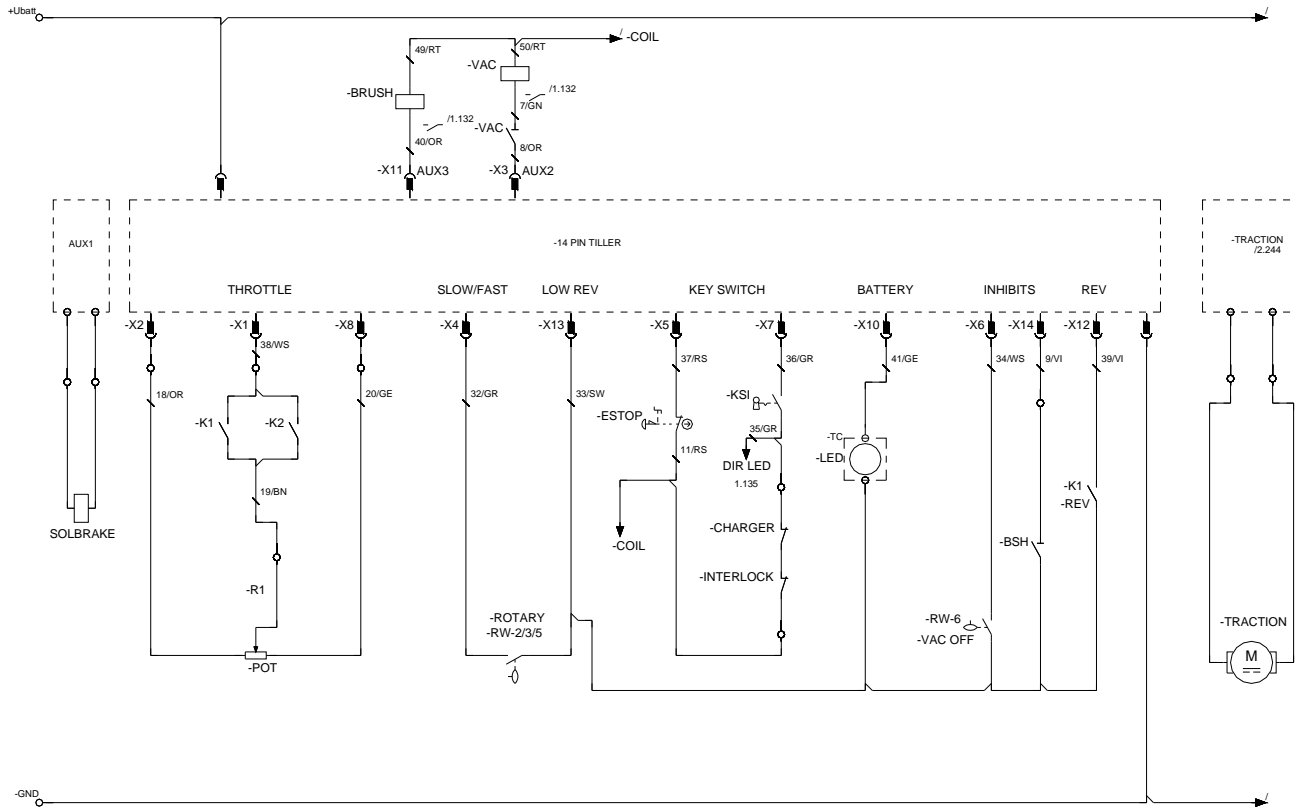

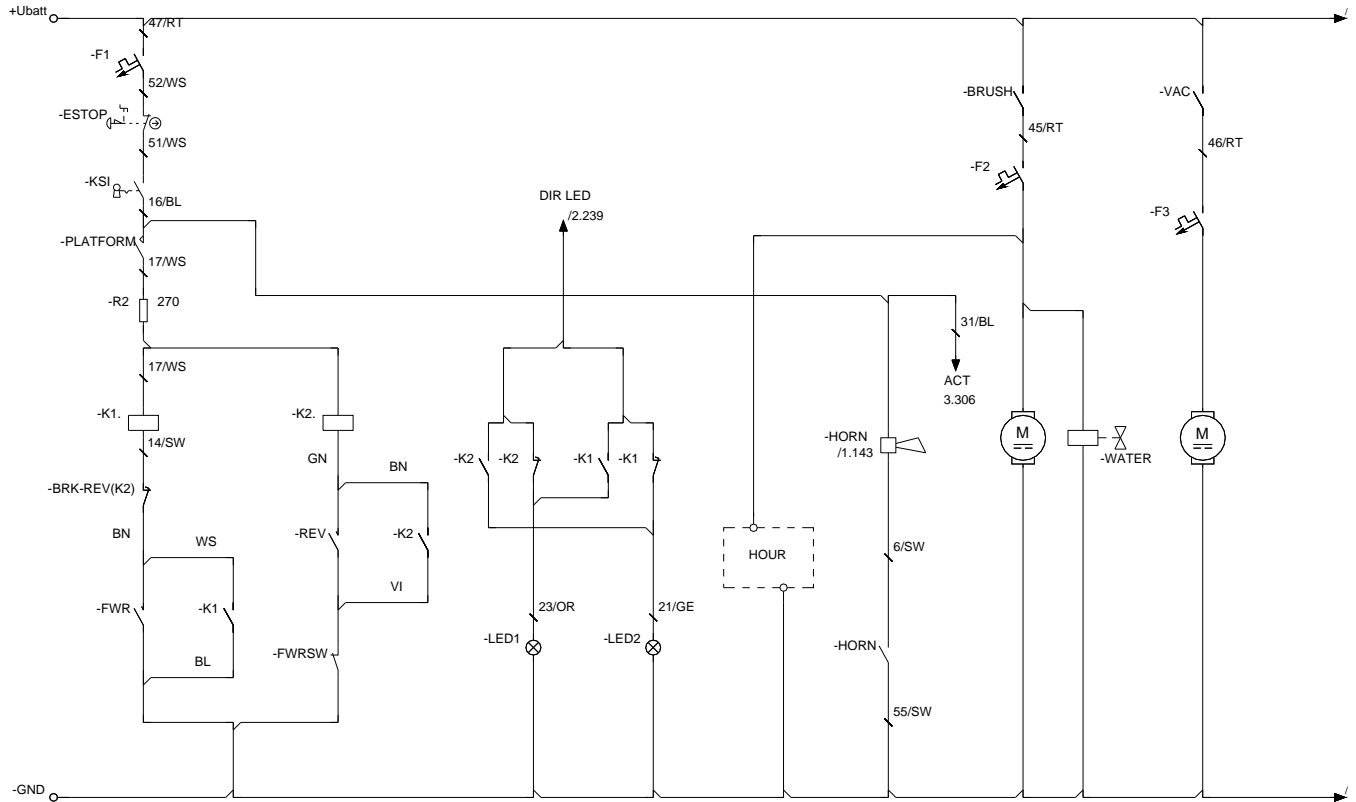

Wiring-Diagram -Prior to Serial No. *(5)

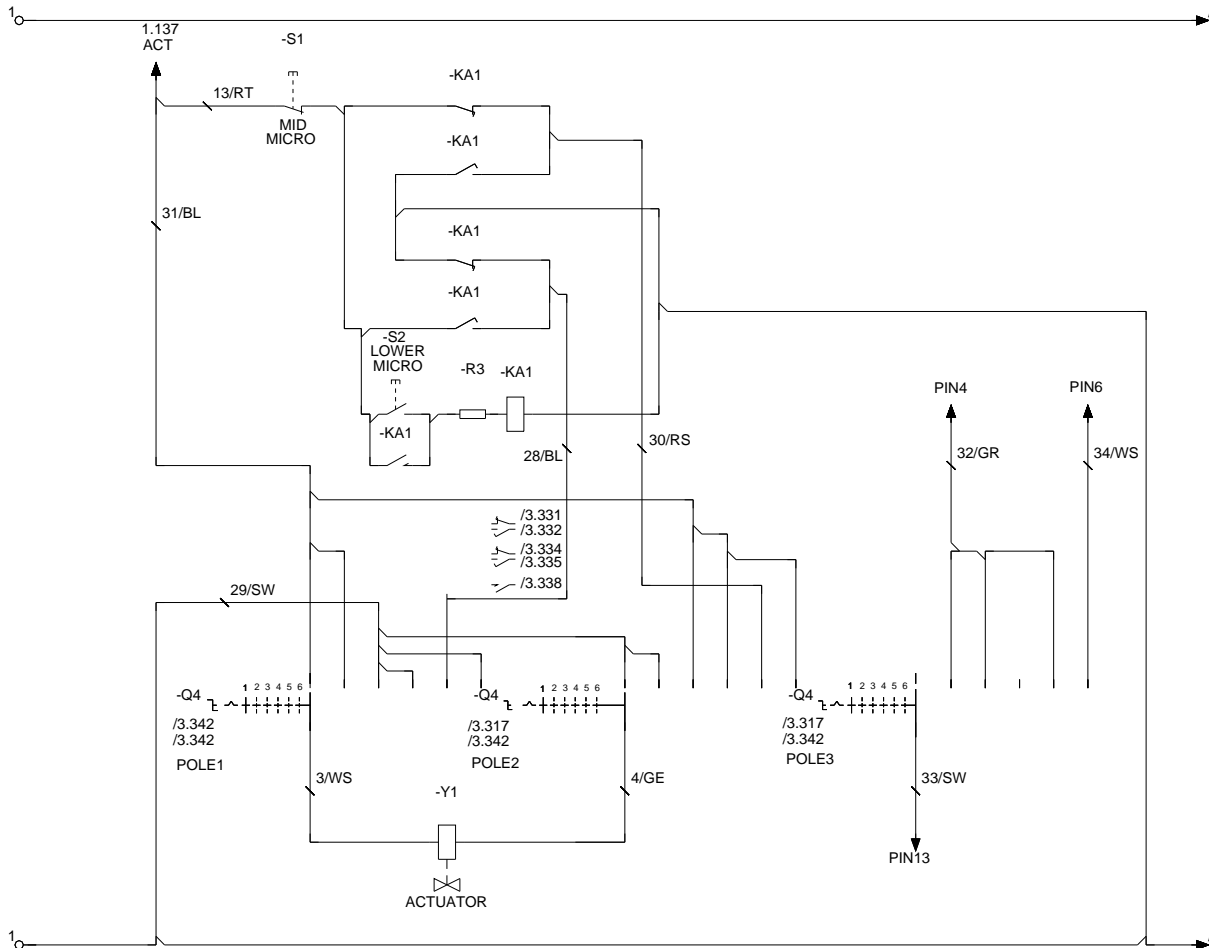

PART NO.	DESCRIPTION	SERIAL NO. FROM	NOTES
86353680	BREAKER, 1.5A CARLING MAGNETIC	(7*)	
86328180	BREAKER, 12A, 250VAC, 32VDC		
86316160	BREAKER, 18A, 250VAC, 32VDC		
86002010	BOOT, 3/8 CIRCUIT BREAKER		
86332510	BOOT, SEAL PUSH BUTTON 11MM		
86313950	SWITCH, SPDT 3 POSN MOM, ARROW		
86007170	SWITCH, KEY 2 POSITION		
86314150	KNOB, SELECTOR		
98408880	KIT, CS20 ROTARY SWITCH		
86302360	DRAIN HOSE		
86199840	FLOAT SCREEN CAGE ASSY (SLIP)		
86331980	BRUSH SET, 8.633-197.0 SCRUB MTR		
86135310	BRUSH SET, 24/36V VAC, WINDSOR		
86007970	STRAINER, 3/8 IN. NPT 60 MESH		
86312920	GASKET, VAC MOTOR		
86326200	GASKET, VACUUM INTAKE		
86327850	GASKET, REC TANK 68"		
86327840	GASKET, VAC MOUNT 27"		
86327830	GASKET,.188X.31X41.0		
86317980	GASKET, DOME		
86326070	BLADE, SQUEEGEE, REAR, DURO 40		
86326060	BLADE, SQUEEGEE, FRONT, DURO 40		
86219690	KNOB, 1.5 OD X 5/16-18		
86348190	NUT, 5/16 PUSH, HAT STYLE, PLTD		CYLINDRICAL ONLY
86010880	WHEEL 1.5OD X .31ID X .75W GRY		CYLINDRICAL ONLY
55152670	DEFLECTOR ROLL SUCTION BAR		CYLINDRICAL ONLY
63212390	STAR GRIP VA Ø50x43		CYLINDRICAL ONLY
62732940	RUBBER LIP SET BR 55/40 RS		CYLINDRICAL ONLY
50319910	END PIECE RIGHT		CYLINDRICAL ONLY
50319900	END PIECE LEFT		CYLINDRICAL ONLY
63484670	TOOTHED BELT HTD-384-3M-20 CXPIII		CYLINDRICAL ONLY
41002260	DRIVESHAFT COMPLETE		CYLINDRICAL ONLY
51106860	SPACER SLEEVE		CYLINDRICAL ONLY
50560100	ROCKER BR-VS		CYLINDRICAL ONLY
56255070	BELT PULLEY 56Z		CYLINDRICAL ONLY
40353810	SHAFT GEAR RIGHT		CYLINDRICAL ONLY

Serial Numbers

REF. NO	MODEL: SERIAL #
1	10061250000400, 10061330000379
2	10061250000432, 10061330000436
3	10061250000436, 10061330000445
4	10061250000481, 10061330000504
5	10061250000617, 10061330000632
6	10061250000938, 10061330001062, 10061370000014, 10061380000001, 10061300000001, 100613400000001
7	10061250001575, 10061300000001, 10061300001671, 10061370000086, 10061380000073, 10061340000004
8	10061250001598, 10061300000009, 10061330001702, 10061340000005, 10061370000096, 10061380000099
9	10061250001494, 10061300000570, 10061330001600, 10061340000005, 10061370000071, 10061380000058
10	10061330001912, 10061420000120
11	10061250002046, 10061300000018, 10061330002230, 10061340000031, 10061370000288, 10061380000307
12	10061250002119, 10061300000025, 10061330002290, 10061340000033, 10061370000314, 10061380000357
13	10061250002130, 10061300000027, 10061330002307, 10061340000038, 10061370000328, 10061380000361,
14	10061250002172, 10061300000029, 10061330002350, 10061340000041, 10061370000354, 10061380000387
15	10061250002391, 10061300000073, 10061330002581, 10061340000507, 10061370000477, 10061380000504
16	10061250002240, 10061300000046, 10061330002460, 10061340000050, 10061370000378, 10061380000447