

BA 625, BA 725, BA 825

PARTS LIST

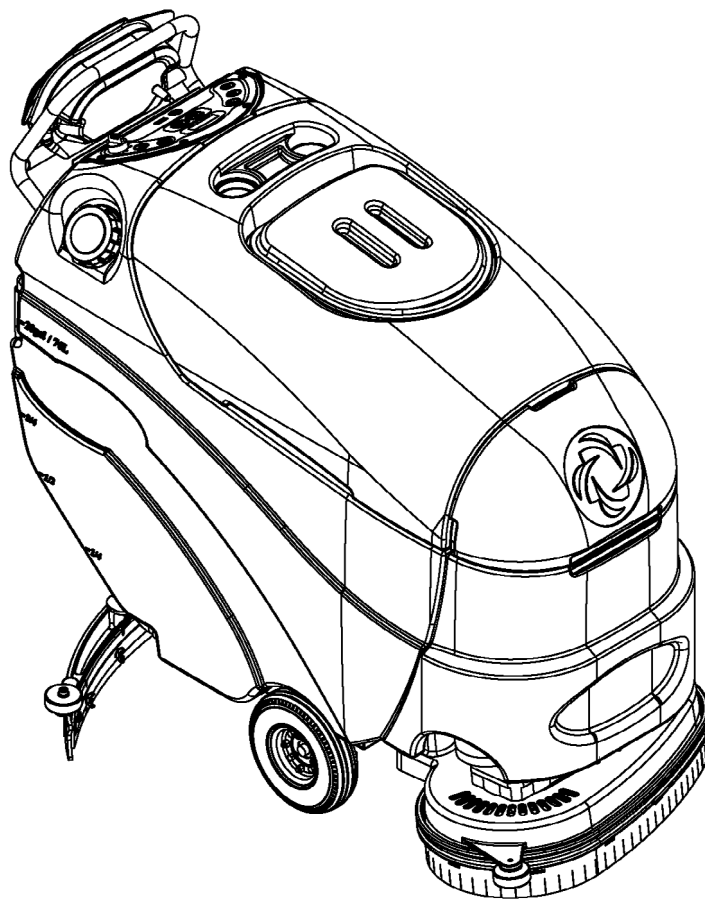

**Nilfisk Models; 56315800(625), 56315801(725),
56315802(725C), 56315803(825)**

9/08 revised 1/11
FORM NO. 56042504

DESCRIPTION	PAGE
Chassis System	2-3
Chassis System (squeegee linkage assy)	4-5
Decal System.....	6-7
Recovery System.....	8-9
Scrub System-Disk (BA 625 / BA 725).....	10-11
Scrub System-Disk (BA 825)	12-13
Scrub System-Cylindrical.....	14-15
Solution System / Electrical-1	16-17
Solution System / Electrical-2	18-19
Paddle Assembly	20-21
Squeegee Assembly	22-23
Wiring Diagram (before September 2009).....	24-25
Wiring Diagram (after August 2009)	26-27
Optional Kits & Accessories.....	28
Brush Selector Guide-Disk	29
Brush Selector Guide-Cylindrical.....	30

WHEN ORDERING PARTS

- * Use the part numbers from the "Ref. No." columns in this parts list.
- * Specify the model and serial number of the machine.
- * Use the space below to record the model and serial number for future reference.

Model _____ Serial No. _____

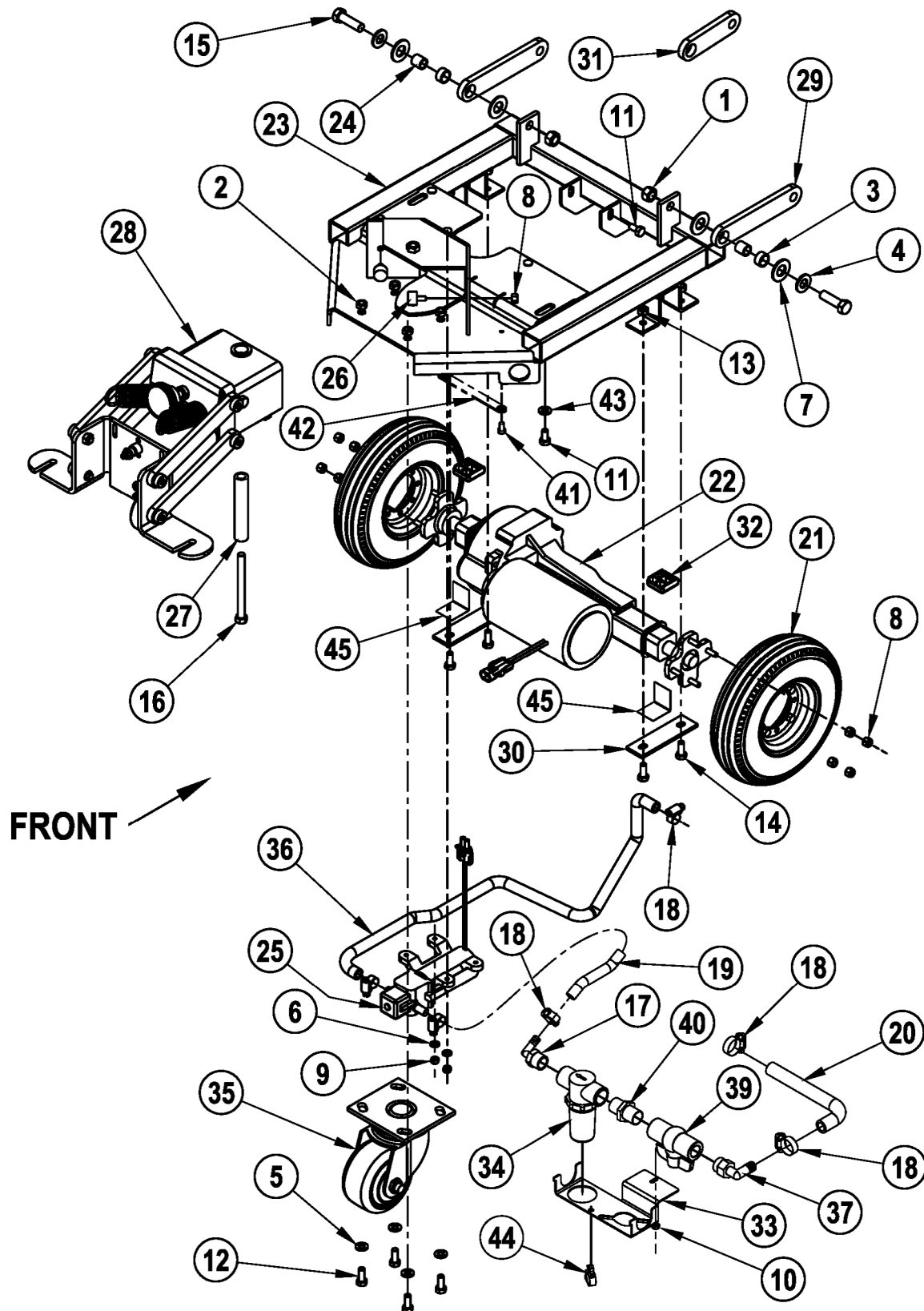

Item	Ref. No.	Qty	Description
1	56003312	2	Nut, Hex Nyl Loc M12-1.75
2	56003389	4	Nut, Hex Nyl Loc M8-1.25
3	56370878	2	Bearing, Sleeve
4	56001879	2	Wsh, Flt SAE 1/2
5	56001939	4	Wsh, Flt SAE 5/16
6	56001954	2	Wsh, Flt SAE #10
7	56002022	4	Wsh, Flt SAE 5/8
8	56002708	10	Nut, Hex Nyl Loc 1/4-20
9	56002768	2	Nut, Hex Nyl Loc 10-24
10	56002832	1	Nut, Hex Nyl Loc-Thin 10-24
11	56003012	3	Scr, Hex Hd SS 5/16-18x.75
12	56003179	4	Scr, Hex Thd To Hd M8-1.25x20mm
13	56003405	4	Nut, Hex Nyl Loc SS M8x1.25
14	56003435	4	Scr, Hex Hd SS 8-1.25x20mm
15	56003637	2	Scr, Hex M12-1.75x40mm
16	56009241	1	Scr, Hex Hd 3/8-16x4.25
17	56900033	1	Barb, 90 Elbow 3/8 X 1/2 NPT
18	56219932	6	Clamp, Hose SAE #6
19	56244991	1	Hose-pvc .38 X 15.00
20	56262180	1	Hose, Spiral .500
21	56315115	2	Wheel, Drive TSBUS2006-941
22	56315062	1	Transaxle, 24V (M1) TSBUS2008-1014
*	56315377	1	Motor
*	56315378	4	Carbon Brush
*	56315379	2	Neoprene Mounting Sleeve
*	56380497	A/R	Transaxle Kit TSBUS2008-1014
*	56380503	A/R	Transaxle Hub Kit TSBUS2008-1018
*	56380161	1	Kit-Coupling
23	56315076	1	Weldment, Chassis TSBUS2005-895
24	56315080	2	Bushing
25	56315108	1	Pump, 24VDC (M8)
26	56315111	2	Cylindrical Mount
27	56315154	1	Bushing, Spacer
28	56315165	1	Assembly, Squeegee Linkage
29	56315179	2	Linkage Arm
30	56315234	2	Plate NOTE 1
	56380499	2	Plate, Transaxle NOTE 2
31	56315239	1	Linkage Arm only used before May 2007
32	56315258	2	Shim
33#	56381476	1	Bracket, Filter Mount NOTE 4
34	56315296	1	Solution Filter
35	56365555	1	Caster Swivel 4.0 x 2.0
36	56391802	1	Hose, Spiral .375
37	56409152	1	Barb, 90 Elbow 1/2 X 1/2npt
39#	56381475	1	Ball Valve NOTE 4
40#	56381474	1	Nipple NOTE 4
41	56009030	1	Scr, Pan Phil Thd Form 10-24 x .38
42	56467544	1	Chain
43	56002220	2	Wsh, Flt STD 5/16
44	56900756	1	Clip, Conduit
45	56380496	2	Shim, Transaxle Angle NOTE 3

* = Not Shown

= Revised or new since last update

NOTE 1: Used on all models before SN 2062812.

NOTE 2: Used on all models after SN 2062812.

NOTE 3: Only used on machines between the following serial numbers;
All models– between SN 2062812 & 2063621.

#NOTE 4: 56315260(Bracket), 56315607(Ball Valve) & 56412182(Nipple) are no longer used in production and no longer available. If you need to replace any of these items please order Ball Valve Bracket Kit 56381521.

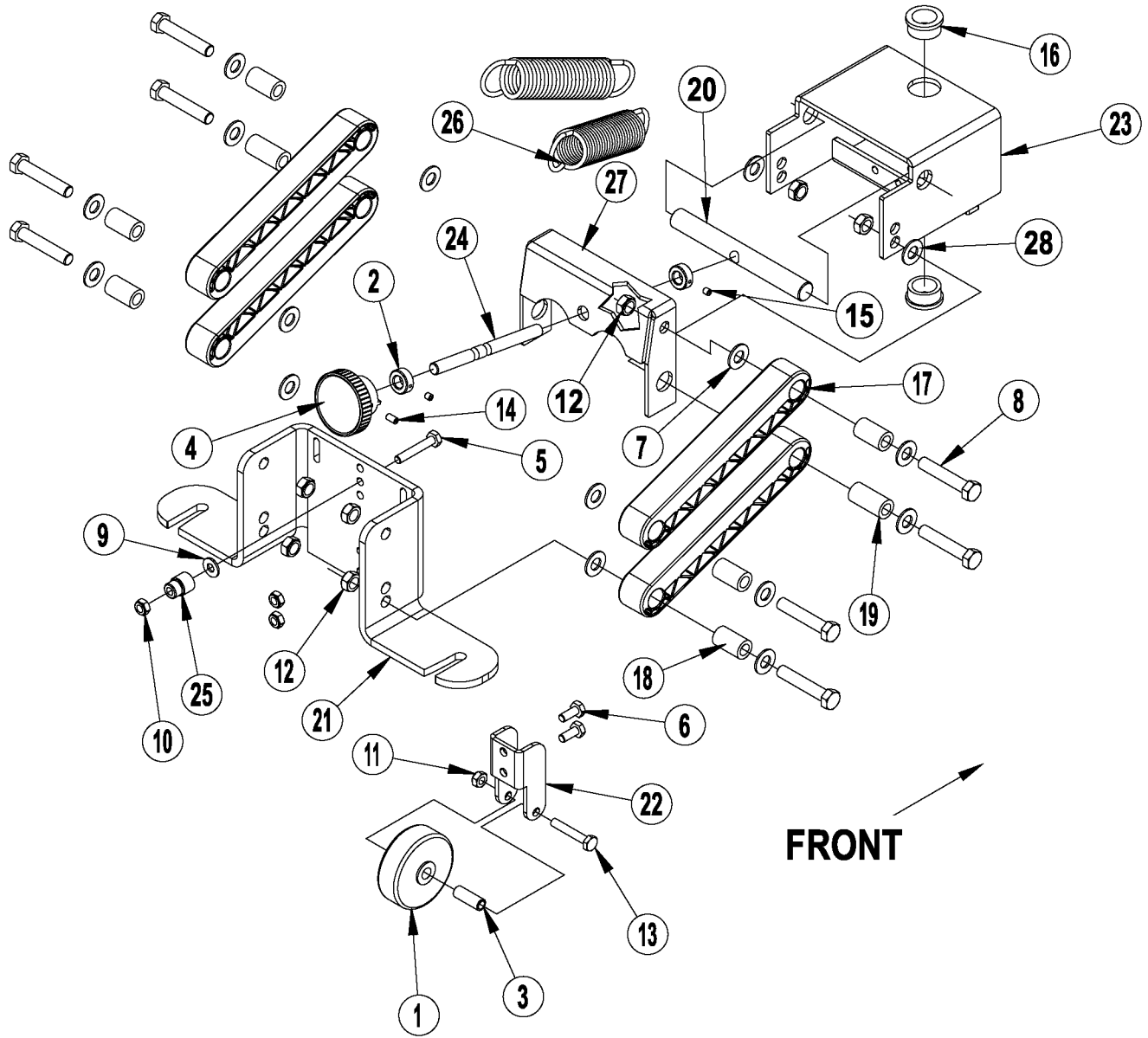

08-9	CHASSIS SYSTEM (squeegee linkage assy)		
10-4		BA 625, BA 725, BA 825	5

Item	Ref. No.	Qty	Description
	56315165	1	Squeegee Linkage Assembly
1	56324350	1	Wheel
2	56331076	2	Collar
3	56315580	1	Bushing
4	56475480	1	Knob
5	56001833	1	Scr, Hex 1/4-20 X 1.50
6	56001836	2	Scr, Hex 1/4-20 X .62
7	56002063	14	Wsh, Flt SAE 3/8
8	56002091	8	Scr, Hex 3/8-16 X 2.00
9	56002098	1	Wsh, Flt SAE 1/4
10	56002840	3	Nut, Hex Nyl Loc-Thin 1/4-20
11	56002850	1	Nut, Hex Nyl Loc-Thin SS 1/4-20
12	56002852	8	Nut, Hex Nyl Loc-Thin SS 3/8-16
13	56002880	1	Scr, Hex Loc SS 1/4-20 x 1.75
14	56003123	1	Scr, Soc Set 10-2 4x .38
15	56009084	2	Scr, Soc Set Loc 10-24 X .19
16	56250414	2	Bearing, Flange
17	56315941	4	Linkage Arm, Molded
18	56315067	6	Spacer, Phenolic
19	56315068	2	Spacer, Phenolic
20	56315082	1	Pin
21	56315151	1	Bracket, Squeegee Mount
22	56315153	1	Bracket, Wheel
23	56315196	1	Weldment, Squeegee
24	56315240	1	Rod, Adjustment
25	56315245	1	Bushing, Squeegee Cable
26	56315295	2	Spring, Extension
27	56315713	1	Bracket, Squeegee Level
28	56002940	2	Wsh, Flt SAE SS 5/8

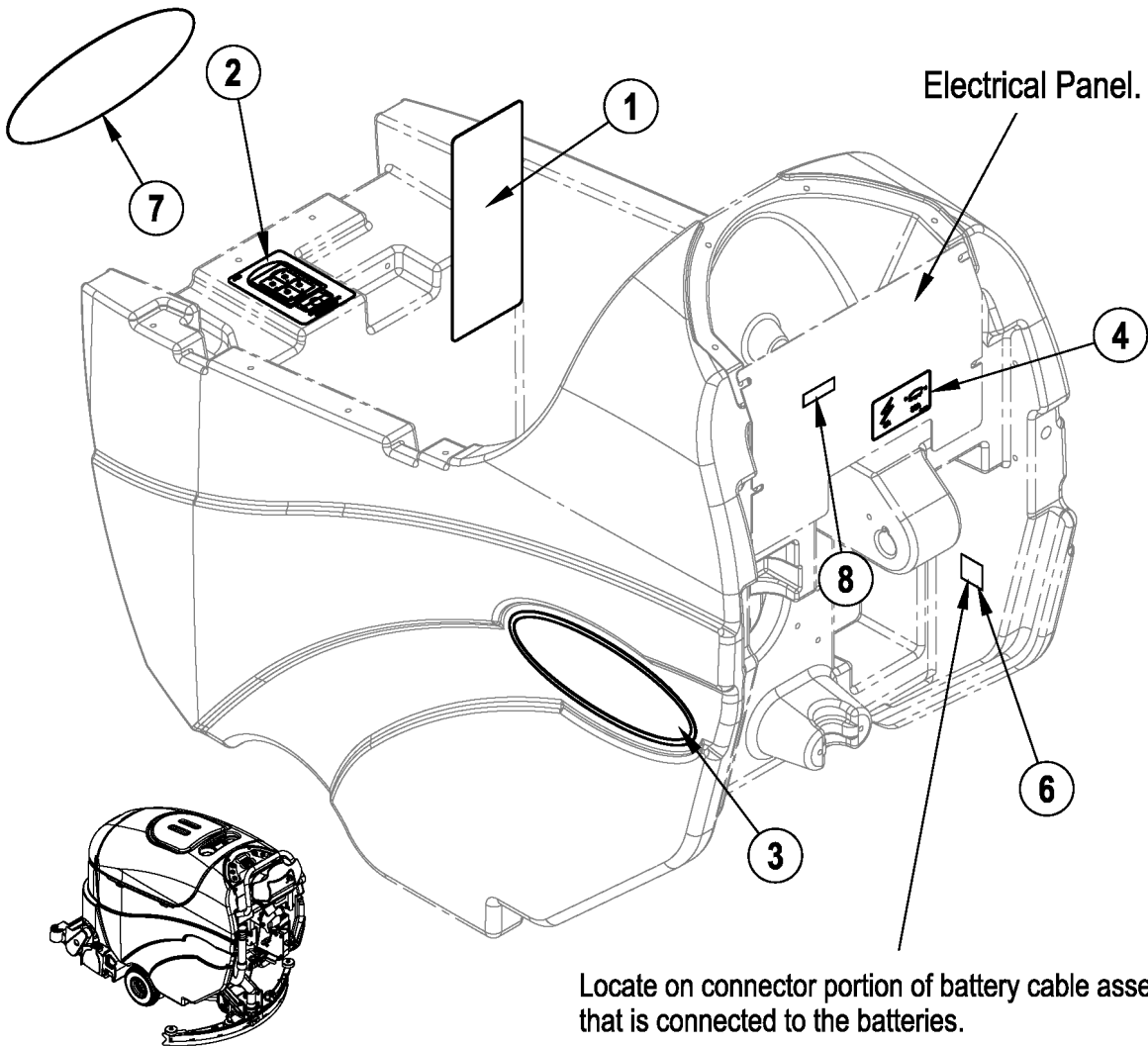

08-9

DECAL SYSTEM

10-9

BA 625, BA 725, BA 825

7

Item	Ref. No.	Qty	Description
1	56014601	1	Decal, Caution
2	56380515	1	Decal, Battery Wiring
3	56315830	2	Decal, BA625
	56315831	2	Decal, BA725
	56315832	2	Decal, BA825
4	56016690	1	Decal, Circuit Breaker
6	56054192	1	Decal, Charger
7	56317130	1	Decal, Nilfisk
8	56014450	1	Decal, Patent Number

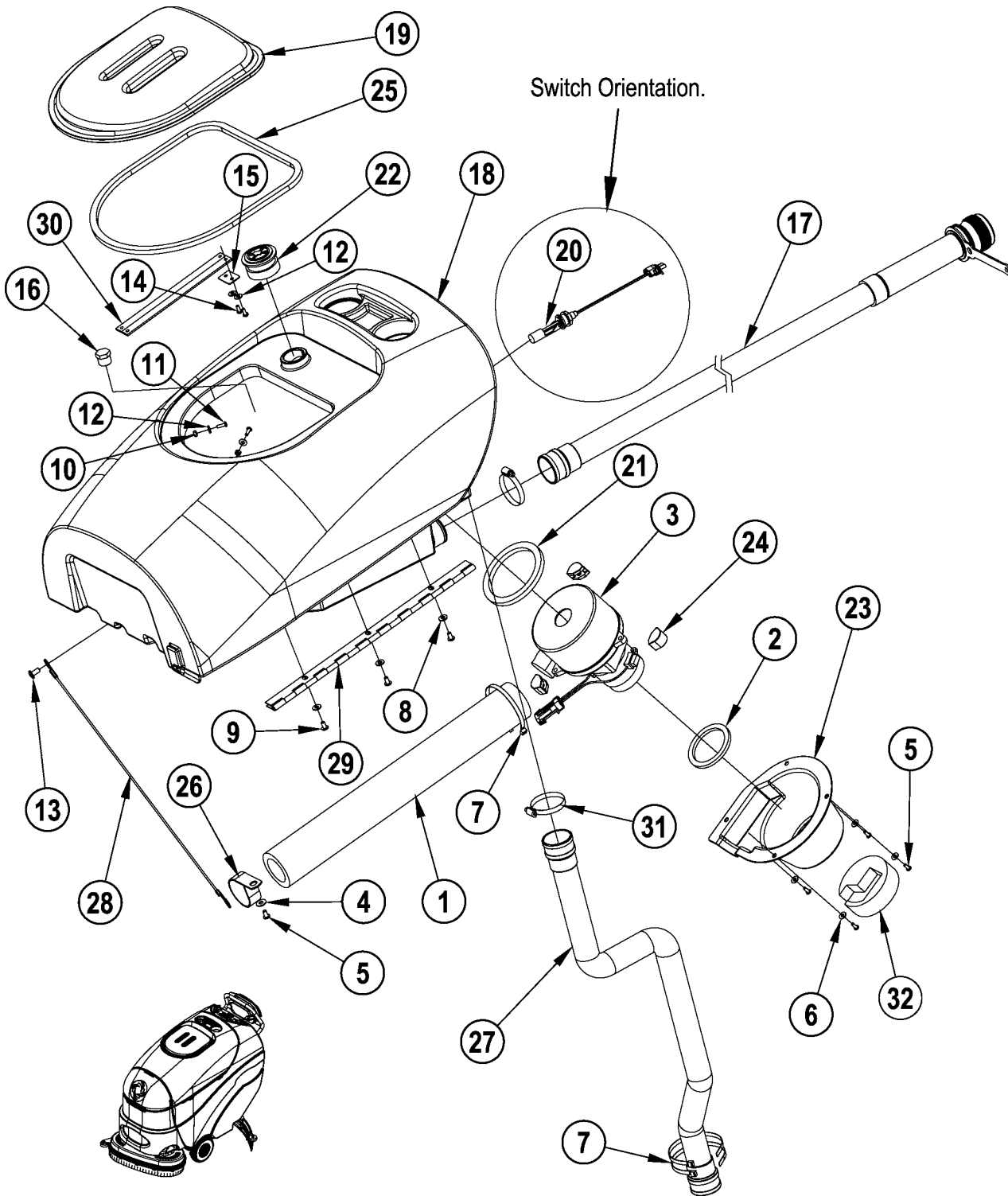

08-9	RECOVERY SYSTEM			
09-3	BA 625, BA 725, BA 825			9

Item	Ref. No.	Qty	Description
1	56315847	1	Foam Tube Assembly
2	56412154	1	Gasket, Vacuum Duct
3	56412300	1	Motor, Vac 24vdc W/Filter (M4)
*	56397098	1	Carbon Brush set of 2 (for 56412300) NOTE 3
*	56380529	1	Carbon Brush set of 2 (for 56412300) NOTE 3
4	56001906	1	Wsh, Flt STD 1/4
5	56001993	5	Scr, Pan Phil 10-24x.50
6	56002053	4	Wsh, Flt STD #10
7	56477613	3	Tie, Cable
8	56002098	3	Wsh, Flt SAE 1/4
9	56002145	3	Scr, Pan Phil 1/4-20x.50
10	56002849	2	Nut, Hex Nyl Loc-Thin SS 10-24
11	56002896	2	Scr, Pan Phil SS 10-24x.62
12	56002919	4	Wsh, Flt STD SS #10
13	56003003	1	Scr, Pan Phil 5/16-18x.62
14	56009005	2	Scr, Pan Phil SS Type B 10-16 x .75
15	56315346	1	Plate
16	56305464	1	Plug,3/4 Hex Pipe NOTE 1
17	56601400	1	Drain Hose NOTE 2
**	56601410	1	Drain Hose Extension (for use with 56601400)
*	56601411	1	Drain Hose Cap Kit
*	56601412	1	Drain Hose Kit NOTE 2
18	56315779	1	Tank, Recovery
19	56315176	1	Cover, Recovery Tank
20	56315096	1	Switch, Electromagnetic (S4)
21	56315098	1	Gasket
22	56315099	1	Screen, Fan Inlet
23	56315102	1	Shroud, Vac Motor
24	56315141	3	Mount, Vibration
25	56315220	1	Gasket, Recovery Lid
26	56315257	1	Clamp, P
27	56315268	1	Vac Hose Assy.
28	56315272	1	Cable Assy
29	56315293	1	Hinge
30	56315303	2	Retaining, Strap
31	56440213	2	Clamp, Hose SAE #32
32	56315840	1	Duct, Vac Inlet

* = Not Shown

** = Optional

NOTE 1: Not used after March 2008.

NOTE 2: Drain Hose 56397142 has been replaced by Drain Hose 56601400 in production. When replacing 56397142 you need to order Drain Hose Kit 56601412.

NOTE 3: If your vacuum motor has a serial tag from Lamb Electric (Ametek) order Carbon Brush Set 56397098.
If your vacuum motor has a serial tag from Nilfisk-Advance order Carbon Brush Set 56380529.

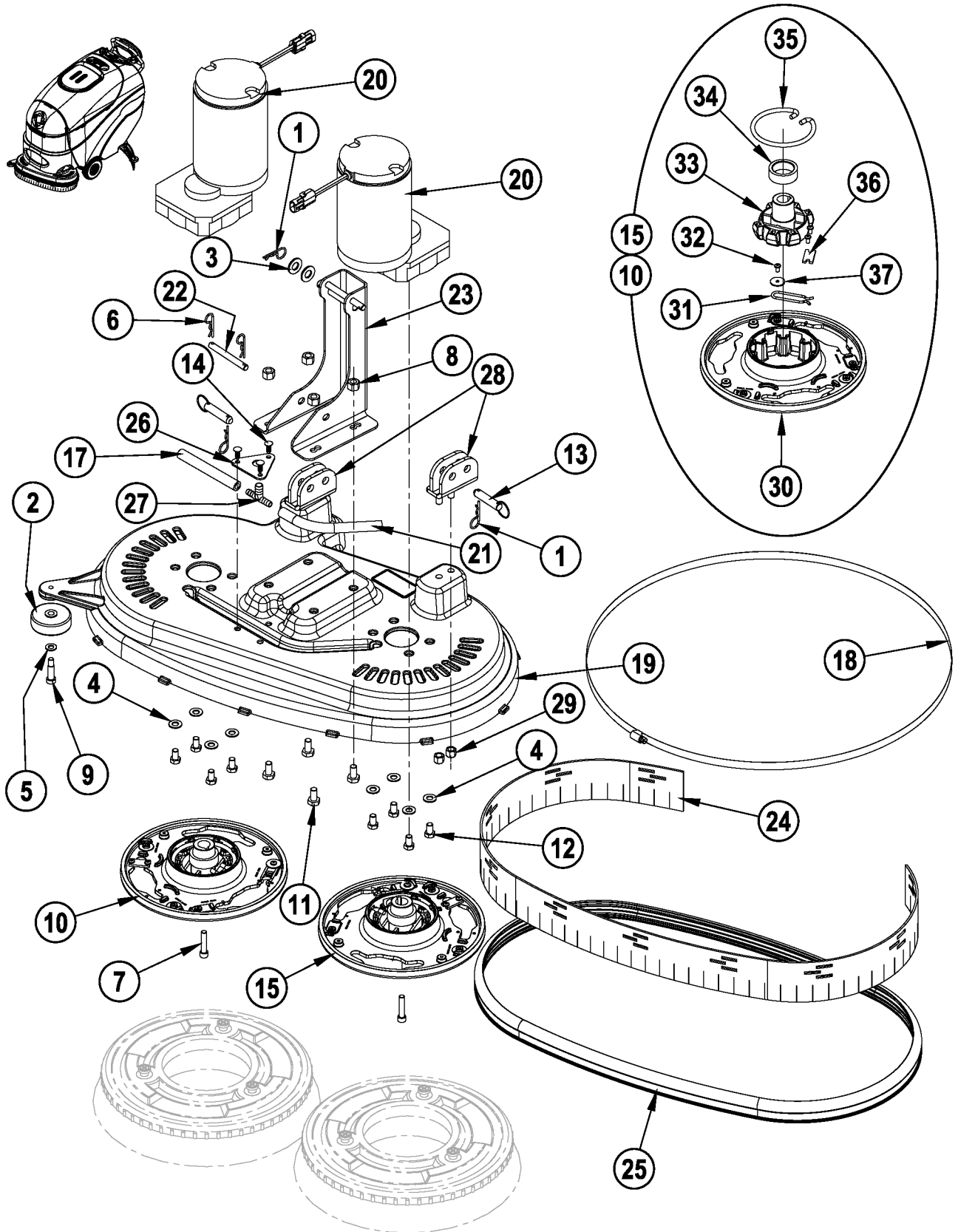

Item	Ref. No.	Qty	Description	Item	Ref. No.	Qty	Description
1	56002959	3	Pin, Cotter Hair NOTE 3	23	56315718	1	Weld't, Deck Actuator (BA 625) NOTE 2, NOTE 3
2	56324350	1	Wheel	56315719	1	Weld't, Deck Actuator (BA 725) NOTE 2	
3	56001879	2	Wsh, Flt SAE 1/2 NOTE 3				NOTE 3
4	56002910	8	Wsh, Flt SAE SS 3/8	24	56315274	1	Skirt, Rubber (BA 625 / BA 725)
5	56002938	1	Wsh, Flt SAE SS 5/16	25	56315754	1	Bumper, Extruded (BA 725) NOTE 4
6	56003120	2	Pin, Cotter Hair .0915 X .375	56315752	1	Bumper, Extruded (BA 625) NOTE 4	
7	56002201	2	Scr, Soc Hd 5/16-18 x 1.50 NOTE 5	26	56315339	1	Bracket
8	56003438	4	Nut, Hex Nyl Loc SS M10x1.5	27	56397300	1	Tee, Barb NOTE 1
9	56003472	1	Scr, Soc Shd .38 X 1.00 X 5/16-18	28	56315373	2	Weld't, Deck Mount Brkt NOTE 2
10	56109651	1	Brush Plate Assy (30-37) NOTE 5 / TSBUS2009-1039	29	56002769	4	Nut, Hex Nyl Loc 3/8-16 NOTE 2
11	56003533	4	Scr, Hex Hd SS M10-1.5x20mm	30	56601118	1	Brush Plate NOTE 5
12	56003674	8	Scr Hex Loc SS 3/8-24 X .62	31	56109653	1	Spring Retainer NOTE 5
13	56003679	2	Pin, Ring .50 X 1.63	32	56009247	3	Scr, Pan Phil Plastite 10-14 X .38 NOTE 5
14	56003693	3	Rivet, Nylon Tree Push-In (.218)	33	56601520	1	Gimbal, Motor NOTE 5
15	56109652	1	Brush Plate Assy (30-37) NOTE 5 / TSBUS2009-1039	34	61658a	1	Collar, Brush Driver NOTE 5
17	56257534	1	Hose, PVC .375	35	56601056	1	Spring, Brush Holder NOTE 5
18	56315759	1	Band Clamp (BA 725)	36	56366455	1	Plate, Stop NOTE 5
	56315742	1	Band Clamp (BA 625)	37	56009002	1	Wsh, Flt .266 X .906 X .060 NOTE 5
19	56315588	1	Scrub Deck, Disc, Cast, BA 725 NOTE 2	*	56315838	2	Harness, Filter
	56315586	1	Scrub Deck, Disc, Cast, BA 625 NOTE 2	*	56413883	2	Ferrite Bead
20	56315056	2	Asm, Motor And Gear Unit, .42hp (M2 / M3)				
*	56315376	4	Carbon Brush				
*	56397138	4	Brush Spring				
21	56315060	1	Hose, PVC .375				
22	56315161	1	Pin				

* = Not Shown

NOTE 1: The previous solution hose design which consisted of a Reducer (56418669), Hose Clamps (56219932) and a smaller 3/8" diameter Hose (56456830) to the scrub deck has been replaced in production with a single 1/2" diameter hose (56264318). If ordering Tee 56397300 for a machine with this previous design solution hose you will also need to order Solution Hose 56264318. See **NOTE 1** on **SOLUTION SYSTEM / ELECTRICAL-1**.

NOTE 2: The Deck Casting (item #19) has been redesigned. The old style castings (56315053 - 28", 56315054 - 26" & 56315055 - 24") are no longer available. If you have a machine built prior to this change (**old style deck assembly DOES NOT include item 38**) and need to replace one of these deck castings you need to order one of the kits listed below. These kits include items (8, 11, 14, 19, 23, 38, 39).

Old Deck	Order Kit
56315053 (28")	56315727
56315054 (26")	56315726
56315055 (24")	56315725

NOTE 3: Actuator Weldment Item #23 has been redesigned (in April of 2007) to accommodate a new upper deck linkage arm (see **Solution System / Electrical-1**). The redesigned weldment is backwards compatible to the previous design. The new design does not use item #3 and the quantity of item #1 is reduced to 2.

NOTE 4: Extruded Bumpers PNs 56315318, 56315277 & 56315276 are obsolete. If you need to replace one of these bumpers please order one of the kits listed below.

Old Bumper	Order Kit
56315318 (28")	56315764
56315277 (26")	56315763
56315276 (24")	56315762

NOTE 5: Drive Lugs 56396080 and 56396081 are both obsolete and replaced by 56109625 and 56109626 respectively. The old individual parts are still available for replacement and listed below.

Item	Ref. No.	Qty	Description
38	56396080	1	Lug, Counterclockwise (40-51) NOTE 5
39	56396081	1	Lug, Clockwise (40-51) NOTE 5
40	56003335	2	Scr Hex Loc SS 5/16-18 X .88
41	56003477	6	Scr, Hex Loc SS M8-1x25mm
42	56009107	2	Wsh, Flt SS .378 X 1.000 X .120
43	56314108	2	Hub, Drive
44	56002938	6	Wsh, Flt SAE SS 5/16
45	56003405	3	Nut, Hex Nyl Loc SS M8-1.25
46	56003639	3	Scr, Hex Hd SS M8-1.25 x 25mm
47	56009030	1	Scr, Pan Phil Thd Form 10-24 x .38
48	56009096	1	Wsh, Flt .193 x .875 x .060
49	56407053	2	Thermoid Disk
50	56314030	1	Brush Holder
51	56397081	1	Spring Retainer

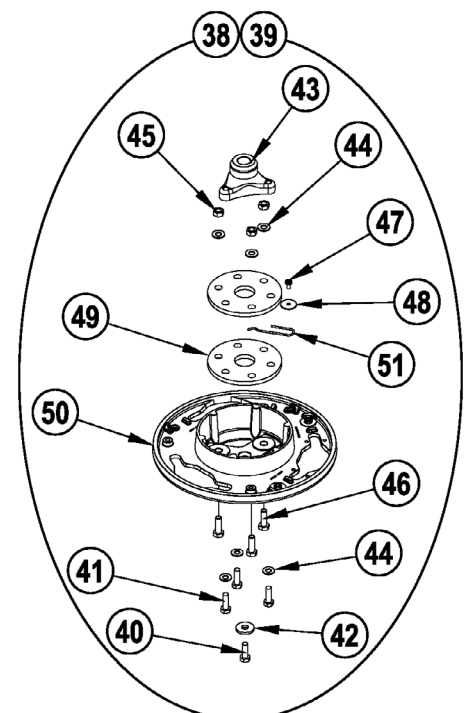

FORM NO. 56042504

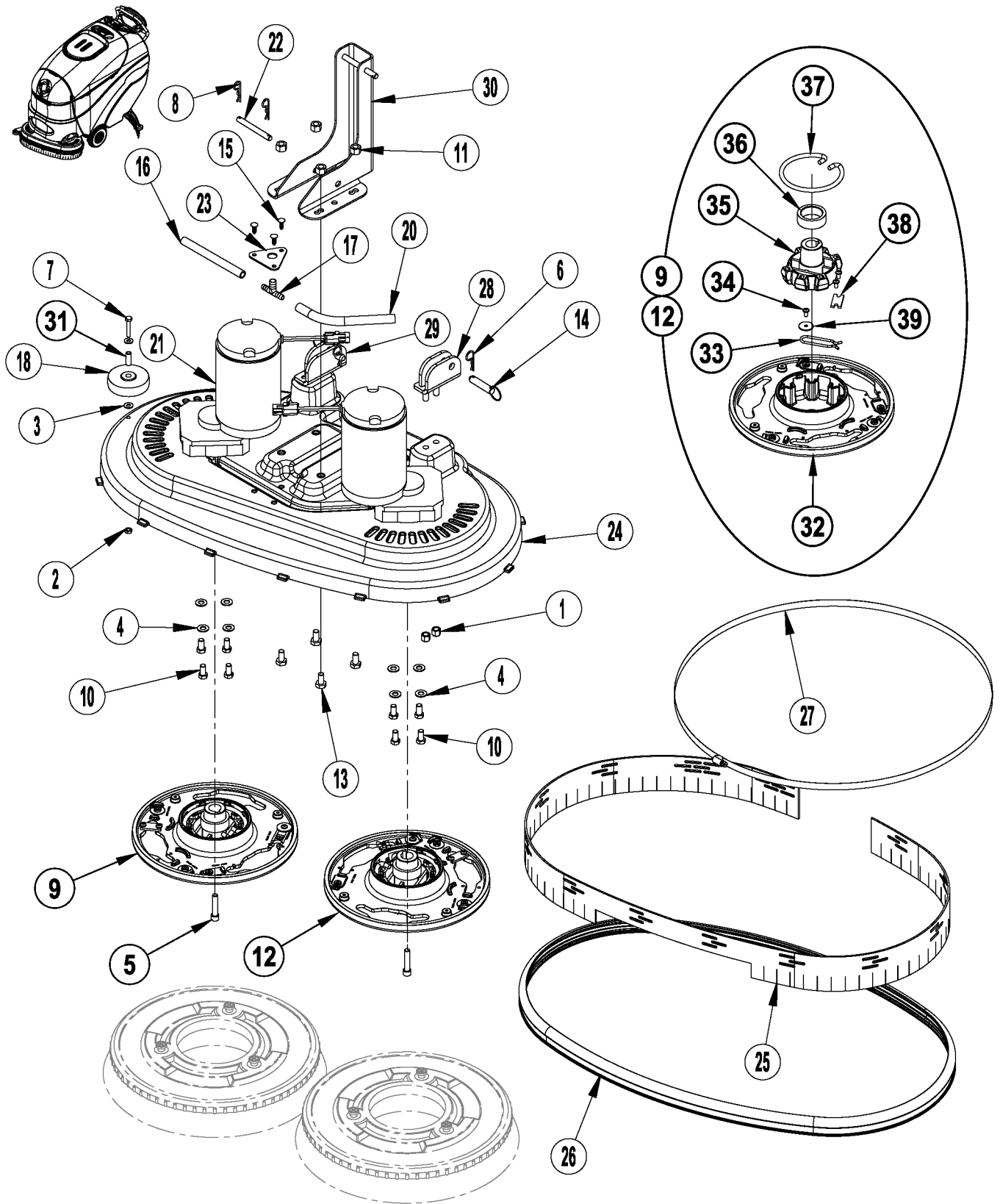

08-9	SCRUB SYSTEM - DISK (BA 825)		
09-12	BA 625, BA 725, BA 825		13

Item	Ref. No.	Qty	Description
1	56002769	4	Nut, Hex Nyl Loc 3/8-16
2	56002850	1	Nut, Hex Nyl Loc-Thin SS 1/4-20
3	56002859	2	Wsh, Flt SAE SS 1/4
4	56002910	8	Wsh, Flt SAE SS 3/8
5	56002201	2	Scr, Soc Hd 5/16-18 x 1.50 NOTE 1
6	56002959	2	Pin, Cotter Hair
7	56002880	1	Scr, Hex Loc SS 1/4-20 X 1.75
8	56003120	2	Pin, Cotter Hair .0915 X .375
9	56109651	1	Brush Plate Assy (32-39) NOTE 1 / TSBUS2009-1039
10	56003338	8	Scr, Hex Loc SS 3/8-16 X .75
11	56003438	4	Nut, Hex Nyl Loc SS M10-1.5
12	56109652	1	Brush Plate Assy (32-39) NOTE 1 / TSBUS2009-1039
13	56003533	4	Scr, Hex SS M10-1.5 X 20mm
14	56003679	2	Pin, Ring .50 X 1.63
15	56003693	3	Rivet, Nylon Tree Push-In (.218)
16	56396195	1	Hose, PVC .38id X 6.00
17	56397300	1	Tee, Barb
18	56049261	1	Wheel
20	56397301	1	Hose, PVC .375
21	56315056	2	Asm, Motor And Gear Unit, .42HP (M2 / M3)
*	56315376	4	Carbon Brush
*	56397138	4	Brush Spring
22	56315161	1	Pin
23	56315339	1	Bracket
24	56315859	1	Scrub Deck, Disc, Cast, 32"
25	56315626	1	Skirt, Rubber 32"
26	56315755	1	Extruded Bumper, 32" Deck
27	56315761	1	Band Clamp, Adjustable
28	56315821	1	Deck Mount Brkt Weldt, Lhs
29	56315823	1	Deck Mount Brkt Weldt, Rhs
30	56315826	1	Bracket Weld't
31	56315580	1	Bushing, Stainless
32	56601118	1	Brush Plate NOTE 1
33	56109653	1	Spring Retainer NOTE 1
34	56009247	3	Scr, Pan Phil Plastite 10-14 X .38 NOTE 1
35	56601520	1	Gimbal, Motor NOTE 1
36	61658a	1	Collar, Brush Driver NOTE 1
37	56601056	1	Spring, Brush Holder NOTE 1
38	56366455	1	Plate, Stop NOTE 1
39	56009002	1	Wsh, Flt .266 X .906 X .060 NOTE 1
*	56315838	2	Harness, Filter
*	56413883	2	Ferrite Bead

* = Not Shown

NOTE 1: See NOTE 5 on **SCRUB SYSTEM - DISK (BA 625, BA 725)**

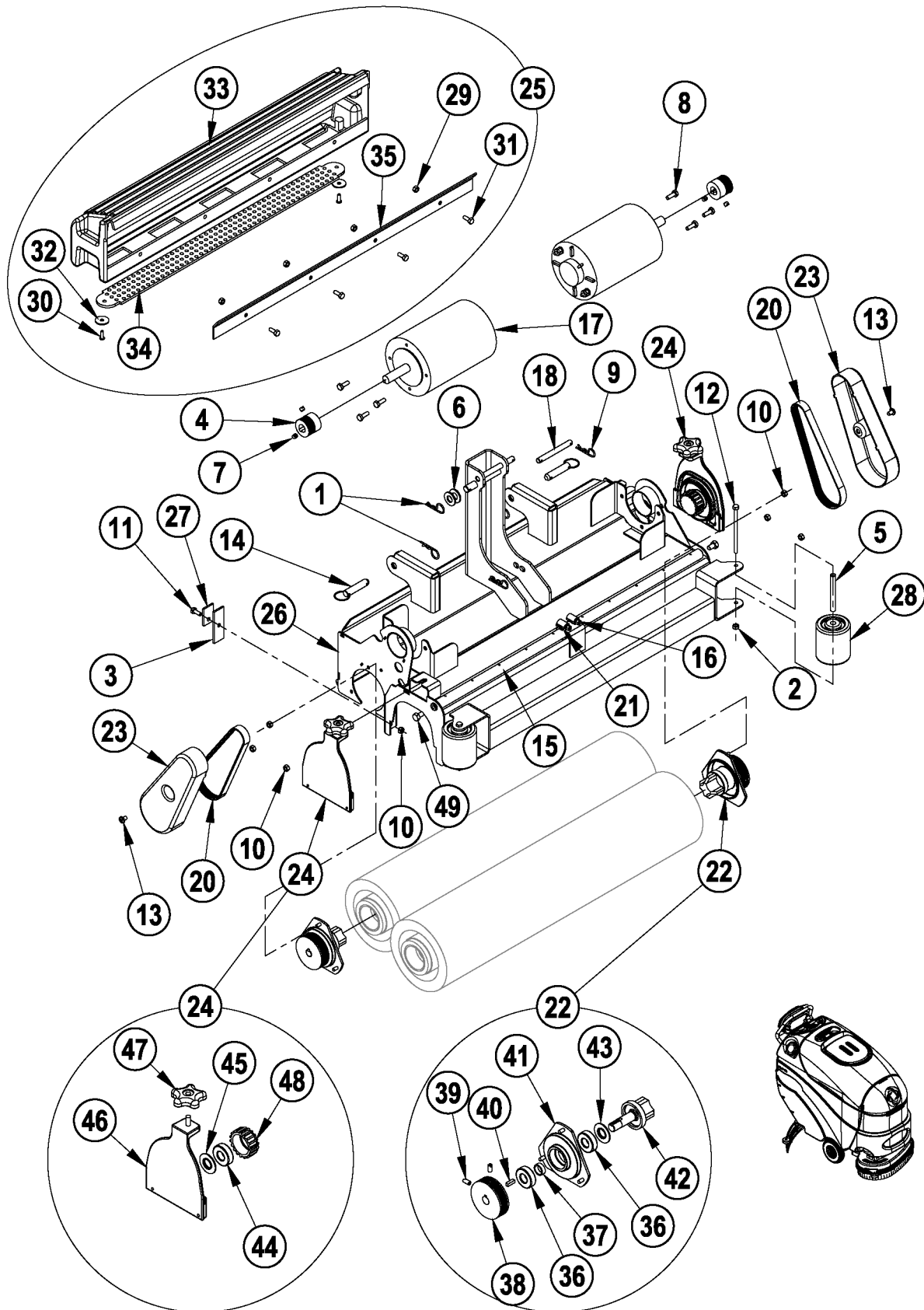

08-9

SCRUB SYSTEM - CYLINDRICAL

10-9

BA 625, BA 725, BA 825**15**

Item	Ref. No.	Qty	Description	Item	Ref. No.	Qty	Description
1	56002959	3	Pin, Cotter Hair NOTE 2	27	56410214	2	Strap
2	56003403	2	Nut, Hex Nyl Loc M6-1.00	28	56412459	2	Wheel
3	56407391	2	Blade	29	56003426	4	Nut, Hex Nyl Loc SS M6-1.00
4	56407433	2	Sheave, Poly-V	30	56002896	2	Scr, Pan Phil SS 10-24 x .62
5	56412176	2	Bushing	31	56003431	4	Scr, Hex Hd SS M6-1.00 x 16mm
6	56001879	6	Wsh, Flt SAE 1/2 NOTE 2	32	56009060	2	Wsh, Flt SS .260 x 1.00 x .074
7	56002086	4	Scr, Soc Set Loc 5/16-18x.25	33	56315460	1	Hopper (BA 725)
8	56002948	6	Scr, Hex Hd Loc 1/4-20x.75	34	56315464	1	Hopper Screen (BA 725)
9	56003120	2	Pin, Cotter Hair .0915 X .375	35	56315467	1	Hopper Bracket (BA 725)
10	56003426	8	Nut, Hex Nyl Loc SS M6x1.0	36	56106070	2	Bearing, Ball
11	56003431	2	Scr, Hex Hd SS M6-1.0x16mm	37	56407389	1	Spacer
12	56003492	2	Scr, Hex M6-1.0x95mm	38	56407442	1	Sheave, Poly-V
13	56003603	2	Scr, Pan Phil Thd Form 1/4-20x.38	39	56002119	2	Scr, Soc Set Loc 1/4-20 x .50
14	56003679	2	Pin, Ring .50 X 1.63	40	56003237	1	Key, Sq. .19 x .62
15	56315355	2	Manifold, PVC (BA 725)	41	56315405	1	Bearing Plate
16	56112771	2	Clamp, Hose SAE #10	42	56109527	1	Spindle
17	56315061	2	Motor, 24 Vdc, .5 Hp, 1800 RPM (M2 / M3) TSBUS2010-1058	43	56407558	1	Washer, Bearing
*	56412287	1	Brush / Spring Kit NOTE 3	44	56106070	1	Bearing, Ball
*	56380003	1	Brush / Spring Kit NOTE 3	45	56407558	1	Washer, Bearing
18	56315161	1	Pin	46	56315447	1	Idler Bearing Plate
19	56315320	2	Harness, Brush	47	56396254	1	Knob
20	56315321	2	Belt, Auto Tension	48	56407551	1	Hub
21	56262549	1	Tee, Barb NOTE 1				
22	56315408	2	Drive End Assy (#36-43)	*	56315838	2	Harness, Filter
23	56315445	2	Cover, Belt				
24	56315448	2	Idler End Assy (#44-48)				
25	56315459	1	Hopper Assembly (BA 725 / #29-35)				
26	56315470	1	Housing, Weld't (BA 725)				

* = Not Shown

NOTE 1: The previous solution hose design which consisted of a Reducer (56418669), Hose Clamps (56219932) and a smaller 3/8" diameter Hose (56456830) to the scrub deck has been replaced in production with a single 1/2" diameter hose (56264318). If ordering Tee 56262549 for a machine with this previous design solution hose you will also need to order Solution Hose 56264318. See **NOTE 1** on **SOLUTION SYSTEM / ELECTRICAL-1**.

NOTE 2: Housing Weldment Item #26 has been redesigned (in April of 2007) to accommodate a new upper deck linkage arm (see **Solution System / Electrical-1**). The redesigned weldment is backwards compatible to the previous design. On machines with the new design the quantity of item #1 is reduced to 2 and the quantity of item #6 is reduced to 4.

NOTE 3: If your cylindrical scrub motor has a serial tag from Scott Motors Co. (4BB1344) order Carbon Brush Set 56412287.
If your cylindrical scrub motor has a serial tag from Nilfisk-Advance (ZD22000) order Carbon Brush Set 56380003.

FORM NO. 56042504

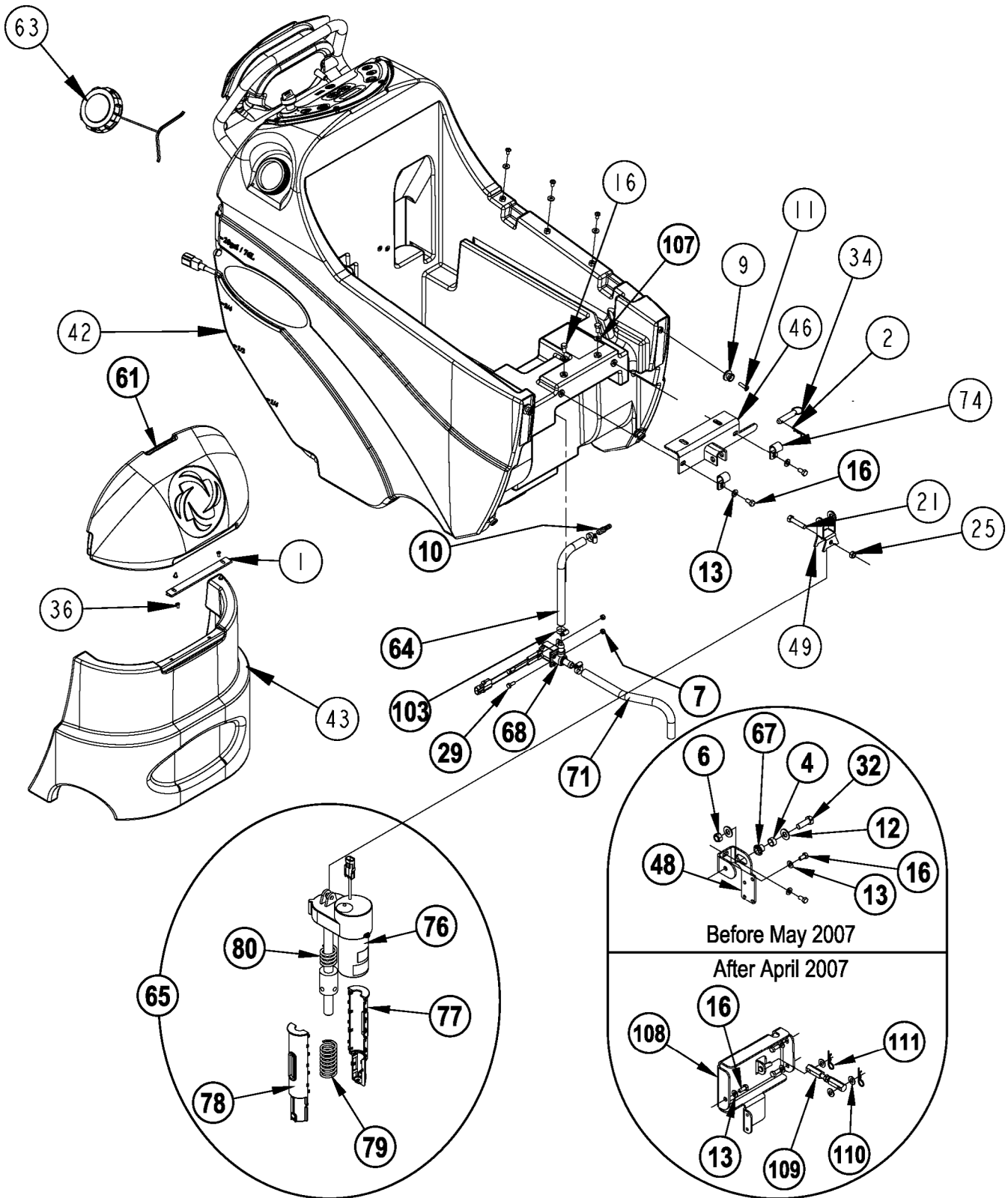

Item	Ref. No.	Qty	Description
1	56315285	1	Hinge
2	56002959	1	Pin, Cotter Hair
4	56370878	1	Bearing, Sleeve only used before May 2007
6	56003312	1	Nut, Hex Nyl Loc M12-1.75 only used before May 2007
7	56003403	2	Nut, Hex Nyl Loc M6-1.00
9	56365777	4	Lug, Brush Driver
10	56418669	1	Reducer, Barb
11	56001832	4	Scr, Flt Phil 1/4-20x1.00
12	56001879	2	Wsh, Flt SAE 1/2
13	56001939	4	Wsh, Flt SAE 5/16 QTY of 5 after April 2007
16	56002667	6	Scr, Hex Hd 5/16-18x.75 QTY of 7 after April 2007
21	56002684	1	Scr, Hex Hd 3/8-16x1.75
25	56002841	1	Nut, Hex Nyl Loc-Thin 3/8-16
29	56003174	2	Scr Hex Thd To Hd M6-1.0x16mm
32	56003637	1	Scr, Hex M12-1.75x40mm only used before May 2007
34	56003679	1	Pin, Ring .50 X 1.63
36	56009139	4	Scr, Pan Phil Loc 10-24x.38
42	56315089	1	Tank, Solution
**	56109561	1	Solution Tank Kit NOTE 3 / TSBUS2008-1017
43	56315104	1	Nose Cone, 24-26 Commercial
46	56315130	1	Weldment, Actuator Mount
48	56315186	1	Bracket, Linkage Pivot only used before May 2007
49	56315191	1	Yoke, Actuator
61	56315284	1	Cover, Chemical Bottle
63	56601599	1	Cap, Raw W/Tether NOTE 2
64	56387302	1	Spiral, Hose X .500
65	56109595	1	Lift Actuator Assembly (76-80) NOTE 4 / TSBUS2009-1040
67	56315380	1	Bushing only used before May 2007
68	56397203	1	Solenoid Valve Assy. (L1)
71	56264318	1	Hose, Spiral .500 NOTE 1
74	56469380	2	Clamp, P
76	56109597	1	Actuator (M5)
*	56109596	1	Plastic Nut
*	56109636	1	Spring Housing Kit
77	56109547	1	Spring Housing Bottom
78	56109546	1	Spring Housing Top
79	56420018	1	Compression Spring
80	56412071	1	Compression Spring
103	56219932	3	Clamp, Hose SAE #6
107	56009122	2	Wsh, Flt .344 x .938 x .125
108	56315839	1	Bracket Weld't only used after April 2007
109	56315836	1	Turnbuckle Assy only used after April 2007
110	56002063	3	Wsh, Flt SAE 3/8 only used after April 2007
111	56003120	2	Pin, Cotter Hair .0915 x .375 only used after April 2007

* = Not Shown

NOTE 1: The previous solution hose design which consisted of a Reducer (56418669), Hose Clamps (56219932) and a smaller 3/8" diameter Hose (56456830) to the scrub deck has been replaced in production with a single 1/2" diameter hose (56264318). If ordering this new hose (56264318) for a machine with the previous design you will also need to order a new Tee (56397300 for disc / 56262549 for cylindrical) for the scrub deck. See **NOTE 1** on **SCRUB SYSTEM – DISK (BA 625, BA 725)** and **SCRUB SYSTEM – CYLINDRICAL**.

NOTE 2: The previous Solution Tank Caps 56315517 & 56109519 are obsolete. The new Cap 56601599 can be used in place of the originals.

NOTE 3: This solution tank kit is to be ordered if you need to replace a solution tank on a machine before serial number 2059967.

NOTE 4: Actuator 56109595 replaces actuator 56396049 as of September 2009.

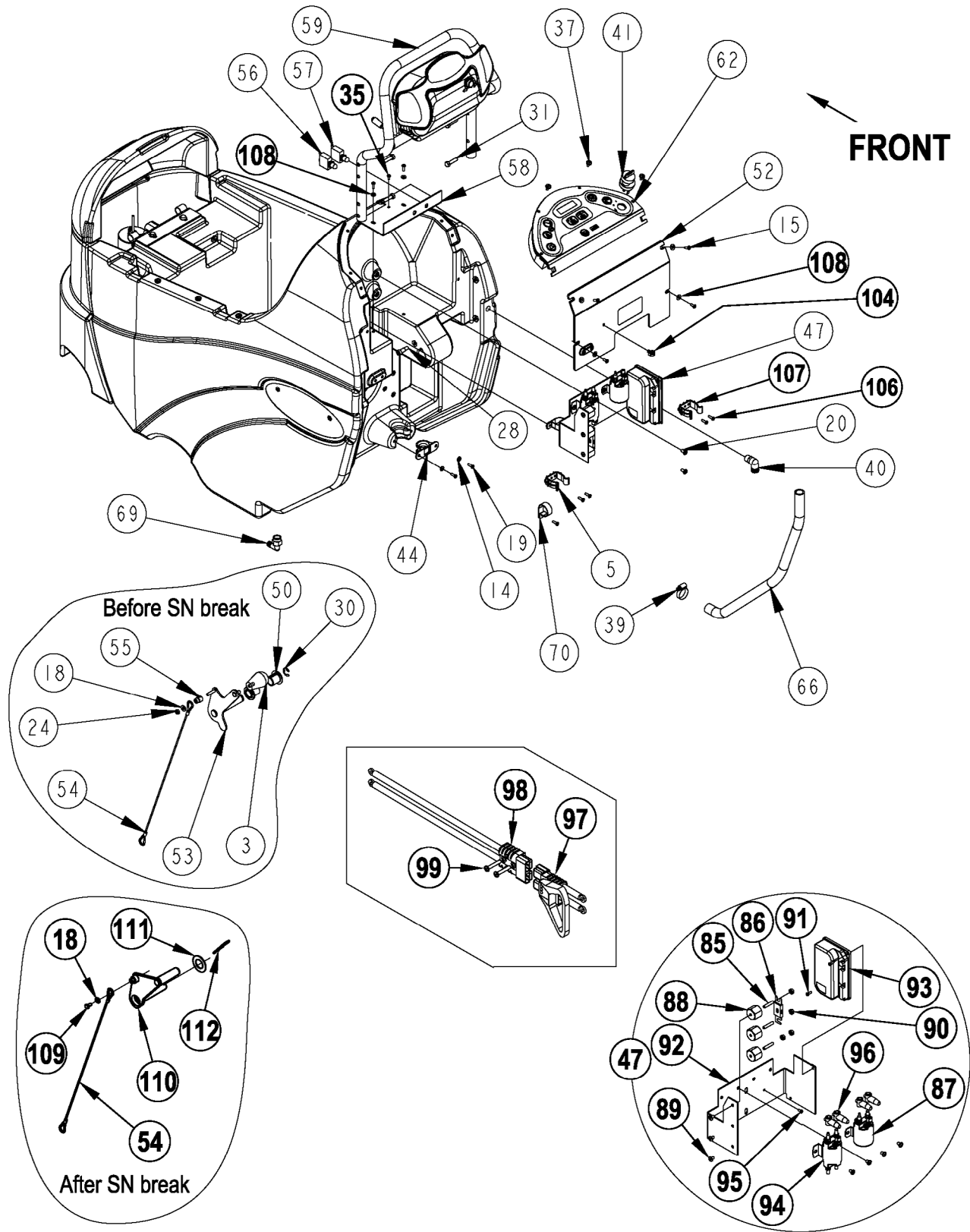

Item	Ref. No.	Qty	Description	Item	Ref. No.	Qty	Description
3	56364527	1	Knob NOTE 4	58	56109553	1	Plate, Circuit Breaker
5	56407361	1	Clamp, Plastic	59	56315266	1	Assembly, Paddle TSBUS2005-898
14	56001954	2	Wsh, Fit SAE #10	62	56315297	1	Control Panel Assy (A1) NOTE 1
15	56001993	4	Scr, Pan Phil 10-24x.50		56315777	1	Control Panel Assy (A1) NOTE 2
18	56002098	4	Wsh, Fit SAE 1/4	66	56396143	1	Hose, PVC
19	56002124	12	Scr, Pan Phil 10-24x.62	69	56409152	1	Barb, 90 Elbow 1/2 X 1/2NPT
20	56002145	5	Scr, Pan Phil 1/4-20x.50	70	56410166	2	Clamp, P
24	56002840	1	Nut, Hex Nyl Loc-Thin 1/4-20 NOTE 4	85	56009203	3	Stud, 1/4-20
28	56002962	1	Scr, Soc Shd .38 X .62 X 5/16-18 NOTE 4	86	56412089	1	Fuse, 150 Amp (F1)
30	56003266	1	Ring, Ret Ext Type E 0.75 Dia NOTE 4	87	56412179	1	Contactor, 24 Vdc (K2 / Vac Motor)
31	56002094	4	Scr, Hex Hd 5/16-18x1.50	88	56469858	3	Standoff, Insulated
35	56009030	1	Scr, Pan Phil Thd Form 10-24x.38	89	56002462	7	Scr, Pan Phil 1/4-20x.38
37	56009206	4	Scr, Truss Phil-Blk 10-24x.50	90	56002561	4	Nut, Hex W/ Shprf 1/4-20
39	56244969	1	Clamp, Hose SAE #12	91	56003698	2	Scr, Pan Phil Thd Form 8-32 x .75
40	56264442	1	Barb, 90 Ebow 3/4 X 3/8NPT	92	56315182	1	Panel, Electrical
41	56303553	1	Key Switch Assembly	93	56315294	1	Speed Control (A2)
*	56303526	A/R	Set of 2 Replacement Keys	94	56397088	1	Contactor, 24v Spdt (K1 / Brush Motor)
44	56315121	1	Guide, Cable	95	56009030	1	Scr, Pan Phil Thd Form 10-24x.38
47	56315162	1	Assy, Electrical Box (85-96) TSBUS2005-897 TSBUS2006-926	96	56409538	4	Insulator, Terminal
50	56315193	2	Bushing, Flange NOTE 4	97	56315345	1	Connector Assy (connected to batteries)
52	56109502	1	Panel, Electrical Assy	98	56397187	1	Connector Assy (connected to machine)
53	56315236	1	Weldment, Squeegee Lift NOTE 4	99	56002825	2	Scr, Pan Phil 1/4-20 x 1.25
54	56315243	1	Cable Assy	104	56315382	1	Clip, Conduit
55	56315245	1	Bushing, Squeegee Cable NOTE 4	106	56001993	2	Scr, Pan Phil 10-24 x .50
56	56315255	1	Circuit Breaker, 5 Amp	107	56212236	1	Clamp, Plastic
57	56315256	1	Circuit Breaker, 30 Amp	108	56002053	6	Wsh, Fit STD #10
				109	56001854	1	Scr, Hex 1/4-20 x .50 NOTE 5
				110	56315730	1	Lever, Squeegee Lift NOTE 5
				111	56009117	1	Wsh, Fit 1.031 x 1.859 x 0.48 NOTE 5
				112	56003223	1	Pin, Cot Hair.148 x Dia .62/1.00 NOTE 5

* = Not Shown

NOTE 1: Order this control panel assy if you have the "Old Pump" voltage reading across the solution pump (**M8**) leads.

NOTE 2: Order this control panel assy if you have the "New Pump" voltage reading across the solution pump (**M8**) leads.

	Voltage
Regular Scrub	
Old Pump	7
New Pump	9.56
Heavy Scrub	
Old Pump	11.3
New Pump	13.7
Extreme Scrub	
Old Pump	17
New Pump	19.24

NOTE 4: Used before SN 2059968. Items 50 and 53 are obsolete, to replace order each of the following part numbers 56001854, 56315730, 56009117, 56003223 (qty 1).

NOTE 5: Used after SN 2059967.

PADDLE ASSEMBLY

08-9

20

BA 625, BA 725, BA 825

09-8

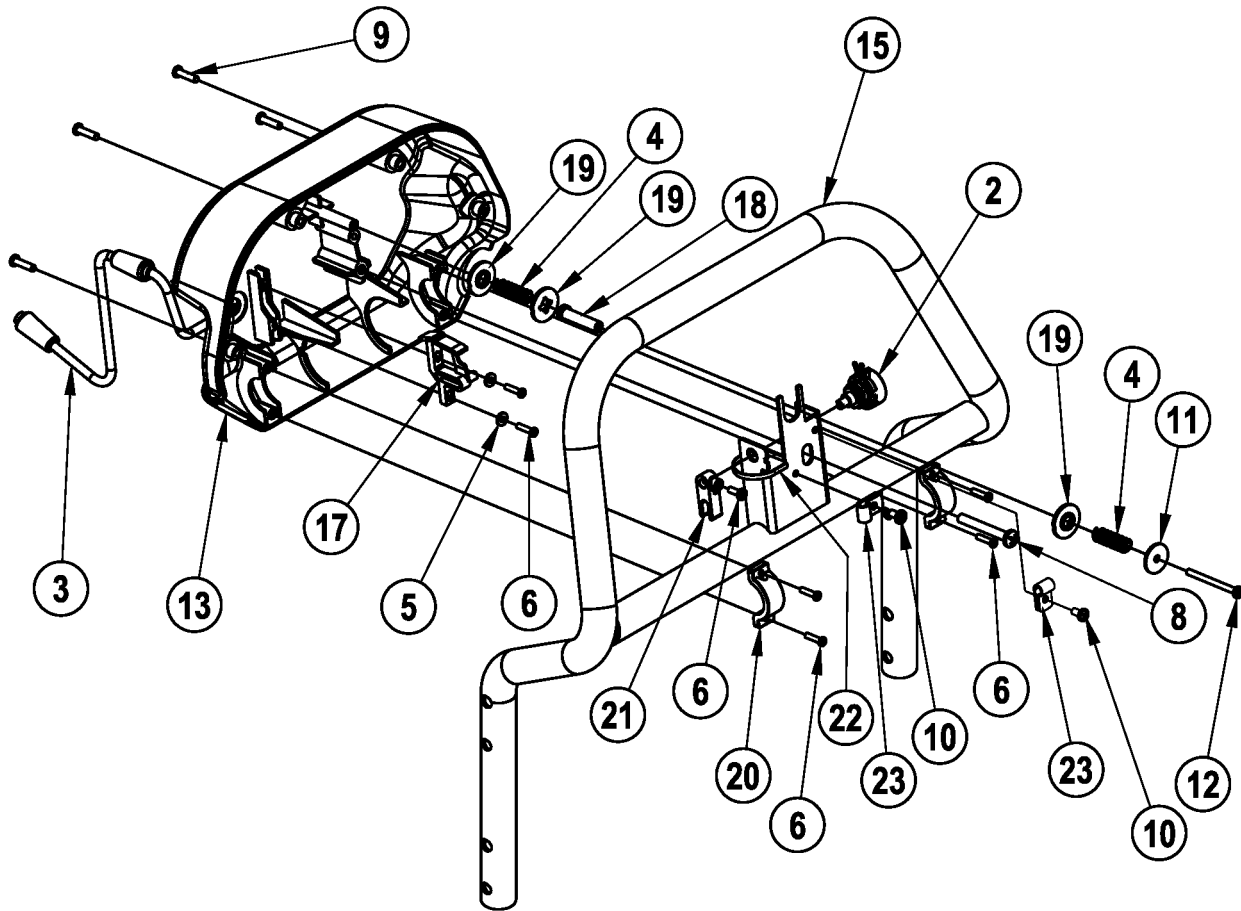

FRONT

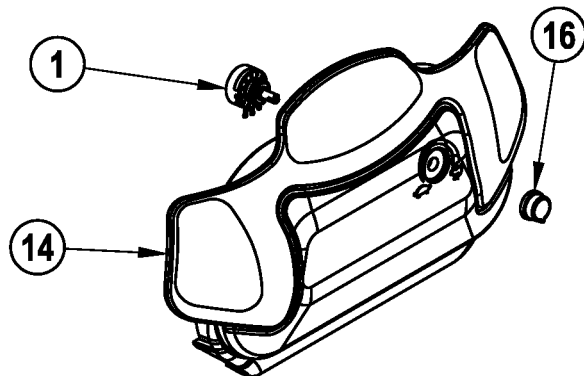

08-9	PADDLE ASSEMBLY		
09-12	BA 625, BA 725, BA 825		21

Item	Ref. No.	Qty	Description
	56315266	1	Assembly, Paddle TSBUS2005-898 / TSBUS2006-925
1	56396197	1	Potentiometer, 100k (R2)
2	56397029	1	Potentiometer, 5k (R1)
3	56315231	1	Harness, Handle
4	56325654	2	Spring, Compression
5	56002006	2	Wsh, Flt SAE #6
6	56003197	7	Scr, Pan Phil Plastite 6-18x.62
8	56003527	1	Scr, Pan Phil Plastite 1/4-10x2.00
9	56003545	4	Scr, Pan Phil Plastite 8-10x.75
10	56009030	2	Scr, Pan Phil Thd Form 10-24x.38
11	56009096	1	Wsh, Flt .193 X .875 X .060
12	56009287	1	Scr, Pan Phil Type B 8x2.00
13	56109716	1	Paddle, Back Cover
14	56315230	1	Paddle, Front Cover
15	56315251	1	Weldment, Handle Bar
16	56315280	1	Knob
17	56397015	1	Cam Controller
18	56397109	1	Sleeve
19	56397170	3	Washer, Plastic
20	56397171	2	Clamp
21	56109648	1	Potentiometer Fork
22	56478246	1	Tie, Cable
23	56481890	2	Clamp, P

SQUEEGEE ASSEMBLY

08-9

22

BA 625, BA 725, BA 825

09-8

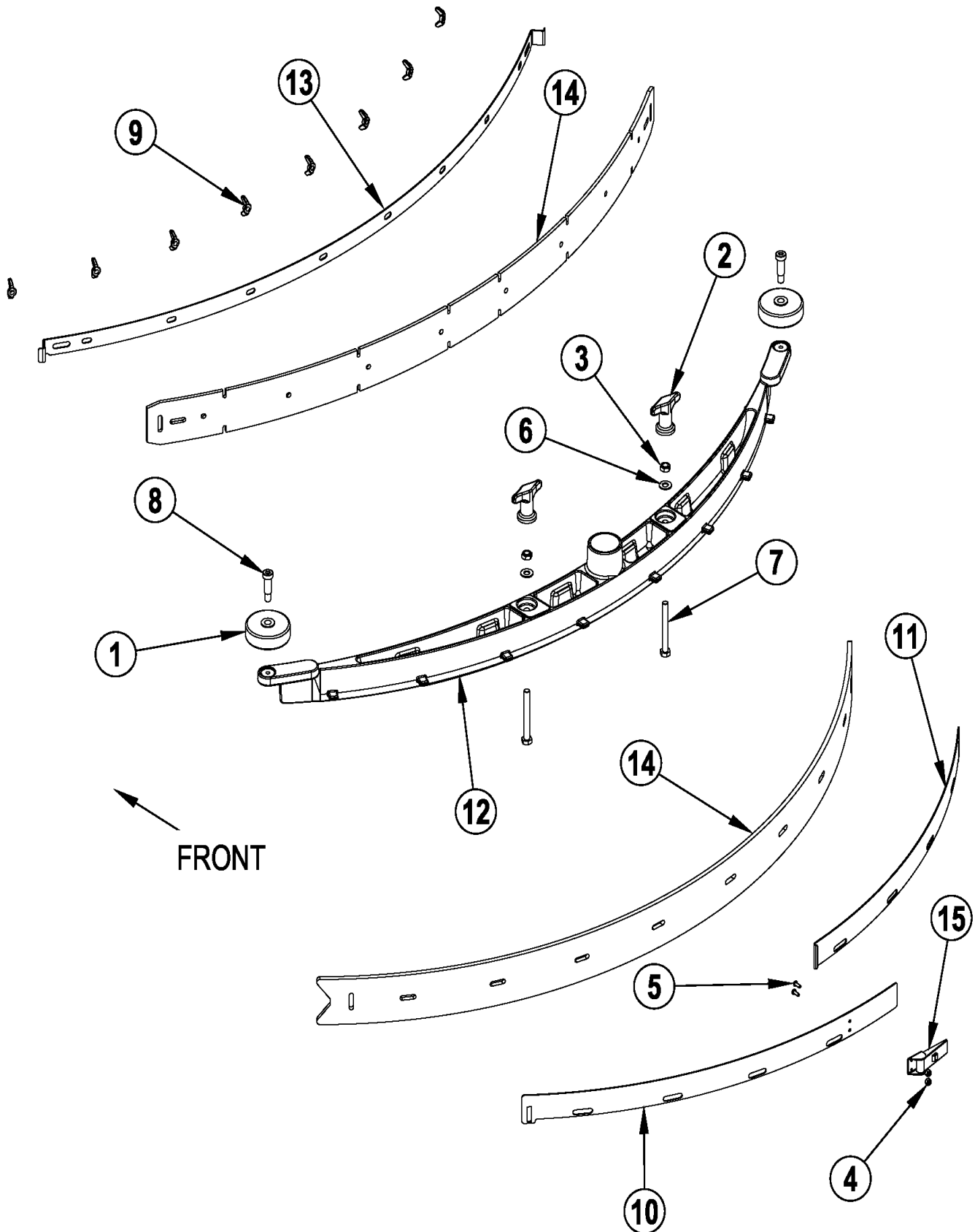

Item	Ref. No.	Qty	Description
	56315291	1	Squeegee Assembly "B" (BA 625) NOTE 2
	56315290	1	Squeegee Assembly "C" (BA 725) NOTE 2
	56315632	1	Squeegee Assembly "D" (BA 825) NOTE 2
1	56324350	2	Wheel
2	56370711	2	Nut, Thumb
3	56002851	2	Nut, Hex Nyl Loc-Thin SS 5/16-18
4	56002907	2	Nut, Hex Nyl Loc SS 6-32
5	56002909	2	Scr, Pan Phil SS 6-32x.38
6	56002938	2	Wsh, Flt SAE SS 5/16
7	56003736	2	Scr, Hex Thd to Hd SS 5/16-18 x 3.00
8	56003472	2	Scr, Soc Shd .38 X 1.00 X 5/16-18
9	56009111	6	Nut, Wing SS 1/4-20
10	56109660	1	Strap-Left Rear "B" (BA625) NOTE 2 / TSBUS2009-1037
	56109664	1	Strap-Left Rear "C" (BA725) NOTE 2 / TSBUS2009-1037
	56109667	1	Strap-Left Rear "D" (BA825) NOTE 2 / TSBUS2009-1037
11	56109661	1	Strap-Right Rear "B" (BA625) NOTE 2 / TSBUS2009-1037
	56109665	1	Strap-Right Rear "C" (BA725) NOTE 2 / TSBUS2009-1037
	56109668	1	Strap-Right Rear "D" (BA825) NOTE 2 / TSBUS2009-1037
12	56314271	1	Squeegee Tool, Cast "B" (BA 625)
	56314325	1	Squeegee Tool, Cast "C" (BA 725)
	56314694	1	Squeegee Tool, Cast "D" (BA 825)
13	56314028	1	Strap, Front "B" (BA 625) NOTE 2
	56314322	1	Strap, Front "C" (BA 725) NOTE 2
	56314696	1	Strap, Front "D" (BA 825) NOTE 2
14	56315347	1	Squeegee Blade kit (BA 625) NOTE 1
	56315348	1	Squeegee Blade kit (BA 725) NOTE 1
	56315674	1	Squeegee Blade kit (BA 825) NOTE 1
15	56471194	1	Latch Assembly / TSBUS2009-1037
			BA 625 Squeegee Blade Kits
**	56315347	1	Kit, Gum Rubber Squeegee Blade NOTE 1
**	56315351	1	Kit, Linatex Squeegee Blade NOTE 1
**	56315854	1	Kit, Squeegee Blade PU B NOTE 1
			BA 725 Squeegee Blade Kits
**	56315348	1	Kit, Gum Rubber Squeegee Blade NOTE 1
**	56315352	1	Kit, Linatex Squeegee Blade NOTE 1
**	56315855	1	Kit, Squeegee Blade PU C NOTE 1
			BA 825 Squeegee Blade Kits
**	56315674	1	Kit, Gum Rubber Squeegee Blade NOTE 1
**	56314865	1	Kit, Linatex Squeegee Blade NOTE 1
**	56315856	1	Kit, Squeegee Blade PU D NOTE 1

** = Optional, Not Included

NOTE 1: All squeegee blade kits include both front and rear squeegee blades

NOTE 2: To replace all squeegee straps as a set

order one of the three following Strap Kits:

56109669-Strap Kit-D (for Squeegee Assy 56315632)

56109666-Strap Kit-C (for Squeegee Assy 56315290)

56109662-Strap Kit-B (for Squeegee Assy 56315291)

These kits include both rear straps, front strap and the latch.

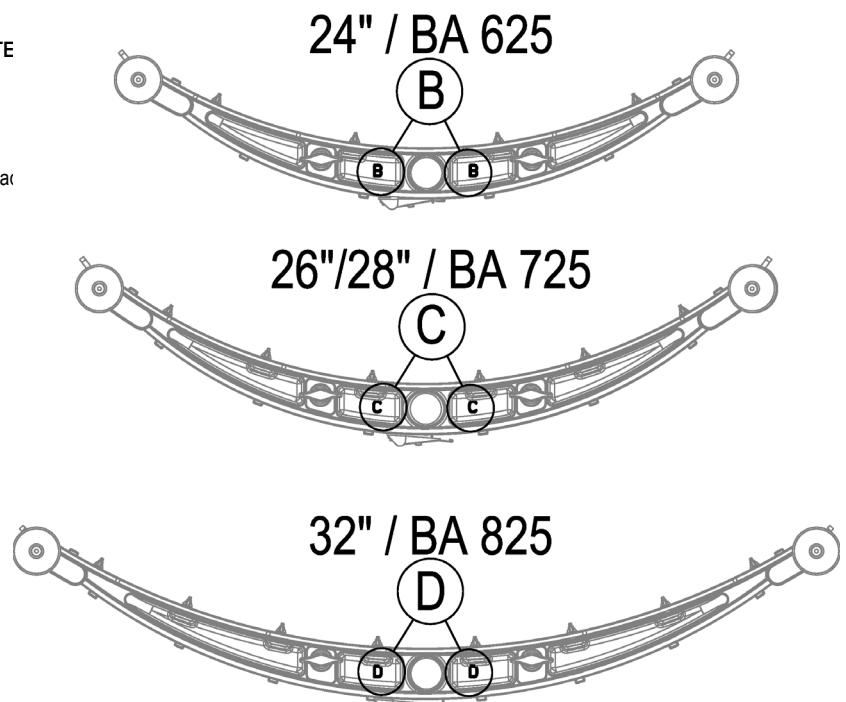

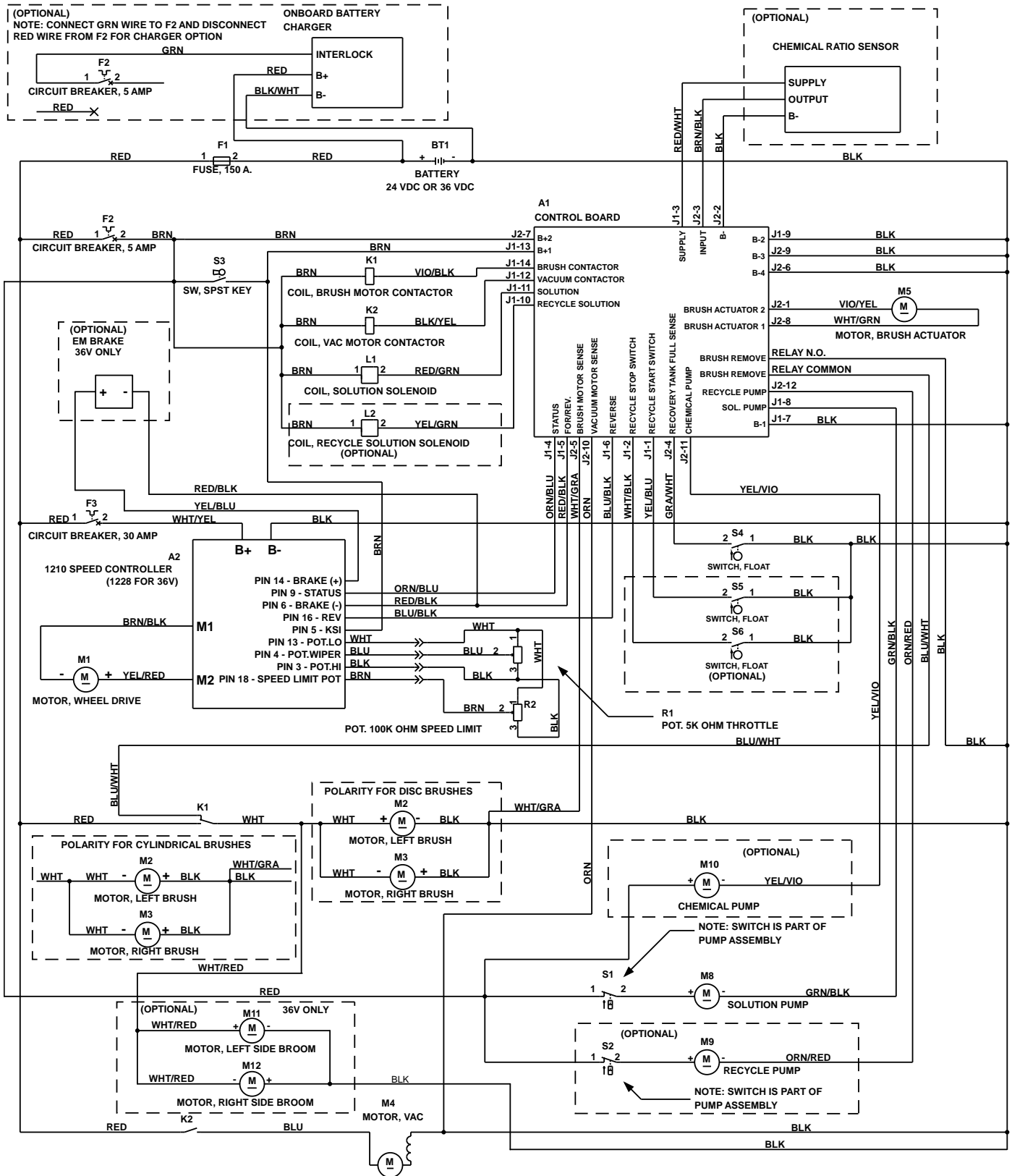

REFERENCE: WIRING DIAGRAM 56315302 FOR 24V
WIRING DIAGRAM 56315596 FOR 36V

56016691-REV. E

08-9	WIRING DIAGRAM (before September 2009)		
10-9	BA 625, BA 725, BA 825		25

Item	Ref. No.	Qty	Description	Item	Ref. No.	Qty	Description
A1	56315297	1	Control Panel Assy (A1) NOTE 1	*	56315124	1	Charger, Onboard 24V (Optional)
	56315777	1	Control Panel Assy (A1) NOTE 2	*	56315747	1	Thermistor Repair Kit for 56315124
A2	56315294	1	Speed Control	*	56315340	1	Chemical Ratio Sensor (Optional)
BT1	NA	4	Battery	*	56315249	1	Harness, Main TSBUS2006-926 / TSBUS2007-955
F1	56412089	1	Fuse, 150 Amp	*	56315751	1	Vacuum Harness TSBUS2007-955
F2	56315255	1	Circuit Breaker, 5 Amp	*	56416445	3	Cable Assy 4 AWG (Battery Cables)
F3	56315256	1	Circuit Breaker, 30 Amp	*	56372673	8	Boot, Battery Post
K1	56397088	1	Contactora, Brush Motor	*	56478523	2	Tie, Cable
K2	56412179	1	Contactora, Vac Motor	*	56478246	9	Tie, Cable
L1	56397203	1	Solenoid, Solution	*	56314119	1	Spacer. Battery
L2	56397203	1	Solenoid, Recycle Solution (Optional)	*	56315838	2	Harness, Filter
M1	56315062	1	Transaxle, 24v	*	56413883	2	Ferrite Bead Disk models only
*	56315377	1	Motor	* = Not Shown			
*	56315378	4	Carbon Brush				
*	56315379	2	Neoprene Mounting Sleeve				
M2	56315056	1	Motor, Left Brush (Disk)				
*	56315376	4	Carbon Brush				
*	56397138	4	Brush Spring				
	56315061	1	Motor, Left Brush (Cylindrical) TSBUS2010-1058				
*	56412287	1	Brush / Spring Kit				
M3	56315056	1	Motor, Right Brush (Disk)				
*	56315376	4	Carbon Brush				
*	56397138	4	Brush Spring				
	56315061	1	Motor, Left Brush (Cylindrical) TSBUS2010-1058				
*	56412287	1	Brush / Spring Kit				
M4	56412300	1	Motor, Vac				
*	56397098	1	Carbon Brush set of 2 (for 56412300) NOTE 3				
*	56380529	1	Carbon Brush set of 2 (for 56412300) NOTE 3				
M5	56393303	1	Motor, Brush Actuator				
*	56388520	1	Plastic Nut (for use on 56393303)				
M8	56315108	1	Pump, Solution				
M9	56315132	1	Pump, Recycle (Optional)				
M10	56315241	1	Pump, Chemical (Optional)				
R1	56397029	1	Potentiometer, 5K Ohm, Throttle				
R2	56396197	1	Potentiometer, 100K Ohm, Speed Limit				
S1	NA	1	Part of M7				
S2	NA	1	Part of M8				
S3	56303553	1	Switch, Key				
*	56303526	A/R	Set of 2 Replacement Keys				
S4	56315096	1	Switch, Float				
S5	56315096	1	Switch, Float (Optional / Recycle Start)				
S6	56315096	1	Switch, Float (Optional / Recycle Stop)				

NOTE 1: Order this control panel assy if you have the "Old Pump" voltage reading across the solution pump (M8) leads.

NOTE 2: Order this control panel assy if you have the "New Pump" voltage reading across the solution pump (M8) leads.

	Voltage
Regular Scrub	
Old Pump	7
New Pump	9.56
Heavy Scrub	
Old Pump	11.3
New Pump	13.7
Extreme Scrub	
Old Pump	17
New Pump	19.24

NOTE 3: If your vacuum motor has a serial tag from Lamb Electric (Ametek) order Carbon Brush Set 56397098.

If your vacuum motor has a serial tag from Nilfisk-Advance order Carbon Brush Set 56380529.

08-9	WIRING DIAGRAM (after August 2009)		
10-9	BA 625, BA 725, BA 825		27

Item	Ref. No.	Qty	Description	Item	Ref. No.	Qty	Description
A1	56315777	1	Control Panel Assy (A1)	*	56315124	1	Charger, Onboard 24V (Optional)
A2	56315294	1	Speed Control	*	56315747	1	Thermistor Repair Kit for 56315124
BT1	NA	4	Battery	*	56315340	1	Chemical Ratio Sensor (Optional)
F1	56412089	1	Fuse, 150 Amp	*	56315249	1	Harness, Main TSBUS2006-926 / TSBUS2007-955
F2	56315255	1	Circuit Breaker, 5 Amp	*	56315751	1	Vacuum Harness TSBUS2007-955
F3	56315256	1	Circuit Breaker, 30 Amp	*	56416445	3	Cable Assy 4 AWG (Battery Cables)
K1	56397088	1	Contactora, Brush Motor	*	56372673	8	Boot, Battery Post
K2	56412179	1	Contactora, Vac Motor	*	56478523	2	Tie, Cable
L1	56397203	1	Solenoid, Solution	*	56478246	9	Tie, Cable
M1	56315062	1	Transaxle, 24v	*	56314119	1	Spacer, Battery
*	56315377	1	Motor	*	56315838	2	Harness, Filter
*	56315378	4	Carbon Brush	*	56413883	2	Ferrite Bead Disk models only
*	56315379	2	Neoprene Mounting Sleeve				
M2	56315056	1	Motor, Left Brush (Disk)	* = Not Shown			
*	56315376	4	Carbon Brush				
*	56397138	4	Brush Spring				
	56315061	1	Motor, Left Brush (Cylindrical) TSBUS2010-1058				
*	56412287	1	Brush / Spring Kit (for 56315061) NOTE 2				
*	56380003	1	Brush / Spring Kit (for 56315061) NOTE 2				
M3	56315056	1	Motor, Right Brush (Disk)				
*	56315376	4	Carbon Brush				
*	56397138	4	Brush Spring				
	56315061	1	Motor, Left Brush (Cylindrical) TSBUS2010-1058				
*	56412287	1	Brush / Spring Kit (for 56315061) NOTE 2				
*	56380003	1	Brush / Spring Kit (for 56315061) NOTE 2				
M4	56412300	1	Motor, Vac				
*	56397098	1	Carbon Brush set of 2 (for 56412300) NOTE 1				
*	56380529	1	Carbon Brush set of 2 (for 56412300) NOTE 1				
M5	56109597	1	Motor, Brush Actuator				
*	56109596	1	Plastic Nut (for use on 56109597)				
M8	56315108	1	Pump, Solution				
M10	56315241	1	Pump, Chemical (Optional)				
R1	56397029	1	Potentiometer, 5K Ohm, Throttle				
R2	56396197	1	Potentiometer, 100K Ohm, Speed Limit				
S1	NA	1	Part of M8				
S3	56303553	1	Switch, Key				
*	56303526	A/R	Set of 2 Replacement Keys				
S4	56315096	1	Switch, Float				

NOTE 1: If your vacuum motor has a serial tag from Lamb Electric (Ametek) order Carbon Brush Set 56397098.

If your vacuum motor has a serial tag from Nilfisk-Advance order Carbon Brush Set 56380529.

NOTE 2: If your cylindrical scrub motor has a serial tag from Scott Motors Co. (4BB1344) order Carbon Brush Set 56412287.

If your cylindrical scrub motor has a serial tag from Nilfisk-Advance (ZD22000) order Carbon Brush Set 56380003.

OPTIONAL KITS AND ACCESSORIES

08-9

28

BA 625, BA 725, BA 825

11-1

Ref. No.	Qty	Description	Ref. No.	Qty	Description
Kits			BA 725 Disk Scrub Brushes		
**	56315312	1 Squeegee Wand Kit	**	56505800	2 Short Trim Pad Holder
**	56315732	1 QuiQ Programmer Kit NOTE 2 TSBUS2007-979	**	56505195	2 Pad Retainer for 56505750
**	56315860	A/R Kit, BA625 Disk Deck W/Squeegee	**	56505801	2 MagnaGrit
**	56315861	A/R Kit, BA725 Disk Deck W/Squeegee	**	56505802	2 DynaGrit
**	56315863	A/R Kit, BA825 Disk Deck W/Squeegee	**	56505803	2 AgLite
**	56315862	A/R Kit, BA725 Cyl Deck W/Squeegee	**	56505804	2 Prolene
**	56315845	1 EDS On-Board Chemical Kit	**	56505805	2 ProLite
**	56315846	1 On-Board Charger kit-EU	**	56505806	2 Union Mix
BA 625 Squeegee Kits			**	56505807	2 MidGrit
**	56315347	1 Kit, Gum Rubber Squeegee Blade NOTE 1	**	56505808	2 MidLite Grit
**	56315351	1 Kit, Linatex Squeegee Blade NOTE 1	BA 825 Disk Scrub Brushes		
**	56315854	1 Kit, Squeegee Blade PU B NOTE 1	**	56505830	2 Short Trim Pad Holder
**	56109662	1 Strap Kit-B	**	56505195	2 Pad Retainer for 56505750
BA 725 Squeegee Kits			**	56505831	2 MagnaGrit
**	56315348	1 Kit, Gum Rubber Squeegee Blade NOTE 1	**	56505832	2 DynaGrit
**	56315352	1 Kit, Linatex Squeegee Blade NOTE 1	**	56505833	2 AgLite
**	56315855	1 Kit, Squeegee Blade PU C NOTE 1	**	56505834	2 Prolene
**	56109666	1 Strap Kit-C	**	56505835	2 ProLite
BA 825 Squeegee Kits			**	56505836	2 Union Mix
**	56315674	1 Kit, Gum Rubber Squeegee Blade NOTE 1	**	56505837	2 MidGrit
**	56314865	1 Kit, Linatex Squeegee Blade NOTE 1	**	56505838	2 MidLite Grit
**	56315856	1 Kit, Squeegee Blade PU D NOTE 1	BA 725 Cylindrical Scrub Brushes		
**	56109669	1 Strap Kit-D	**	56412191	2 Soft Nylon
Accessories			**	56412192	2 Hard Nylon
**	56315316	A/R Tote Bag	**	56412046	2 Prolene
**	56409441	A/R Programmer, 1307 User	**	56412193	2 180 Grit
**	56409823	A/R Programmer Cable	**	56412194	2 80 Grit
**#	56044403	1 Literature Pack	**	56412195	2 46 Grit
Optional Batteries			* = Not Shown		
*	80567300	1 Battery, Complete 24v 174 A/H (set of 4)	** = Optional, Not Included		
*	80566500	1 Battery, Complete 24v 180 A/H (set of 4)	# = Revised or new since last update		
*	80564500	4 Battery, 6v 174 A/H	NOTE 1: All squeegee blade kits include both front and rear squeegee blades.		
*	80564000	4 Battery, 6v 180 A/H	NOTE 2: Starting with Charger serial # CP240548022382 the charger software can be programmed with a computer and the QuiQ Programmer kit 56315732.		
Optional Battery Chargers					
*	80568700	1 Charger, 24vdc, 20 Amp, 230vac (UK)			
*	80568400	1 Charger, 24vdc, 20 Amp, 230vac (EU)			
BA 625 Disk Scrub Brushes					
**	56505750	2 Short Trim Pad Holder			
**	56505195	2 Pad Retainer for 56505750			
**	56505751	2 MagnaGrit			
**	56505752	2 DynaGrit			
**	56505753	2 AgLite			
**	56505754	2 Prolene			
**	56505755	2 ProLite			
**	56505756	2 Union Mix			
**	56505757	2 MidGrit			
**	56505758	2 MidLite Grit			

We provide brushes and pad holders that will give you the best possible performance between machine and floor. Following are descriptions of the materials and their applications.

Union Mix:	Medium grade natural fibers for polishing finished floors with standard-speed equipment. Recommended for use in place of white pads.
ProLite:	Bristles are made from light-duty polypropylene for general scrubbing when you do not want to scratch or remove finish from the floor. Recommended for use in place of red pads.
Prolene:	Polypropylene material for medium-duty scrubbing on concrete, terrazzo and vinyl floor tile. Recommended for use in place of green or blue pads.
Magna Grit:	For extreme heavy-duty scrubbing or stripping of floors. This brush has extra large diameter silicon carbide grit impregnated synthetic bristles. Recommended for use in place of black pads.
Dyna Grit:	For aggressive, heavy-duty scrubbing or stripping of floors. Recommended for use in place of brown pads.
MidLite Grit:	For general purpose scrubbing of sealed or unsealed concrete, stone, terrazzo, quarry tile and other resilient hard floor surfaces. Recommended for use in place of green or blue pads.
MidGrit:	For general purpose scrubbing when you need a lighter action for sealed or unsealed concrete, stone, terrazzo, quarry tile and other resilient hard floor surfaces. Recommended for use in place of green or blue pads.
AgLite Grit:	For light scrubbing when used wet; buffing or polishing when used dry on urethane coated, sealed concrete or other resilient hard surface floors. Recommended for use in place of red or white pads.
Short Trim	
Pad Holder:	Made with a structural foam block and center ring for correct pad centering. It has a "shower feed" design for getting solution to the floor.

BA 625 BRUSHES

56505750 - Short Trim Pad Holder
 56505195 - Pad Retainer for 56505750
 56505751 - MagnaGrit
 56505752 - DynaGrit
 56505753 - AgLite
 56505754 - Prolene
 56505755 - ProLite
 56505756 - Union Mix
 56505757 - MidGrit
 56505758 - MidLite Grit

BA 725 BRUSHES

56505800 - Short Trim Pad Holder
 56505195 - Pad Retainer for 56505800
 56505801 - MagnaGrit
 56505802 - DynaGrit
 56505803 - AgLite
 56505804 - Prolene
 56505805 - ProLite
 56505806 - Union Mix
 56505807 - MidGrit
 56505808 - MidLite Grit

BA 825 BRUSHES

56505830 - Short Trim Pad Holder
 56505195 - Pad Retainer for 56505800
 56505831 - MagnaGrit
 56505832 - DynaGrit
 56505833 - AgLite
 56505834 - Prolene
 56505835 - ProLite
 56505836 - Union Mix
 56505837 - MidGrit
 56505838 - MidLite Grit

DISC BRUSH APPLICATION GUIDE (SUGGESTION ONLY)

Application	46 Grit	80 Grit	180 Grit	240 Grit	500 Grit	Prolene	Prolite	Union Mix
Stripping:								
Concrete	X	X						
Terrazzo	X	X						
Ceramic/Quarry tile		X						
Vinyl tile		X						
General Scrubbing:								
Concrete	X	X	X	X		X		
Terrazzo			X	X	X	X		
Ceramic/Quarry tile			X	X	X	X		
Marble					X		X	
Vinyl tile			X		X	X		
Raised-rubber tile					X		X	
Polishing:								
Raised Disc Tile								X
Marble								X
Vinyl tile								X

We provide brushes and pad holders that will give you the best possible performance between machine and floor. Following are descriptions of the materials and their applications.

- 46 Grit Brush: Most aggressive grit brush. Used primarily to clean heavy buildup on concrete floors in factories, or for heavy stripping of finish.
- 80 Grit Brush: Medium aggressive grit brush. Good all-around brush for medium to heavy buildup removal. Can also be used for general stripping operations.
- 180 Grit Brush: Least aggressive grit brush. Used for daily cleaning of hard-finished floors.
- Polypropylene Brush: Standard equipment brush. Low cost, yet effective in cleaning many common floor surfaces.
- Stiff Nylon Brush: Cleaning action similar to polypropylene. More durable and wear-resistant than polypropylene.
- Soft Nylon Brush: Least aggressive brush available. Used on soft-finish floors where a more aggressive brush would leave scratch marks, or in applications requiring very light cleaning.

BA 725 BRUSHES

- 56412191 - Soft Nylon
- 56412192 - Hard Nylon
- 56412046 - Prolene
- 56412193 - 180 Grit
- 56412194 - 80 Grit
- 56412194 - 46 Grit

CYLINDRICAL BRUSH APPLICATION GUIDE (SUGGESTION ONLY)

Application	46 Grit	80 Grit	180 Grit	Polypropylene	Stiff Nylon	Soft Nylon
Stripping:						
Concrete	X	X				
Terrazzo	X	X				
Ceramic/Quarry tile		X				
Vinyl tile		X				
General Scrubbing:						
Concrete	X	X	X	X	X	
Terrazzo			X	X	X	X
Ceramic/Quarry tile			X	X	X	X
Marble			X		X	X
Vinyl tile			X	X	X	X
Raised-rubber tile			X			X



Nilfisk
setting standards

Nilfisk-Advance A/S
Sognevej 25
DK-2605 Brøndby
Denmark
Tel: +45 43 23 81 00
Fax: +45 43 43 77 00
www.nilfisk-advance.com