

# 7730

Battery Powered Rider Sweeper-Scrubber



Smart cleaning.

A Nilfisk-Advance Brand

 **Advance**  
Industrial Cleaning Equipment

Battery compartment offers easy access for daily maintenance.

Deeply padded seat, power steering and tilt steering wheel provide top-of-the-line comfort.

Corrosion-proof, impact-resistant polyethylene solution and recovery tanks protect your investment.

Dust control system prevents stirring up even the finest dust while sweeping.

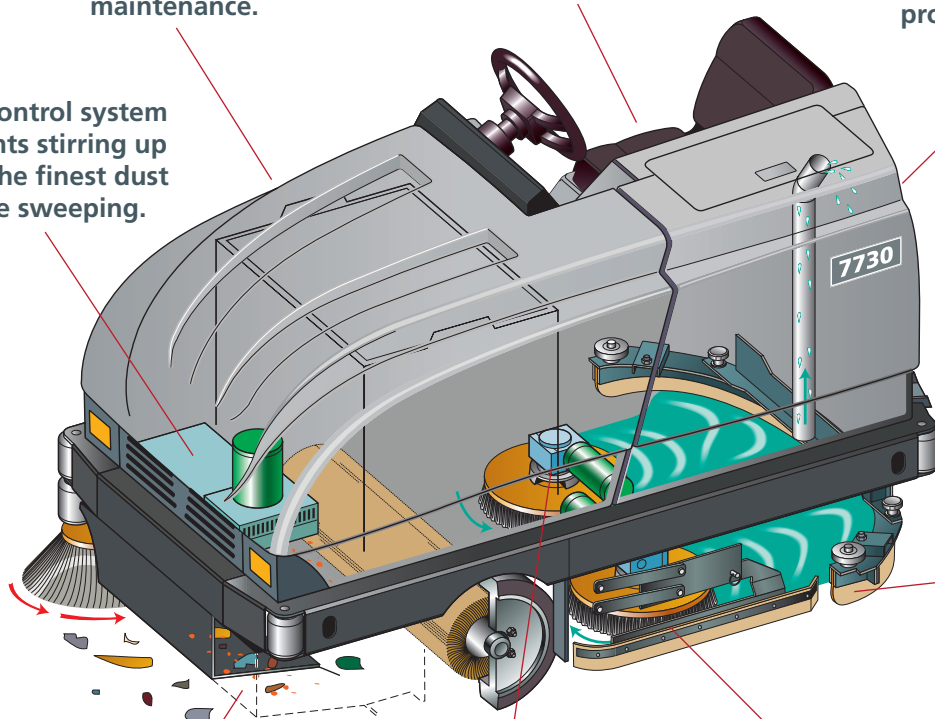

Accu-Track™ squeegee provides superior water pickup even during the tightest turns and with no-tool squeegee change, maintenance is a snap.

Independent dry sweeping system picks up dirt and debris before scrubbing.

A variety of brushes accommodates your cleaning needs.

Heavy-duty, high torque 1.7 h.p. brush drive motors aggressively clean the dirtiest floors.



Double-scrub disc brushes offer the most aggressive cleaning action with quick, no-tool changing in minutes.

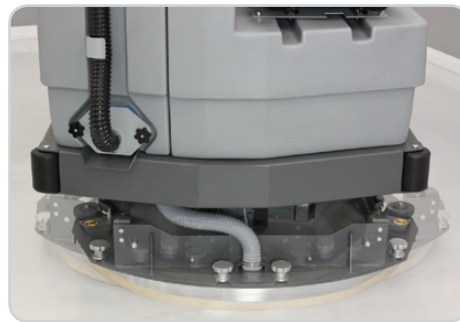

Accu-Track™ squeegee provides superior water pickup even during the tightest turns and no-tool changing for easy maintenance.



Large capacity batteries last for hours of cleaning and a quick and easy roll-on, roll-off battery changing system reduces downtime.

# 7730 Battery Powered Rider Sweeper-Scrubber

*Ideal applications include:*

## Reliable, Productive Sweeping and Scrubbing

The Advance 7730 is a powerful and reliable sweeper-scrubber that is sure to increase your cleaning productivity. This machine easily fits into small areas, yet with its large capacity hopper and solution tanks can clean up to 70,000 square feet per hour effortlessly. If you are looking for high-quality, efficient cleaning the 7730 offers both without the emissions and maintenance of an engine.

- Manufacturing Plants
- Discount Warehouses
- Food Warehouses
- Parking Garages
- Automotive Plants

### Innovative Key Features:

- Patented Accu-Track™ squeegee system leaves a clean, dry floor even in the tightest turns
- Dynamic, regenerative electric drive motor enhances reliability
- Standard roll-on, roll-off battery changing system offers increased productivity



Dust control option provides dust-free sweeping before debris enters the scrubbing area.



Reliable rocker switches and a tilt steering wheel result in easy-to-use controls and low maintenance costs.

### FEATURES AND BENEFITS

**Productivity** – Two machines in one – sweeper and scrubber. Powerful dust control system. Simple drain and clean-out system. Roll-on, roll-off battery change system. Powerful electric drive and power steering system. Large solution/recovery tanks to stay on the floor longer between cleanups. One-pass sweeping and scrubbing cleans up to 70,000 square feet per hour. Solution and brushes turn off when machine is not moving.

**Durability** – Sevcon traction drive controller. Heavy gauge welded steel chassis. Corrosion-proof Polydur® solution/recovery tanks. Accu-Track™ break-away squeegee. Durable corner roller bumpers for side protection.

**Safety Features** – Dead man seat with traction lockout. Controlled directional drive. Better handling with rack and pinion power steering. Excellent front and rear view for operator.



## Technical Specifications

Model	7730
Sweep Path	36 in (91 cm) or 46 in (117 cm)
Hopper Capacity	2.5 ft <sup>3</sup> (71 L)
Scrub Path	40 in (101 cm) or 46 in (117 cm)
Brush Sizes	(2) 20 in (51 cm) or (3) 16 in (40.6 cm)
Brush Speed	210 rpm
Brush Motors	1.7 hp heavy-duty, angled gear motor
Solution Tank	55 gal (170 L)
Recovery Tank	55 gal (170 L)
Vacuum Motor (2)	1 hp, 3-stage tangential discharge
Transport Speed	0 – 4.6 mph (0 – 7.4 kph)
Cleaning Speed	0 – 2.7 mph (0 – 4.3 kph)
Drive Motor	2.7 hp (2,000 W)
Aisle U-turn	87 in (221 cm)
Size (LxWxH)	87 x 46 x 52 in (221 x 116.8 x 132 cm) squeegee width 48 in (122 cm)
Weight (w/o batteries)	1,700 lb (765 kg)

Specifications are subject to change without notice.

### Standard Features:

- Powerful electric drive and power steering system
- Large solution/recovery tanks to stay on the floor longer between cleanups
- Sevcon traction drive controller
- Heavy gauge welded steel chassis
- Corrosion-proof Polydur® solution/recovery tanks
- Accu-Track™ break-away squeegee
- Durable corner roller bumpers for side protection
- Dead man seat with traction lockout
- Controlled directional drive
- Rack and pinion power steering

14600 21st Avenue North  
Plymouth, MN 55447-3408  
www.advance-us.com  
Phone 800-214-7700  
Fax 800-989-6566

240 Superior Boulevard  
Mississauga, Ontario, Canada L5T 2L2  
www.nilfisk-advance.com  
Phone 800-668-8400  
Fax 800-263-5111

Ask about our leasing options.

©2009 Nilfisk-Advance, Inc. Form L3100A 6-15-09



 **Advance**  
Industrial Cleaning Equipment

A Nilfisk-Advance Brand

www.advance-us.com/industrial