

Whirlamatic™ UHS20



PARTS LIST

**Advance MODELS 56183700(115V)
56183701(100V/OBSOLETE), 56183705(230V)**

This parts list is for machines after serial number 286668



Advance
by Nilfisk-Advance

revised 5/07 FORM NO. 56042186

<u>DESCRIPTION</u>	<u>PAGE</u>
HANDLE ASSEMBLY-FRONT VIEW	2-3
HANDLE ASSEMBLY-REAR VIEW	4-5
BASE ASSEMBLY	6-7
WIRING DIAGRAMS.....	8-9

WHEN ORDERING PARTS

- * Use the 8 digit numbers from the "Ref. No." columns in this parts list.
- * Specify the model and serial number of the machine.
- * Use the space below to record the model and serial number for future reference.

Model _____ Serial No. _____

HANDLE ASSEMBLY-FRONT VIEW

2

Whirlamatic™ UHS20

00-2

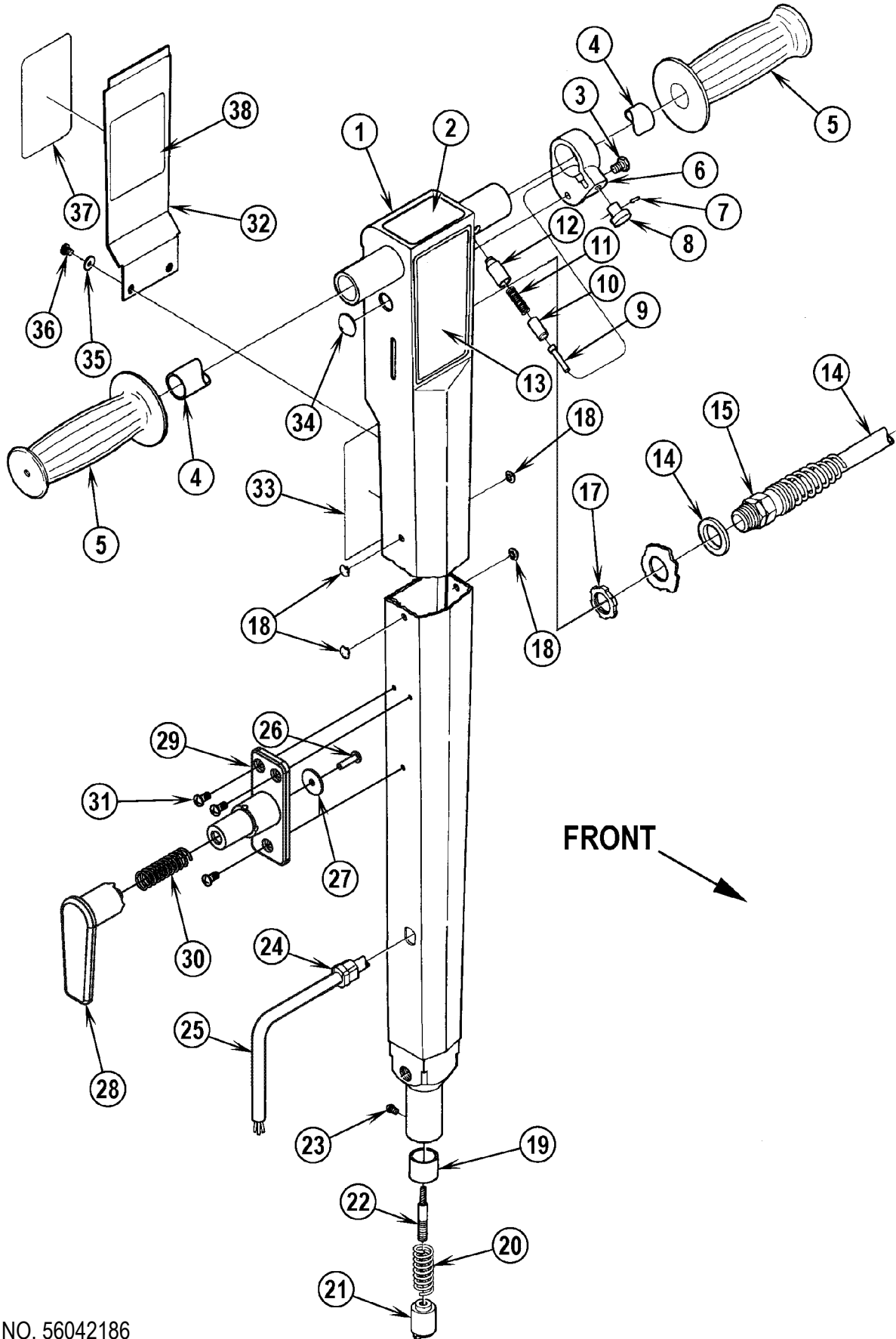

HANDLE ASSEMBLY-FRONT VIEW

07-5

Whirlamatic™ UHS20

3

Item	Ref. No.	Qty	Description
	56183725	1	Handle Assembly 100Vac
	56183133	1	Handle Assembly 115Vac
	56183132	1	Handle Assembly 220-240Vac
1	56183129	1	Handle 100, 115Vac
	56183135	1	Handle 220-240Vac
2	56014924	1	Decal, Warning 100, 115Vac
3	56001854	1	1/4-20 x 1/2 Screw
4	56171343	1	Handle Tube 100, 115Vac
	56183498	1	Handle Tube 220-240Vac
5	56388545	2	Hand Grip 100, 115Vac
	56900248	2	Hand Grip 220-240Vac
6	56172275	1	Collar
	56172321	1	Collar Assembly (#6-9)
7	56003129	1	Spring Pin
8	56201405	1	Knob
9	56172217	1	Pin
10	56171279	1	Plunger
11	56201448	1	Spring
12	56171281	1	Bushing
13	56016439	1	Decal, Logo
14	56180116	1	Cord Set 100Vac
	56524069	1	Cord Set 115Vac (50 ft)
	56183141	1	Cord Set 115V (75 ft)
	56183587	1	Cord Set 220-240Vac
15	56109630	1	Strain Relief 100, 115Vac
*	56109632	1	Brass Insert (for 56109630)
	56323136	1	Strain Relief 220-240Vac
16	56171093	1	Washer 100, 115Vac
17	56009095	1	Nut, Conduit Lock 1/2-14
18	56153699	4	Button Plug
19	56171269	1	Bushing
20	56171361	1	Spring
21	56171132	1	Plunger
22	56171373	1	Cable
23	56001851	1	#4-40 x 1/4 Screw
24	56382818	1	Strain Relief 100, 115Vac
	56163015	1	Strain relief 220-240Vac
25	56183003	1	Cord Set 100, 115Vac
	56183585	1	Cord Set 220-240Vac
	56171112	1	Cord Hook Assembly (#26-30)
26	56009005	1	Scr, Pan Phil SS Type B 10-16 x .75
27	56009096	1	Wsh Flt .193 x .875 x .060
28	56171110	1	Arm
29	56171111	1	Base
30	56380732	1	Spring
31	56009030	3	Scr, Pan Phil Thd Form 10-24 x .38
32	56172273	1	Cover 100, 115Vac
	56183611	1	Cover 220-240Vac
33	56014828	1	Decal, Warning 100, 115Vac
	56014204	1	Decal, Warning 220-240Vac
34	56322231	2	Button Plug 220-240Vac
35	56002140	2	#8 Flat Washer
36	56002534	2	#8-32 x 1/4 HP-5 Screw
37	56014033	1	Decal, Warning 220-240Vac
38	56014326	1	Decal, Important
*	56262535	1	Belt Clip 220-240Vac
*	56342319	1	Clamp 220-240Vac (for 56262535)

* = Not Shown

FORM NO. 56042186

100 Volt / 120 Volt

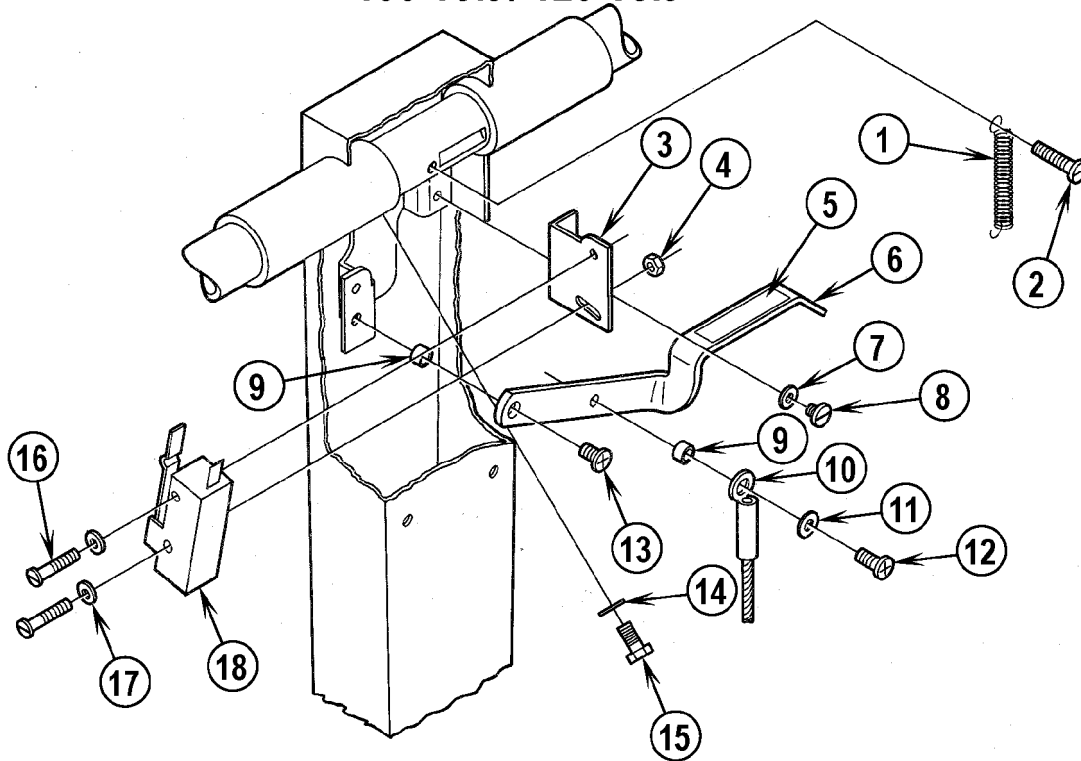

230 Volt

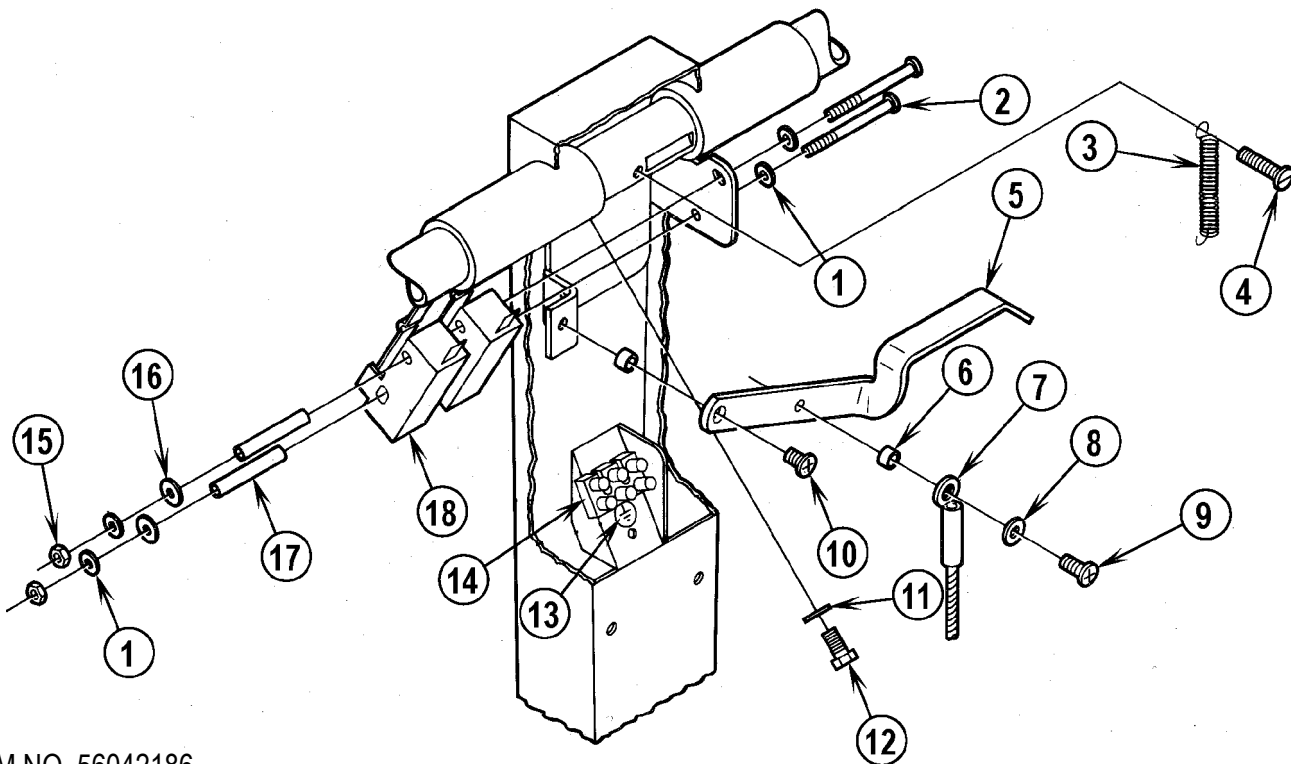

HANDLE ASSEMBLY-REAR VIEW

07-5

Whirlamatic™ UHS20**5**

Item	Ref. No.	Qty	Description
100V / 115V			
1	56445177	1	Spring
2	56002591	1	#8-32 X 7/8 Screw
3	56171209	1	Bracket
4	56001986	1	#4-40 Nut
5	56014856	1	Decal, Handle
6	56171126	1	Lever
7	56002140	5	#8 Washer
8	56002534	5	#8-32 X 1/4 Screw
9	56151092	2	Spacer
10	56171373	1	Cable
11	56009125	1	Washer
12	56002508	1	#10-24 X 1/2 Screw
13	56002518	1	#10-24 X 3/8 Screw
14	56001905	1	5/16 Shakeproof Washer
15	56234079	1	1/4-20 X 1/2 Screw
16	56002183	2	#4-40 X 7/8 Screw
17	56001952	2	#4 Shakeproof Washer
18	56172088	1	Switch
*	56321737	1	Wire Nut
*	56478246	1	Cable Tie

* = Not Shown

Item	Ref. No.	Qty	Description
230V			
1	56001952	4	#4 Shakeproof Washer
2	56002722	2	#4-40 X 1 3/4 Screw
3	56445177	1	Spring
4	56002591	1	#8-32 X 7/8 Screw
5	56171126	1	Lever
6	56151092	2	Spacer
7	56171373	1	Cable
8	56009125	1	Washer
9	56002508	2	#10-24 X 1/2 Screw
10	56002518	1	#10-24 X 3/8 Screw
11	56001905	1	5/16 Shakeproof Washer
12	56234079	1	1/4-20 X 1/2 Screw
13	56014119	1	Decal, Ground Symbol
14	56183523	1	Terminal Block
*	56002712	2	#4-40 X 5/8 Screw
15	56001986	2	#4-40 Nut
16	56200190	2	Fiber Washer
17	56183589	2	Sleeve
18	56172088	2	Switch
*	56325219	3	Cable Tie

* = Not Shown

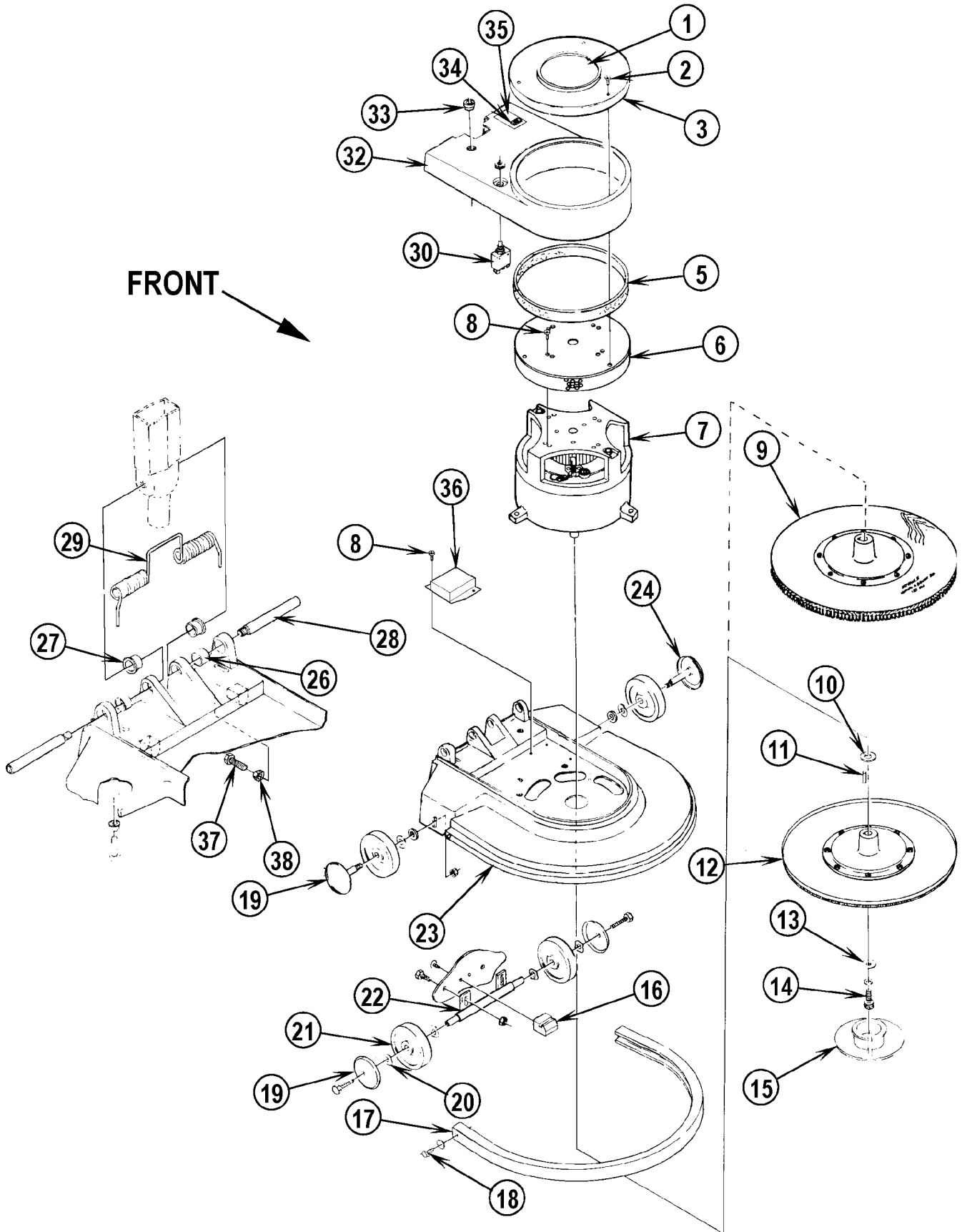

BASE ASSEMBLY

00-3

Whirlamatic™ UHS20

7

Item	Ref. No.	Qty	Description
1	56016474	1	Decal, Whirlamatic 20UHS
2	56372929	3	Screw #10-24
3	56183138	1	Cover Shroud
4			Intentionally Omitted
5	56180032	1	Filter
6	56183571	1	Screen Weldment
7	56183575	1	Motor 100, 115Vac TSB 631, G-1
	56185045	1	Motor 220-240Vac
*			Parts for above Motors
*	56183577	1	Armature (w/bearings)
*	56183581	1	Carbon Brush (set of 4)
*	56183580	1	Carbon Brush Springs (Set)
*	56180163	1	Rectifier
*	56378380	1	Top Bearing
*	56372773	1	Bottom Bearing
*	56183578	1	Commutator Bracket
*	56183579	1	Brush Board Assly (includes Brushes, Springs)
8	56002508	7	#10-24 x 1/2 HP-5 Screw
*	56002011	7	#10 SHPF Washer
9	56505551	1	Burnishing Brush TSB-528, G-10
10	56367192	1	Washer
11	56158135	1	Key
12	56388254	1	Pad Holder Assy TSB-528, G-10
13	56180200	1	Washer
14	56752093	1	Screw 5/16-18 x 1
15	56182058	1	Retaining Ring
16	56183518	1	Handle Catch
17	56183544	1	Bumper
18	56180087	2	Screw
19	56183123	4	Wheel Cover
20	56155381	6	Spring Washer
21	56183552	4	Wheel
22	56183553	1	Axle
23	56183722	1	Skirt Housing
24	56183593	2	Axle TSB 404, G-13
25			Intentionally Omitted
26	56367168	2	Bearing Sleeve
27	56391113	2	Bearing Flange
28	56183522	2	Pivot Pin
29	56183521	1	Torsion Spring
30	56171535	1	17A Circuit Breaker (115Vac Canada only)
	56387316	1	10A Circuit Breaker 220-240Vac
31			Intentionally Omitted
32	56183724	1	Shroud, Motor
33	56185504	1	Strain Relief
34	56249527	1	Indicator Light 100, 115Vac
	56755578	1	Indicator Light 220-240Vac
35	56015104	1	Decal, Brush Wear Light
36	56185432	1	Modified R.F.I. Filter 220-240Vac
37	56002093	2	1/4-20 x 1 Screw
38	56002040	2	1/4-20 Jam Nut
*	56015101	1	Decal, Wiring Diagram 100Vac
*	56014004	1	Decal, Wiring Diagram 115Vac
*	56015622	1	Decal, Wiring Diagram 220-240Vac

* = Not Shown

100V / 115V

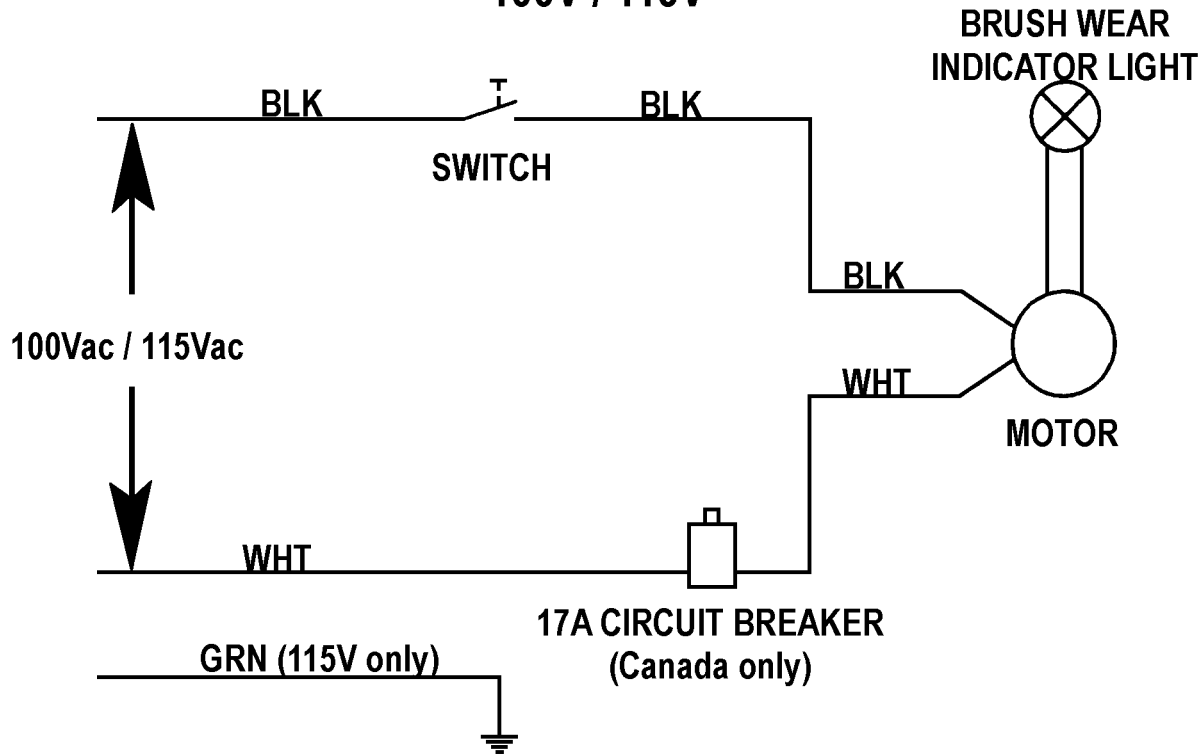

220-240Vac

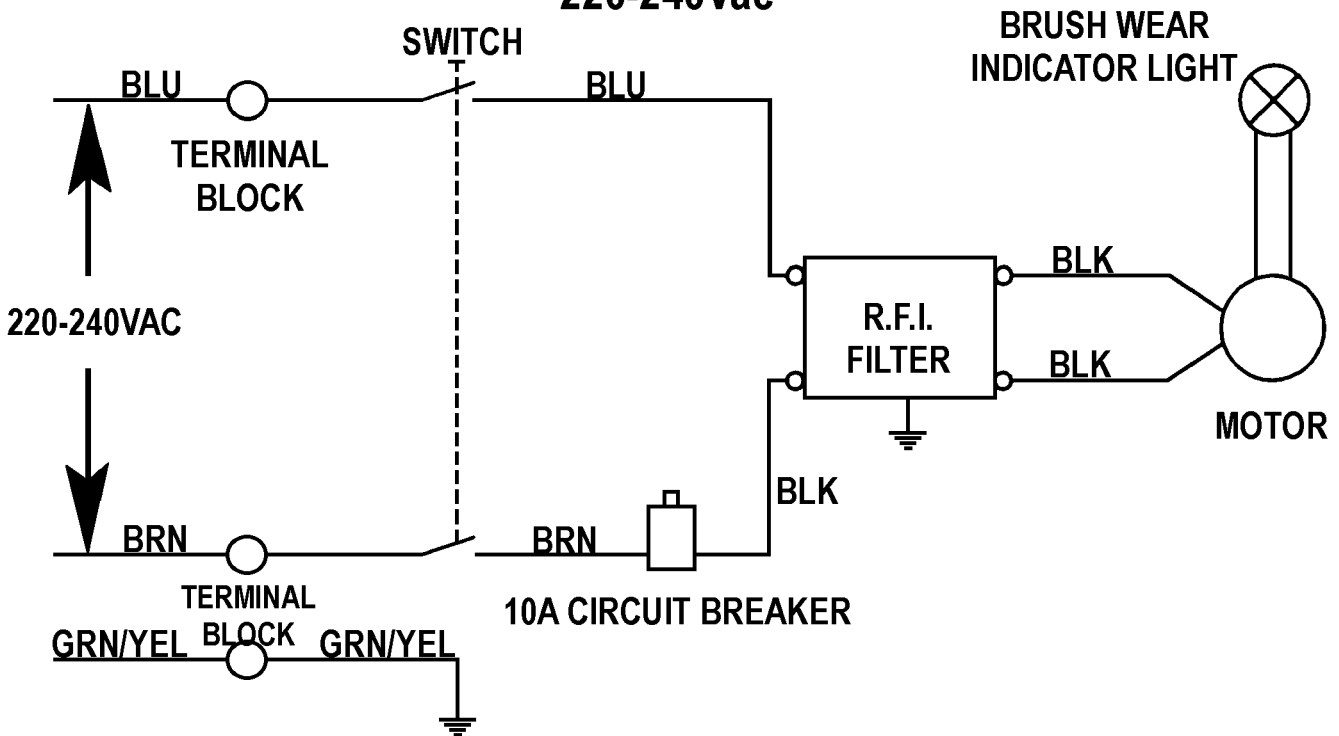

WIRING DIAGRAMS

07-5

Whirlamatic™ UHS20**9**

Item	Ref. No.	Qty	Description
			100V / 115V WIRING DIAGRAM
	56172088	1	Switch
	56249527	1	Brush Wear Indicator Light
	56183575	1	Motor 100, 115Vac
*			Parts for above Motor
*	56183577	1	Armature (w/bearings)
*	56183581	1	Carbon Brush (set of 4)
*	56183580	1	Carbon Brush Springs (Set)
*	56180163	1	Rectifier
*	56378380	1	Top Bearing
*	56372773	1	Bottom Bearing
*	56183578	1	Commutator Bracket
*	56183579	1	Brush Board Assly (includes Brushes, Springs)
	56171535	1	17A Circuit Breaker (Canada only)

* = Not Shown

Item	Ref. No.	Qty	Description
			230V WIRING DIAGRAM
	56183523	1	Terminal Block
	56172088	2	Switch
	56755578	1	Brush Wear Indicator Light
	56185045	1	Motor 220-240Vac
*			Parts for above Motor
*	56183577	1	Armature (w/bearings)
*	56183581	1	Carbon Brush (set of 4)
*	56183580	1	Carbon Brush Springs (Set)
*	56180163	1	Rectifier
*	56378380	1	Top Bearing
*	56372773	1	Bottom Bearing
*	56183578	1	Commutator Bracket
*	56183579	1	Brush Board Assly (includes Brushes, Springs)
	56185432	1	Modified R.F.I. Filter
	56387316	1	10A Circuit Breaker

* = Not Shown



**Nilfisk
Advance**

setting standards

Nilfisk-Advance, Inc.
14600 21st Avenue North
Plymouth, MN 55447-3408
www.nilfisk-advance.com
Phone: 800-989-2235
Fax: 800-989-6566
©2007 Nilfisk-Advance, Inc.