

**Spare parts list**  
**(5.971-014.0) Spare parts list Saber Blade 12**

## Table of contents

---

<b>Spare parts list Saber Blade 12 (5.971-014.0)</b> .....	<b>3</b>
10 Housing (0.105-891.0).....	4
20 Tank (0.105-892.0).....	7
30 Turbine (0.105-893.0).....	9
40 Brush-head (0.105-894.0).....	11
50 Add-on kit carpet cleaning (0.110-087.0).....	15

**Spare parts list Saber Blade 12 (5.971-014.0)**

---

Pos	Material #	Name
10	0.105-891.0	Housing
20	0.105-892.0	Tank
30	0.105-893.0	Turbine
40	0.105-894.0	Brush-head
50	0.110-087.0	Add-on kit carpet cleaning

---

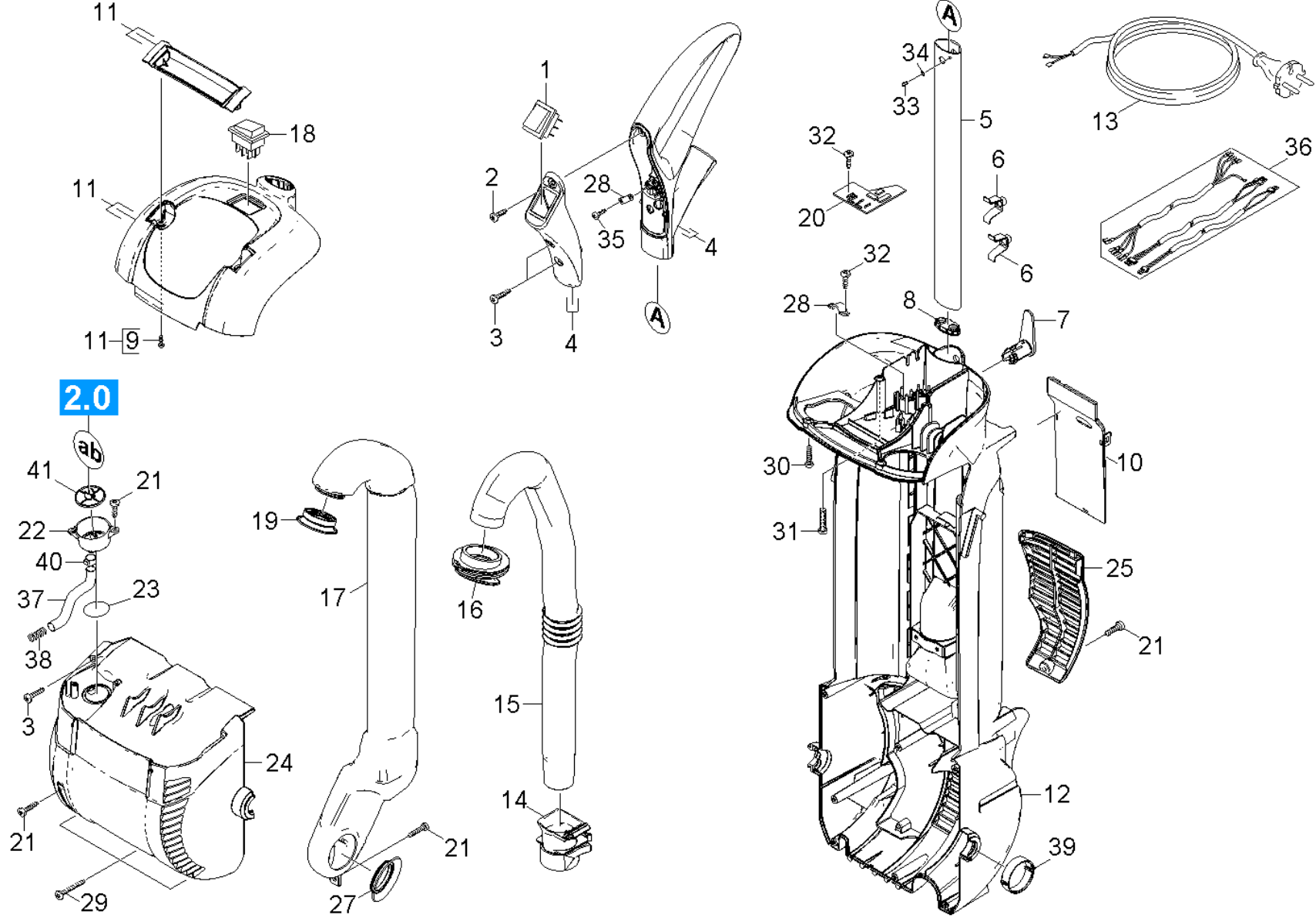

**10 Housing (0.105-891.0)**

ET/VT (spare/wear parts)	Pos	Material #	Name	Qty.	Unit	var. information
X	1	6.630-434.0	Switch two-pole	1.000	ST	
X-X	2	7.303-212.0	Screw 5x20 -A2-70 (In6Rd)	8.000	ST	
	3	7.303-118.0	Screw 5x40 -A2-70 (IN6Rd)	2.000	ST	
	4	4.033-170.0	Handhold complete replacement	1.000	ST	
	5	5.033-228.0	Handle Alu	1.000	ST	
	6	5.033-195.0	Spring handle	2.000	ST	
X	7	5.033-494.0	Catch for cable grey	1.000	ST	
	8	5.033-196.0	Plug handle	1.000	ST	
X-X	9	7.303-107.0	Screw 5x16 -10.9-P2R (K-In6Rd)	2.000	ST	
	10	5.033-175.0	Covering cap cable	1.000	ST	
	11	4.033-162.0	Covering cap housing replacement	1.000	ST	
	12	5.033-172.0	Housing	1.000	ST	
	13	6.649-600.0	Power cable 10m *USA	1.000	ST	*US
	14	5.033-496.0	Sleeve suction tube grey	1.000	ST	
	15	5.033-179.0	Suction pipe tank	1.000	ST	
	16	5.363-688.0	Sealing lip SWT-SL-SB	1.000	ST	
	17	5.033-178.0	Suction pipe turbine	1.000	ST	
X-X	18	6.630-385.0	Switch	1.000	ST	
	19	5.363-687.0	Sealing lip SWT-SL-T	1.000	ST	
	20	6.682-974.0	Distribution circuit board BR 30/4 C	1.000	ST	
X-X	21	7.303-104.0	Screw 5x16 -A2-70 (IN6RD)	3.000	ST	
	22	5.033-190.0	Funnel valve	1.000	ST	
	23	6.362-604.0	O-Ring seal 27,0 X 3,0	1.000	ST	
	24	5.033-173.0	Motor housing	1.000	ST	
	25	5.033-174.0	Flap ventilation	1.000	ST	

## 10 Housing (0.105-891.0)

ET/VT (spare/wear parts)	Pos	Material #	Name	Qty.	Unit	var. information
	27	5.363-689.0	Sealing lip vac motor SL	1.000	ST	
	28	6.373-319.0	Cable clamp R 8	2.000	ST	
X	29	7.303-268.0	Screw 5x30 -A2-70 (In6Rd)	3.000	ST	
X-X	30	7.303-086.0	Screw 5x30 -10.9-R2R (K-In6Rd)	2.000	ST	
	31	6.303-294.0	Screw 5x65-10.9-A2K (Kombi-IN6RD)	2.000	ST	
	32	7.303-095.0	Screw 4x 12-ST-10.9-R2R (IN6RD)	4.000	ST	
X	33	7.303-030.0	Screw M4x8 -St-P2R (In6Rd)	1.000	ST	
	34	7.312-230.0	Serrated lock washer A4,3-FSt-A3E DIN67	1.000	ST	
X-X	35	7.303-102.0	Screw 3,5x12 -A2-70-bk (In6Rd)	2.000	ST	
	36	4.822-540.0	Cable harness BR 30/4 C	1.000	ST	
	37	5.441-074.0	Piece of tube DN6 350mm	1.000	ST	
	38	5.332-973.0	Spring 0,7x5,2x300	1.000	ST	
	39	4.250-079.0	BEARING SHELL kpl.	1.000	ST	
X	40	6.388-701.0	Hose clip with insert 13,3	1.000	ST	
X-X	41	5.033-274.0	Strainer insert funnel	1.000	ST	

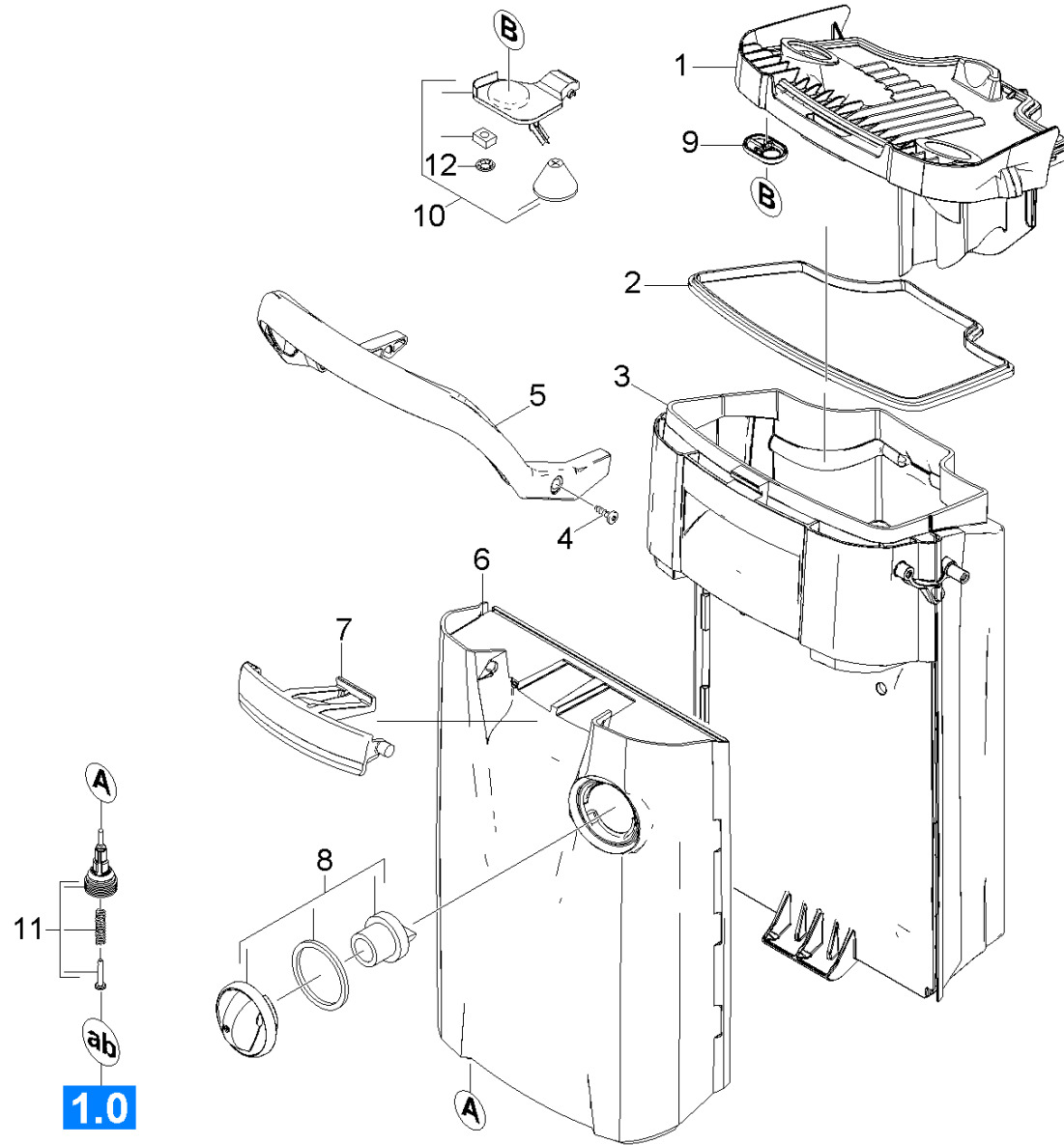

**20 Tank (0.105-892.0)**

ET/VT (spare/wear parts)	Pos	Material #	Name	Qty.	Unit
	1	5.033-181.0	Cover waste water tank	1.000	ST
	2	5.363-711.0	Seal cover tank SW	1.000	ST
	3	5.033-491.0	Waste water tank blue	1.000	ST
X-X	4	7.303-107.0	Screw 5x16 -10.9-P2R (K-In6Rd)	2.000	ST
	5	5.033-183.0	Carrier handle tank	1.000	ST
	6	4.033-492.0	Fresh water tank blue replacement	1.000	ST
	7	5.033-186.0	Notch fresh water tank	1.000	ST
X-X	8	4.033-187.0	Fuel tank filler cap replacement	1.000	ST
	9	5.363-702.0	Seal float	1.000	ST
X-X	10	4.033-182.0	Float replacement	1.000	ST
X-X	11	4.190-258.0	Valve fresh water tank	1.000	ST
X-X	12	6.343-149.0	Quick-fastener	1.000	ST



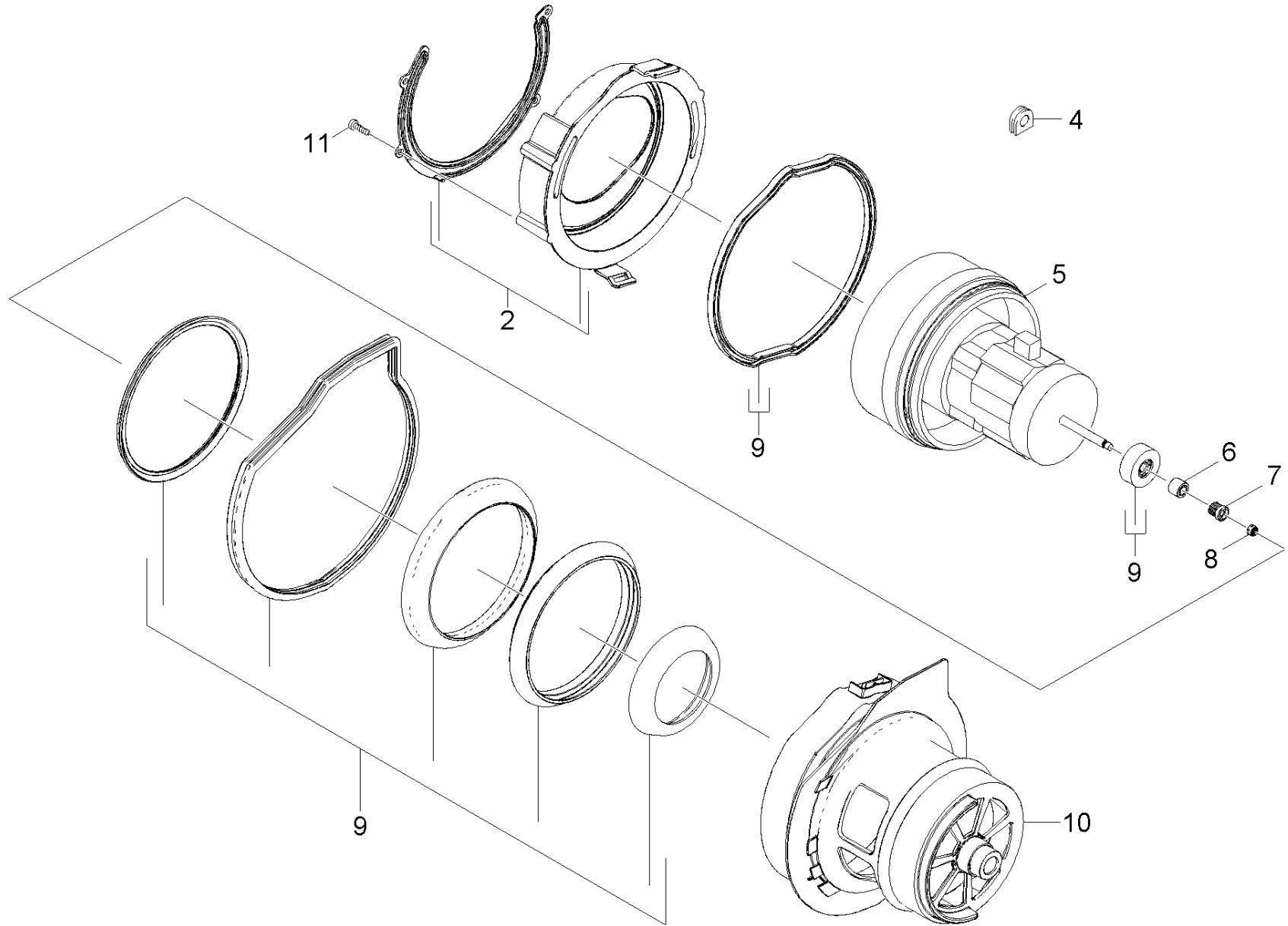

**30 Turbine (0.105-893.0)**

ET/VT (spare/wear parts)	Pos	Material #	Name	Qty.	Unit
	2	4.033-176.0	Cover enclosure replacement	1.000	ST
	4	6.648-064.0	Cable bushing	1.000	ST
X	5	4.490-243.0	Turbine set USA	1.000	ST
	6	5.033-194.0	Flanged pulley pinion	1.000	ST
X	7	5.033-263.0	Motor pinion z13 M3	1.000	ST
	8	7.311-065.0	Hexagon nut M 5-A2-70 ISO 4032	1.000	ST
	9	4.363-690.0	Set of gaskets	1.000	ST
	10	5.033-176.0	Enclosure motor	1.000	ST
X-X	11	7.303-104.0	Screw 5x16 -A2-70 (IN6RD)	4.000	ST

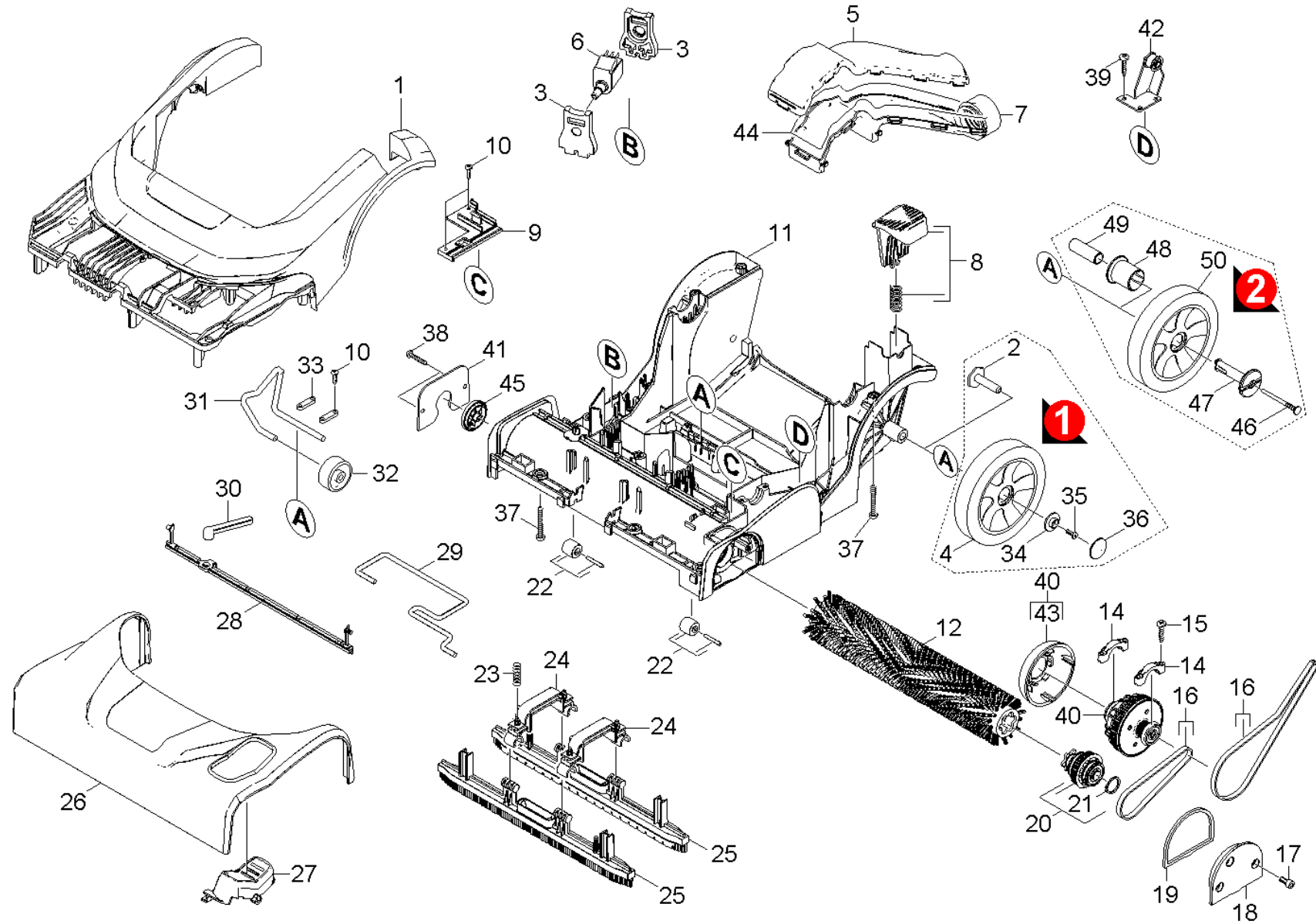

#### 40 Brush-head (0.105-894.0)

ET/VT (spare/wear parts)	Pos	Material #	Name	Qty.	Unit	Footnote text
	1	5.033-486.0	Covering cap brush-head blue	1.000	ST	
	2	5.033-208.0	Snap-fit wheel	2.000	ST	VERSION 1
	3	5.363-694.0	rubber pump	2.000	ST	
	4	5.515-342.0	Wheel black D121	2.000	ST	VERSION 1
	5	5.033-258.0	Suction channel top part	1.000	ST	
	6	6.473-535.0	Pump	1.000	ST	
	7	5.033-207.0	Suction channel brush-head	1.000	ST	
X-X	8	4.481-000.0	Foot pedal complete only for replacement	1.000	ST	
	9	5.033-238.0	Covering cap plate switch	1.000	ST	
	10	7.303-026.0	Screw 4x16 -A2-70 (In6Rd)	6.000	ST	
	11	5.033-200.0	Housing brush-head	1.000	ST	
X-X	12	4.762-428.0	Roller brush complete BR 30/4 C	1.000	ST	
X-X	12	4.762-452.0	Roller brush complete white	1.000	ST	
X-X	12	4.762-453.0	Roller microfibre complete	1.000	ST	
	14	5.033-222.0	Coupler clamp block	2.000	ST	
	15	7.303-096.0	Screw 4x22 -ST-10.9-R2R (IN6RD)	4.000	ST	
X-X	16	4.348-450.0	Toothed belt set	1.000	ST	
X-X	17	7.303-212.0	Screw 5x20 -A2-70 (In6Rd)	3.000	ST	
	18	5.033-223.0	cover retainer transmission	1.000	ST	
	19	5.363-713.0	Seal Lagerdeckel	1.000	ST	
X-X	20	3.763-098.0	Assembly group brushes drive	1.000	ST	
X-X	21	7.343-001.0	Locking ring 10x1-Rf-St DIN 471	1.000	ST	
	22	4.880-058.0	Roller set	2.000	ST	
X-X	23	5.332-952.0	Spring	4.000	ST	
	24	5.033-224.0	Web suction bar	2.000	ST	

**40 Brush-head (0.105-894.0)**

ET/VT (spare/wear parts)	Pos	Material #	Name	Qty.	Unit	Footnote text
X-X	25	4.777-320.0	Suction bar complete 300	2.000	ST	
X-X	25	4.777-324.0	Suction bar complete oil resistant 300	2.000	ST	
	26	4.033-202.0	Bumper replacement	1.000	ST	
	27	5.033-493.0	Pedal suction bar grey	1.000	ST	
X-X	28	5.190-255.0	Strip water distributor	1.000	ST	
	29	5.034-803.0	Retaining bracket suction bar	1.000	ST	
	30	5.363-698.0	Hose nozzle	1.000	ST	
	31	5.034-826.0	Retaining bracket height adjustment	1.000	ST	
X	32	5.515-069.0	Wheel	1.000	ST	
	33	6.647-513.0	Strain relief	2.000	ZST	
X	34	5.100-591.0	Washer wheel	2.000	ST	VERSION 1
X	35	7.306-181.0	Screw M 5x 12-A2-70 (In6Rd)	2.000	ST	VERSION 1
X-X	36	6.343-224.0	Quick-fastener	2.000	ST	VERSION 1
X	37	7.303-268.0	Screw 5x30 -A2-70 (In6Rd)	12.000	ST	
	38	7.303-269.0	Countersunk screw 4x20 -A2-70 (In6Rd)	2.000	ST	
X-X	39	7.303-104.0	Screw 5x16 -A2-70 (IN6RD)	3.000	ST	
X	40	4.470-043.0	Coupler complete	1.000	ST	
	41	5.009-415.0	Bracket brush	1.000	ST	
	42	4.470-040.0	Pressure roller complete	1.000	ST	
X	43	5.033-269.0	Cap coupler	1.000	ST	
	44	6.273-037.0	Seal string cellular rubber 3	1.000	M	TO ORDER AS CUT GOODS
X	45	5.033-230.0	Thread deflector	1.000	ST	
	46	5.033-279.0	Pin snap-fit wheel	2.000	ST	VERSION 2
	47	5.033-208.0	Snap-fit wheel	2.000	ST	VERSION 2
	48	5.033-264.0	Plain bearing with collar	2.000	ST	VERSION 2

**40 Brush-head (0.105-894.0)**

---

ET/VT (spare/wear parts)	Pos	Material #	Name	Qty.	Unit	Footnote text
	49	5.112-863.0	Bush	2.000	ST	VERSION 2
	50	5.515-338.0	Wheel D121	2.000	ST	VERSION 2

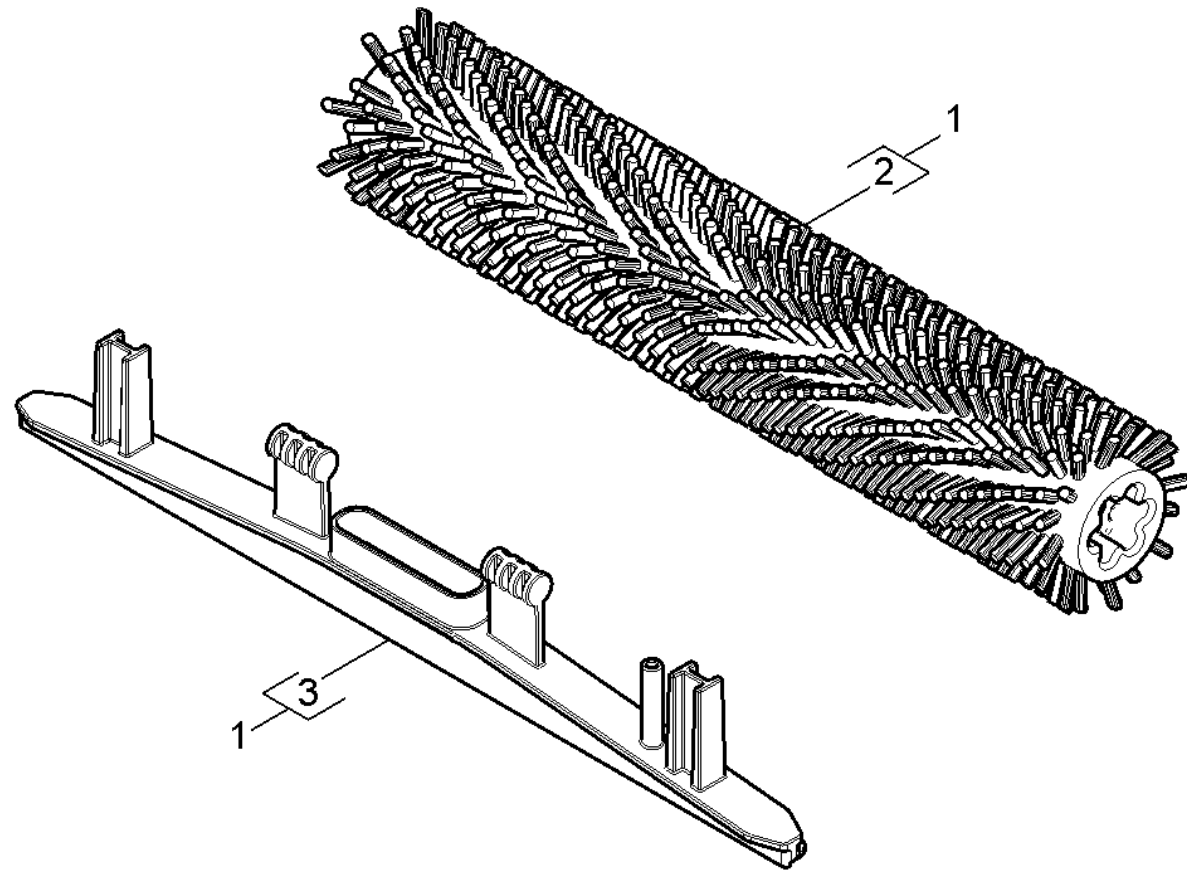

**50 Add-on kit carpet cleaning (0.110-087.0)**

---

ET/VT (spare/wear parts)	Pos	Material #	Name	Qty.	Unit
X-X	1	2.783-005.0	Add-on kit carpet cleaning BR 30/4 C	1.000	ST
X	2	4.762-499.0	Roller brush blue complete 300	1.000	ST
X	3	5.033-275.0	Suction bar carpet cleaning	1.000	ST