



# GS170

## Forklift/Loader Sweeper



33 Gallon Gravity Water System

67" Sweeping Width

106 Gallon Debris Capacity

Adjustable Fully Floating Main Broom

Heavy Duty Rubber Wheels Castors

Attachable Side Kerb Brush

Optional Power Pack

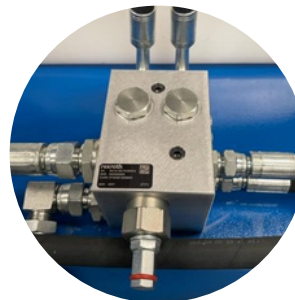
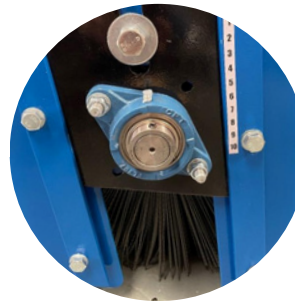

## Hydraulic

Hydraulic Operation with Flow Restrictor

Hydraulic Opening of Debris Container

Hydraulic Closing of Debris Container

Hydraulic Tech Pack ensures the Broom can only Sweep in the Correct Direction

Overall Width	Sweeping Width	Weight	LxWxH (mm)	Flow Rate	Width incl. Side Brush
77"	67"	992 lbs	81 x47" x77"	9 Gal/min	85"

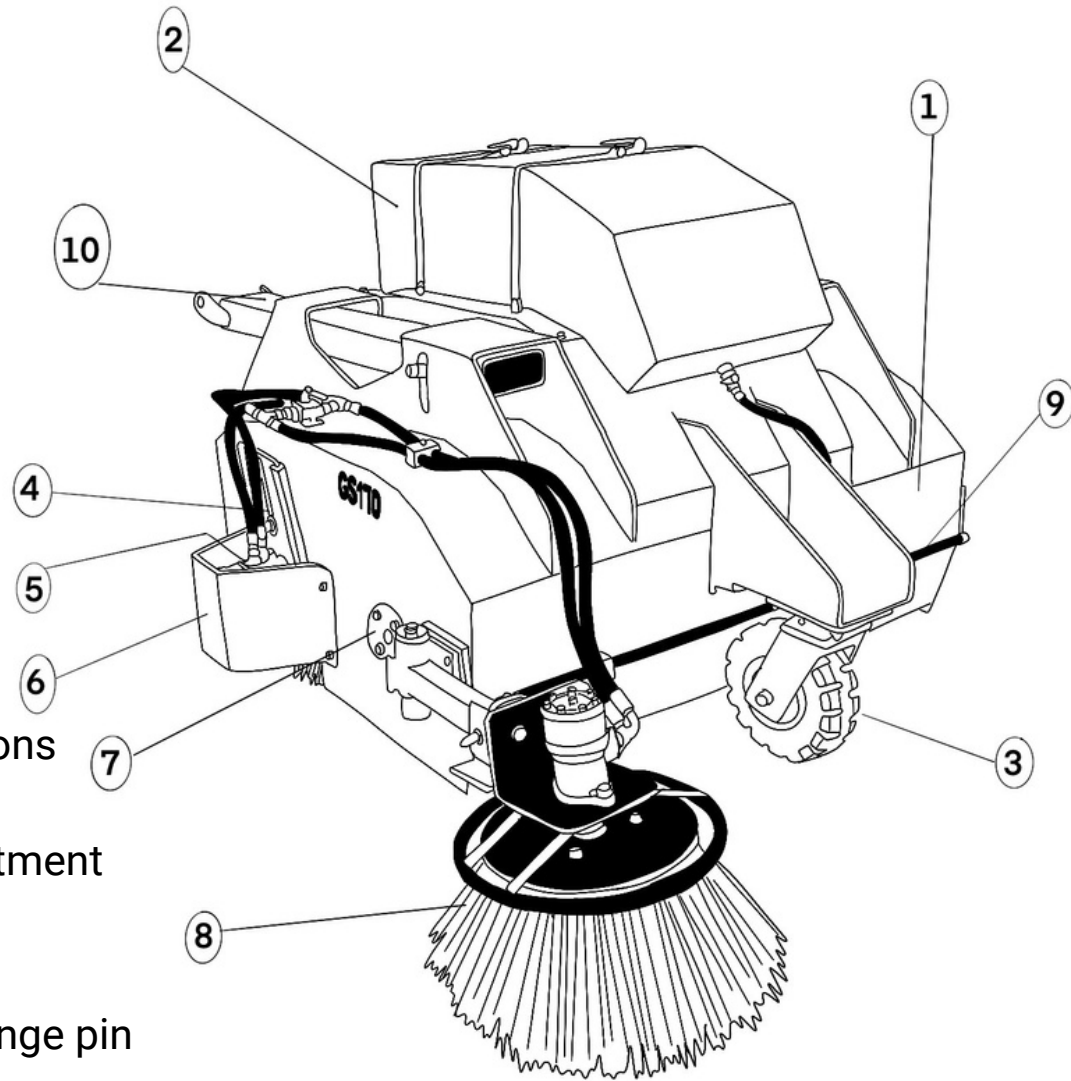

- 1. Main frame
- 2. Water tank 33 Gallons
- 3. Front wheel.
- 4. Brush height adjustment
- 5. Main brush motor
- 6. Motor cover
- 7. Debris container hinge pin
- 8. Side kerb brush
- 9. Gravity water spray bar
- 10. Floating fork pockets with locking pins



Caliber Equipment Inc.  
8433 Erle Rd, Mechanicsville,  
VA 23116, United States

888-550-0945  
+1 804-798-4333

[help@caliberequipment.com](mailto:help@caliberequipment.com)  
[www.caliberequipment.com](http://www.caliberequipment.com)