



GS140

Forklift Sweeper



- 33 Gallon Gravity Water System
- 55" Sweeping Width
- 92 Gallon Debris Capacity
- Adjustable Fully Floating Main Broom
- Heavy Duty Rubber Wheels Castors
- Attachable Side Kerb Brush
- Optional Power Pack

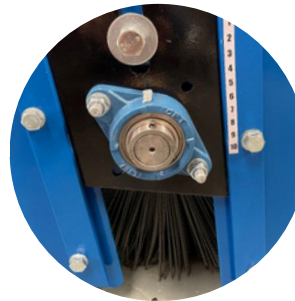

Hydraulic

- Hydraulic Operation with Flow Restrictor
- Hydraulic Opening of Debris Container
- Hydraulic Closing of Debris Container
- Hydraulic Tech Pack ensures the Broom can only Sweep in the Correct Direction

Overall Width	Sweeping Width	Weight	LxWxH (")	Flow Rate	Width incl. Side Brush
65"	55"	838lbs	81 x 47 x 65	9 Gal/min	75"

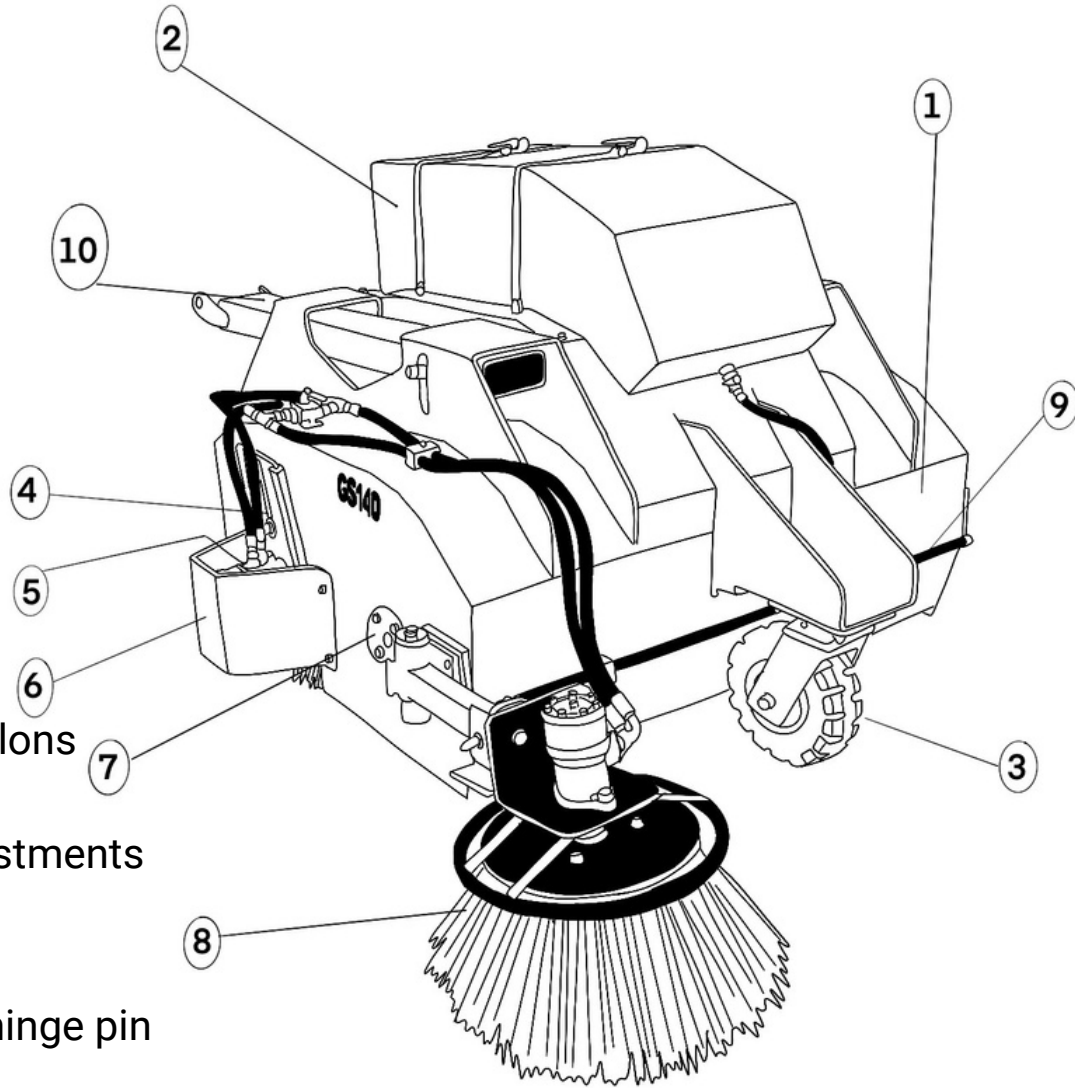

- 1. Main frame
- 2. Water tank 33 Gallons
- 3. Front wheel.
- 4. Brush height adjustments
- 5. Main brush motor
- 6. Motor cover
- 7. Debris container hinge pin
- 8. Side kerb brush
- 9. Gravity water spray bar
- 10. Floating fork pockets with locking pins



Caliber Equipment Inc.
8433 Erle Rd,
Mechanicsville,
VA 23116, United States

888-550-0945
+1 804-798-4333

help@caliberequipment.com
www.caliberequipment.com

