

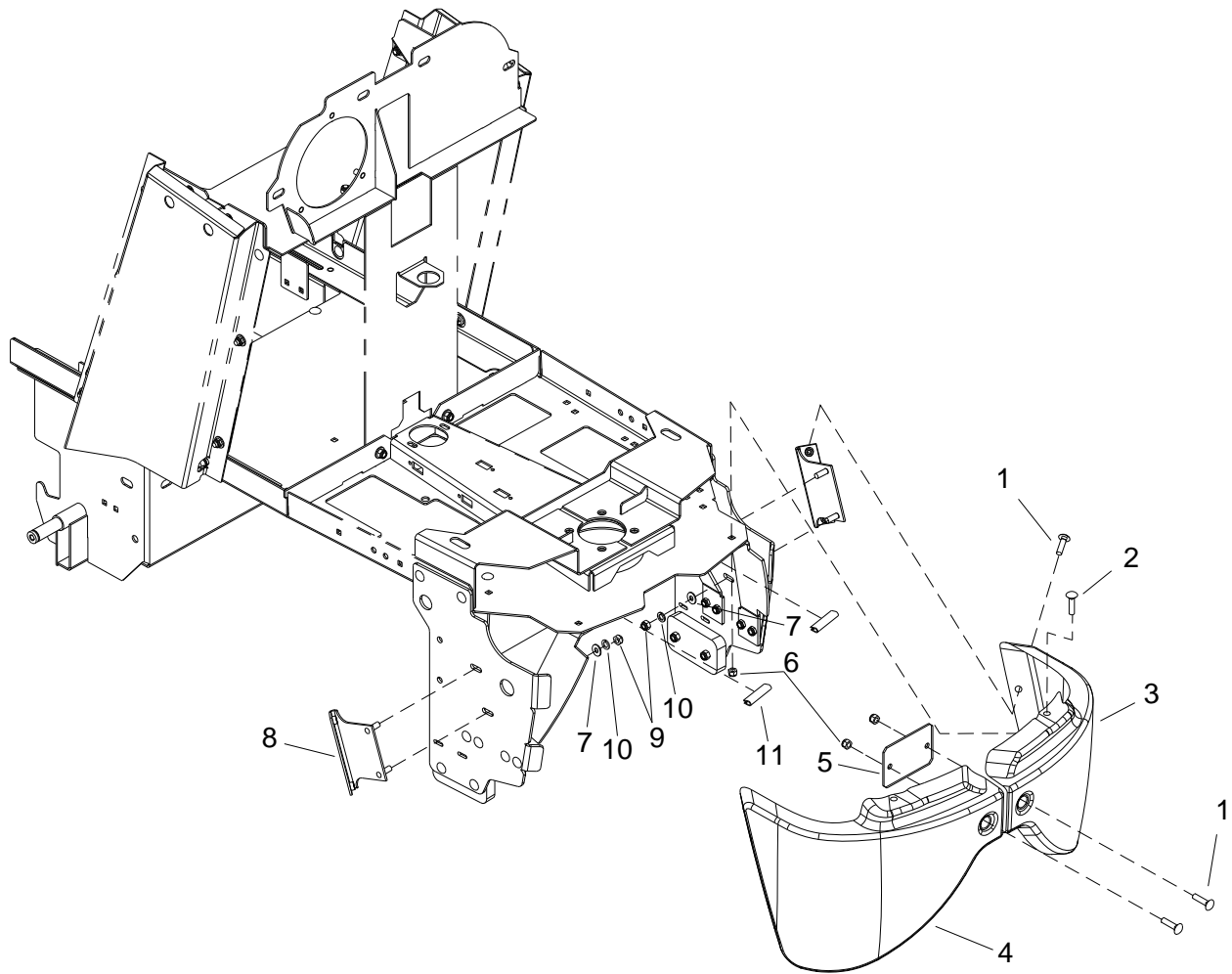

chariot
PARTS

BUMPER



BUMPER

REF	PART NO.	PRV NO.	QTY	DESCRIPTION	SERIAL NO. FROM	NOTES:
1	86276890	70752	6	SCR, 5/16-18X3/4 PTHMS SS		
2	86007070	70849	2	SCR, 5/16-18X1.00 PPHMS SS		
3	86063230	140813	1	BUMPER, LEFT		
4	86063240	140814	1	BUMPER, RIGHT		
5	86071020	140783	1	BRKT, FRONT BUMPER		
6	86270830	57023	4	NUT, 5/16-18 HEX NYLOCK SS		
7	86010670	87029	4	WASHER, 5/16 FLAT SS		
8	86070730	140729	2	BRKT, BUMPER MOUNT, SIDE		
9	86197040	57264	4	NUT, 5/16-18 HEX ACORN PLTD		
10	86279130	87083	4	WASHER, 5/16 SPLIT LOCK PLTD		
11	86251750	67602	2	RISER, BUMPER		

CONTROL PANEL-BASIC-CYLINDRICAL

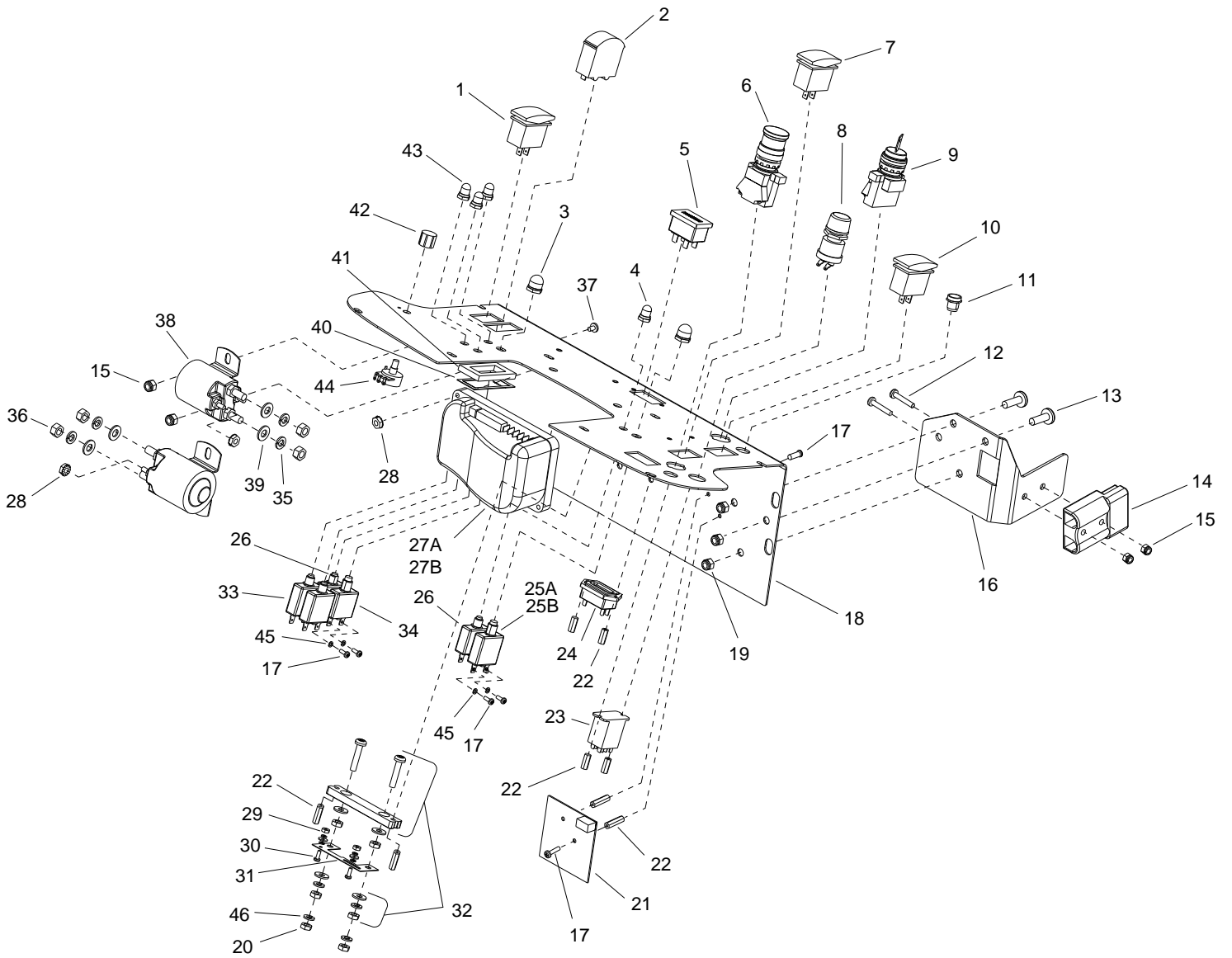

CONTROL PANEL-BASIC-CYLINDRICAL

REF	PART NO.	PRV NO.	QTY	DESCRIPTION	SERIAL NO. FROM	NOTES:
1	86007210	72165	1	SWITCH, DPDT 3-POSITION ROCKER		
2	86246980	54201	1	METER, 0-50 AMP DC		
3	86008900	80845	2	BOOT, SEAL-PUSH BUTTON 7/16-28		
4	86002010	14942	1	BOOT, 3/8 CIRCUIT BREAKER		
5	86005560	54199	1	METER, 36V LED BATTERY		
6	86007180	72160	1	SWITCH, EMERGENCY STOP		
7	86257110	72189	1	SWITCH, 4P3T FIXED POS ROCKER		
8	86257280	81371	1	SWITCH, PUSH BUTTON		
9	86007190	72161	1	SWITCH KEY DPSTN		
10	86007140	72130	1	SWITCH, SPST 2-POSITION ROCKER		
11	86257140	72196	1	SWITCH, RESET PB ROUND		
12	86273820	70019	2	SCR, 1/4-20 X 1.25 HHCS		
13	86277480	70850	3	SCR, 5/16-18 X 1/2 PTHMS SS		
14	86008760	80682	1	CONN, 175 DCA GRY W/O TERMS		
15	86005810	57245	6	NUT, 1/4-20 HEX NYLOCK SS		
16	86070720	140728	1	BRKT, BATT CONN, BASIC		
17	86273990	70067	8	SCR, 6-32 X 3/8 PPHMS		
18	86078150	61475	1	PANEL, BASIC		
19	86271840	57285	3	NUT, 5/16-18 HEX NYLOCK THIN SS		
20	86005710	57105	2	NUT, 1/4-20 HEX W/STAR WASHER		
21	86003250	27944	1	CIRCUIT BOARD, SOL FLOAT WIRED		
22	86255900	73538	8	STANDOFF, 6-32 X 5/8 HEX NYL		
23	86251410	67506	1	RELAY, 15A 36V MINI		
24	86005530	54154	1	METER, 12-48 VDC LED HOUR		
25A	86001910	14606	1	BREAKER, 30A 50VDC CIRCUIT	*(1)	WAS 14607, 25A
25B	86001920	14607	1	BREAKER, 25A 50VDC CIRCUIT	*(16)	CYLINDRICAL ONLY
26	86002000	14717	2	BREAKER, 3 AMP		
27A	86002760	270092	1	CONTROLLER, CHAIN DRIVE BASIC		FOR 29269-DRIVE UNIT (CHAIN)
27B	86027740	27911	1	CONTROLLER, GEAR DRIVE BASIC		FOR 29276- DRIVE UNIT (GEAR)
28	86005700	57104	10	NUT, 10-32 W/STAR WASHER PLTD		
29	86271790	57256	2	NUT, 6-32 HEX BRASS		
30	86276250	70615	2	SCR, 6-32 X 3/8 SRHMS BR		
31	86008190	73988	1	SHUNT, DC AMM. 15 AMP, 50 MV		
32	86229770	140805	1	BLOCK, SHUNT MOUNT		
33	86001730	140804	2	BREAKER, 18A 250VAC, 50VDC		
34	86001910	14606	1	BREAKER, 30A 50VDC CIRCUIT		
35	86279130	87083	4	WASHER, 5/16 SPLIT LOCK PLTD		
36	86271120	57125	4	NUT, 5/16-18 BRASS		
37	86223740	70872	4	SCR, 1/4-20 X .59 PPHMS SS C		
38	86006370	67315	2	RELAY, 36VDC 100AMP HVY DUTY		
39	86010670	87029	4	WASHER, 5/16 FLAT SS		
40	86249290	62283	1	PLATE, METER RETAINING		
41	86237830	35264	1	GASKET, AMP METER		
42	86242110	48088	1	KNOB, .90 OD X .25 COLLET		
43	86002010	14942	3	BOOT, 3/8 CIRCUIT BREAKER		
44	86006310	66335	1	POTENTIOMETER, 50K OHMS		
45	86279300	87134	4	WASHER, #6 LOCK		
46	86010630	87013	2	WASHER, 1/4 ID X 5/8 OD SS		

*SEE SERIAL NUMBER PAGE.

CONTROL PANEL-DELUXE

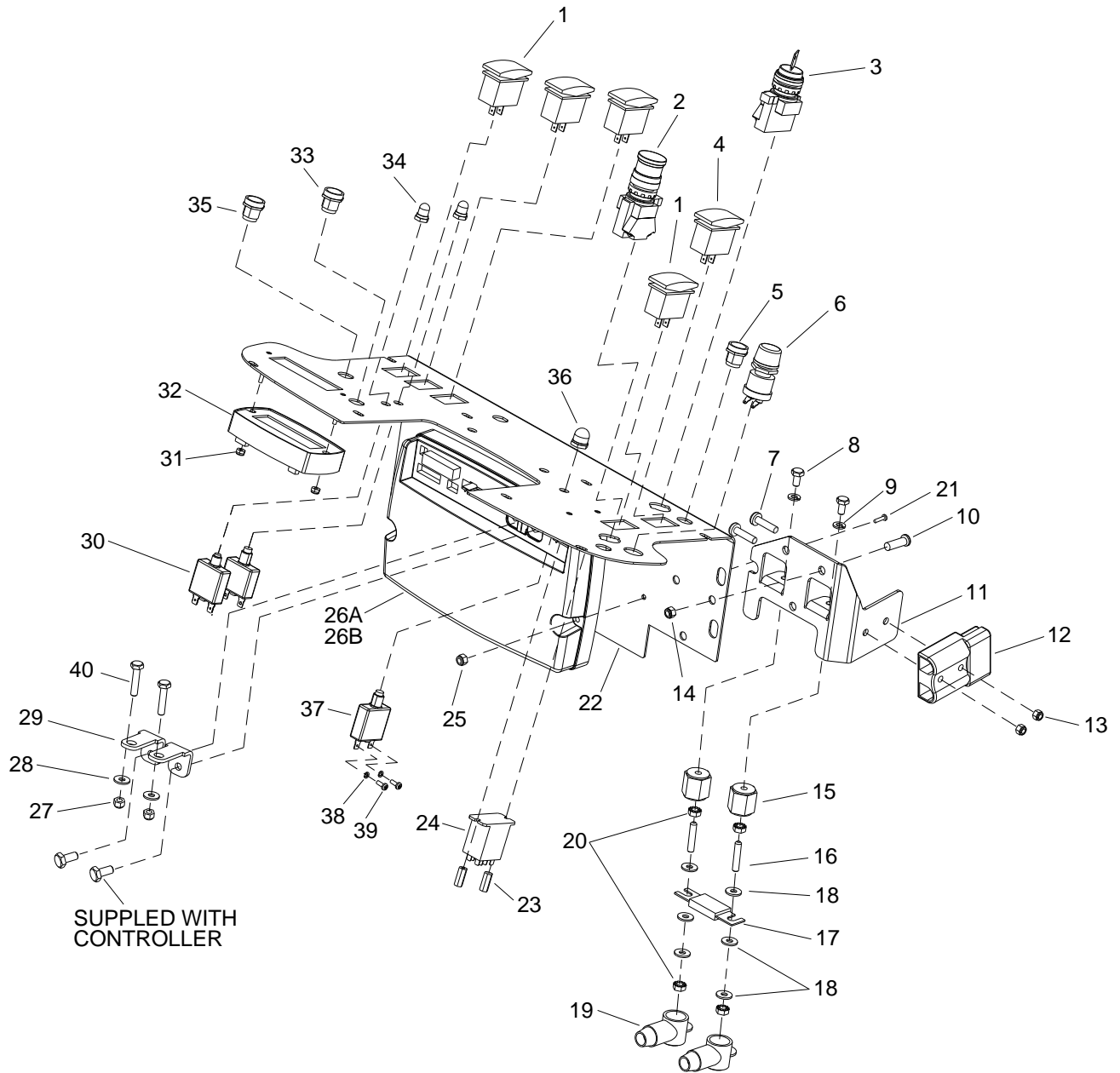

CONTROL PANEL-DELUXE

REF	PART NO.	PRV NO.	QTY	DESCRIPTION	SERIAL NO. FROM	NOTES:
1	86007520	730142	3	SWITCH, SPDT 3-POSITION MOM		
2	86007180	72160	2	SWITCH, EMERGENCY STOP		
3	86007190	72161	1	SWITCH KEY DPST		
4	86007140	72130	1	SWITCH, SPST 2-POSITION ROCKER		
5	86257140	72196	2	SWITCH, RESET PB ROUND		
6	86257280	81371	1	SWITCH, PUSH BUTTON		
7	86273820	70019	2	SCR, 1/4-20 X 1.25 HHCS		
8	86273830	70020	2	SCR, 1/4-20 X 1/2 HHCS SS		
9	86010780	87162	2	WASHER, 1/4 SPLIT LOCK PLTD		
10	86277480	70850	3	SCR, 5/16-18 X 1/2 PTHMS SS		
11	86070670	140722	1	BRKT, BATTERY CONNECTOR		
12	86008760	80682	1	CONN, 175 DCA GRY W/O TERMS		
13	86005810	57245	2	NUT, 1/4-20 HEX NYLOCK SS		
14	86271840	57285	3	NUT, 5/16-18 HEX NYLOCK THIN SS		
15	86255910	73659	2	STANDOFF, 1/4-20 X 1.0 HEX INS		
16	86006850	70393	2	SET SCR, 1/4-20 X 1.25L		
17	86008790	80687	1	FUSE, 125 AMP		
18	86010630	87013	6	WASHER, 1/4 ID X 5/8 OD SS		
19	86008920	80889	2	BOOT, RUBBER TERM. ISOLATOR		
20	86005710	57105	4	NUT, 1/4-20 HEX W/STAR WASHER		
21	86274410	70195	2	SCR, 10-32 X 1.25 PPHMS SS		
22	86078160	61476	1	PANEL, DELUXE		
23	86255900	73538	2	STANDOFF, 6-32 X 5/8 HEX NYL		
24	86251410	67506	1	RELAY, 15A 36V MINI		
25	86270990	57090	2	NUT, 10-32 HEX NYLOCK SS		
26A	86002770	270095	1	CONTROLLER, CHAIN DRIVE DELUXE		FOR 29269 DRIVE UNIT, CHAIN
26B	86292580	-	1	CONTROLLER, GEAR DRIVE DELUXE		FOR 29276 DRIVE UNIT, GEAR
27	86271910	57295	2	NUT, 5/16-18 FLEXLOCK		
28	86010670	87029	2	WASHER, 5/16 FLAT SS		
29	86068850	140219	2	BRKT, CABLE ATTACH		
30	86001730	140804	2	BREAKER, 18A 250VAC, 50VDC		
31	86270920	57049	2	NUT, 6-32 HEX NYLOCK SS		
32	86005570	54200	1	MODULE, LCD DELUXE		
33	86007480	730124	1	SWITCH ASM, SEALED PUSHBUTTON		
34	86002010	14942	2	BOOT, 3/8 CIRCUIT BREAKER		
35	86257130	72195	1	SWITCH, ON -TOUCH PB ROUND		
36	86001260	140218	1	BOOT, DB 3/8-27 UNS 2B	*(11)	WAS 80845
37	86001950	14666	1	BREAKER, 30A W/AUX CONTACT	*(11)	WAS 14606
38	86279300	87134	2	WASHER, #6 LOCK		
39	86273990	70067	2	SCR, 6-32 X 3/8 PPHMS		
40	86275760	70540	2	SCR, 5/16-18 X 1 HHCS GR8 PLTD		

*SEE SERIAL NUMBER PAGE.

CONTROL PANEL HOUSING

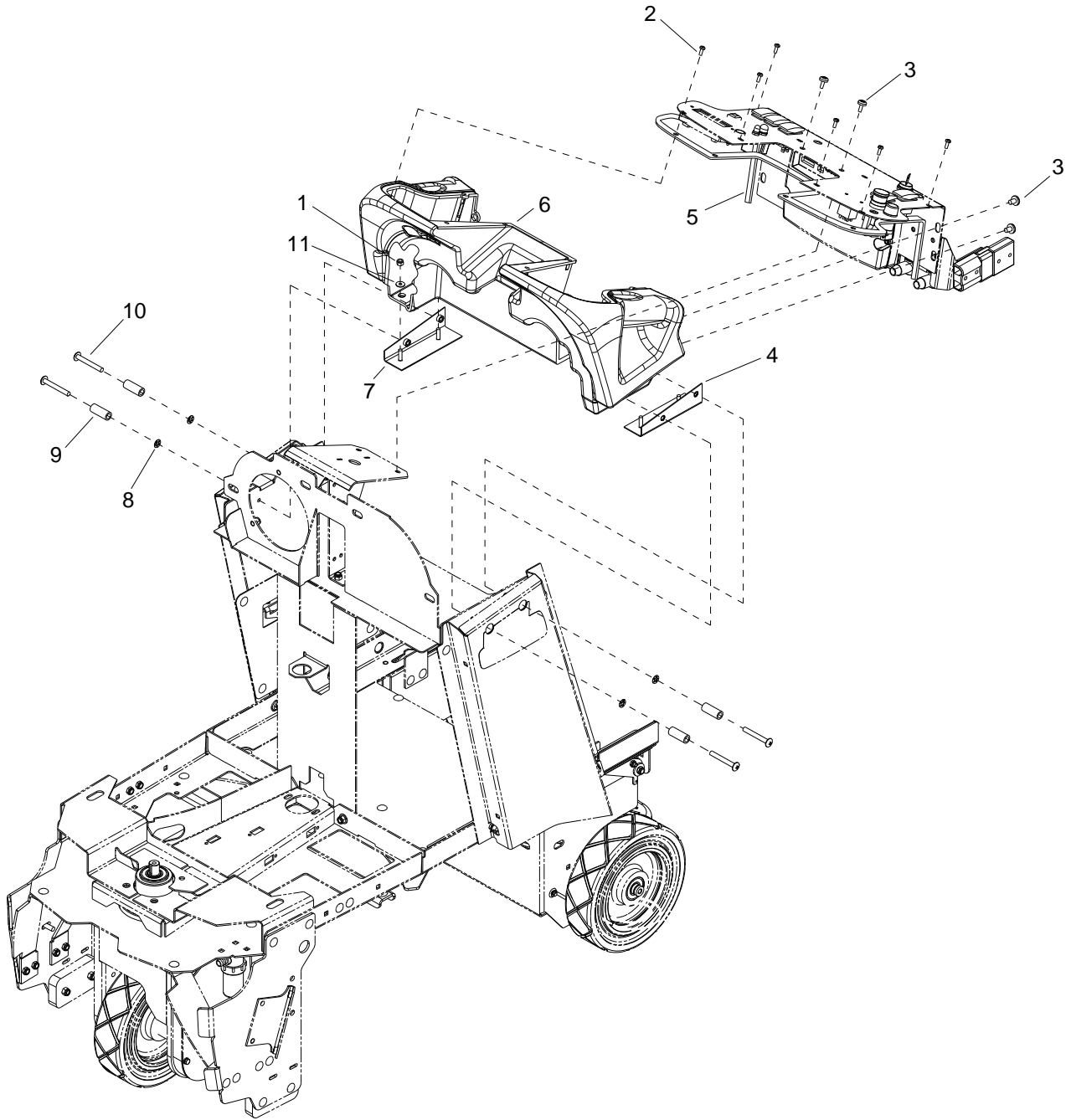

CONTROL PANEL HOUSING

REF	PART NO.	PRV NO.	QTY	DESCRIPTION	SERIAL NO. FROM	NOTES:
1	86005810	57245	4	NUT, 1/4-20 HEX NYLOCK SS		
2	86290540	-	6	SCR, 10-32 X 1/2 TORX SS BLK NP		
3	86277480	70850	6	SCR, 5/16-18 X1/2 PTHMS SS		
4	86070710	140726	1	BRKT, LEFT CONSOLE MOUNT		
5	86237900	35278	3	GASKET, .125 X .25W X 23L		
6	86031730	270084	1	CONSOLE		
7	86070700	140725	1	BRKT, RIHGT CONSOLE MOUNT		
8	86279750	87252	4	WASHER, RET, PUSHNUT, 5/16 BOLT		
9	86089650	78524	4	TUBE, 5/8 OD X .357 ID X 1.57		
10	86277420	70841	4	SCR, 5/16-18 X 2.5 PTHMS SS		
11	86010630	87013	4	WASHER, 1/4 ID X 5/8 OD SS		

DECAL

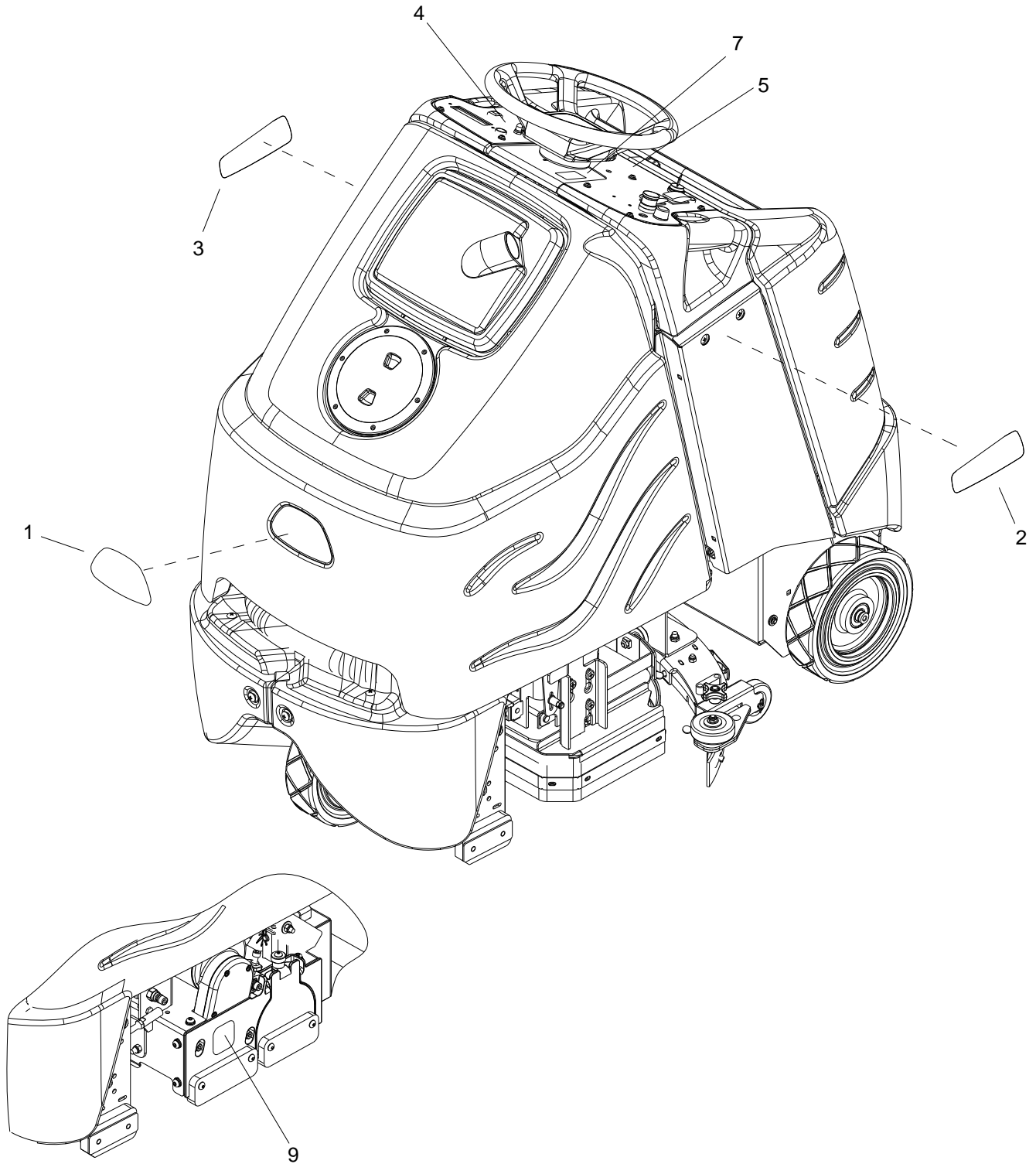

DECAL

REF	PART NO.	PRV NO.	QTY	DESCRIPTION	SERIAL NO. FROM	NOTES:
1	86004970	50990	1	LABEL, WINDSOR LOGO DOMED		
2	86244740	501222	1	DECAL, CHARIOT, ISCRUB RT		WAS 500884
3	86244750	501223	1	DECAL, CHARIOT, ISCRUB LT		WAS 500885
4A	86244200	500883	1	LABEL, PANEL BASIC RIGHT		
4B	86244180	500881	1	LABEL, PANEL DLX RIGHT		
5A	86244190	500882	1	LABEL, PANEL BASIC LEFT		
5B	86244170	500880	1	LABEL, PANEL DLX LEFT		
6	OPEN					
7	86243990	500780	1	LABEL, COVER PANEL		
8	OPEN					
9	86298970	-	1	LABEL, CLEAN BRUSHES AND DECK		CYLINDRICAL ONLY

NOTE: See "SAFETY LABEL LOCATION" page for safety label information.

FRAME-LOWER

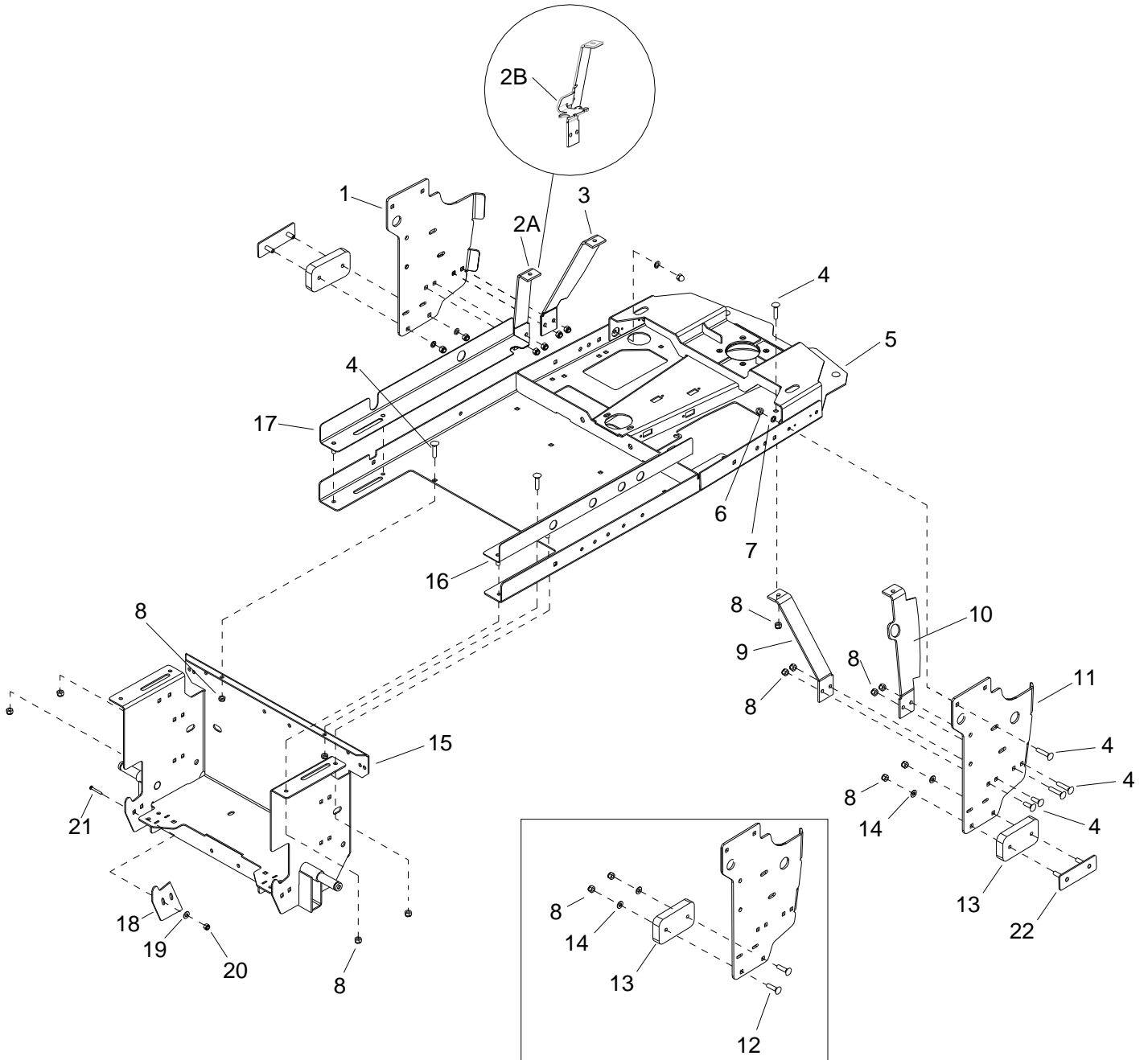

FRAME-LOWER

REF	PART NO.	PRV NO.	QTY	DESCRIPTION	SERIAL NO. FROM	NOTES:
1	86070750	140731	1	BRKT, TIP BAR LEFT		
2A	86071130	140812	1	BRKT, TIP BRACE, LEFT, REAR		CYLINDRICAL ONLY
2B	86303720	-	1	BRKT, BRACE, LT. REAR SOL		DISK ONLY
3	86070760	140733	1	BRKT, TIP BRACE, LEFT		
4	86276070	70593	16	SCR, 5/16-18 X 3/4 CARRIAGE SS		
5	86092500	34428	1	FRAME, MAIN		
6	86197040	57264	4	NUT, 5/16-18 HEX ACORN PLTD		
7	86279130	87083	4	WASHER, 5/16 SPLIT LOCK PLTD		
8	86270830	57023	16	NUT, 5/16-18 HEX NYLOCK SS		
9	86071120	140811	1	BRKT, TIP BRACE, LEFT, REAR		
10	86071430	140863	1	BRKT, BRACE RIGHT FRONT		
11	86070740	140730	1	BRKT, LINKAGE, RIGHT		
12	86277470	70848	4	SCR, 5/16-18 X 1.5 CARRIAGE SS		
13	86064300	140790	2	PAD, TIPPING BAR		
14	86010670	87029	4	WASHER, 5/16 FLAT SS		
15	86091420	05251	1	AXLE, REAR WELDMENT		
16	86088760	75458	1	TRAY, SLIDE, LEFT		
17	86088750	75457	1	TRAY, SLIDE, RIGHT		
18	86079290	620097	2	PLATE, REAR COVER ADJ	*(6)	
19	86010630	87013	4	WASHER, 1/4 ID X 5/8 OD SS	*(6)	
20	86271870	57290	4	NUT, 1/4-20 HEX NYLOCK THIN SS	*(6)	
21	86276950	70772	4	SCR, 1/4-20 X 3/4 CARRIAGE SS	*(6)	
22	86079320	620101	2	PLATE, PAD RETAINER	*(7)	

* SEE SERIAL NUMBER PAGE.

** CALL MANUFACTURER FOR SERIAL NUMBER

FRAME-UPPER

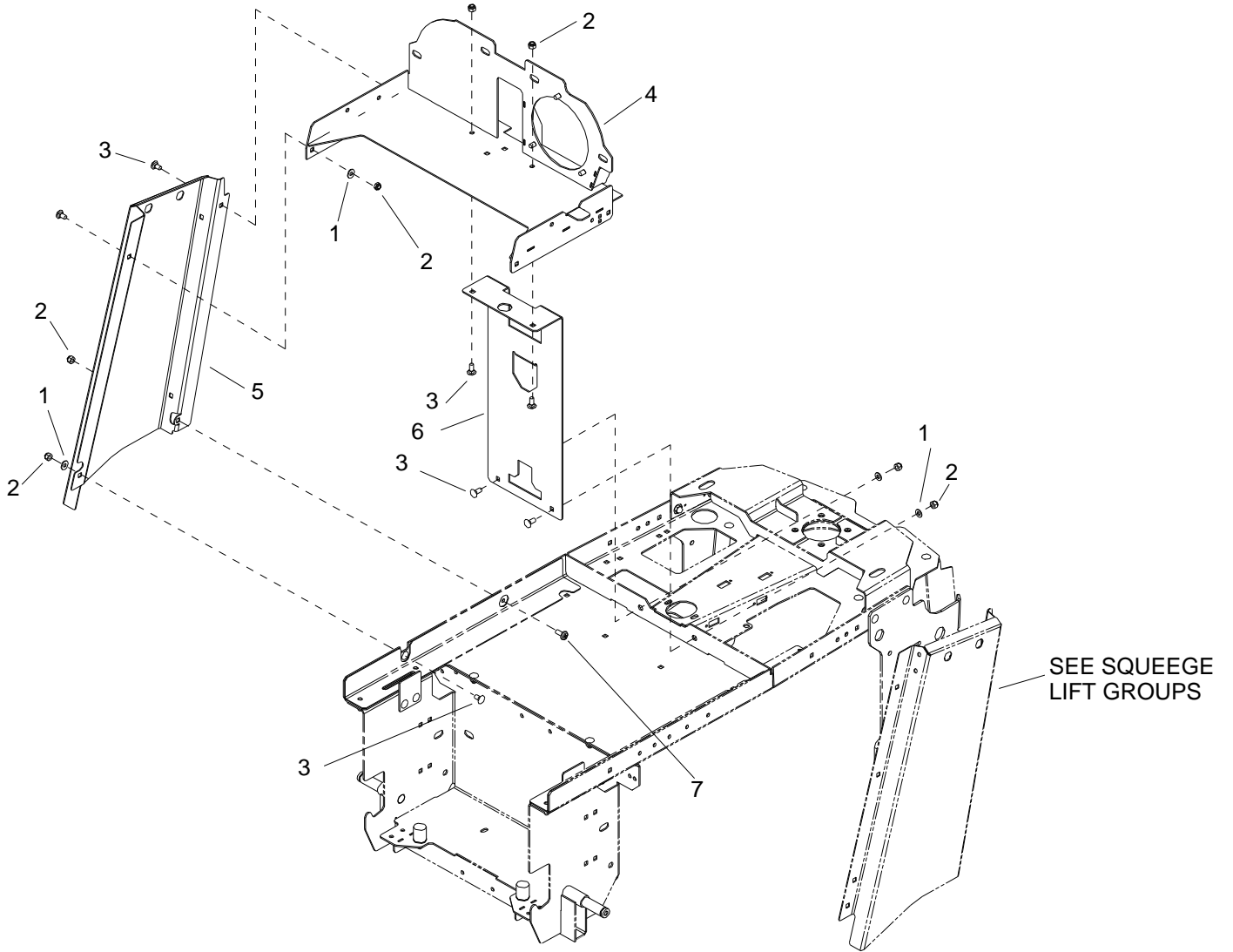

FRAME-UPPER

REF	PART NO.	PRV NO.	QTY	DESCRIPTION	SERIAL NO. FROM	NOTES:
1	86010670	87029	5	WASHER, 5/16 FLAT SS		
2	86270830	57023	8	NUT, 5-16-18 HEX NYLOCK SS		
3	86276070	70593	7	SCR, 5-16-18 X 3/4 CARRIAGE SS		
4	86091750	140727	1	BRKT, HORIZ ELECT		
5	86073500	270090	1	BRKT, SIDE CHANNEL L		
6	86083080	66437	1	PLATE, VERT BEARING SUPPORT		
7	86277460	70847	1	SCR, 5/16-18 X 5/8 BSHCS SS		

PEDAL PLATFORM

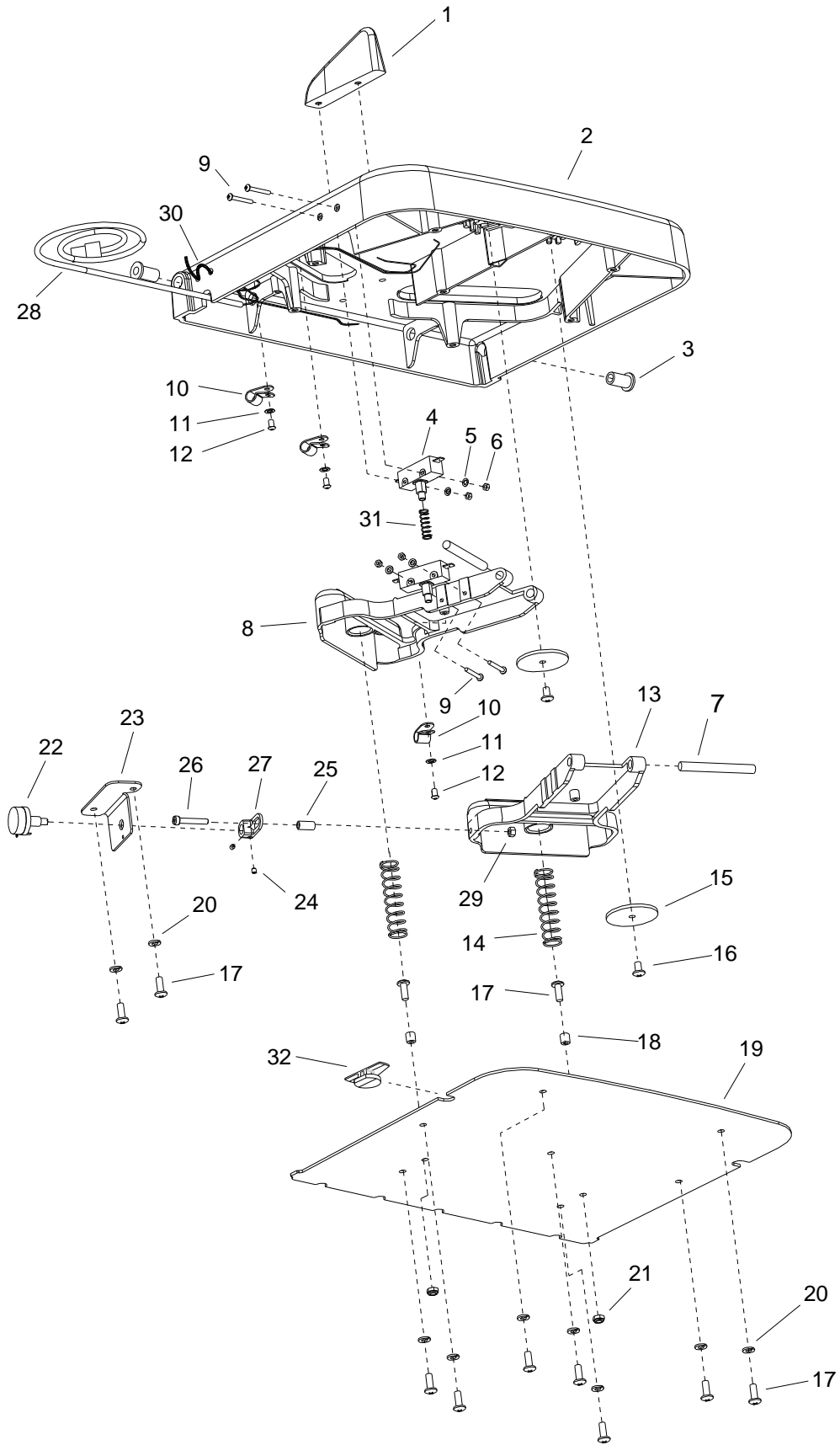

PEDAL PLATFORM

REF	PART NO.	PRV NO.	QTY	DESCRIPTION	SERIAL NO. FROM	NOTES:
1	86217650	34432	1	DIVIDER		
2	86222700	34429	1	PLATFORM		
3	86216380	140713	2	BUSHING, 8MM X 10LG CLY		
4	86007110	72123	2	SWITCH, 25A SPST 125-250V SNAP		
5	86279720	87248	4	WASHER, M4 INT STAR		
6	86272040	57503	4	NUT, M3.5 X 2.8 HEX		
7	86223580	67502	2	ROD, PIVOT, 8.5MM X 77		
8	86222520	34431	1	PEDAL, BRAKE		
9	86277390	70836	4	SCR, M3.5 X 38 PHMS		
10	86233170	20054	3	CLAMP, 3/8 NYLON UL/CSA		
11	86279730	87249	4	WASHER, M5 INT STAR		
12	86277380	70835	4	SCR, M4.8 X 16 PHTF		
13	86222510	34430	1	PEDAL, THROTTLE		
14	86254970	730304	2	SPRING, COMP 18MM OD X 83 X 2		
15	86222780	620047	2	PLATE, PIVOT		
16	86277360	70833	2	SCR, M6 X 10 PH		
17	86274340	70179	11	SCR, M6 X 16 PH		
18	86224360	730325	2	SPACER 12.7MM ID X 2.78W X 6L		
19	86222810	620050	1	PLATE, COVER		
20	86279140	87085	9	WASHER, M6 SPLIT LOCK DIN127B		
21	86288720	57277	2	NUT, M6 NYLOCK PLATED		
22	86250280	66135	1	POTENTIOMETER, 5K OHMS		
23	86222790	620048	1	PLATE, THROTTLE		
24	86278060	70759	2	SET SCR, M4 X 4MM NP		
25	86224350	730305	1	SPACER, 8MM 16L		
26	86277370	70834	1	SCR, M5 X 30 SHCS		
27	86221850	34433	1	LINK, THROTTLE		
28	86218810	23717	1	HARNESS, TWISTER PEDAL		
29	86316310	57086	1	NUT, M5 HEX		
30	86264920	27049	1	CABLE TIE, 7" UL/CSA		
31	86224750	73993	1	SPRING, COMP, .480D X .91	*(16)	
32	86223260	66085	1	PLUNGER, PLATFORM SWITCH	*(16)	

NOTE: Complete platform assembly is available, Part No. 86028310

*SEE SERIAL NUMBER PAGE.

PEDAL PLATFORM

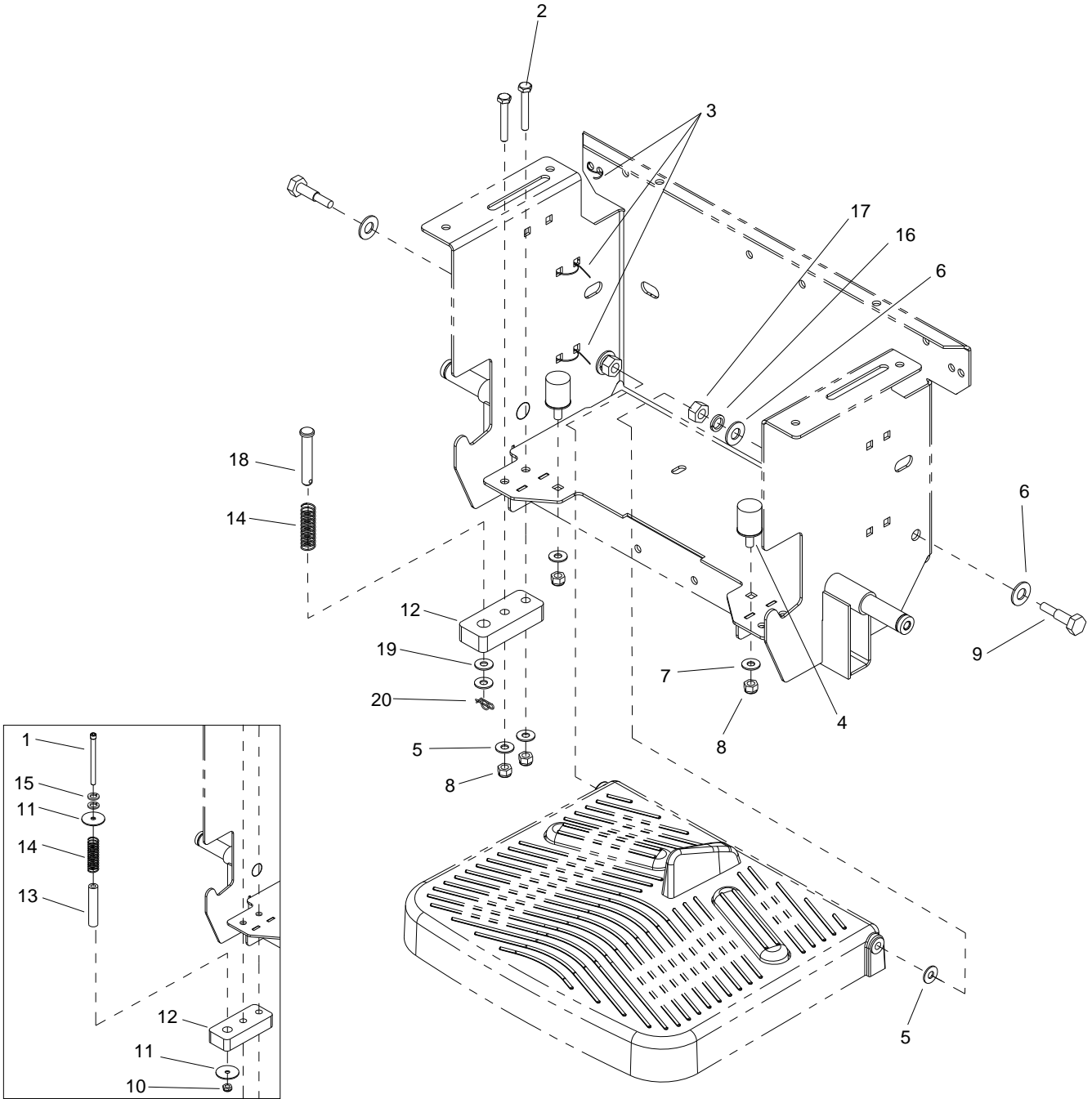

PEDAL PLATFORM

REF	PART NO.	PRV NO.	QTY	DESCRIPTION	SERIAL NO. FROM	NOTES:
1	86277430	70843	1	SCR, 1/4-20 X 3.00 SHCS		
2	86274690	70258	2	SCR, 5/16-18 X 1.5 HHCS GR5PLT		
3	86264920	27049	3	CABLE TIE, 7" UL/CSA		
4	86231070	730328	2	BUMPER, 1 X 1.375 RUBBER		
5	86010670	87029	5	WASHER, 5/16 FLAT SS		
6	86259430	87485	4	M12 FLAT WASHER		
7	86010770	87143	2	WASHER, 7/16ID X1D.08 FLT SS		
8	86270830	57023	4	NUT, 5/16-18 HEX NYLOCK SS		
9	86256470	70852	2	STUB AXLE, M12-1.75 X 45MM		
10	86005810	57245	1	NUT, 1/4-20 HEX NYLOCK SS		
11	86010810	87191	2	WASHER, 1/4" IDX1.0OD FLAT SS		
12	86064480	629993	1	PLATE, SWITCH BASE		
13	86286580	47479	1	SPACER, ACTUATOR SWITCH		WAS 730334
14	86007780	73576	1	SPRING, COMP .60D X2.0L X .045W		
15	86279760	87256	2	WASHER, 1/4 LOCK HICOLLAR PLT		
16	86259440	87486	2	WASHER, M12 SPRING LOCK		
17	86271190	57142	2	NUT, M12 X 1.75 HEX DIN934 PLT		
18	86248920	66487	1	PIN, CLEVIS 1/2 X 2.25	*(16)	
19	86278850	80613	2	WASHER, .506 ID X .94D X .064 NYL	*(16)	
20	86008680	80607	1	COTTER, 1/2" RING	*(16)	

*SEE SERIAL NUMBER PAGE.

REAR COVER

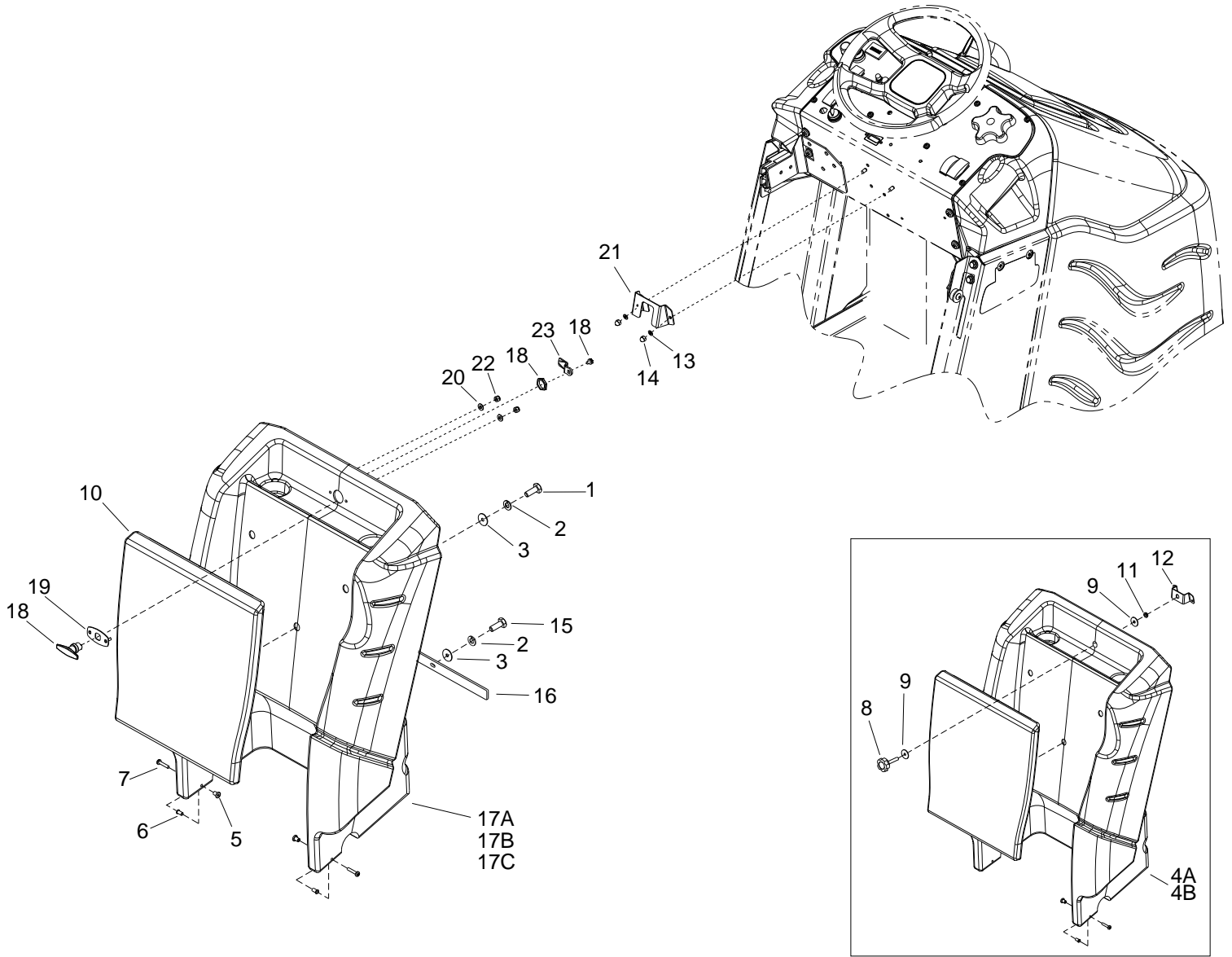

REAR COVER

REF	PART NO.	PRV NO.	QTY	DESCRIPTION	SERIAL NO. FROM	NOTES:
1	86276780	70728	3	SCR, 5/16-18 X 3/4 HHCS SS		
2	86279130	87083	5	WASHER, 5/16 SPLIT LOCK PLTD		
3	86010670	87029	5	WASHER, 5/16 FLAT SS		
4A	86031790	270701	1	COVER, REAR, BASIC		
4B	86031780	270082	1	COVER, REAR, DELUXE		
5	86005860	57273	2	NUT, 1/4-20 X 12MM HEX BARREL		
6	86228980	09152	2	BEARING FLANGED .377ID X .505OD		
7	86275870	70556	2	SCR, 1/4-20 X 1.5" PPHMS SS		WAS 70697
8	86242140	72193	1	KNOB, 3/8-16 X 1.5		
9	86010770	87143	2	WASHER, 7/16ID X 1D X .08FLT SS		
10	86248380	66433	1	PAD, FLAT LEANING		
11	86005630	57022	1	NUT, 3/8-16 HEX NYLOCK THIN SS		
12	86071030	140786	1	BRKT, ASSEMBLY, REAR COVER		
13	86010780	87162	2	WASHER, 1/4 SPLIT LOCK		
14	86271940	57299	2	NUT, 1/4-20 ACORN SS		
15	86006560	70083	2	SCR, 5/16-18 X 1 HHCS SS		
16	86066940	140891	1	BAR, COVER		
17A	86324660	-	1	REAR COVER, BASIC	*(34)	
17B	86324320	-	1	REAR COVER, DELUXE	*(34)	
17C	86324740	-	1	REAR COVER, ORG, DELUXE	*(34)	
18	86324640	-	1	HANDLE, CAM LATCH	*(34)	
19	86324760	-	1	PLATE, COVER LATCH	*(34)	
20	86010630	87013	2	WASHER, 1/4 ID X 5/8 OD SS	*(34)	
21	86324340	-	1	BRKT, REAR COVER	*(34)	
22	86005810	57245	2	NUT, 1/4-20 HEX NYLOCK SS	*(34)	
23	86324650	-	1	PAWL, HANDLE	*(34)	

*See Serial Number Page

SCRUB BRUSH/PAD DRIVER

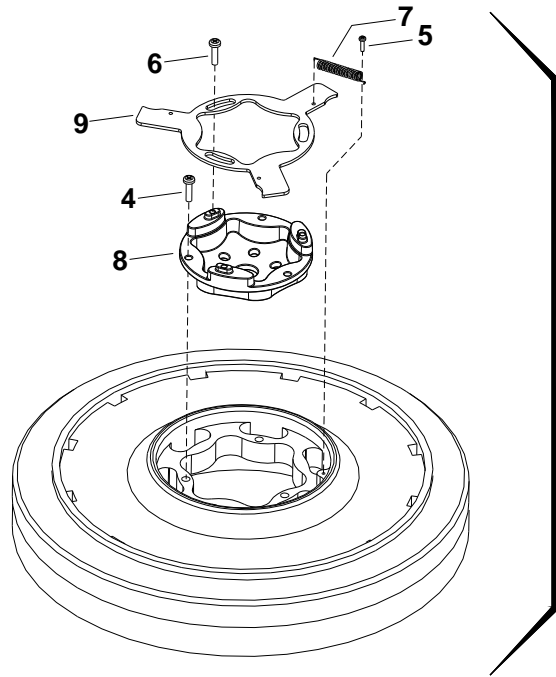
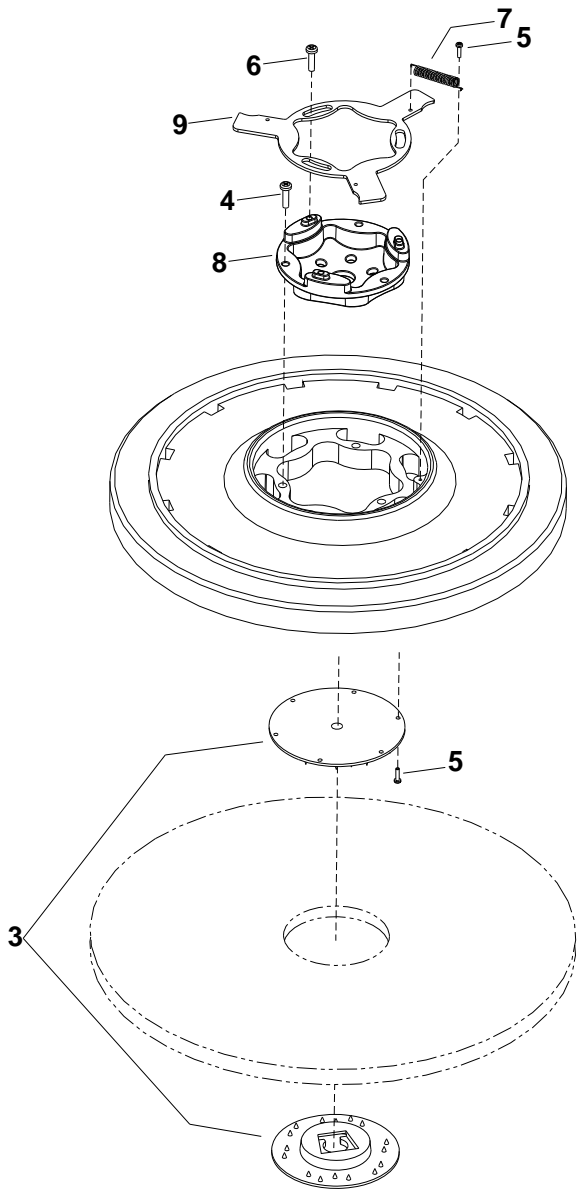

2A
2B
2C
2D

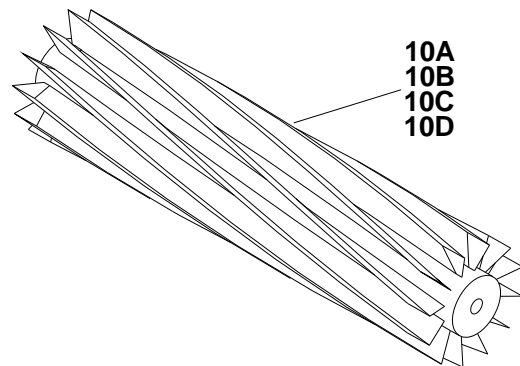

SCRUB BRUSH/PAD DRIVER

REF	PART NO.	PRV NO.	QTY	DESCRIPTION	SERIAL NO. FROM	NOTES:
1	86000170	02400	2	PAD DRIVER, 12" SD		
2A	86000180	02401	2	BRUSH, 12" POLYPROPYLENE SD		
2B	86000190	02402	2	BRUSH, 12" NYLON SD		
2C	86000200	02404	2	BRUSH, 12" MILD GRIT SD		
2D	86283820	02405	2	BRUSH, 12" SUPER AGG SD		
3	86005070	51284	1	LOCK, PAD CENTER SNAP, TWO STEP		
4	86276590	70695	3	SCR, #12 X 1 PPHSMS SS		
5	86276580	70694	1	SCR, 8-32 X 3/4 PTHMS		
6	86276600	70696	3	SCR, #10 X 3/4 PTHSMS SS		
7	86007910	73817	1	SPRING, EXT .31 D X 2.0 L X .03 W SS		
8	86007280	730011	1	SOCKET, DRIVE BRUSH		
9	86005940	62852	1	PLATE, BRUSH RELEASE		
10A	86283890	02500	2	BRUSH, 24" CYL, H-POLYP		
10B	86283900	02501	2	BRUSH, 24" CYL, H-NYLON		
10C	86283910	02502	2	BRUSH, 24" CYL, STCD GRIT		
10D	86283920	02503	2	BRUSH, 24" CYL, SUP AGR		

SCRUB DECK – DISK

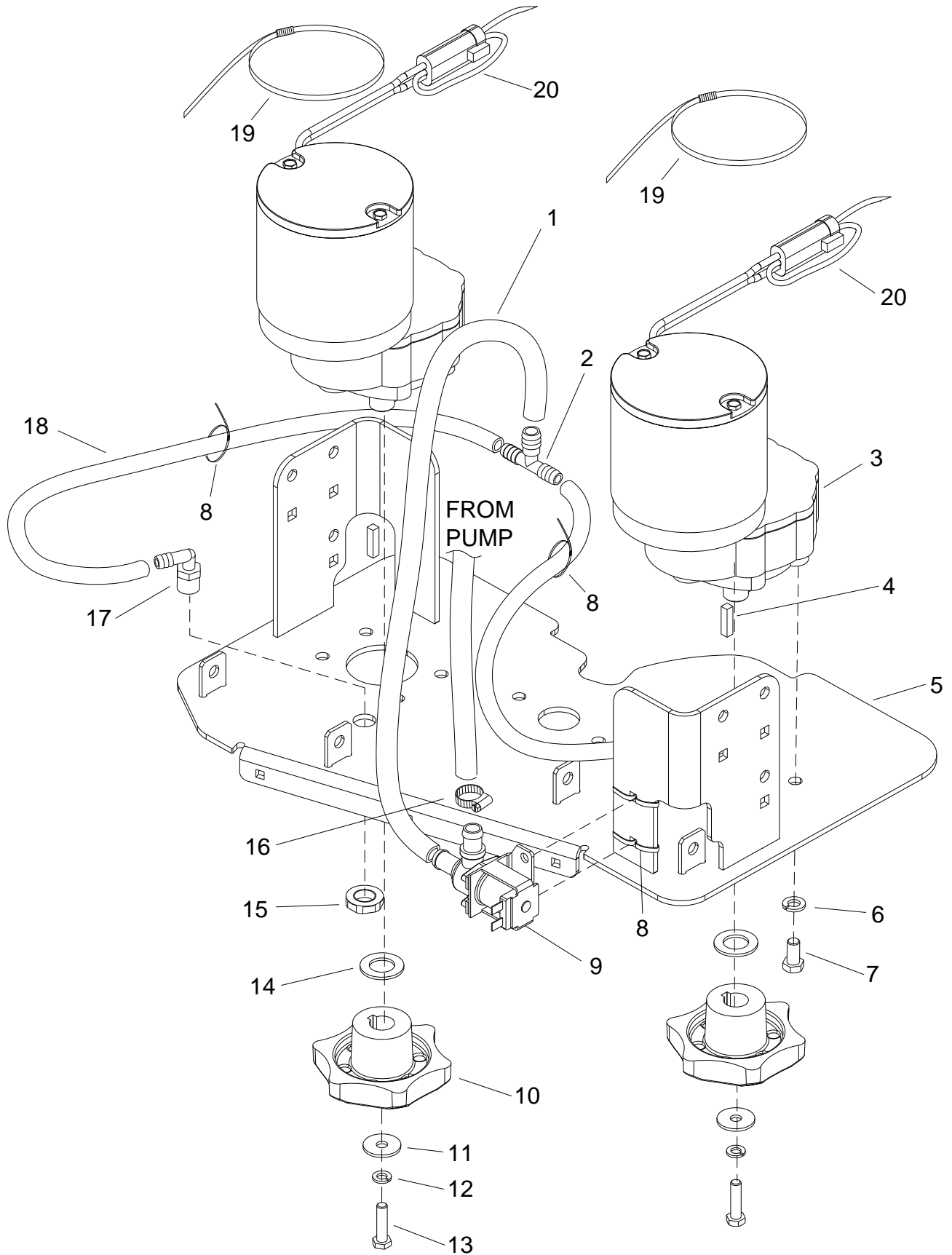

SCRUB DECK – DISK

REF	PART NO.	PRV NO.	QTY	DESCRIPTION	SERIAL NO. FROM	NOTES:
1	86281100	39274	1	HOSE, 1/2ID WIRE BOUND X 8"		
2	86003580	34327	1	FITTING, 1/2"X3/8"X3/8" RED		
3	86005490	53808	2	MOTOR ASM, 36VDC300RPM GEAR		
-	86216200	14739	-	BRUSH SET MOTOR 53808		
4	86004810	48040	2	KEY, 1/4 SQ X 1.00		
5	86093990	730330	1	SCRUBDECK, 24IN		
6	86010790	87163	8	WASHER, 3/8 SPLIT LOCK PLTD		
7	86276970	70774	8	SCR, 3/8-16 X 3/4 HHCS SS		
8	86264920	27049	6	CABLE TIE, 7" UL/CSA		
9	86010600	84199	1	VALVE, SOLENOID, 36VDC, 1/2 BARB		
-	86003460	29260	-	DIAPHRAGM, SRVC PART SLND		SERVICE ONLY
-	86136820	47395	-	SERVICE SLND SPRG KIT		SERVICE ONLY
10	86003420	29220	2	DRIVER, BRUSH SD		
11	86279630	87212	2	WASHER, .344IDX1.130DX.09T PLT		
12	86279130	87083	2	WASHER, 5/16 SPLIT LOCK PLTD		
13	86007020	70673	2	SP SCR, 5/16-18 X 1.25 HHCS SS NP		
14	86279530	87173	2	WASHER, .765IDX1.310DX.09T SS		
15	86271830	57283	2	NUT, 3/8 NPT PLASTIC		
16	86233150	20042	1	CLAMP, 3/8 HOSE (D-SLOT)		
17	86004470	40043	2	HOSEBARB, 3/8MPT X 3/8 90D		
18	86281310	39326	2	HOSE, 3/8ID WIREBOUND X 8"		
19	86002830	27196	2	CABLE TIE, .375 X 24.7		
20	86264940	27051	2	CABLE TIE, 11.38" UL/CSA		

SCRUB DECK – CYLINDRICAL

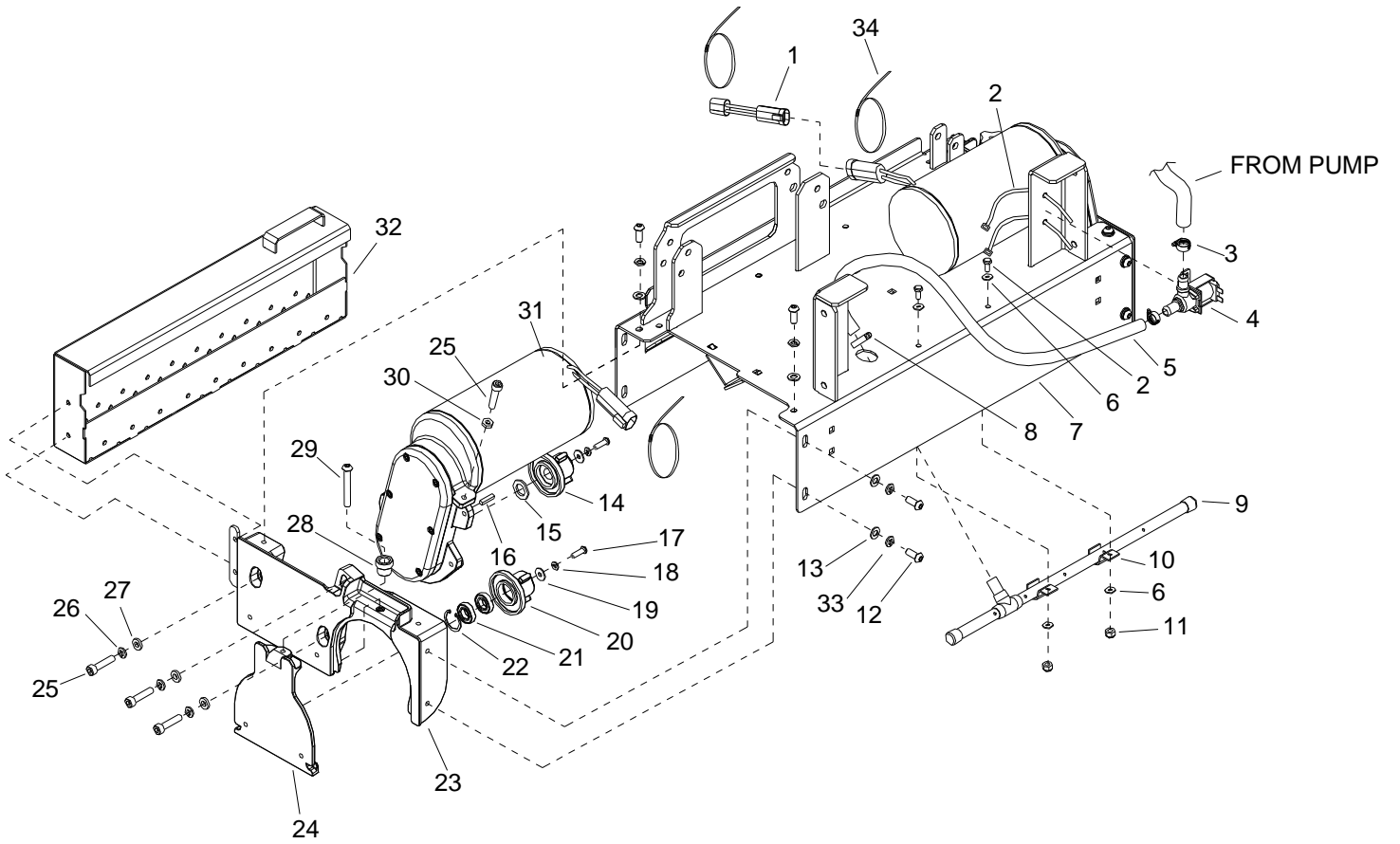

SCRUB DECK - CYLINDRICAL

REF	PART NO.	PRV NO.	QTY	DESCRIPTION	SERIAL NO. FROM	NOTES:
1	86260400	880212	2	WIRE ASM, REV POLARITY JUMPER		
2	86273750	70011	4	SCR, 1/4-20 X 5/8 HHCS SS NP		
3	86233150	20042	2	CLAMP, 3/8 HOSE (D-SLOT)		
4	86010600	84199	4	VALVE, SOLENOID, 36VDC, 1/2 BARB		
5	86282330	39715	1	HOSE, 5/8 ID WIREBOUND X 16"		
6	86010630	87013	4	WASHER, 1/4 ID X 5/8 OD SS		
7	86092520	34441	1	FRAME, SCRUB DECK 24		
8	86233270	20093	2	CLAMP, 7/8" WORM GEAR SS		
9	86033230	54203	1	MANIFOLD, SOLUTION DELIVERY		
10	86233070	20003	2	CLAMP, 1/2 DIA THINWALL CONDUIT		
11	86005810	57245	2	NUT, 1/4-20 HEX NYLOCK SS		
12	86277530	70861	12	SCR, M8 X 1.25 X 20 LG BSHCS SS		
13	86010670	87029	12	WASHER, M8 FLAT DIN125A PLT		
14	86219440	41487	2	HUB, TRI-STAR BRUSH DRIVE		
15	86279780	87488	2	WASHER, M16 SMALL OD FLAT PLTD		
16	86004820	48041	2	KEY, 3/16 SQ X 7/8 CRS		
17	86277870	70854	4	SCREW, M6-1.0 X 20 LG BHSCS SS		
18	86279140	87085	4	WASHER, M6 SPLIT LOCK DIN127B		
19	86279770	87487	4	WASHER, M6 LARGE OD FLAT PLTD		
20	86219450	41488	2	HUB, TRI-STAR BRUSH IDLER		
21	86228960	09149	4	BEARING, BALL 15MM X 28MM X 7W		
22	86223520	67598	2	RING, 28MM INTERNAL SNAP		
23	86219290	34418	2	HOUSING, SCRUB PLUS DRIVE		
24	86217710	29268	2	DOOR, CYLINDRICAL BRUSH		
25	86277880	70855	8	SCREW, M8-1.25 X 35 LG SHCS SS		
26	86137310	87098	6	WASHER, M8 SPLIT LOCK		
27	86279790	87489	6	WASHER, M8 (THICK) FLAT PLTD		
28	86242120	48090	2	KNOB, 1.0 OD X 5-16-18		
29	86277150	70797	2	SCR, 5-16-18 X 2 BSHCS SS		
30	86222330	57504	2	NUT, M8 X 1.25 HEX JAM SS		
31	86222110	53267	2	MOTOR, SP BRUSH DRIVE, 36V, 3/4HP		
-	86001360	140394	-	BRUSH SET		SRVC ONLY
-	86218170	35369	-	GASKET, GEARBOX		
32	86092840	41535	1	HOPPER, CYL, DECK		
33	86279130	87083	12	WASHER, 5/16 SPLIT LOCK PLTD		
34	86264940	27051	3	CABLE TIE, 11.38" UL/CSA		

SCRUB DECK AQUA-MIZER™

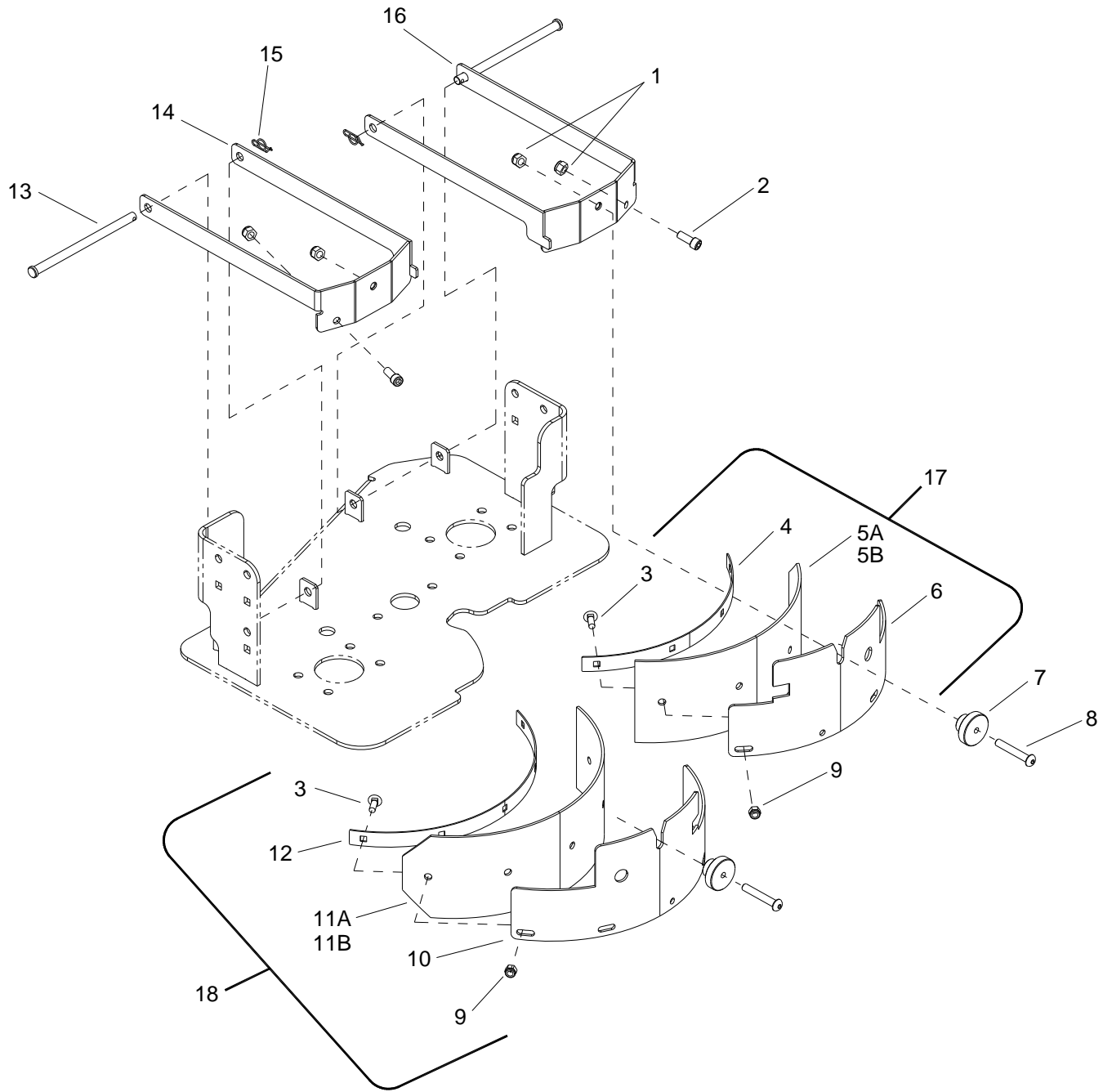

SCRUB DECK AQUA-MIZER™

REF	PART NO.	PRV NO.	QTY	DESCRIPTION	SERIAL NO. FROM	NOTES:
1	86270830	57023	4	NUT, 5/16-18 HEX NYLOCK SS		
2	86277050	70782	2	SCR, 5/16-18 X 3/4 SHCS		
3	86276950	70772	9	SCR, 1/4-20 X 3/4 CARRIAGE SS		
4	86066430	140747	1	BAND, RIGHT AQUAMIZER		
5A	86001540	140753	1	BLADE, AQUAMIZER, 12IN RGT		
5B	86283550	140939	1	BLADE, AQMZR 12 RT URETHANE		
6	86071000	140779	1	BRKT, AQUAMIZER BLADE, RGT		
7	86219690	48080	2	KNOB, 1.5 OD X 5/16-18		
8	86277230	70815	2	SCR, 5/16-18 X 2.25 BSHCS SS		
9	86005810	57245	9	NUT, 1/4-20 HEX NYLOCK SS		
10	86070990	140778	1	BRKT, AQUAMIZER BLADE, LEFT		
11A	86001520	140752	1	BLADE, AQUAMIZER, 12IN LEFT		
11B	86283560	140940	1	BLADE, AQMZR 12 LT URETHATNE		
12	86066420	140746	1	BAND, LEFT AQUAMIZER		
13	86272540	66465	2	PIN, CLEVIS, 3/8 X 6.12, PLTD		
14	86091800	140776	1	BRKT, AQUAMIZER MTG, LEFT		
15	86008670	80606	2	COTTER, 3/8" RING		
16	86091790	140774	1	BAND, LEFT AQUAMIZER		
17	86024990	47456	-	AQUAMIZER RIGHT ASM. CHARIOT		
18	86025000	47457	-	AQUAMIZER LEFT ASM. CHARIOT		

SIDE SQUEEGEE – CYLINDRICAL

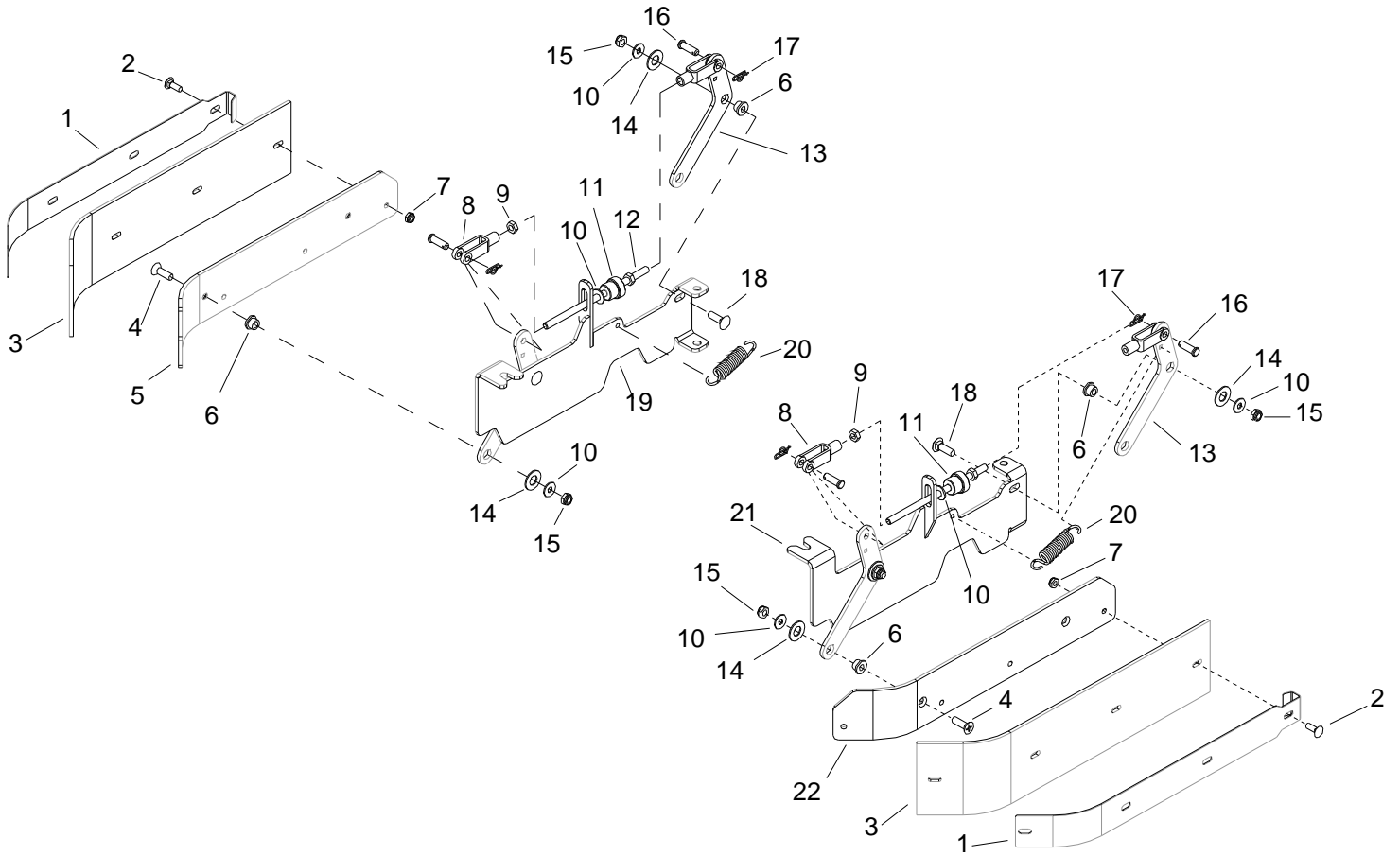

SIDE SQUEEGEE - CYLINDRICAL

REF	PART NO.	PRV NO.	QTY	DESCRIPTION	SERIAL NO. FROM	NOTES:
1	86066510	140838	2	BAND, SIDE SQG, 24		
2	86276950	70772	8	SCR, 1/4-20 X 3/4 CARRIAGE SS		
3	86283480	140039	2	BLADE, SQUEEGEE, SIDE, 24		
4	86277120	70792	4	SCR, 5/16-18 X 1 PFHMS SS		
5	86071340	140848	1	BRKT, SKIRT, SQG, LH		
6	86228990	09153	8	BEARING, FLNGD, .314 ID X .502 OD		
7	86271870	57290	8	NUT, 1/4-20 HEX NYLCK THIN SS		
8	86226430	80636	4	CLEVIS, 5/16" YOKE END 5/16-18		
9	86271170	57138	4	NUT, 5/16-18 JAM		
10	86010670	87029	10	WASHER, 5/16 FLAT SS		
11	86242120	48090	2	KNOB, 1.0 OD X 5/16-18		
12	86086570	67600	1	ROD, 5/16-18 X 6.5 ADJ		
13	86079160	620071	4	PLATE, SQG LINKAGE ARM		
14	86259420	87232	8	WASHER, THRUST .51 ID X 1 OD BRO		
15	86271840	57285	8	NUT, 5/16-18 HEX NYLOCK THIN SS		
16	86272550	66485	4	PIN, CLEVIS, 5/16 X 1.00 PLTD		
17	86008660	80605	4	COTTER, 5/16" RING		
18	86277130	70795	4	SCR, 5/16-18 X 1.00 CARRIAGE SS		
19	86091600	140061	1	BRKT, SIDE SQG, WELDMENT, LH		
20	86226830	73268	2	SPRING, EXT .68 D X 3.00 L X .098 W		
21	86091570	140021	1	BRKT, SIDE SQG, WELDMENT, RH		
22	86071280	140836	1	BRKT, SKIRT, SQG, RH		

SCRUB DECK - SIDE SQUEEGEE - CYLINDRICAL

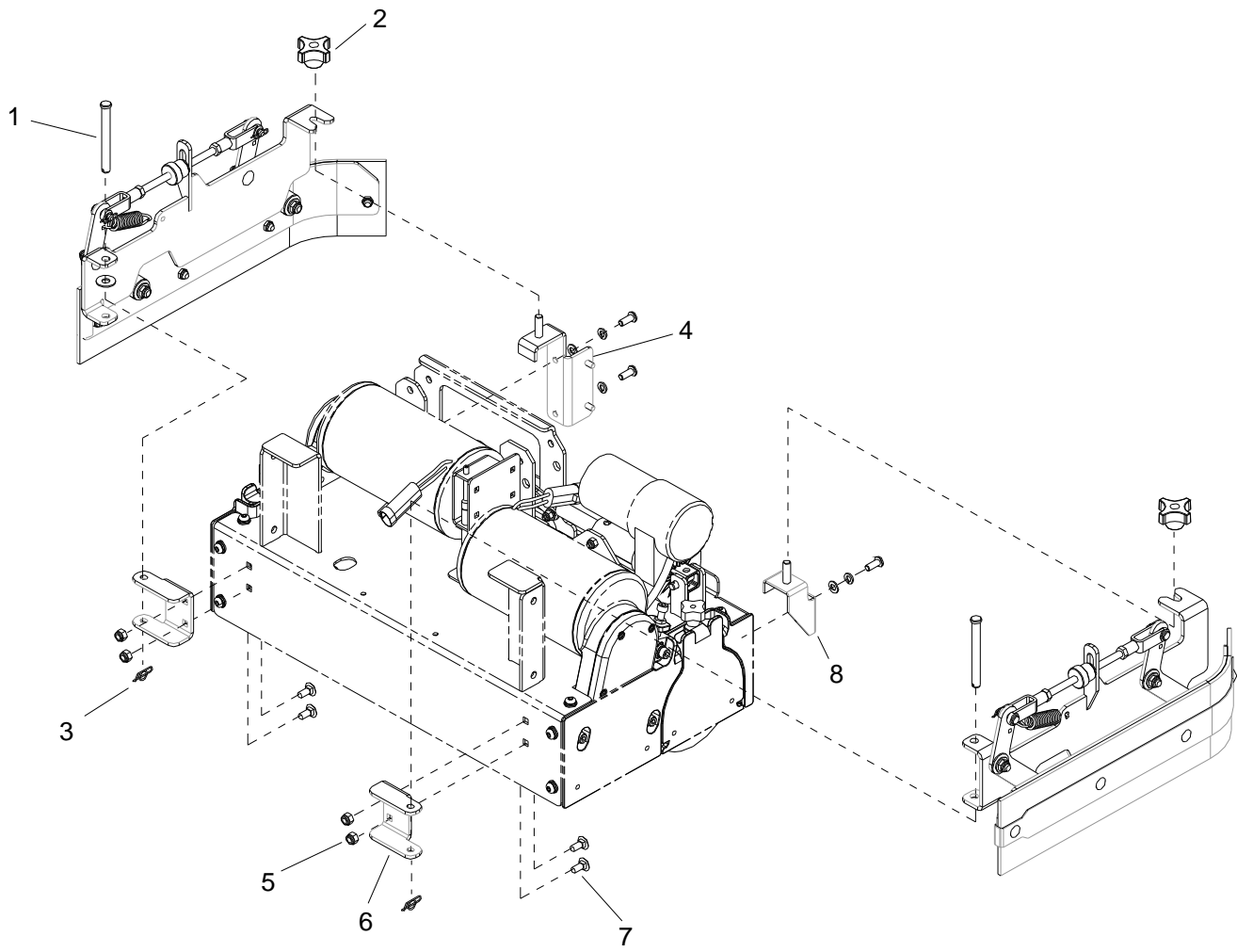

SCRUB DECK - SIDE SQUEEGEE - CYLINDRICAL

REF	PART NO.	PRV NO.	QTY	DESCRIPTION	SERIAL NO. FROM	NOTES:
1	86249050	82058	2	PIN, CLEVIS 3/8 X 3.50 PLTD		
2	86009200	81535	2	KNOB, 3/8-16 4 PRONG ALUM		
3	86008670	80606	2	COTTER, 3/8" RING		
4	86068570	140050	1	BRKT, HOPPER ALIGNMENT		
5	86270830	57023	4	NUT, 5/16-18 HEX NYLOCK SS		
6	86071350	140849	2	BRKT, SIDE SQG MOUNT		
7	86276070	70593	4	5/16-18 X 3/4 CARRIAGE SS		
8	86071440	140864	1	BRKT, SIDE SQUEEGEE, LFT		

SCRUB DECK SKIRTS

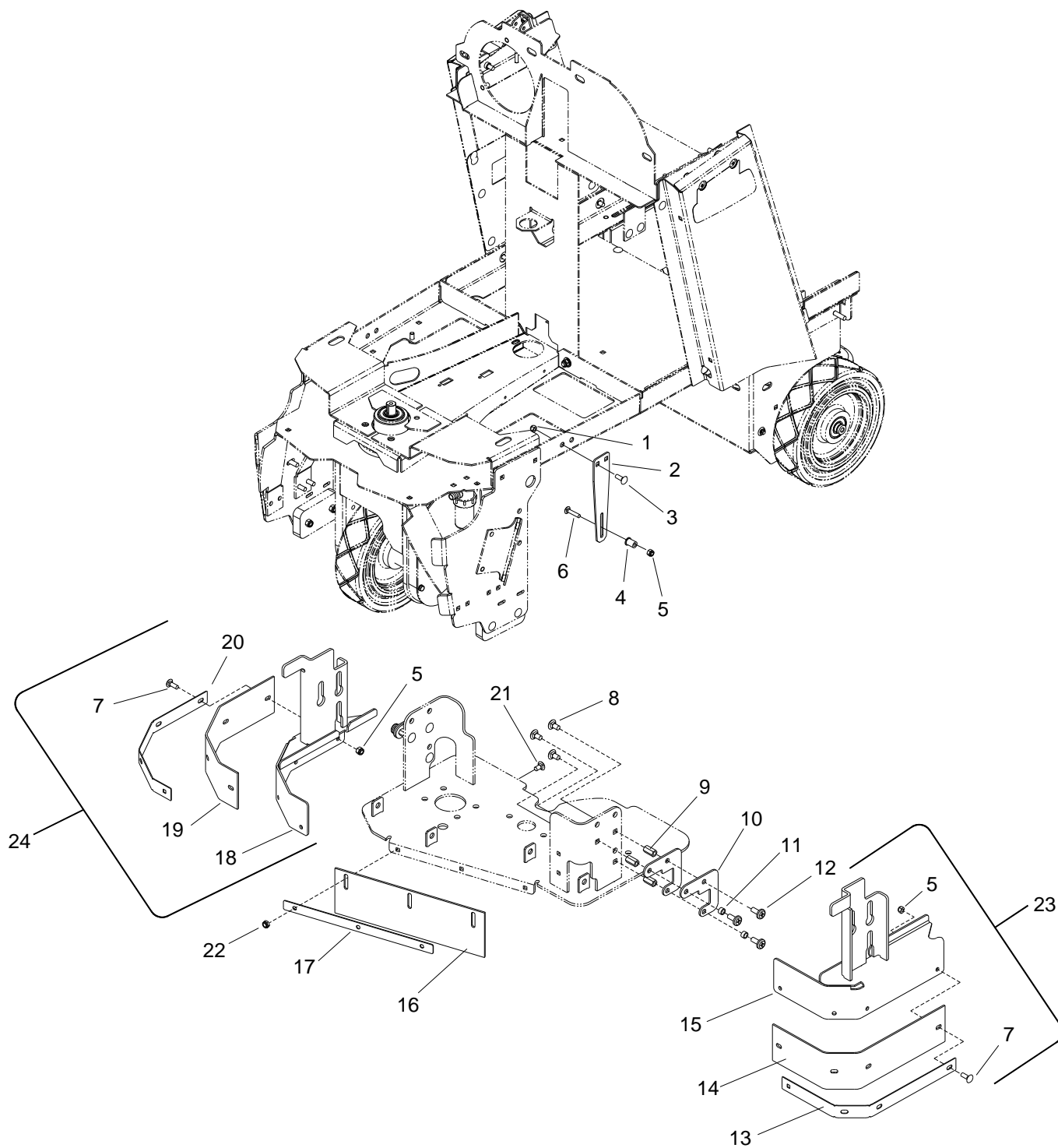

SCRUB DECK SKIRTS

REF	PART NO.	PRV NO.	QTY	DESCRIPTION	SERIAL NO. FROM	NOTES:
1	86270830	57023	4	NUT, 5/16-18 HEX NYLOCK SS		
2	86070960	140773	2	BRKT, SKIRT STOP, SCRUBDECK		
3	86276070	70593	4	SCR, 5/16-18 X 3/4 CARRIAGE SS		
4	86228900	09138	2	BEARING FLANGED, .252IDX.503OD		
5	86005810	57245	6	NUT, 1/4-20 HEX NYLOCK SS		
6	86276330	70634	2	SCR, 1/4-20 X 1.25 CARRIAGE BZ		
7	86276950	70772	8	SCR, 1/4-20 X 3/4 CARRIAGE SS		
8	86277410	70840	6	SCR, 5/16-18 X 5/8 CARRIAGE SS		
9	86271950	57300	6	NUT, 5/16-18 X 1 COUPLING SS		
10	86079130	620068	4	PLATE, SKIRT, SPACER		
11	86007650	730329	4	SPACER, .438D X .317ID X .25L		
12	86007070	70849	6	SCR, 5/16-18 X 1.00 PTMS SS		
13	86066460	140769	1	BAND, SKIRT, LEFT		
14	86001560	140754	1	BLADE, SKIRT, SCRBDCK, 24IN LFT		
15	86091770	140765	1	BRKT, SKIRT SCRUBDECK, LEFT		
16	86001700	140780	1	BLADE, SKIRT, SCRUBDECK, FRONT		
17	86066480	140781	1	BAND, SKIRT, SCRUBECK, FRONT		
18	86091780	140766	1	BRKT, SKIRT, SCRUBDECK, RIGHT		
19	86001570	140755	1	BLADE, SKIRT, SCRBDCK, 24IN RGT		
20	86066470	140770	1	BANC, SKIRT, RIGHT		
21	86277500	70853	3	SCR, 1/4-20 X 5/8 CARR SS		
22	86271870	57290	3	NUT, 1/4-20 HEX NYLOCK THIN SS		
23	86026470	47459	-	KIT, SKIRT LEFT		SERVICE ONLY
24	86026460	47458	-	KIT, SKIRT RIGHT		SERVICE ONLY

SCRUB DECK LIFT

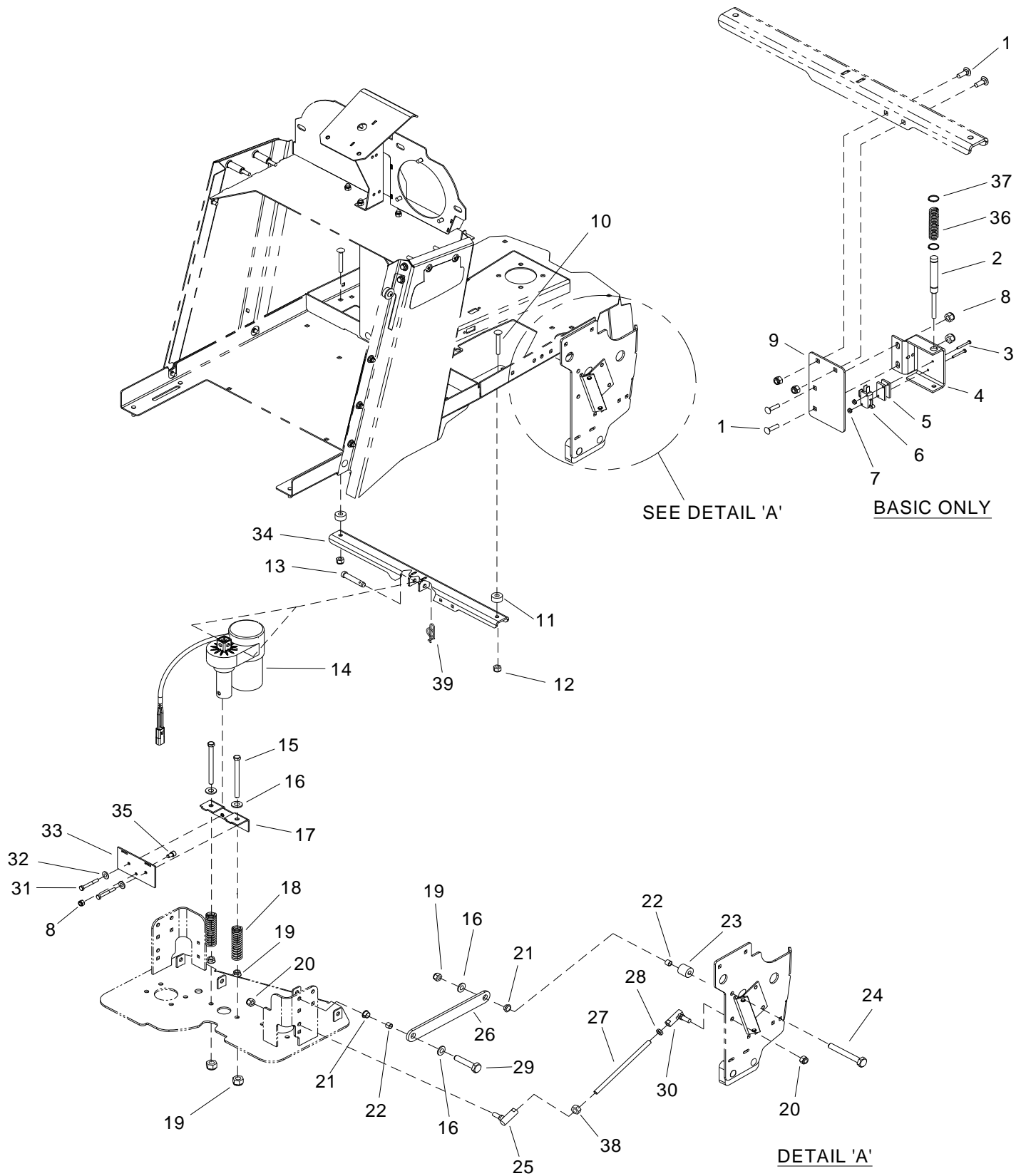

SCRUB DECK LIFT

REF	PART NO.	PRV NO.	QTY	DESCRIPTION	SERIAL NO. FROM	NOTES:
1	86276950	70772	4	SCR, 1/4-20 X 3/4 CARRIAGE SS		
2	86223270	66482	1	PLUNGER, MICRO SWITCH	*(13)	
3	86276010	70580	2	SCR, 4-40 X 1.0 PPHMS		
4	86072460	14387	1	BRKT, MICROSWITCH MOUNT		
5	86087520	73456	2	SPACER, L2020B PLUNGER SWITCH		
6	86007160	72157	1	SWITCH, 10A ROLLER MINI		
7	86271280	57163	2	NUT, 4-40 W/STAR WASHER		
8	86005810	57245	6	NUT, 1/4-20 HEX NYLOCK SS		
9	86079150	620070	1	PLATE, MTG, DECK LIMIT		
10	86277030	70780	2	SCR, 5/16-18 X 1.25 CARRIAGE SS		
11	86224370	730335	2	SPACER, 1 OD X .391 ID X .500		
12	86270830	57023	2	NUT, 5/16-18 HEX NYLOCK SS		
13	86272460	66268	1	PIN, CLEVIS 5/16 X 3.00 PLTD	*(26)(27)(28) (29)(30)	WAS 80637
-	86008720	80637	1	PIN, CLEVIS 3/8 X 2.38	*(22)	WAS 66369
14	86011950	-	1	ACTUATOR, 36VDC 3.5 STRK	*(21)	WAS 05250
15	86275510	70494	2	SCR, 3/8-16 X 4.5" HHCS GR5		
16	86010770	87143	2	WASHER, 7/16ID X IDX.08 FLT SS		
17	86070810	140739	1	BRKT, ACTUATOR SPGS, SCRUBDECK		
18	86255450	81376	2	SPRING COMP .96D X 4.0L X .135W		
19	86005630	57022	4	NUT, 3/8-16 HEX NYLOCK THIN SS		
20	86271530	57216	2	NUT, 3/8-24 HEX NYLOCK		
21	86009050	81324	6	BEARING, 1/2 ID X 11/32L NYLON		
22	86008460	80102	4	SPACER, .500OD X .391ID C .400		
23	86224380	730336	2	SPACER, 1 OD X 0.391 ID X 1.063		
24	86274010	70070	2	SCR, 3/8-16 X 2 HHCS		
25	86001320	140353	2	BALL JOINT ASSY, 3/8-24 LH		
26	86077330	31373	2	LINKAGE, .25 X 1.25 X 9.25		
27	86223540	66483	2	ROD, SCRUB LIFT	*(17)	
28	86005800	57217	2	NUT, 3/8-24 HEX JAM		
29	86276920	70755	2	SCR, 3/8-16 X 1 HHCS SS NP		
30	86008810	80697	2	BALL JOINT ASY, 3/8-24 RH		
31	86273850	70022	2	SCR, 1/4-20 X 2 HHCS		
32	86010780	87162	2	WASHER, 1/4 SPILT LOCK PLTD		
33	86079030	620058	1	PLATE, ACTUATOR SPR, SCRUBDECK		
34	86091760	140741	1	BRKT, ACTUATOR MTG, SCRUBBER		
35	86274110	70094	2	SCR, 1/4-20 X 1/2 SHCS		
36	86007780	73576	1	SPRING, COMP .60D X 2.0L X .045W		
37	86270270	27721	2	CLIP, RETAINING 7/16		
38	86005830	57263	2	NUT, 3/8-24 UNF LH		
39	86008660	80605	1	COTTER, 5/16" RING	*(26)(27)(28) (29)(30)	WAS 80606
-	86008670	80606	1	COTTER, 3/8" RING	*(22)	

* SEE SERIAL NUMBER PAGE

SCRUB DECK MOUNTING- CYLINDRICAL

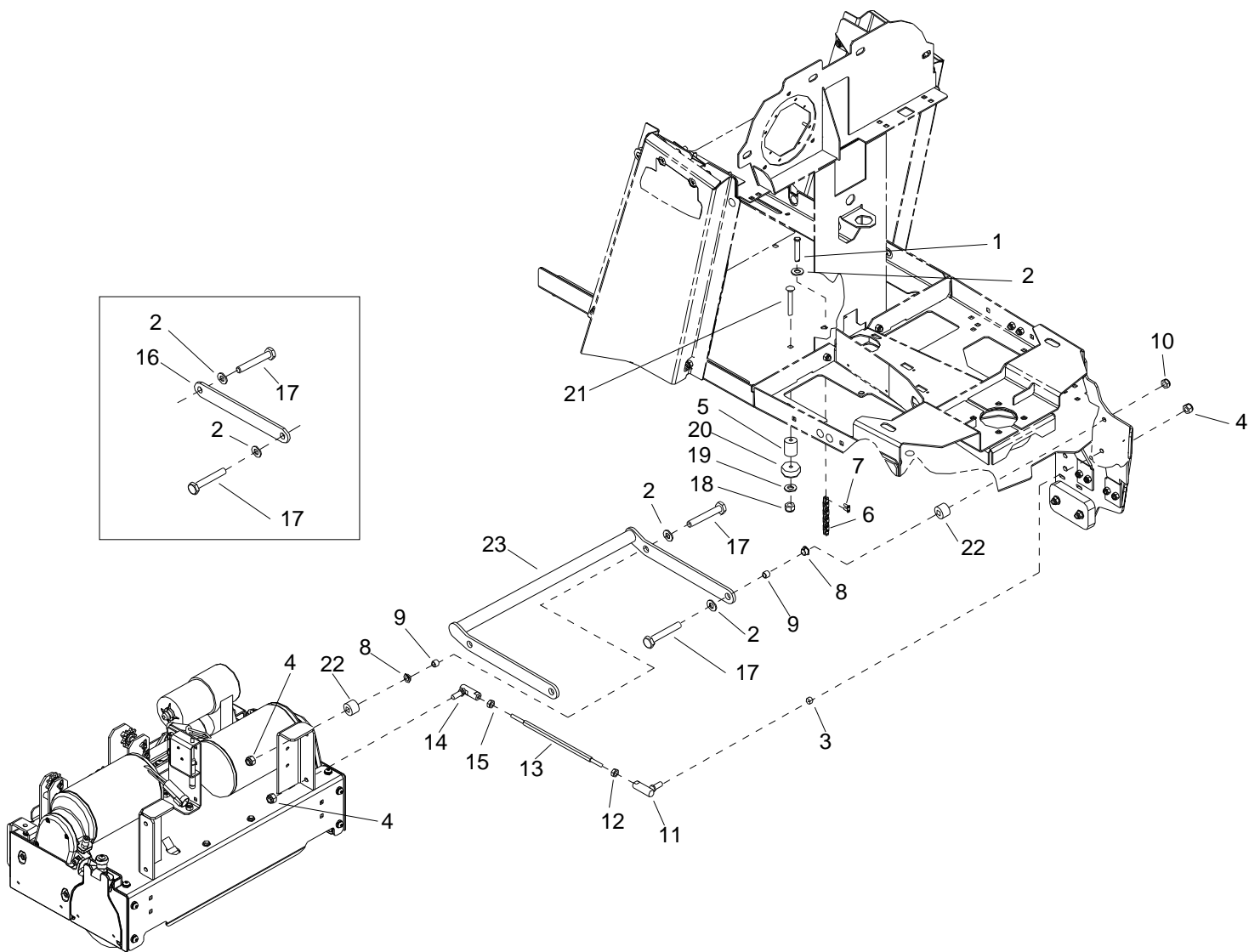

SCRUB DECK MOUNTING - CYLINDRICAL

REF	PART NO.	PRV NO.	QTY	DESCRIPTION	SERIAL NO. FROM	NOTES:
1	86272380	66217	1	PIN, CLEVIS 3/8 X .75 PLTD		
2	86010770	87143	5	WASHER, 7/16 ID X 1D X .08 FLT SS		
3	86087580	73606	2	SPACER, 1/2 OD X .058 ID X .26 LG CRS		
4	86271530	57216	6	NUT, 3/8-24 HEX NYLOCK		
5	86224380	730336	2	SPACER, 1 OD X .391 ID X 1.063		
6	86232680	270114	REF	CHAIN, #41, 1/2" PITCH X 34		
7	86009400	81873	1	CHAIN, #41, 1/2" P MASTER LINK		
8	86009050	81324	4	PIN, CLEVIS 3/8 X .75 UNPLTD		
9	86008460	80102	4	SPACER, .500 OD X .391 ID X .400		
10	86005630	57022	2	NUT, 3/8-16 HEX NYLOCK THIN SS		
11	86008810	80697	2	BALL JOINT ASY, 3/8-24 RH		
12	86005800	57217	2	NUT, 3/8-24 HEX JAM		
13	86223540	66483	2	ROD, SCRUB LIFT HEX		WAS 67415 ROUND
14	86001320	140353	2	BALL JOINT ASSY, 3/8-24 LH		
15	86005830	57263	2	NUT, 3/8-24 UNF LH		
16	86077330	31373	2	LINKAGE, .25 X 1.25 X 9.25		
17	86274660	70255	4	SCR, 3/8-16 X 1.5 HHCS GR5 PLTD		
18	86271840	57285	2	NUT, 5/16-18 HEX NYLOCK THIN SS		
19	86010670	87029	2	WASHER, 5/16 FLAT SS		
20	86231090	80809	2	BUMPER, RUBBER 5/16" ID X 1.50		
21	86276690	70715	2	SCR, 5/16-18 X 1.75 CARR SS		
22	86224370	730335	4	SPACER, 1 OD X .391 ID X .500 LG		
23	86093180	51415	1	LINKAGE ASM, DECK ARM	*(9)	

*SEE SERIAL NUMBER PAGE.

SCRUB DECK ACTUATOR - CYLINDRICAL

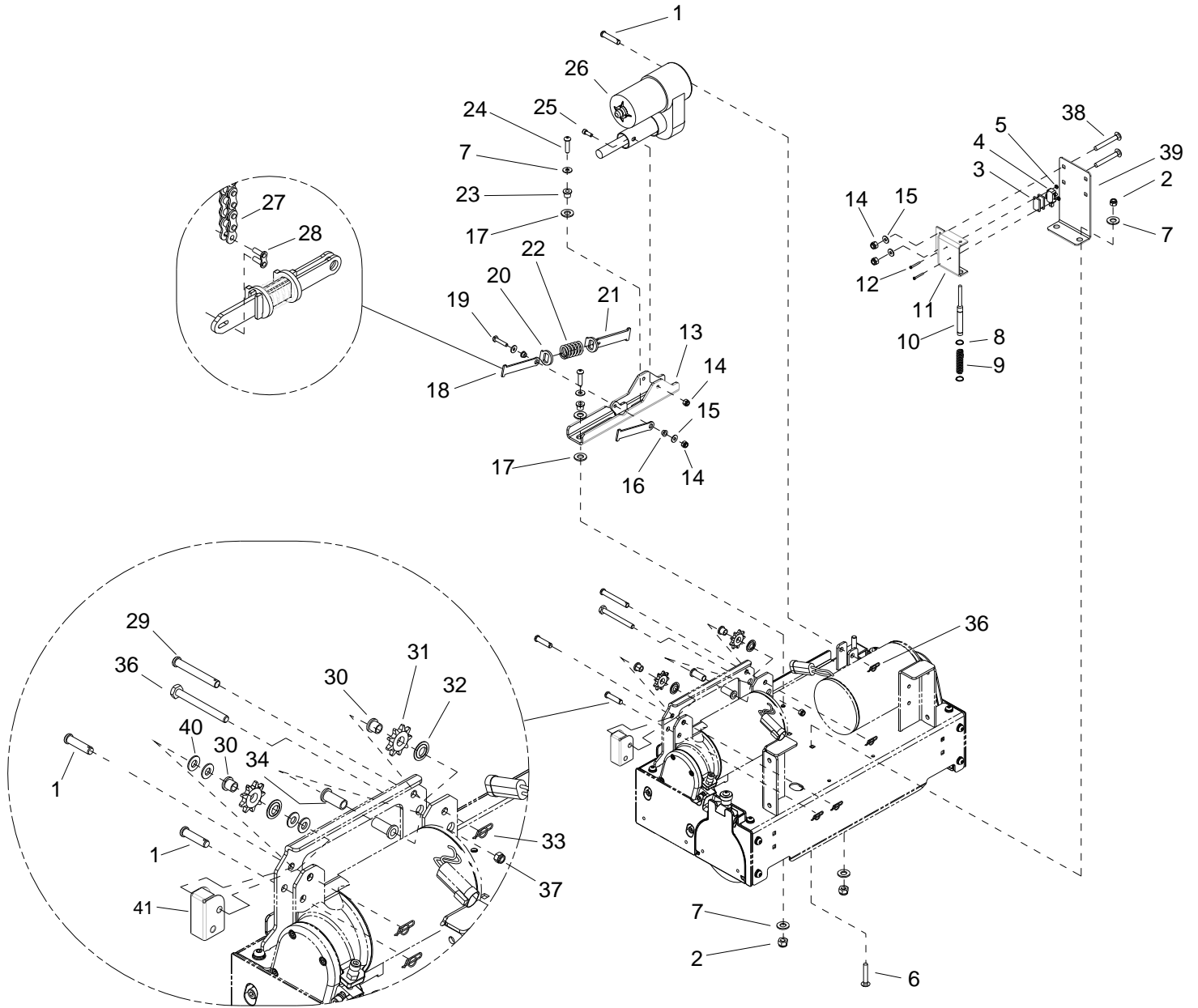

SCRUB DECK ACTUATOR - CYLINDRICAL

REF	PART NO.	PRV NO.	QTY	DESCRIPTION	SERIAL NO. FROM	NOTES:
1	86248980	81438	3	PIN, CLEVIS 3/8 X 1.75 PLTD		
2	86270830	57023	2	NUT, 5/16-18 HEX NYLOCK SS		
3	86087520	73456	2	SPACER, L2020B PLUNGER SWITCH		
4	86007160	72157	1	SWITCH, 10A ROLLER MINI		
5	86271280	57163	2	NUT, 4-40 W/STAR WASHER		
6	86276070	70593	2	SCR, 5/16-18 X 3/4 CARRIAGE SS		
7	86010670	87029	4	WASHER, 5/16 FLAT SS		
8	86270270	27721	2	CLIP, RETAINING 7/16		
9	86007780	73576	1	SPRING, COMP .60 D X 2.0 L X .045 W		
10	86223270	66482	1	PLUNGER, MICROSWITCH		
11	86072460	14387	1	BRKT, MICROSWITCH MOUNT		
12	86276010	70580	2	SCR, 4-40 X 1.0 PPHMS		
13	86091840	140850	1	BRKT, ACTUATOR SLIDER		
14	86005810	57245	5	NUT, 1/4-20 HEX NYLOCK SS		
15	86010630	87013	4	WASHER, 1/4 ID X 5/8 OD SS		
16	86231360	14744	2	BUSH, BRZ FLG .25 X .38 X .25		
17	86259420	87232	4	WASHER, THRUST .51 ID X 1 OD BRO		
18	86066910	140851	2	BAR, COMP. SPRING RETAINER, OS		
19	86273820	70019	1	SCR, 1/4-20 X 1.25 HHCS SS		
20	86090330	87258	2	WASHER, .804 ID X 1.25 OD X .179		
21	86066920	140852	1	BAR, COMP. SPRING RETAINER, IS		
22	86278400	730351	1	SPRING, COMP., 1.1 OD X 2.25 L X .148		
23	86228840	09124	2	BEARING, FLANGED .314 ID X .502 OD		
24	86276760	70724	2	SCR, 5/16-18 X 1.25 BSHCS SS		
25	86006910	70443	2	SCR, 1/4-20 X 5/8 SHCS		
26	86011950	-	1	ACTUATOR, 36VDC, 3.5 IN STRK	*(21)	WAS 05250
27	86232680	270114	1	CHAIN, #41, 1/2" PITCH X 34D		
28	86009400	81873	1	CHAIN, #41, 1/2" MASTER LINK		
29	86272520	66392	1	PIN, CLEVIS 3/8 X 2.75 PLTD		
30	86229000	09154	2	BEARING FLG .377 ID X .502 OD X .501		
31	86255650	81627	2	SPROCKET, #41 1/2"P 9T		
32	86222270	57276	2	NUT, PUSH FLAT RD .51 ID		
33	86008670	80606	4	COTTER, 3/8" RING		
34	86228910	09139	2	BEARING, FLANGED .377 ID X .502 OD		
35	OPEN	-	-	-		
36	86276400	70642	1	SCR, 3/8-16 X 3 HHCS SS		
37	86005630	57022	1	NUT, 3/8-16 HEX NYLOCK THIN SS		
38	86277500	70853	2	SCR, 1/4-20 X 5/8 CARR SS		
39	86071450	140865	1	BRKT, STRIKER		
40	86010680	87030	4	WASHER, 3/8 ID X 3/4 OD NYLON		
41	86290090	-	1	GUARD, CHAIN	*(1)	

*SEE SERIAL NUMBER PAGE.

SOLUTION - CYLINDRICAL

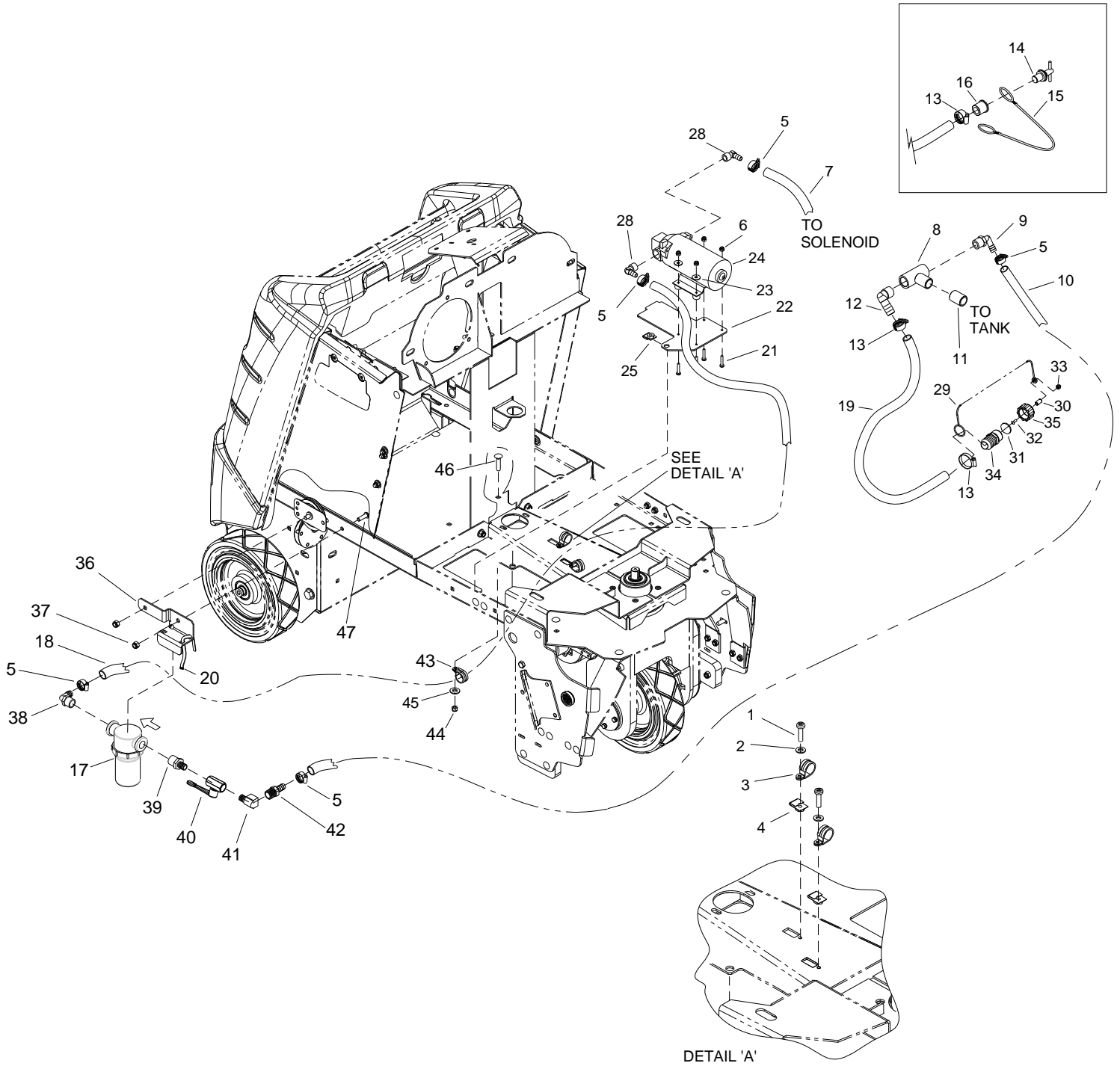

SOLUTION- CYLINDRICAL

REF	PART	PRV NO.	QTY	DESCRIPTION	SERIAL NO.	NOTES:
1	86274070	70086	2	SCR, 10-24 X 1/2 PPHMS		
2	86010650	87018	2	WASHER, #10 X 9/16 OD		
3	86233390	80887	2	CLAMP, 7/8 DIA "P" CUSHIONED		
4	86270860	57028	2	NUT, 10-24 U-TYPE SPEED		
5	86233150	20042	5	CLAMP, 3/8 HOSE (D-SLOT)		
6	86270990	57090	4	NUT, 10-32 HEX NYLOCK SS		
7	86282320	39710	1	HOSE, 1/2ID WIRE BOUND X 49"		
8	86198050	81923	1	TEE, 3/4 FPT		
9	86240390	40075	1	HOSEBARB, 3/4 MPT X 1/2 90D		
10	86280910	39174	1	HOSE, 1/2ID WIRE BOUND X 23"		
11	86247760	80960	1	NIPPLE, 3/4 CLOSE PVCE		
12	86240600	41526	1	HOSEBARB, 3/4 MPTX1, HOSE 90DEG		
13	86233110	20018	2	CLAMP, 1.00" WORM GEAR		
14	86009700	82267	1	PLUG, 5/8" DRAIN HOSE		
15	86270510	51457	1	LANYARD, .093 X 6 NYLON		WAS 78499
16	86001600	40076	1	SLEEVE, .63 ID X 1.0 OD		
17	86256120	730368	1	STRAINER, 1/2 FPT 100 MESH		
-	86005870	59021	-	O-RING, FILTER SEAL RON-VIK		SERVICE ONLY
-	86136800	73839	-	SCREEN, 80 MESH STRAINER DEEP		SERVICE ONLY
18	86282370	39735	1	HOSE, 1/2ID WIRE BOUND X 40"		
19	86004310	39505	1	HOSE, 1.0 X 18.0 DRAIN		
20	86264920	27049	2	CABLE, TIE. 7" UL/CSA		
21	86274410	70195	4	SCR, 10-32 X 1.25 PPHMS SS		
22	86070690	140724	1	BRKT, SOLUTION PUMP		
23	86010650	87018	4	WASHER, #10 X 9/16 OD		
24	86006100	65176	1	PUMP ASM, 36V		
25	86271820	57270	1	NUT, 5/16-18 CAPTIVE "J" PLTD		
26	86279130	87083	1	WASHER, 5/16 SPLIT LOCK PLTD		
27	86276780	70728	1	SCR, 5/16-18 X 3/4 HHCS SS		
28	86197940	40027	2	HOSEBARB, 3/8MPTX1/2 90D DL		
29	86246090	51461	1	LANYARD, .093 X 6", LOOP - .26 EYE	*(11)	
30	86254320	730400	1	SPACER, .17 ID X .25 OD X 3/16 LG	*(11)	
31	86259450	87507	1	WASHER, 1.0 D X .1 THK, SEAL	*(11)	
32	86252730	70887	1	SCR, 8-32 X 1/2 BHCS SST	*(11)	
33	86248010	57312	1	NUT, 8/32 ACORN CAP, PLATED	*(11)	
34	86226950	40109	1	1" HOSEBARB X 3/4" GHT NYLON	*(11)	
35	86073960	22104	1	CAP, 3/4" GHT W/.17 HOLE	*(11)	
36	86068780	140202	1	BRKT, STRAINER MNT	*(25)	
37	86270830	57023	2	NUT, 5/16-18 HEX NYLOCK SS	*(25)	
38	86001530	40039	1	HOSE BARB, 1/2 MPT X 1/2 HOSE 90	*(25)	
39	86188210	11-800354	1	NIP, 1/2 X 3/8 HEX BR	*(25)	
40	86225680	84201	1	VALVE, 3/8" FPT BALL	*(25)	
41	86197420	31026	1	ELBOW, 3/8" NPT STREET	*(25)	
42	86197540	40013	1	HOSEBARB, 3/8 MPT X 1/2 DL	*(25)	
43	86233410	81270	1	CLAMP, 3/4 DIA CUSHION .406 DIA	*(25)	
44	86270830	57023	1	NUT, 5/16-18 HEX NYLOCK SS	*(25)	
45	86010670	87029	1	WASHER, 5/16 FLAT SS	*(25)	
46	86276070	70593	1	SCR, 5/16-18 X 3/4 CARRIAGE SS	*(25)	
47	86277460	70847	1	SCR, 5/16-18 X 5/8 BSHCS SS	*(25)	

*SEE SERIAL NUMBER PAGE.

SOLUTION - DISK

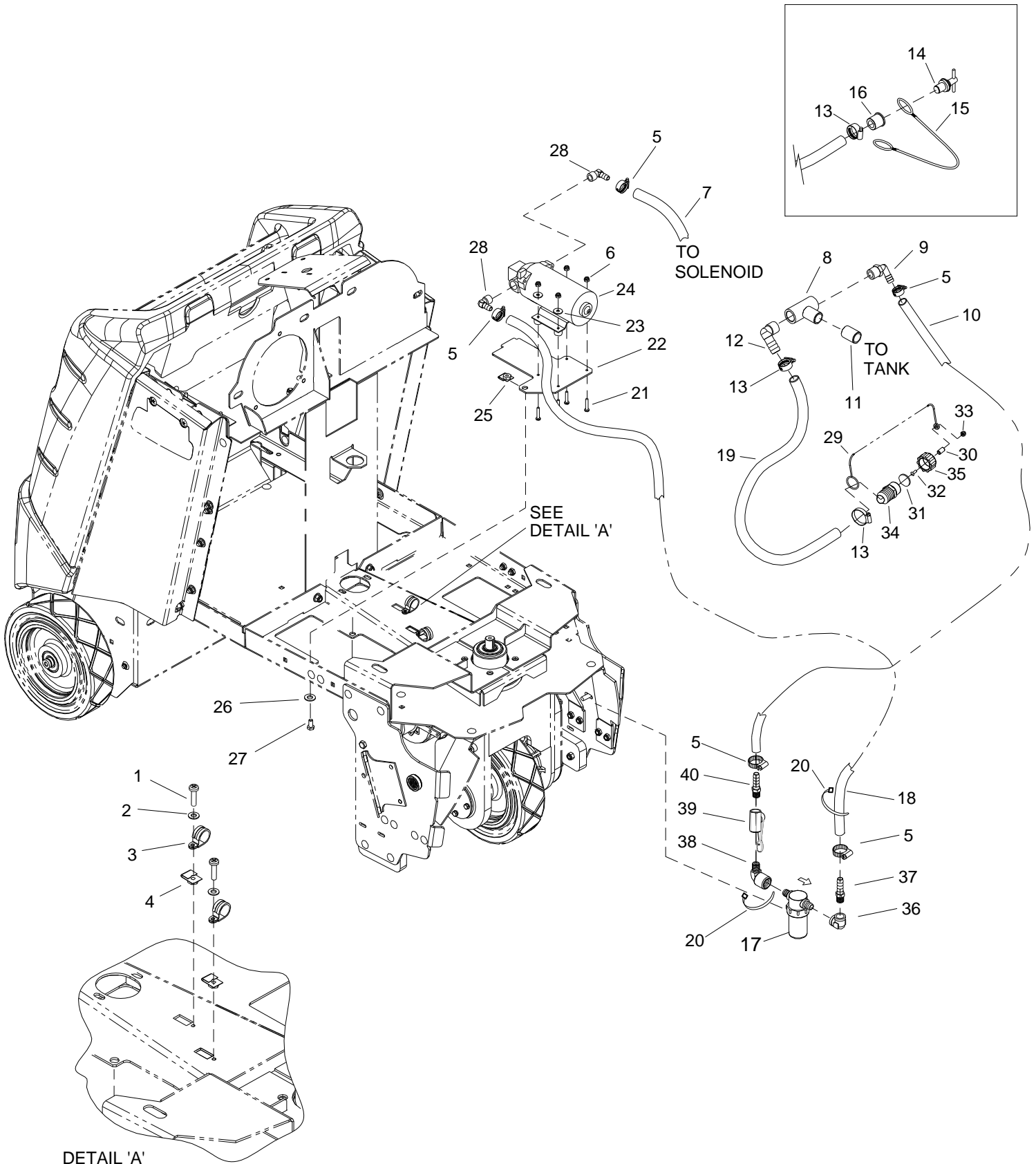

SOLUTION - DISK

REF	PART NO.	PRV NO.	QTY	DESCRIPTION	SERIAL NO. FROM	NOTES:
1	86274070	70086	2	SCR, 10-24 X 1/2 PPHMS		
2	86010650	87018	2	WASHER, #10 X 9/16 OD		
3	86233390	80887	2	CLAMP, 7/8 DIA "P" CUSHIONED		
4	86270860	57028	2	NUT, 10-24 U-TYPE SPEED		
5	86233150	20042	5	CLAMP, 3/8 HOSE (D-SLOT)		
6	86270990	57090	4	NUT, 10-32 HEX NYLOCK SS		
7	86281940	39540	1	HOSE, 1/2ID WIRE BOUND X 40"		
8	86198050	81923	1	TEE, 3/4 FPT		
9	86240390	40075	1	HOSEBARB, 3/4 MPT X 1/2 90D		
10	86282190	39616	1	HOSE, 1/2ID WIRE BOUND X 13"		
11	86247760	80960	1	NIPPLE, 3/4 CLOSE PVCE		
12	86240600	41526	1	HOSEBARB, 3/4 MPTX1, HOSE 90DEG		
13	86233110	20018	2	CLAMP, 1.00" WORM GEAR		
14	86009700	82267	1	PLUG, 5/8" DRAIN HOSE		
15	86270510	51457	1	LANYARD, .093 X 6 NYLON		WAS 78499
16	86001600	40076	1	SLEEVE, .63 ID X 1.0 OD		
17	86007940	73836	1	STRAINER, DEEP, 100 MESH		
-	86005870	59021	-	O-RING, FILTER SEAL RON-VIK		SERVICE ONLY
-	86136800	73839	-	SCREEN, 100 MESH STRAINER DEEP		SERVICE ONLY
18	86281950	39541	1	HOSE, 1/2ID WIRE BOUND X 32"		
19	86004310	39505	1	HOSE, 1.0 X 18.0 DRAIN		
20	86264920	27049	3	CABLE, TIE. 7" UL/CSA		
21	86274410	70195	4	SCR, 10-32 X 1.25 PPHMS SS		
22	86070690	140724	1	BRKT, SOLUTION PUMP		
23	86010650	87018	4	WASHER, #10 X 9/16 OD		
24	86006100	65176	1	PUMP ASM, 36V		
25	86271820	57270	1	NUT, 5/16-18 CAPTIVE "J" PLTD		
26	86279130	87083	1	WASHER, 5/16 SPLIT LOCK PLTD		
27	86276780	70728	1	SCR, 5/16-18 X 3/4 HHCS SS		
28	86197940	40027	2	HOSEBARB, 3/8MPTX1/2 90D DL		
29	86246090	51461	1	LANYARD, .093 X 6", LOOP - .26 EYE	*(11)	
30	86254320	730400	1	SPACER, .17 ID X .25 OD X 3/16 LG	*(11)	
31	86259450	87507	1	WASHER, 1.0 D X .1 THK, SEAL	*(11)	
32	86252730	70887	1	SCR, 8-32 X 1/2 BHCS SST	*(11)	
33	86248010	57312	1	NUT, 8/32 ACORN CAP, PLATED	*(11)	
34	86226950	40109	1	1" HOSE BARB X 3/4" GHT NYLON	*(11)	
35	86073960	22104	1	CAP, 3/4" GHT W/.17 HOLE	*(11)	
36	86235450	31068	1	ELBOW, 3/8 FPT PVC SCH 80	*(25)	
37	86001590	40049	1	HOSEBARB, 3/8 MPT X 1/2 NYLON	*(25)	
38	86197420	31026	1	ELBOW, 3/8 NPT STREET	*(25)	
39	86225680	84201	1	VALVE, 3/8" FPT BALL	*(25)	
40	86197540	40013	1	HOSEBARB, 3/8 MPT X 1/2 DL	*(25)	

*SEE SERIAL NUMBER PAGE.

SQUEEGEE - DISK

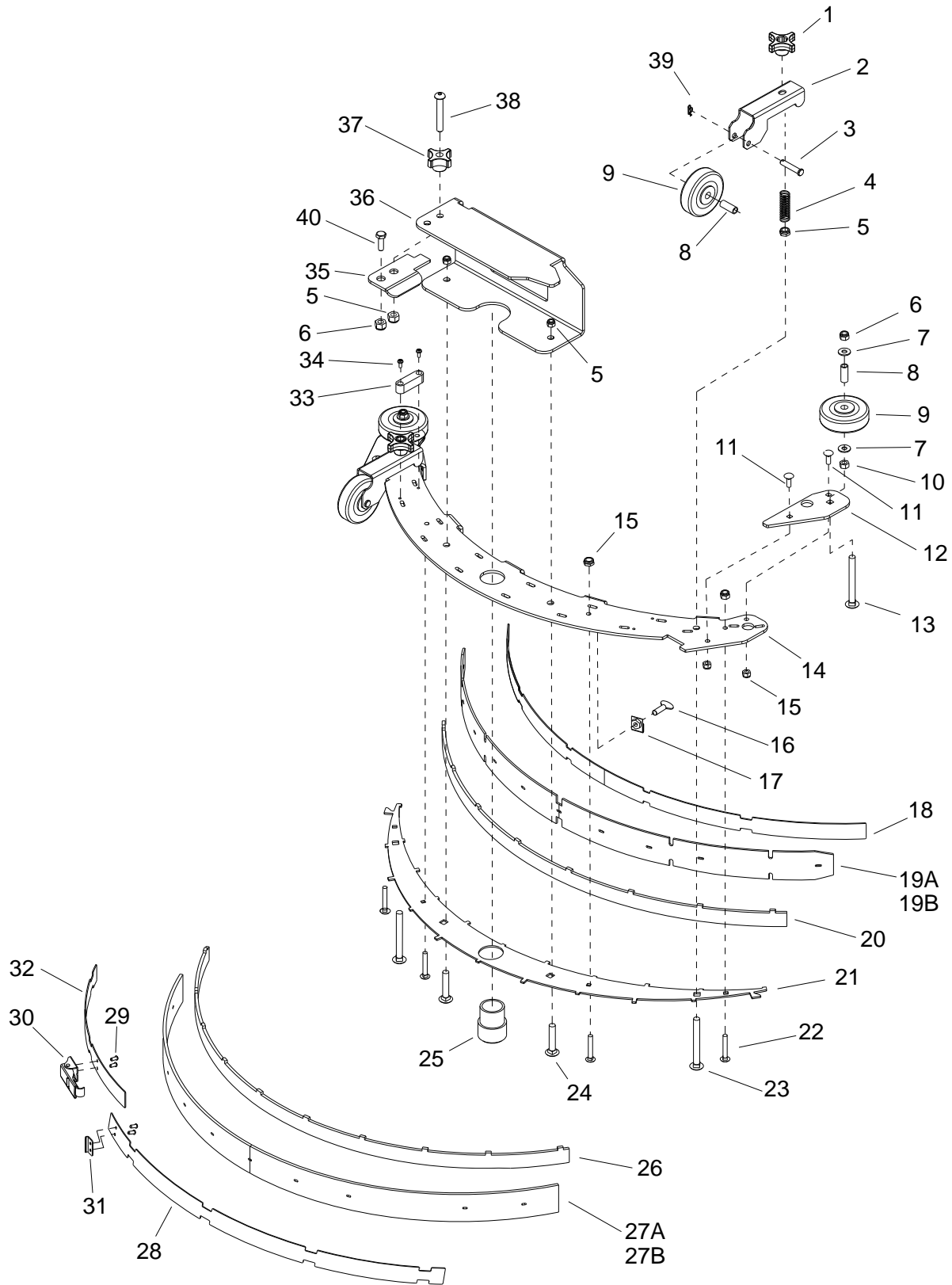

SQUEEGEE - DISK

REF	PART NO.	PRV NO.	QTY	DESCRIPTION	SERIAL NO. FROM	NOTES:
1	86004890	48095	2	KNOB, ALUM 3/8-16 NYLOCK NUT SS		
2	86070920	140759	2	BRKT, SQG WHEEL		
3	86006270	66276	2	PIN, CLEVIS 5/16 X 1.63 PLTD		
4	86007780	73576	2	SPRING, COMP .60D X 2.0L X .045 W		
5	86005630	57022	2	NUT, 3/8-16 HEX NYLOCK THIN SS		
6	86270830	57023	3	NUT, 5/16-18 HEX NYLOCK SS		
7	86010670	87029	4	WASHER, 5/16 FLAT SS		
8	86001350	140390	2	BUSHING, SPANNER .435 X 1.10		
9	86011020	89202	4	WHEEL, 3" DIA CUSHION RUBBER		
10	86005650	57031	2	NUT, 5/16-18 HEX		
11	86276950	70772	4	SCR, 1/4-20 X 3/4 CARRIAGE SS		
12	86083290	66463	2	PLATE, SQG WHEEL NMT BUMPER		
13	86276710	70717	2	SCR, 5/16-18 X 2.0 CARRIAGE SS		
14	86083250	66459	1	PLATE, SQG TOP 33"		
15	86271870	57290	4	NUT, 1/4-20 HEX NYLOCK THIN SS		
16	86007040	70680	5	SCR, 5/16-18 X 1 THUMB SS TYPE P		
17	86271820	57270	5	NUT, 5/16-18 CAPTIVE "J" PLTD		
18	86087830	140760	1	STRAP, SQUEEGEE		
19A	86001630	140764	1	BLADE, SQU, FRONT 36.7		
19B	86283540	140938	1	BLADE, SQU, FRONT 36.7 URETHANE		
20	86083270	66461	1	PLATE, SQG VERTICAL FILLER (F)		
21	86083260	66460	1	PLATE, SQG BOTTOM 33"		
22	86277000	70777	4	SCR, 1/4-20 X 1.5 CARRIAGE SS		
23	86276990	70776	2	SCR, 3/8-16 X 3.5 CARRIAGE SS		
24	86277450	70846	2	SCR, 3/8-16 X 2 LG CARRIAGE SS		
25	86008390	78493	1	TUBE ASM, SQUEEGEE VAC		
26	86083280	66462	1	PLATE, SQG VERTICAL FILLER		
27A	86001580	140763	1	BLADE, SQU, REAR 40.6 LINATEX		
27B	86283510	140935	1	BLADE, SQU, REAR 40.6 URETHANE		
28	86066440	140761	1	BAND, REAR SQUEEGEE		
29	86006400	67380	4	RIVET, 5/32 OF X 1/8 GRIP		
30	86009170	81488	1	LATCH, SQUEEGEE STRAP		
31	86009180	81489	1	STRIKER, SQUEEGEE STRAP REAR		
32	86066450	140762	1	BAND, SQG REAR RH		
33	86009910	82576	1	VIAL, LEVEL		
34	86274130	70098	2	SCR, 8-32 X 3/8 PHTC 'F' PLATD		
35	86071070	140795	1	BRKT, SQG QUICK CONNECT LOCK		
36	86071060	140794	1	BRKT, SQG QUICK CONNECT MTG		
37	86009200	81535	1	KNOB, 3/8-16 4 PRONG ALUM		
38	86277440	70845	1	SCR, 3/8-15 X 2.5 LG BSHCS SS		
39	86008660	80605	2	COTTER, 5/16 RING		
40	86277460	70847	1	SCR, 5/16-18 X 5/8 BSHCS SS		

NOTE: Complete Squeegee Assembly available, Part No. 47455

SQUEEGEE - CYLINDRICAL

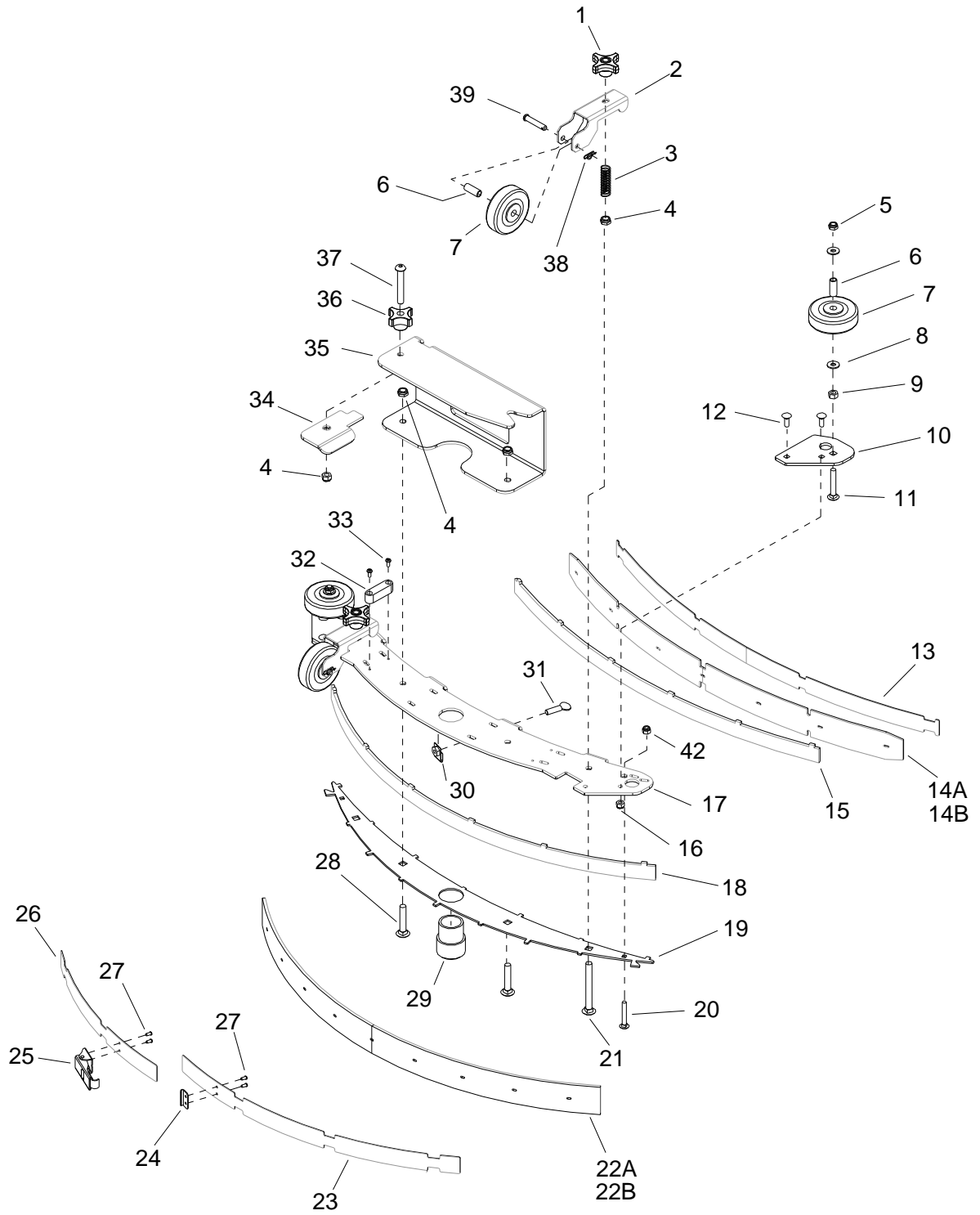

SQUEEGEE - CYLINDRICAL

REF	PART NO.	PRV NO.	QTY	DESCRIPTION	SERIAL NO. FROM	NOTES:
1	86004890	48095	2	KNOB, ALUM 3/8-16 NYLOCK NUT SS		
2	86069870	140531	2	BRKT, SQG WHEEL		
3	86007780	73576	2	SPRING, COMP .60 D X 2.0 L X .045 W		
4	86005630	57022	6	NUT, 3/8-16 HEX NYLOCK THIN SS		
5	86271840	57285	2	NUT, 5/16-18 HEX NYLOCK THIN SS		
6	86001350	140390	2	BUSHING, SPANNER .435 X 1.10		
7	86011020	89202	4	WHEEL, 3" DIA CUSHION RUBBER		
8	86010670	87029	2	WASHER, 5/16 FLAT SS		
9	86005650	57031	2	NUT, 5/16-18 HEX		
10	86083420	66822	2	PLATE, BUMPER WHEEL MOUNT		
11	86276710	70717	2	SCR, 5/16-18 X 2.0 CARRIAGE SS		
12	86276950	70772	4	SCR, 1/4-20 x 3/4 CARRIAGE SS		
13	86087850	140833	1	STRAP, SQUEEGEE		
14A	86283490	140841	1	BLADE, SQU FRONT 29.4		
14B	86283530	140937	1	BLADE, SQU FRONT 29.4 URETHANE		
15	86083470	66828	1	PLATE, SQG VERTICAL FILLER (F)		
16	86005810	57245	4	NUT, 1/4-20 HEX NYLOCK SS		
17	86071260	140830	1	BRKT, SQUEEGEE TOP PLATE		
18	86083460	66827	1	PLATE, SQG VERTICAL FILLER (R)		
19	86083430	66823	1	PLATE, SQUEEGEE BOTTOM 33 IN		
20	86277000	70777	2	SCR, 1/4-20 X 1.5 CARRIAGE SS		
21	86276990	70776	2	SCR, 3/8-16 X 3.5 CARRIAGE SS		
22A	86283500	140842	1	BLADE, SQU REAR 31.3 LINATEX		
22B	86283520	140936	1	BLADE, SQU REAR 31.3 URETHANE		
23	86066490	140834	1	BAND, REAR SQUEEGEE		
24	86009180	81489	1	STRIKER, SQUEEGEE STRAP REAR		
25	86009170	81488	1	LATCH, SQUEEGEE STRAP		
26	86066500	140835	1	BAND, REAR SQUEEGEE		
27	86006400	67380	4	RIVET, 5/32 OF X 1/8 GRIP		
28	86277450	70846	2	SCR, 3/8-16 X 3 LG CARRIAGE SS		
29	86008390	78493	1	TUBE ASM, SQUEEGEE VAC		
30	86271820	57270	4	NUT, 5/16-18 CAPTIVE "J" PLTD		
31	86007040	70680	4	SCR, 5/16-1/ X 1 THUMB SS TYPE P		
32	86009910	82576	1	VIAL, LEVEL		
33	86274130	70098	2	SCR, 8-320X 3/8 PHTC "F" PLTD		
34	86071070	140795	1	BRKT, SQG QUICK CONNECT LOCK		
35	86071190	140823	1	BRKT, SQG QUICK CONNECT MTG		
36	86009200	81535	1	KNOB, 3/8-16 4 PRONG ALUM		
37	86277440	70845	1	SCR, 3/8-16 X 2.50 LG BSHCS SS		
38	86008660	80605	2	COTTER, 5/16" RING		
39	86006270	66276	2	PIN, CLEVIS 5/16 X 1.63 PLTD		
40	86277460	70847	1	SCR, 5/16-18 x 5/8 BSHCS SS	*(5)	
41	86270830	57023	1	NUT, 5/16-18 HEX NYLOCK SS	*(5)	
42	86271870	57290	2	NUT, 1/4-20 HEX NYLOCK THIN SS		

*SEE SERIAL NUMBER PAGE.

SQUEEGEE LIFT-BASIC

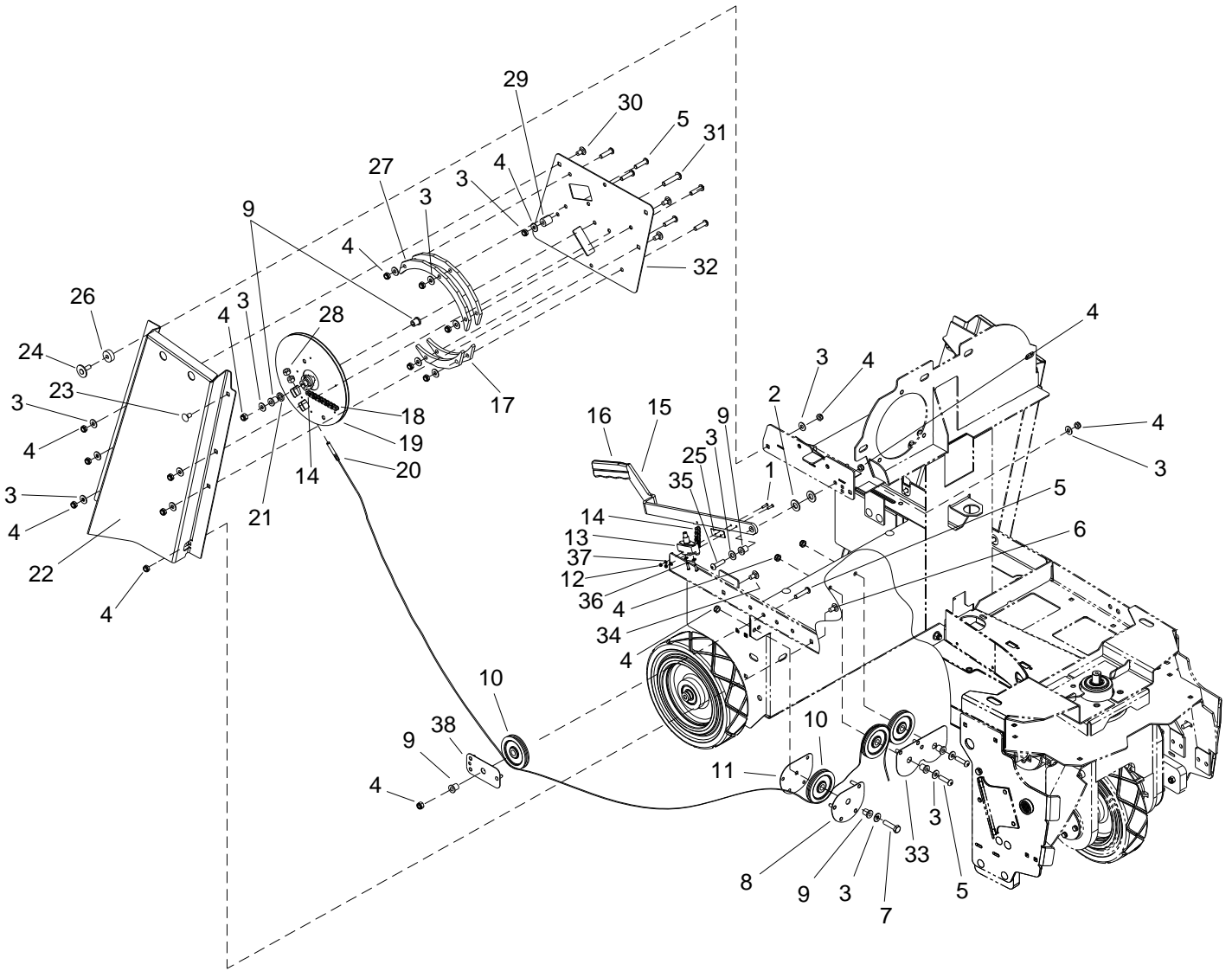

SQUEEGEE LIFT-BASIC

REF	PART NO.	PRV NO.	QTY	DESCRIPTION	SERIAL NO. FROM	NOTES:
1	86277490	70851	2	SCR, 6-32 X 1.5 PPHMS SS		
2	86259420	87232	2	WASHER, THRUST .51ID X 1 OD		
3	86010670	87029	19	WASHER, 5/16 FLAT SS		
4	86270830	57023	21	NUT, 5/16-18 HEX NYLOCK SS		
5	86276760	70724	9	SCR, 5/16-18 X 1.25 BSHCS SS		
6	86277460	70847	1	SCR, 5/16-18 X 5/8 BSHCS SS		
7	86274720	70264	1	SCR, 5/16-18 X 1.5 HHCS SS		
8	86083490	66831	1	PLATE, PULLEY MOUNT, CORNER	*(4)	
9	86231150	09151	7	BUSHING FLANGED, .314ID X .502OD		
10	86223370	66464	4	PULLEY, PLASTIC 3.0 DIA.		
11	86083500	66832	1	PLATE, PULLEY RETAINER, CORNER	*(4)	
12	86270920	57049	2	NUT, 6-32 HEX NYLOCK SS		
13	86257120	72192	1	SWITCH, DPST SNAP ACTION		
14	86226630	51010	2	LINK, #35 MASTER		
15	86076610	38319	1	HANDLE, SQUEEGEE LIFT		
16	86238360	36215	1	GRIP, 3/16 X 1.0 ORANGE		
17	86083360	66474	2	PLATE, KEEPER BOTTOM		
18	86232670	270099	1	CHAIN, #35, 3/8 PITCH X 29		
19	86073890	270096	1	CAM, SQUEEGEE LIFT		
20	86231560	270097	1	CABLE, SQUEEGEE LIFT BASIC		
21	86279350	87140	1	WASHER, WAVE 1/2ID X 3/4 X .125		
22	86091820	140807	1	BRKT, SIDE CHANNEL R		
23	86276070	70593	1	SCR, 5/16-18 X 3/4 CARRIAGE SS		
24	86066130	89501	1	ASM, HANDLE RETAINER	*(15)	
25	86295860	-	1	INSULATOR, SWITCH		
26	86254280	730331	1	SPACER, 1.00 OD X .32 ID X .375		
27	86083350	66473	2	PLATE, KEEPER TOP		
28	86270870	57029	2	NUT, 1/4-20 HEX SS		
29	86254580	80835	1	SPACER, .32ID X .71OD X .76L NYL		
30	86277410	70840	4	SCR, 5/16-18 X 5/8 CARRIAGE SS		
31	86277400	70839	1	SCR, 5/16-18 X 1.75 BSHCS SS		
32	86083340	66471	1	PLATE, CAM MOUNT		
33	86083440	66824	1	PLATE, PULLEY MOUNTING, CENTER		
34	86276070	70593	1	SCR, 5/16-18 X 3/4 CARRIAGE SS		
35	86007020	70673	1	SCR, 5/16-18 X 1.25 HHCS SS NP		
36	86278980	87014	2	WASHER, #8 INT.STAR		
37	86279450	87161	4	WASHER, #6 FLAT SAE PLTD		
38	86073600	66833	1	BRKT, PULLEY RETAINER, SINGLE	*(4)	

*SEE SERIAL NUMBER PAGE.

SQUEEGEE LIFT-DELUXE

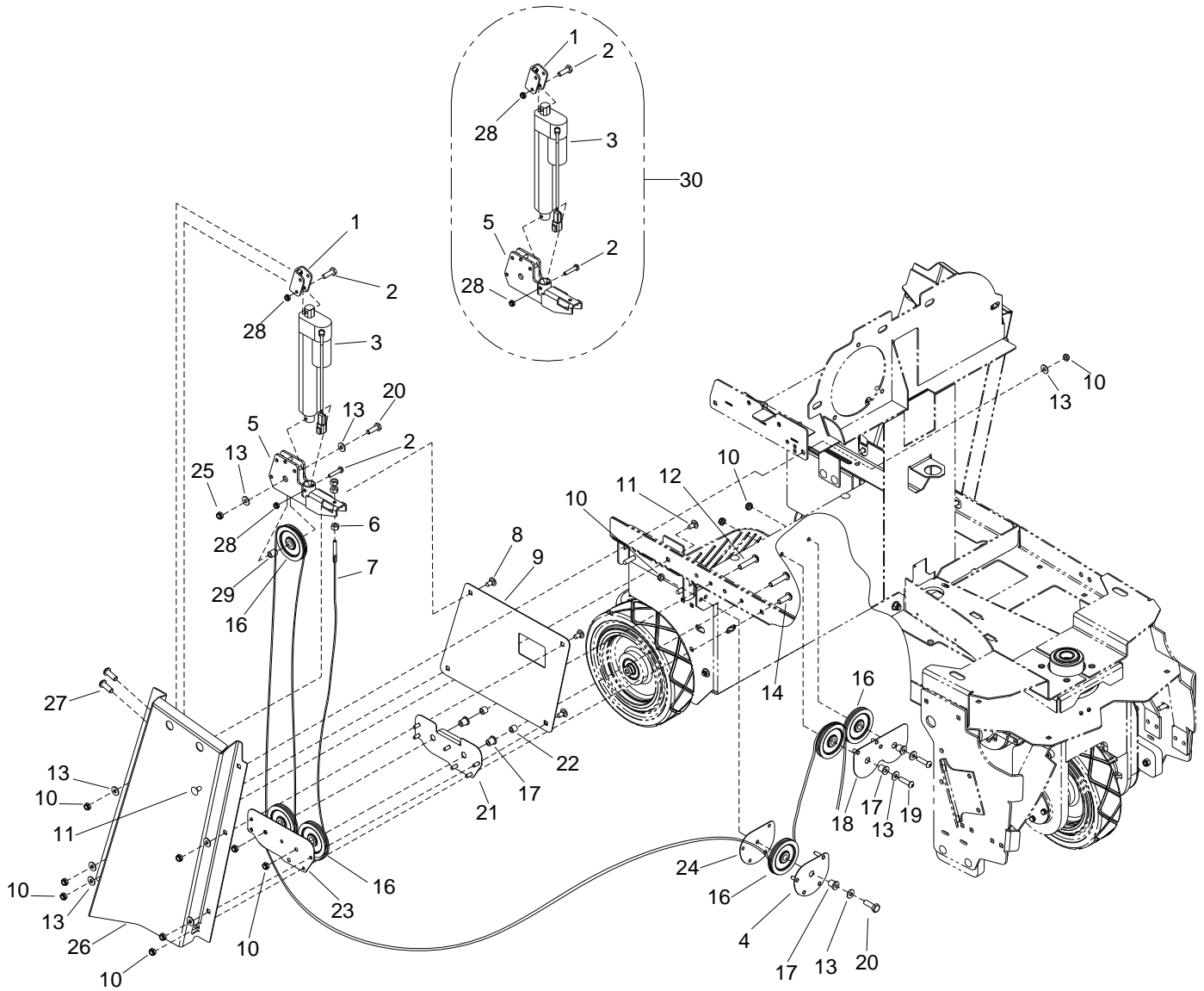

SQUEEGEE LIFT-DELUXE

REF	PART NO.	PRV NO.	QTY	DESCRIPTION	SERIAL NO. FROM	NOTES:
1	86068190	140793	1	BRACKET, ACTUATOR MOUNT		
2	86273820	70019	1	SCR, 1/4-20 X 1.25 HHCS		
3	86316550	-	1	ACTUATOR, 36VDC, 4.5" STROKE	*(32)	WAS 05254***
4	86083490	66831	1	PLATE, PULLEY MOUNT, CORNER	*(4)	
5	86068230	140840	1	BRACKET, SQG LIFT PULLEY MOUNT	*(4)	
6	86270870	57029	3	NUT, 1/4-28 HEX SS		
7	86002780	270098	1	CABLE, SQUEEGEE LIFT DELUXE		
8	86277410	70840	4	SCR, 5/16-18 X 5/8 CARRIAGE SS		
9	86075430	270700	1	COVER, SQUEEGEE LIFT		
10	86270830	57023	15	NUT, 5/16-18 HEX NYLOCK SS		
11	86276070	70593	3	SCR, 5/16-18 X 3/4 CARRIAGE SS		
12	86277400	70839	2	SCR, 5/16-8 X 1.75 BSHCS SS		
13	86010670	87029	10	WASHER, 5/16 FLAT SS		
14	86277460	70847	1	SCR, 5/16-18 X 5/8 BSHCS SS		
15	86259420	87232	1	WASHER, THRUST .51ID X 1 OD BRO		
16	86223370	66464	6	PULLEY, PLASTIC 3.0 DIA		
17	86231150	09151	5	BUSHING, FLANGE, .314ID X .502OD		
18	86083440	66824	1	PLATE, PULLEY MOUNTING, CENTER		
19	86276760	70724	2	SCR, 5/16-18 X 1.25 BSHCS SS		
20	86274720	70264	2	SCR, 5/16-18 X 1.50 HHCS SS		
21	86071300	140843	1	BRACKET, PULLEY RETAINER, DOUBLE	*(4)	
22	86224290	730008	2	SPACER, .317ID X .50D X .44 LG		
23	86071310	140844	1	BRKT, PULLEY RETAINER, DOUBLE	*(4)	
24	86083500	66832	1	PLATE, PULLEY RETAINER, CORNER	*(4)	
25	86271840	57285	1	NUT, 5/16-18 HEX NYLOCK THIN SS		
26	86074160	270101	1	CHANNEL, RIGHT DELUXE		
27	86277480	70850	2	SCR, 5/16-18 X 1/2 PTHMS SS		
28	86271870	57290	2	NUT, 1/4-20 HEX NYLOCK THIN SS		
29	86228880	09132	1	BEARING, .314 ID X .503 OD X 1		
30	86326650	-	-	ASM, ACTUATOR AND BRACKETS		***

*SEE SERIAL NUMBER PAGE.

**CALL MANUFACTURER FOR SERIAL NUMBER

*** FOR REPLACEMENT OF 05254

SQUEEGEE SWING

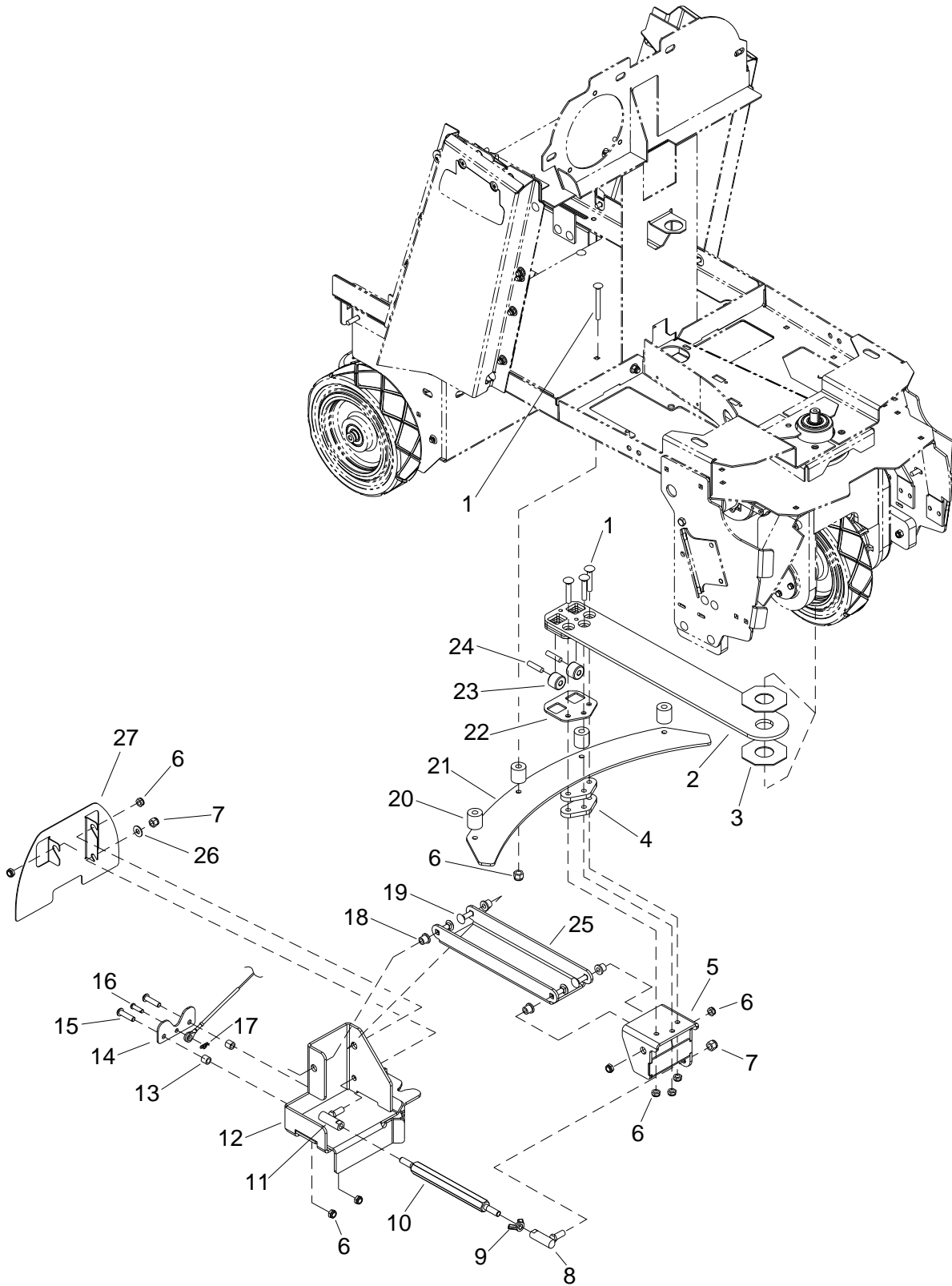

SQUEEGEE SWING

REF	PART NO.	PRV NO.	QTY	DESCRIPTION	SERIAL NO. FROM	NOTES:
1	86276690	70715	7	SCR, 5/16-18 X 1.75 CARR SS		
2	86091530	140787	1	BRACKET, SQUEEGEE SIDE PIVOT		
3	86090300	87247	2	WASHER, 1.25 ID X .075 OCTAGON		
4	86083370	66475	2	PLATE, SQG SWING SPACER		
5	86091540	140800	1	BRACKET, H PIVOT MOUNT		
6	86270830	57023	9	NUT, 5/16-18 HEX NYLOCK SS		
7	86271530	57216	2	NUT, 3/8-24 HEX NYLOCK		
8	86008810	80697	1	BALL JOINT ASY, 3/8-24 RH		
9	86271980	57303	1	NUT, 3/8-24 WING SS		
10	86223590	67510	1	ROD, CAMBER ADJUST		
11	86001320	140353	1	BALL JOINT ASSY, 3/8-24 LH		
12	86091810	140798	1	BRKT, SQG QUICK CONNECT		
13	86224290	730008	2	SPACER, .317ID X .500 X .44LG		
14	86083400	66479	1	PLATE, CABLE RETAINING		
15	86276760	70724	2	SCR, 5/16-18 X 1.25 BSHCS SS		
16	86272630	80771	1	PIN, CLEVIS 1/4 X .88 PLTD		
17	86008650	80604	1	COTTER, 1/4 RING		
18	86228840	09124	4	BEARING, FLANGED .314 ID X .502 OD		
19	86277030	70780	4	SCR, 5/16-18 X 1.25 CARRIAGE SS		
20	86224380	730336	4	SPACER, 1 OD X .343 ID X 1.063		
21	86083150	66446	2	PLATE, SQUEEGEE SWING		
22	86083310	66468	1	PLATE, WHEEL RETAINER		
23	86226030	89268	2	WHEEL, 1.000 OD X .323 ID X .750 SS		
24	86222580	66466	2	PIN, .312 DIA X 1.250 LG SS		
25	86070820	140740	2	BRKT, SQUEEGEE SWING HORIZ		
26	86278910	-	1	WASHER, 3/8 ID X 7/8 OD SS	*(33)	
27	86326670	-	1	PLATE, CABLE GUARD	*(33)	

*SEE SERIAL NUMBER PAGE

SQUEEGEE LIFT - CYLINDRICAL

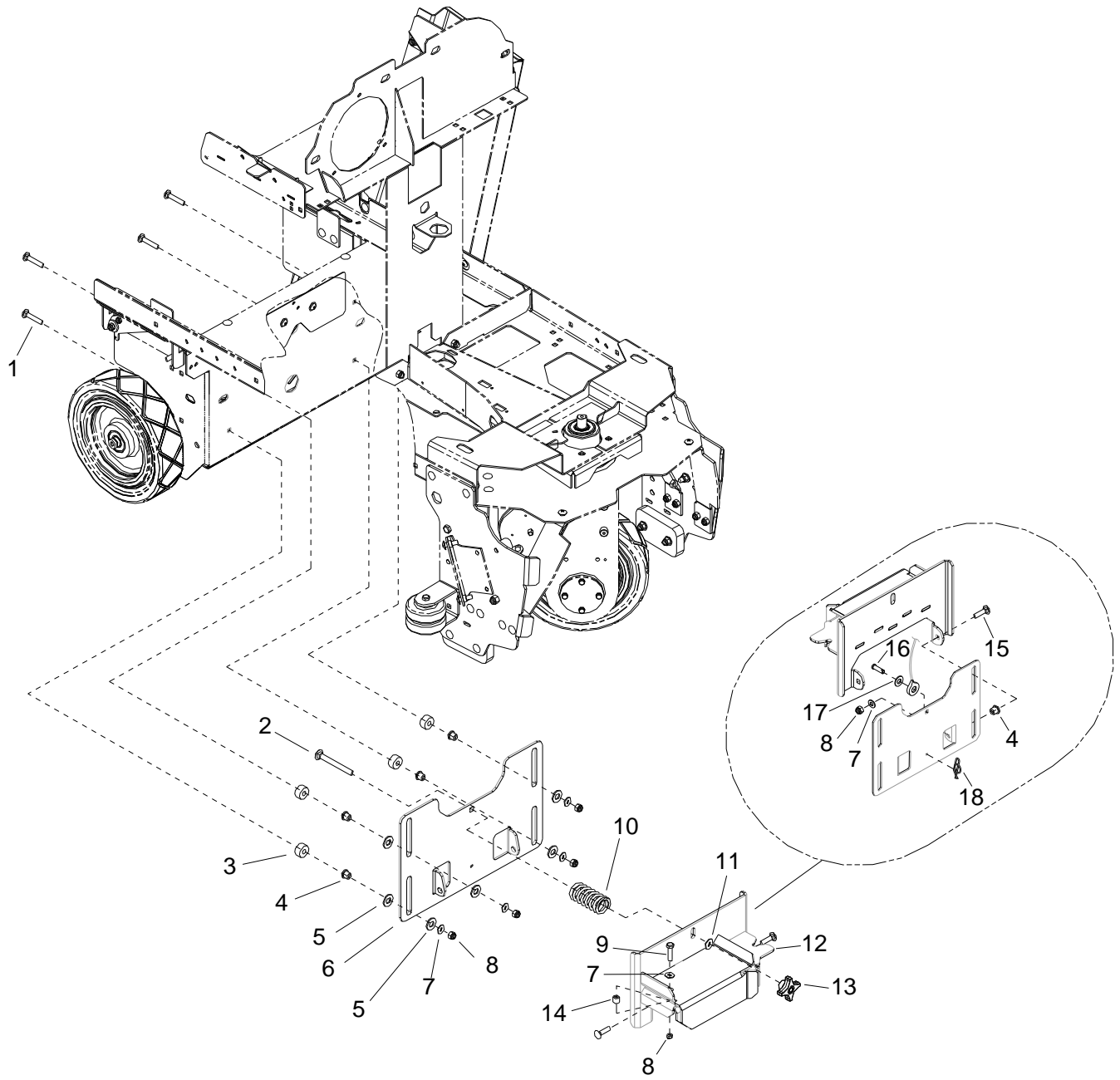

SQUEEGEE LIFT - CYLINDRICAL

REF	PART NO.	PRV NO.	QTY	DESCRIPTION	SERIAL NO. FROM	NOTES:
1	86276690	70715	4	SCR, 5/16-18 X 1.75 CARR SS		
2	86276990	70776	1	SCR, 3/8-16 X 3.5 CARRIAGE SS		
3	86224370	730335	4	SPACER, 1 OD X .391 ID X .500		
4	86228840	09124	6	BEARING, FLANGED .314 ID X .502 OD		
5	86259420	87232	8	WASHER, THRUST .51 ID X 1 OD BRO		
6	86071160	140819	1	BRKT, SQG MOUNT VERTICAL		
7	86010670	87029	7	WASHER, 5/16 FLAT SS		
8	86270830	57023	7	NUT, 5/16-18 HEX NYLOCK SS		
9	86007020	70673	1	SCR, 5/16-18 X 1.25 HHCS SS NP		
10	86007270	730006	1	SPRING, COMP 1.10 OD X 2.0 L X .148 W		
11	86278910	87003	1	WASHER, 3/8 ID X 7/8 OD SS		
12	86094270	730344	1	SQG TRACK WHEEL		
13	86004890	48095	1	KNOB, ALUM 3/8-16 NYLOCK NUT SS		
14	86224290	730008	1	SPACER, .317 ID X .50 D X .44 LG		
15	86277030	70780	2	SCR, 5/16-18 X 1.25 CARRIAGE SS		
16	86009560	82053	1	PIN, CLEVIS 1/4 X .63 PLTD		
17	86010630	87013	1	WASHER, 1/4 ID X 5/8 OD SS		
18	86008650	80604	1	COTTER, 1/4" RING		

SQUEEGEE LIFT - CYLINDRICAL

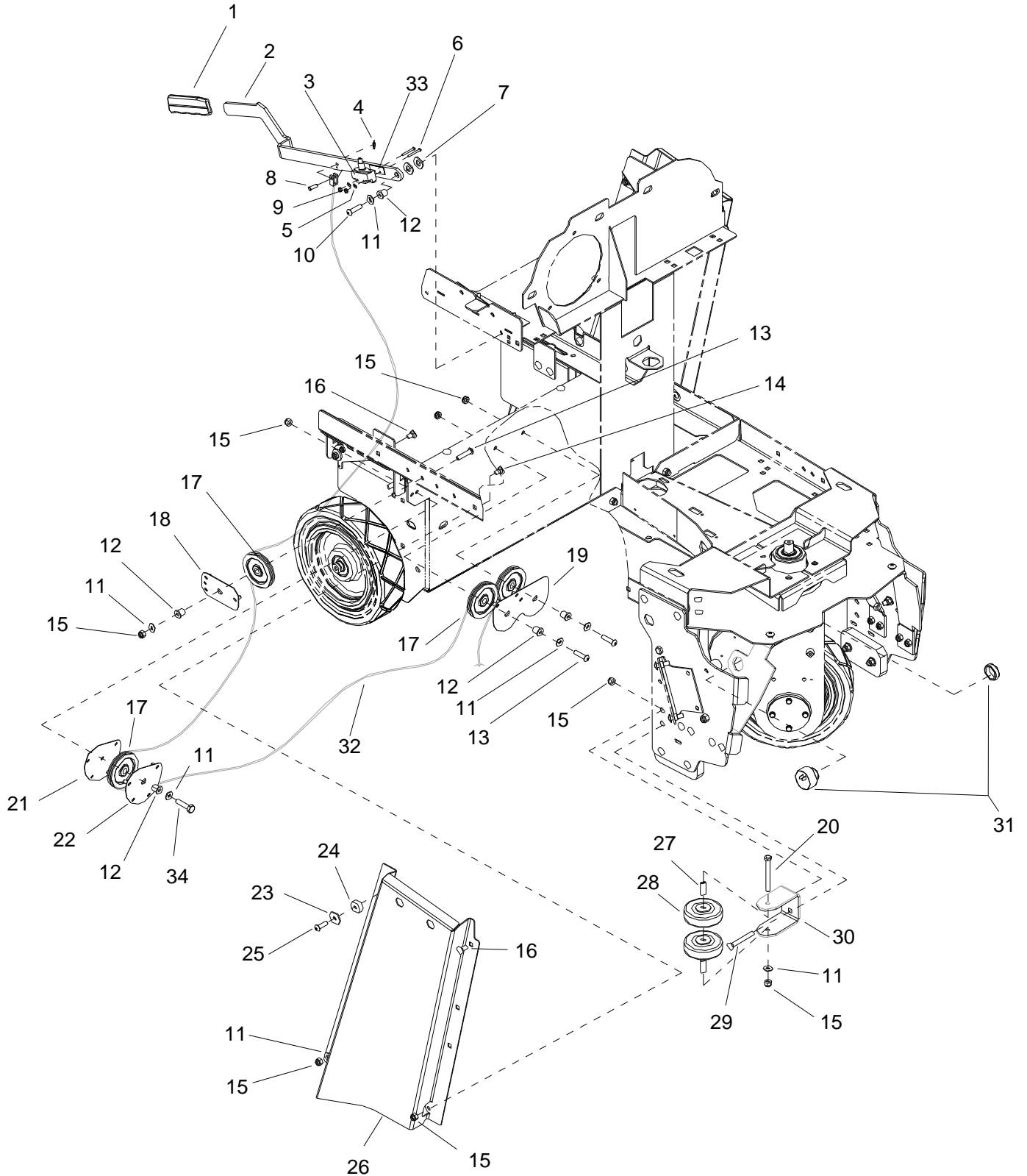

SQUEEGEE LIFT - CYLINDRICAL

REF	PART NO.	PRV NO.	QTY	DESCRIPTION	SERIAL NO. FROM	NOTES:
1	86238360	36215	1	GRIP, 3/16 X 1.0 ORANGE		
2	86076610	38319	1	HANDLE, SQUEEGEE LIFT		
3	86257120	72192	1	SWITCH, DPST SNAP ACTION		
4	86008650	80604	1	COTTER, 1/4" RING		
5	86279450	87161	2	WASHER, #6 FLAT SAE PLTD		
6	86275550	70500	2	SCR, #6-32 X 1.25 PPHMS		
7	86259420	87232	2	WASHER, THRUST .51 ID X 1 OD BRO		
8	86009560	82053	1	PIN, CLEVIS 1/4 X .63 PLTD		
9	86270920	57049	2	NUT, 6-32 HEX NYLOCK SS		
10	86007020	70673	1	SCR, 5/16-18 X 1.25 HHCS SS NP		
11	86010670	87029	8	WASHER, 5/16 FLAT SS		
12	86231150	09151	5	BUSHING, FLANGE, .314 ID X .502 OD		
13	86276760	70724	3	SCR, 5/16-18 X 1.25 BSHCS SS		
14	86277460	70847	1	SCR, 5/16-18 X 5/8 BSHCS SS		
15	86270830	57023	12	NUT, 5/16-18 HEX NYLOCK SS		
16	86276070	70593	2	SCR, 5/16-18 X 3/4 CARRIAGE SS		
17	86223370	66464	4	PULLEY, PLASTIC 3.0 DIA		
18	86073600	66833	1	BRKT, PULLEY RETAINER, SINGLE		
19	86083440	66824	1	PLATE, PULLEY MOUNTING, CENTER		
20	86276910	70754	2	SCR, 5/16-18 X 3 HHCS SS NP		
21	86083500	66832	1	PLATE, PULLEY RETAINER, CORNER		
22	86083490	66831	1	PLATE, PULLEY MOUNT, CORNER		
23	86279630	87212	1	WASHER, .344 ID X .13 OD X .09 T PLTD		
24	86254280	730331	1	SCR, 8-32 X 1/4 SPHMS BLK NYL		
25	86006930	70514	1	SCR, 5/16-18 X 1.00 BSHCS SS		
26	86091820	140807	1	BRKT, SIDE CHANNEL R		
27	86001350	140390	4	BUSHING, SPANNER .435 X 1.10		
28	86011020	89202	4	WHEEL, 3" DIA CUSHION RUBBER		
29	86277130	70795	4	SCR, 5/16-18 X 1.00 CARRIAGE SS		
30	86071290	140837	2	BRKT, SIDE WHEEL MOUNT		
31	86239720	41520	1	HORN, 108 DB MINIATURE PIEZO		
32	86231570	270105	1	CABLE, SQG LIFT, SCRUBPLUS		
33	86295860	-	1	INSULATOR, SWITCH	*(23)	
34	86274720	70264	1	SCR, 5/16-18 X 1.50 HHCS SS		

*SEE SERIAL NUMBER PAGE.

STEERING

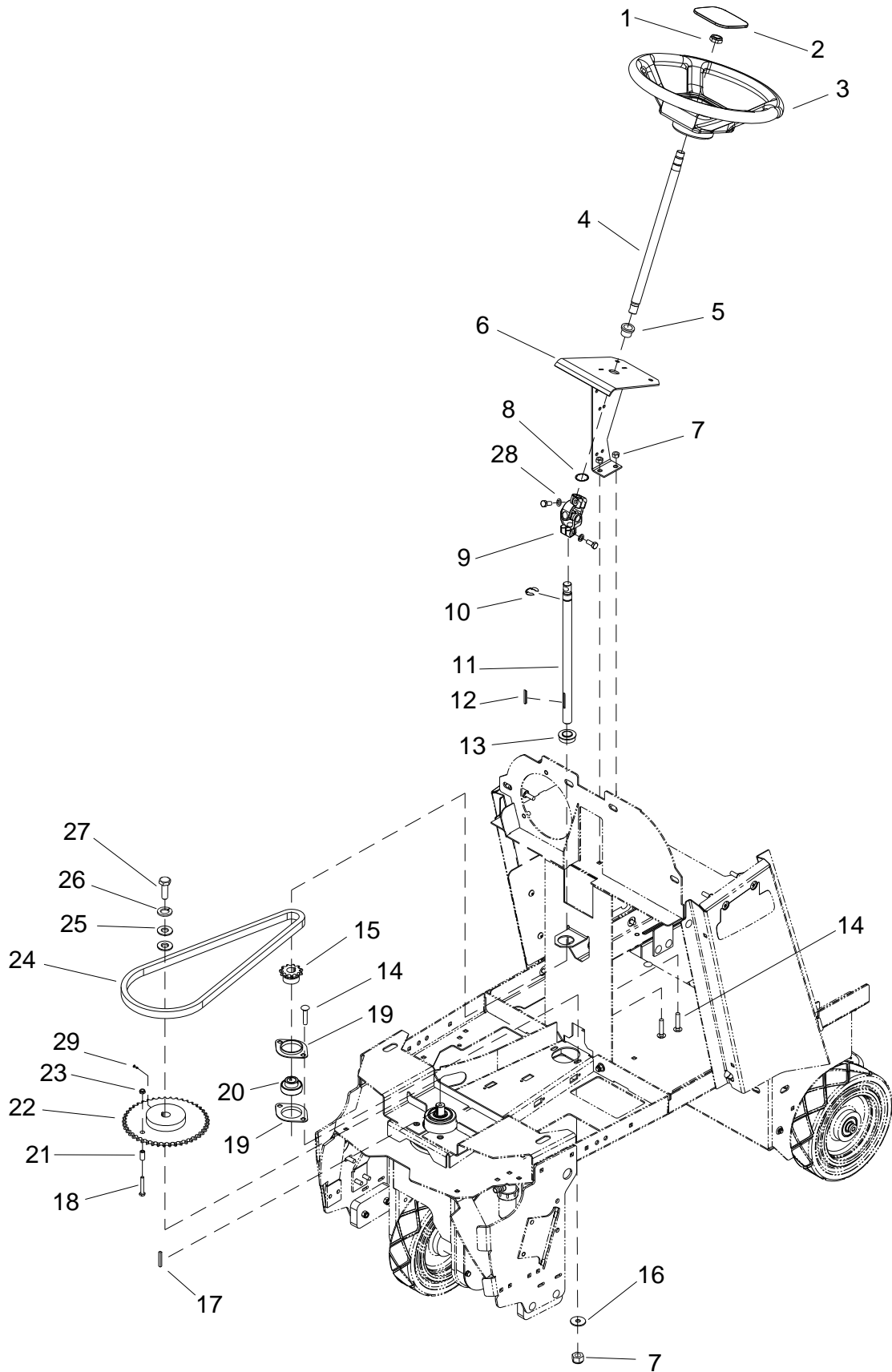

STEERING

REF	PART NO.	PRV NO.	QTY	DESCRIPTION	SERIAL NO. FROM	NOTES:
1	86271610	57228	1	NUT, 5/8-16 HEX NYLOCK THN		
2	86234810	27945	1	COVER, STEERING WHEEL		
3	86259610	730117	1	WHEEL, STEERING 40 SPLINE HUB		
4	86224050	730318	1	SHAFT, UPPER STEERING		
5	86228790	09111	1	BEARING, FLANGE .88ODX.75IDX.75		
6	86091740	140720	1	BRKT, UPPER STEERING		
7	86270830	57023	4	NUT, 5/16-18 HEX NYLOCK SS		
8	86005610	57016	1	NUT, 7/8 DIA PUSHLOCK		
9	86219600	45012	1	JOINT, UNIVERSAL FEMALE		
10	86272900	67416	1	RING, 3/4" KLIP		
11	86224060	730319	1	SHAFT, LOWER STEERING		
12	86219650	48110	1	KEY, 5MM SQ X 39MM L		
13	86228670	09072	1	BEARING, 3/4" BORE FLANGED		
14	86276070	70593	4	SCR, 5/16-18 X 3/4 CARRIAGE SS		
15	86224800	730315	1	SPROCKET, STEERING SHAFT		
16	86010670	87029	2	WASHER, 5/16 FLAT SS		
17	86135970	48045	1	KEY, 3/16 SQ X 5/8 LONG		
18	86275190	70377	1	SCR, 3/8-16 X 1.25 HHCS SS		
19	86008610	80595	2	FLANGE, BEARING PRESS STEEL		
20	86001030	09148	1	BEARING, BALL 3/4 BORE SPHERED		
21	86224320	730221	1	SPACER, .63 OD X .385ID X .64L		
22	86224810	730316	1	SPROCKET, DRIVE WHEEL STEERING		
23	86005630	57022	1	NUT, 3/8-16 HEX NYLOCK THIN SS		
24	86002750	270088	1	CHAIN, ISO 08B, 12.7MM PITCH		
25	86278940	87008	2	WASHER, 1/4 ID X 1-1/4OD		
26	86010780	87162	1	WASHER, 1/4 SPLIT LOCK PLTD		
27	86274330	70175	1	SCR, M6 X 20HHMS PLTD		
28	86279130	87083	2	WASHER, 5/16 SPLIT LOCK		
29	86253200	70806	1	SET SCR, M6 X 25 NP		SERVICE ONLY
-	86232780	279001	-	CHAIN, MASTERLINK 12.7MM		SERVICE ONLY

TANK

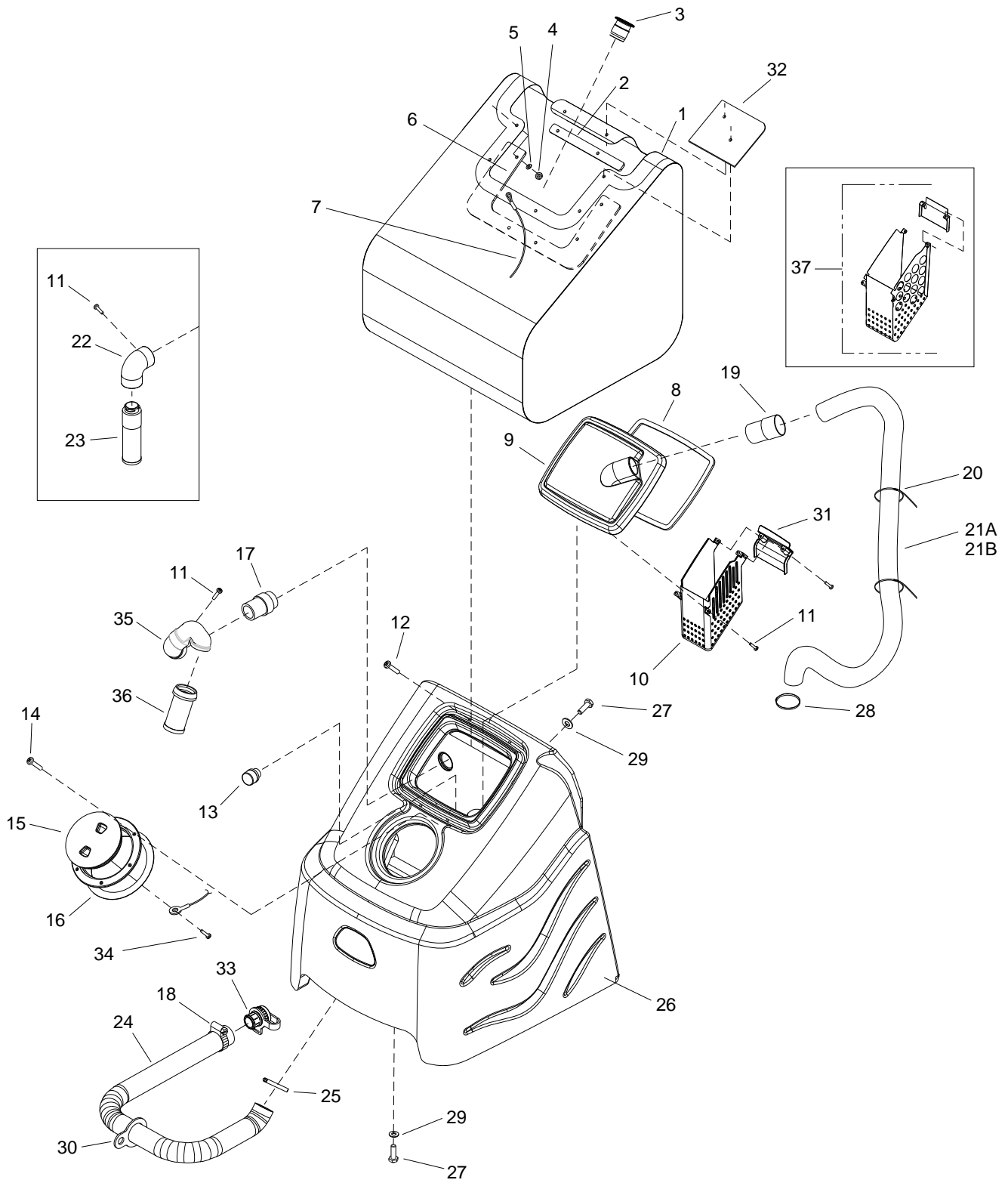

TANK

REF	PART NO.	PRV NO.	QTY	DESCRIPTION	SERIAL NO. FROM	NOTES:
1	86001510	140712	1	BAG, INNER TANK		
2	86006470	67513	1	RETAINER, BACK BAG	**	
3	86221900	54198	1	MANDREL, BAG		
4	86271940	57299	8	NUT, 1/4-20 ACORN SS		
5	86010630	87013	8	WASHER, 1/4-20 X 5/8 OD SS		
6	86006480	67514	1	RETAINER, MAIN BAG	**	
7	86246080	51368	1	LANYARD, 18.0 W/LOOP & EYE		
8	86004010	35274	1	GASKET, DOME EDGE		
9	86003350	28063	1	DOME, COVER, 10X13		
10	86310190	-	1	BASKET, STRAINER, DOME	*(31)	
11	86006860	70403	5	SCR, #10X1/2 PPHST TYPE B		
12	86276840	70744	8	SCR, 1/4-20X1 PFH BLK SS		
13	86256100	730333	1	STRAINER, 3/4-MNPT, 12 MESH		
14	86275800	70546	6	SCR, 8 X 3/4 PFHT/S BLK ZINC		
15	86002620	260-64A	1	ACCESS COVER CLEAR 6" W/RIM		
16	86004000	35255	1	GASKET, TANK LID		
17	86033570	78934	1	TUBE ASM		
18	86072390	20063	1	CLAMP, 1.75" WORM GEAR X .312		
19	86003010	27759	1	CUFF, HOSE 1.5" BLK A 2161		
20	86264950	27746	3	CABLE TIE, .19W X 11.5L BLK		
21A	86305960	-	1	HOSE ASM, 1.5 BLK PVC VAC X 67		DISK
21B	86004380	39550	1	HOSE ASM, 1.5 BLK VAC X 50		SCRUB PLUS
22	86197870	31101	1	ELBOW, 1.5 FS X FS 90 DEG		
23	86003680	34380	1	FLOAT, SHUT-OFF		
24	86311740	-	1	HOSE, 2.0 X 37.0, DRAIN	**	
-	86004430	39707	1	HOSE ASM, 2 X 37.0 DRAIN, ASM		HOSE & CAP
25	86002380	20046	1	CLAMP, 2.25" WORM GEAR		
26	86032870	75455	1	TANK		
27	86006760	70305	6	SCR, 5/16-18 x 3/4 HHCS GR5 PLTD		
28	86177050	03-000176	1	CLAMP, HOSE #20	*(14)	
29	86279630	87212	6	WASHER, .344 ID X 1.13 OD X .09T PLT		
30	86257570	51407	1	TETHER, DRAIN HOSE, 1.5		
31	86310180	-	1	PLATE, STRAINER BASKET	*(31)	
32	86003710	34447	1	FLAP, TANK DEBRIS	*(7)	
33	86004440	39717	1	CAP, DRAIN HOSE		
34	86277560	70866	1	SCR, #6 X 1/2 SHT MTL SS		
35	86025200	31377	1	ELBOW ASM, FLOAT	*(19)	
36	86199840	090-12A	1	FLOAT SCREEN CAGE ASSY	*(19)	
37	98406760	-	1	KIT, DOME BASKET		

* SEE SERIAL NUMBER PAGE.

** CALL MANUFACTURER FOR SERIAL NUMBER

VACUUM

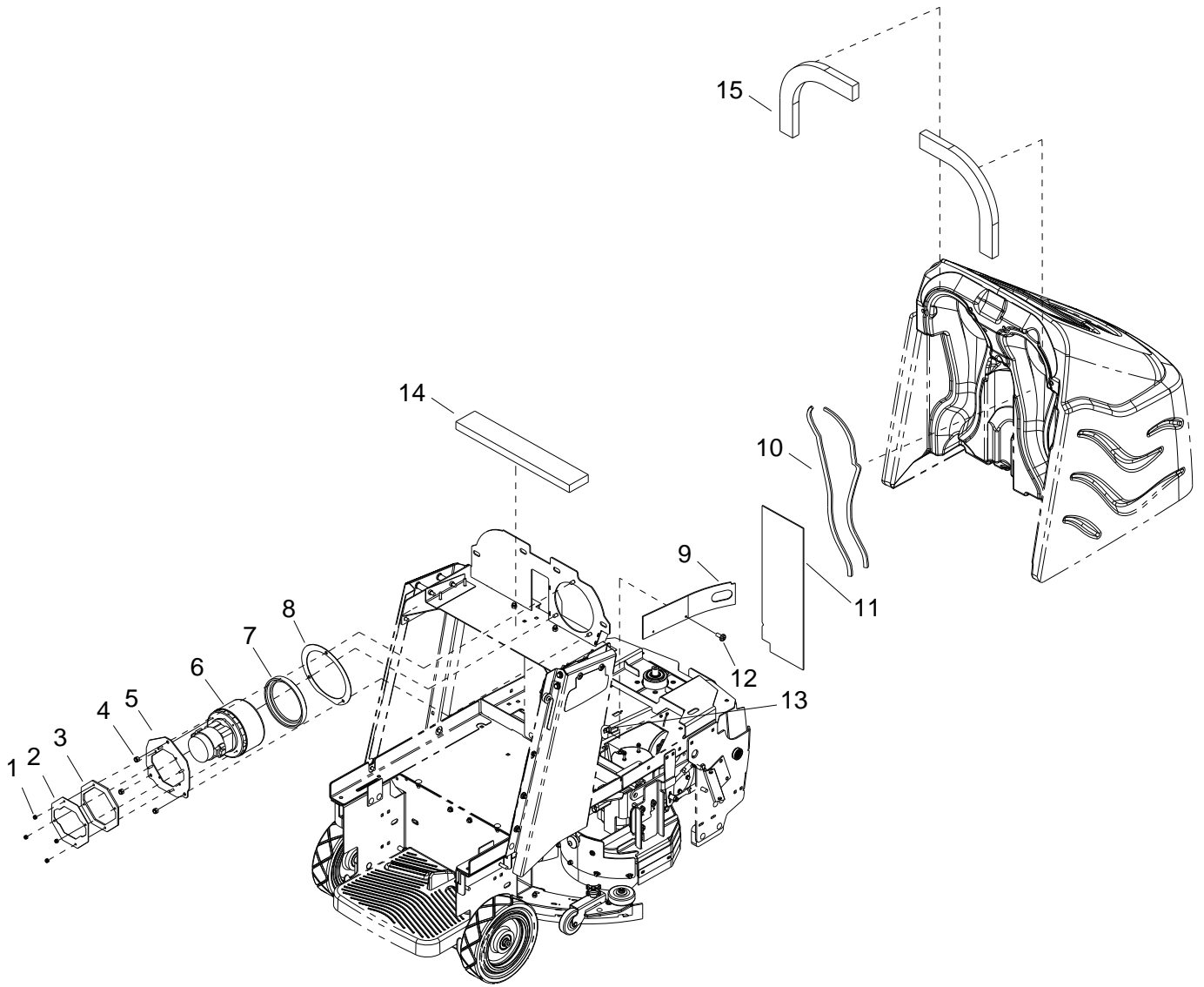

VACUUM

REF	PART NO.	PRV NO.	QTY	DESCRIPTION	SERIAL NO. FROM	NOTES:
1	86270990	57090	4	NUT, 10-32 HEX NYLOCK SS		
2	86083030	66430	1	PLATE, VAC MOTOR ADAPT		
3	86083010	66428	1	PLATE, VAC SPACER		
4	86270830	57023	3	NUT, 5/16-18 HEX NYLOCK SS		
5	86083020	66429	1	PLATE, VAC MOUNTING		
6	86005500	53809	1	VAC MOTOR 36VDC 3 STG		
-	86135310	140686	-	BRUSH SET, 24/36V VAC WINDSOR		SERVICE ONLY
7	86237880	35276	1	GASKET, 5.7 VAC MOTOR		
8	86237890	35277	1	GASKET, VAC MOUNT		
9	86078650	36241	1	GUARD, CHAIN RT		
10	86238040	36243	2	GASKET, 1/4 T X 3/4 W X 24 L		
11	86064740	270100	1	VAC CHANNEL COVER		
12	86274070	70086	2	SCR, 10-24 X 1/2 PPHMS		
13	86270860	57028	2	NUT, 10-24 U-TYPE SPEED		
14	86236530	34436	1	FOAM, POLYESTER, 1X3X18	*(3)	
15	86236540	34437	2	FOAM, POLY, 1X2 CURVED W/ADH	*(3)	

*SEE SERIAL NUMBER PAGE.

WHEEL-FRONT DRIVE, CHAIN

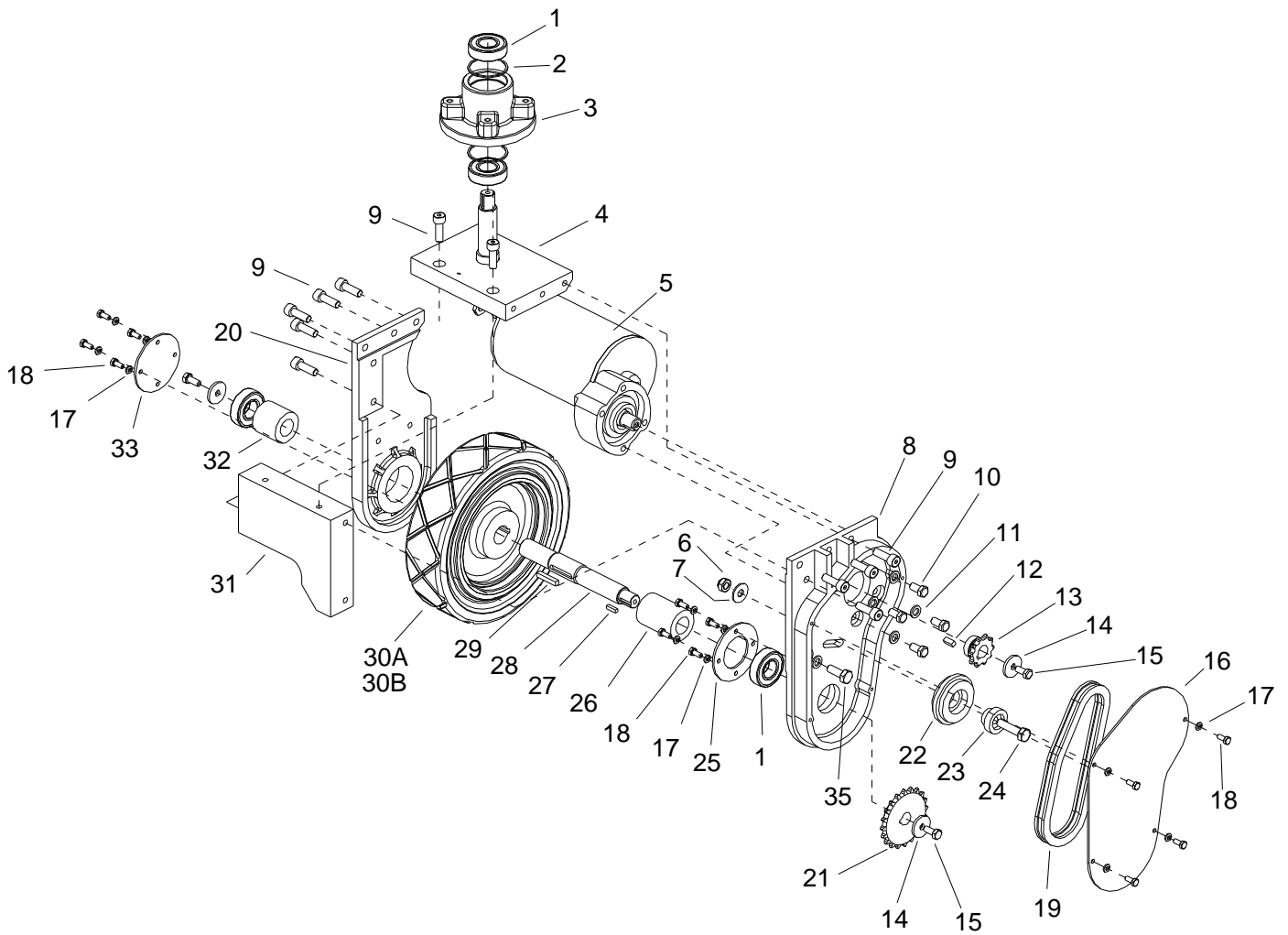

WHEEL-FRONT DRIVE, CHAIN

REF	PART NO.	PRV NO.	QTY	DESCRIPTION	SERIAL NO. FROM	NOTES:
1	86223980	09134	4	SEALED BALL BRNG, 25MM X 52MM		
2	86223480	67450	2	RING, 52MM INTERNAL SNAP		
3	86219420	41510	1	STEERING, HUB		
4	86224040	730306	1	SHAFT, ASM, DRIVE PIVOT		
5	86005510	53810	1	MOTOR, 36V 180RPM GEAR		
-	86216210	53820	-	BRUSH SET MOTOR 53810		
-	86227440	05261	-	ARMATURE 53810 MOTOR		
6	86136360	57275	1	NUT, M10X1.5 HEX NYLOCK PLTD		
7	86010720	87086	1	WASHER, M10 X 30 PLTD		
8	86222730	620038	1	PLATE, DRIVE WHEEL YOKE		
9	86318830	-	11	SCR, M10 X 30 SHCS		
10	86275640	70515	4	SCR, 3/8-24 X 3/4 HHCS GR5 PLTD		
11	86279700	87244	5	WASHER, M10 X 18 FLAT		
12	86219620	48106	1	KEY, 1/4 SQ. X .63		
13	86007620	730310	1	SPROCKET, MOTOR SHAFT		
14	86279710	87245	3	WASHER, M8 (2 THK X 26 OD)		
15	86136640	70262	2	SCR, M8-1.25 X 20HHMS PLTD		
16	86222710	620036	1	PLATE, CHAIN COVER		
17	86279690	87243	12	WASHER, M6 SPLIT LOCK BLK		
18	86277340	70830	12	SCR, M6 X 15 HHCS BLK		
19	86002730	270085	1	CHAIN, ISO 08B 12.7MM PITCH/LINK		
-	86232770	279000	-	CHAIN, OFF-SET LINK 12.7MM		SERVICE ONLY
-	86232780	279001	-	CHAIN, MASTERLINK 12.7MM		SERVICE ONLY
20	86222760	620041	1	PLATE, DRIVE YOKE RH		
21	86007630	730311	1	SPROCKET, DRIVE WHEEL		
22	86002710	270076	1	CHAIN TENSIONER		
23	86224270	730293	1	SLEEVE, CHAIN TENSIONER		
24	86277330	70829	1	SCR, M10 X 45 HHCS		
25	86222720	620037	1	PLATE, BEARING RETAINER		
26	86224330	730294	1	SPACER, 25.5ID X 45OD X 65L		
27	86219630	48107	1	KEY, 3/16 SQ X .67		
28	86000850	05231	1	AXLE, DRIVE		
29	86219640	48108	1	KEY, 1/4 SQ X 1.5		
30A	86011120	89262	1	WHEEL, 10X2.5X1.06 W/KEYWY		
30B	86259920	89273	1	WHEEL, 10X2.5 W/KEYWY GRY		OPTIONAL
31	86222750	620040	1	PLATE, DRIVE YOKE FRONT		
32	86224340	730295	1	SPACER, 25.5ID X 45OD X 43L		
33	86222770	620042	1	PLATE, BEARING COVER		
34	86217720	29269	-	DRIVE ASM, MOTOR		COMPLETE
35	86277320	70828	1	SCR, M10 X 30 HHCS		

WHEEL-FRONT DRIVE, GEAR

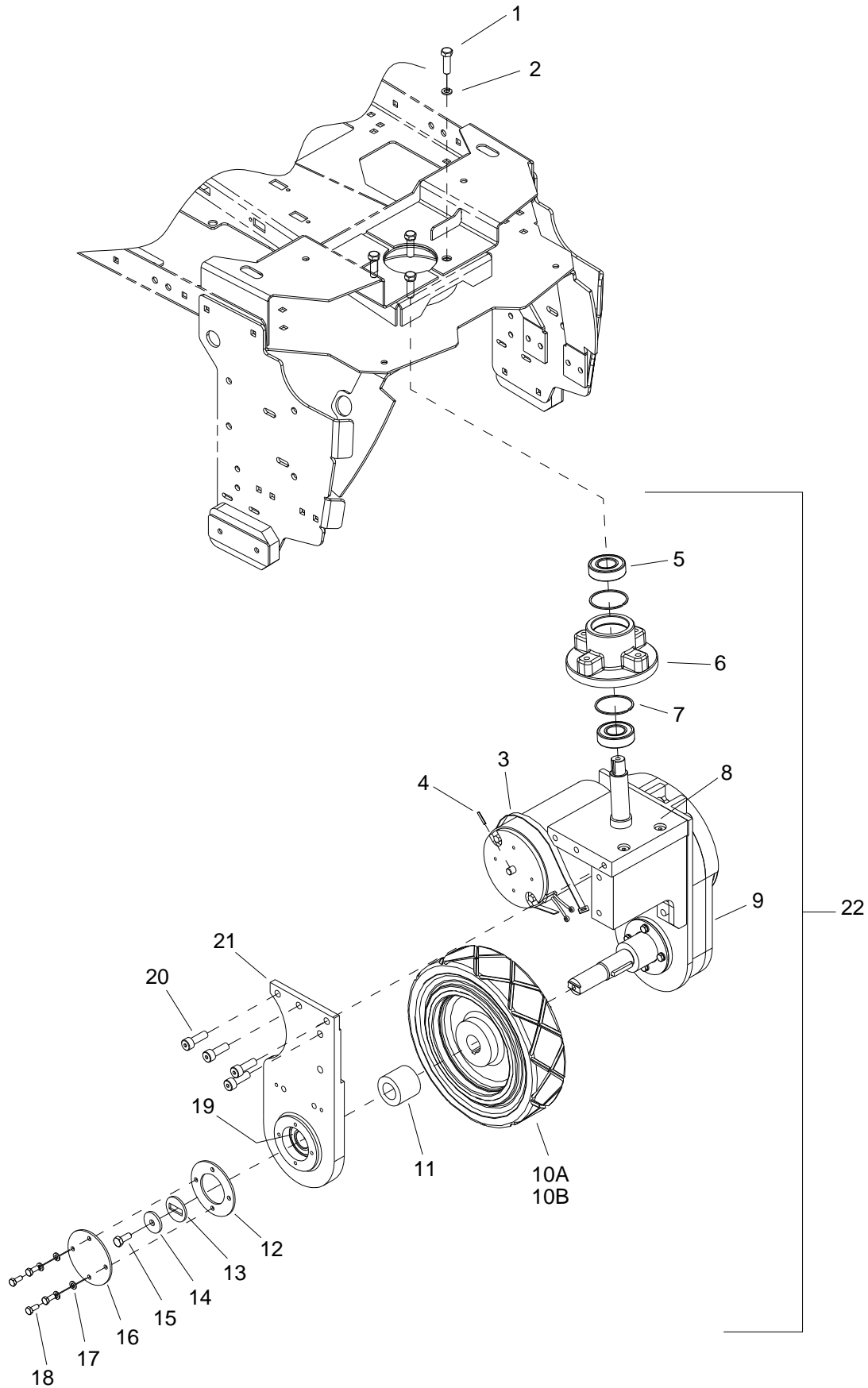

WHEEL-FRONT DRIVE, GEAR

REF	PART NO.	PRV NO.	QTY	DESCRIPTION	SERIAL NO. FROM	NOTES:
1	86275190	70377	4	SCR, 3/8-16 X 1.25 HHCS SS		
2	86010790	87163	4	WASHER, 3/8 SPLIT LOCK PLTD		
3	86002830	27196	1	CABLE TIE, .375 X 24.7		
4	86006170	66031	1	PIN, ROLL 1/8" X 3/4"L		
5	86223980	09134	3	SEALED BALL BRNG, 25MM X 52MM		
6	86219420	41510	1	HUB STEERING		
7	86223480	67450	2	RING, 52MM INTERNAL SNAP		
8	86224020	730233	1	SHAFT ASM, DRIVE PIVOT		
9	86317190	-	1	GEAR BOX DRIVE UNIT HELICAL		
10A	86011120	89262	1	WHEEL, 10 X 2, 5 X 1.06 W/KEYWAY		
10B	86259920	89273	1	WHEEL, 10 X 2. 5 W/KEYWAY, GRY		OPTION
11	86224440	730387	1	SPACER, 25.51 ID X 45 OD X 39.1 L		
12	86222720	620037	1	PLATE, BEARING RETAINERX		
13	86225810	87506	1	WASHER, ANTI-ROTATION		
14	86279710	87245	1	WASHER, M8 (2THK X 26 OD)		
15	86136640	70262	1	SCR, M8-1.25 X 20 HHMS PLTD		
16	86222770	620042	1	PLATE, BEARING COVER		
17	86279690	87243	4	WASHER, M6 SPLIT LOCK BLK		
18	86277340	70830	4	SCR, M6 X 15 HHCS BLK		
19	86223980	09134	3	SEALED BALL BRNG, .25MM X 52MM		
20	86318830	-	10	SCR, M10 X 30 SHCS		
21	86222760	620041	1	PLATE, DRIVE YOKE RH		
22	86317200	-	1	DRIVE MOTOR ASSEMBLY HELICAL		WHEEL NOT INCLUDED
-	86216210	53820	-	BRUSH SET MOTOR, 53810 86005510		

*SEE SERIAL NUMBER PAGE.

WHEEL-FRONT BRAKE

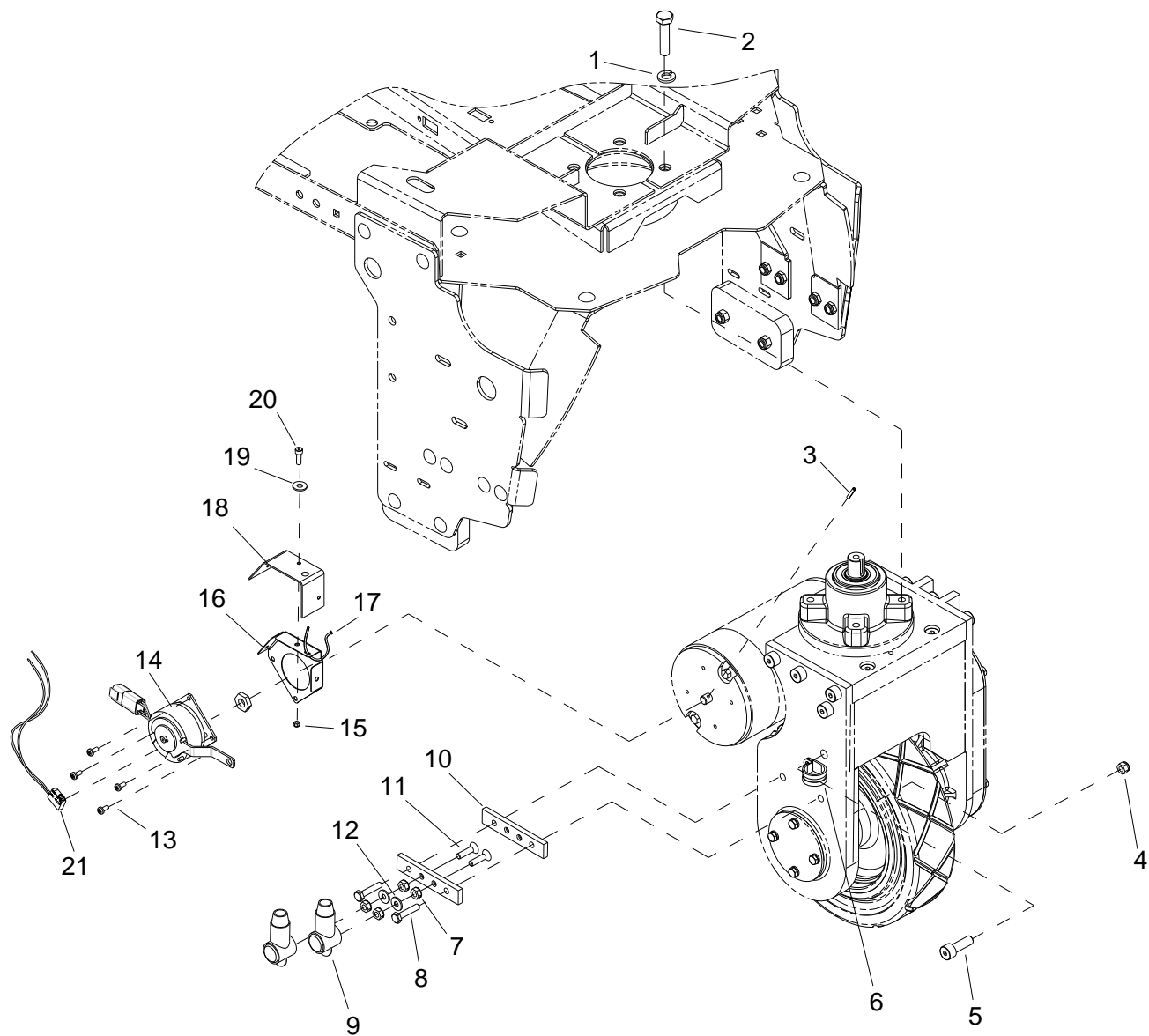

WHEEL-FRONT BRAKE

REF	PART NO.	PRV NO.	QTY	DESCRIPTION	SERIAL NO. FROM	NOTES:
1	86010790	87163	4	WASHER, 3/8 SPLIT LOCK PLTD		
2	86275190	70377	4	SCR, 3/8-16 X 1.25 HHCS SS		
3	86006170	66031	1	PIN, ROLL 1/8" X 3/4"L SS		
4	86005810	57245	2	NUT, 1/4-20 HEX NYLOCK SS		
5	86318830	-	1	SCR, M10 X 30 SHCS		
6	86233410	81270	1	CLAMP, 3/4 DIA CUSHION .406DIA		
7	86005710	57105	4	NUT, 1/4-20 HEX W/STAR WASHER		
8	86273740	70010	2	SCR, 1/4-20 X 1.50 HHCS		
9	86008920	80889	2	BOOT, RUBBER TERM. ISOLATOR		
10	86257490	76155	2	TERMINAL MOUNT		
11	86006840	70390	2	SCR, 1/4-20 X 1 FHCS PLTD		
12	86010630	87013	2	WASHER, 1/4 ID X 5/8 OD SS		
13	86273340	00-000289	4	SCR, 8-32 X 3/8 SHCS SS		
14	86001740	140816	1	BRAKE, 36VDC W/CONNECTOR		
15	86270990	57090	3	NUT, 10-32 HEX NYLOCK SS	*(24)	
16	86301950		1	PLATE, BRAKE SPACER	*(24)	
17	86264930	27050	1	CABLE TIE, 3.5" UL/CSA		
18	86301960		1	SKIRT, BRAKE	*(24)	
19	86010650	87018	3	WASHER, #10 X 9/16 OD	*(24)	
20	86274290	70162	3	SCR, 10-32 X 3/8 PPHMS SS	*(24)	
21	86320870	-	1	SWITCH, 36V BRAKE		

* SEE SERIAL NUMBER PAGE.

WHEEL-REAR

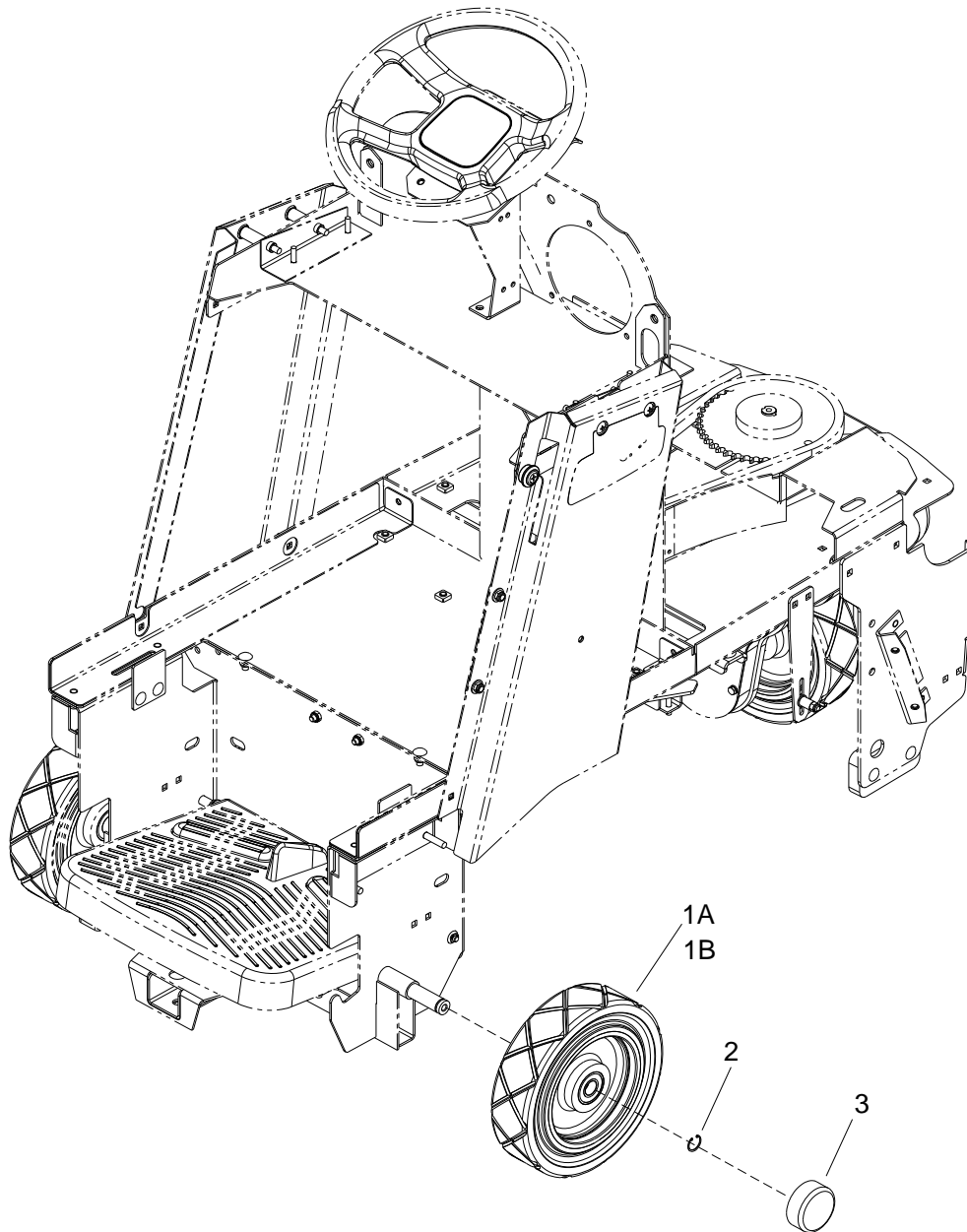

WHEEL-REAR

REF	PART NO.	PRV NO.	QTY	DESCRIPTION	SERIAL NO. FROM	NOTES:
1A	86011110	89261	2	WHEEL, 10X2.5X.787ID BEARINGS		
1B	86259930	89274	-	WHEEL, 10X2.5, W/BEARINGS, GRY		OPTIONAL
2	86008710	80623	2	RING, 3/4" EXT SNAP H-D		
3	86232130	17309	2	CAP, 2.75 ID X 1.0 L BLK VINYL		

WIRING-BATTERIES

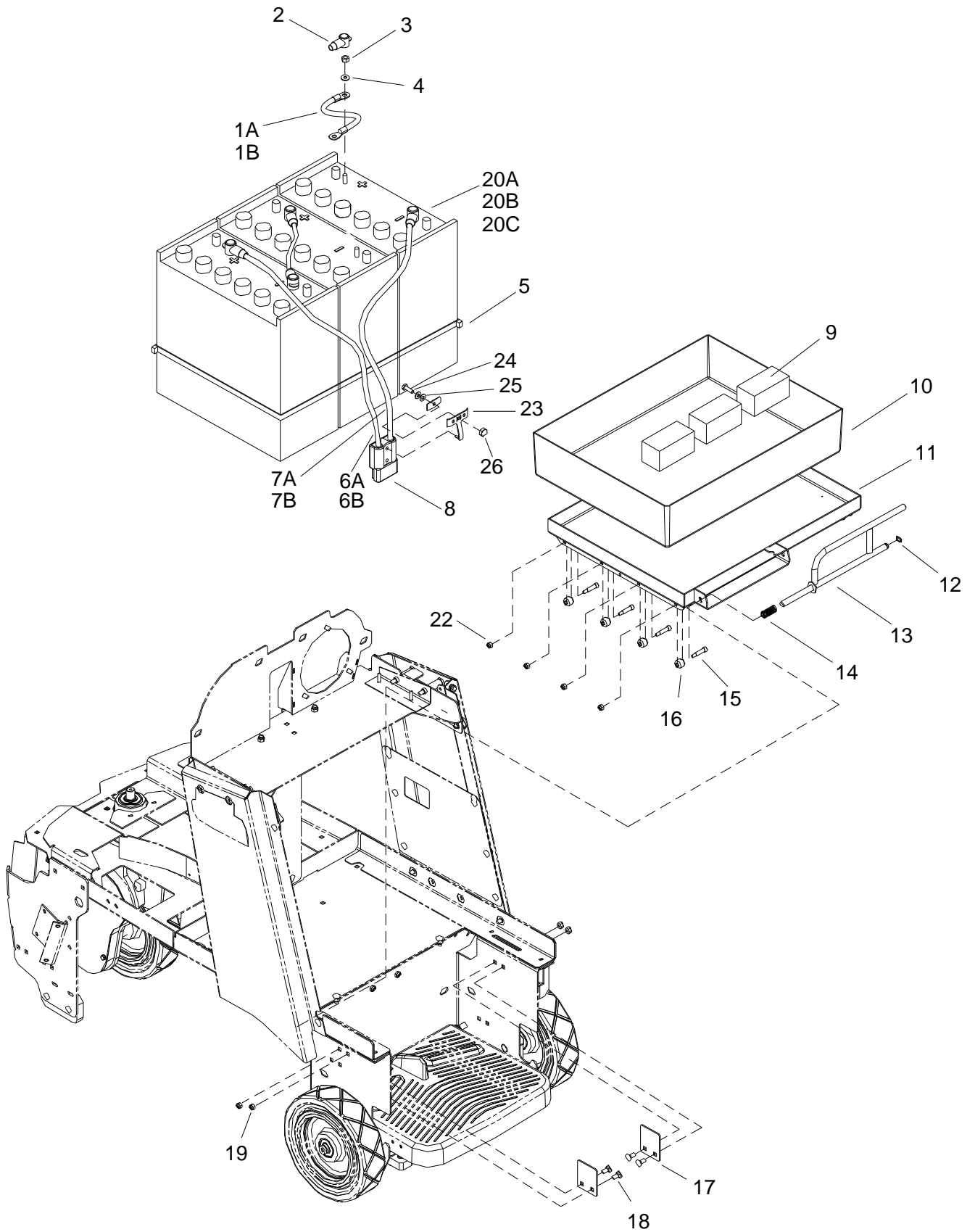

WIRING-BATTERIES

REF	PART NO.	PRV NO.	QTY	DESCRIPTION	SERIAL NO. FROM	NOTES:
1A	86260200	80872	2	WIRE, 4X14.5BK 3/8RINGX3/8RING		
1B	86002510	23125	2	CABLE ASM, BAT. JUMPER X 15"		
2	86008920	80889	6	BOOT, RUBBER TERM. ISOLATOR		
3	86271910	57295	6	NUT, 5/16-18 FLEXLOCK		
4	86010670	87029	6	WASHER, 5/16 FLAT SS		
5	86264960	27915	2	CABLE TIE, .375 X 43"		
6A	86260610	880836	1	WIRE, 4X25RD CTERM X 3/8RING	*(20)	
6B	86002570	23190	1	WIRE, 4X27 RD BCLAMP X CTERM		
7A	86260230	80876	1	WIRE, 4X30 BK CTERM X 3/8RING		
7B	86002580	23191	1	WIRE, 4X27 BK BCLAMP X CTERM		
8	86008760	80682	1	CONN, 175 DCA GRY W/O TERMS		
9	86229700	08071	3	BLOCK, 3.0 X 1.5 X 1.5		
10	86008300	78242	1	TRAY, BATTERY LINER		
11	86008410	78568	1	TRAY, BATTERY		
12	86272810	67132	1	RING, 1/2 EXT. SNAP H-D		
13	86092910	51396	1	LATCH ROD, BATTERY TRAY		
14	86254990	730313	1	SPRING, COMP, 63ODX3.5LX.047W		
15	86278150	70117	8	SHOULDER BOLT, 5/16 OD X 1.0 L		
16	86259910	89265	8	WHEEL, BATTERY TRAY		
17	86088790	78571	2	TRAY, STANDARD STOP		
18	86276070	70593	4	SCR, 5/16-18 X 3/4 CARRIAGE SS		
19	86270830	57023	4	NUT, 5/16-18 HEX NYLOCK SS		
20A	86228410	10023	3	BATTERY, 12V, 205AH		
20B	86283410	10030	3	BATTERY, 12V, 225AH		
20C	86228430	10032	3	BATTERY, 12V, AGM 198AH		
21A	86284090	02456	1	CHARGER, 36V, 20A, 115V, C175		▲
21B	86000150	02264	1	CHARGER, 36VDC/21A AGM		▲
22	86005810	57245	8	NUT, 1/4-20 HEX NYLOCK SS		
23	86233360	28038	1	CLAMP, CABLE KIT SY945	*(12)	
24	86273980	70066	1	SCREW, 10-32 X 3/4 PPHMS SS		
25	86010650	87018	1	WASHER, #10 X 9/16 OD		
26	86270890	57034	1	NUT, ACORN 10-32		

▲ NOT SHOWN – FOR WET CELL BATTERIES AND AGM BATTERIES

* SEE SERIAL NUMBER PAGE

WIRING-COMPONENTS

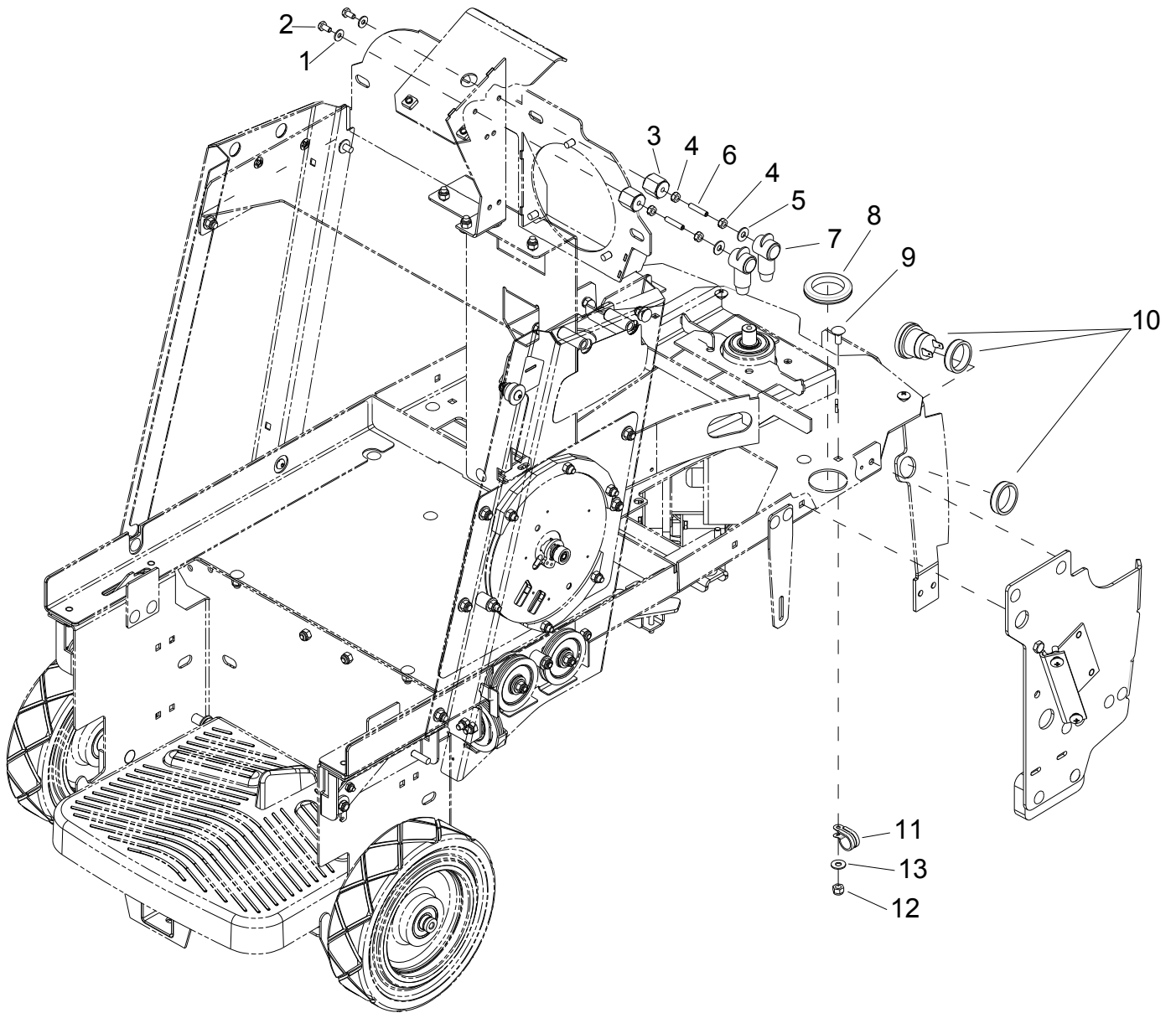

WIRING-COMPONENTS

REF	PART NO.	PRV NO.	QTY	DESCRIPTION	SERIAL NO. FROM	NOTES:
1	86010780	87162	2	WASHER, 1/4 SPLIT LOCK PLTD		
2	86273830	70020	2	SCR, 1/4-20 X 1/2 HHCS SS NP		
3	86255910	73659	2	STANDOFF, 1/4-20 X 1.0 HEX INS		
4	86005710	57105	4	NUT, 1/4-20 HEX W/STAR WASHER		
5	86010630	87013	2	WASHER, 1/4 ID X 5/8 OD SS		
6	86006850	70393	2	SET SCR, 1/4-20 1.25L		
7	86008920	80889	2	BOOT, RUBBER TERM. ISOLATOR		
8	86238500	81427	1	GROMMET, 1.703IDX2.5ODX.125GRV		
9	86276070	70593	1	SCR, 5/16-18 X 3/4 CARRIAGE SS		
10	86239720	41520	1	HORN, 108DB MINIATURE PIEZO		
11	86233410	81270	1	CLAMP, 3/4 DIA CUSHION .406DIA		
12	86270830	57023	1	NUT, 5/16-18 HEX NYLOCK SS		
13	86010670	87029	1	WASHER, 5/16 FLAT SS		

WIRING-CONTROL PANEL-BASIC-CYLINDRICAL

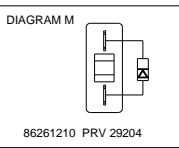
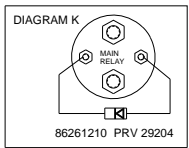
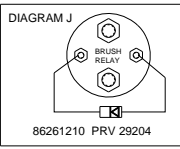
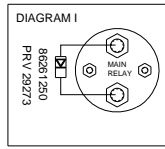
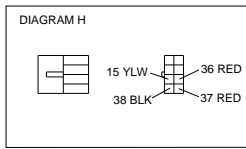
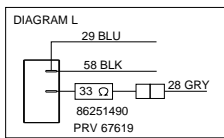
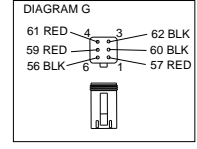
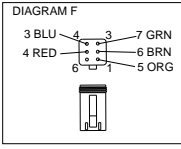
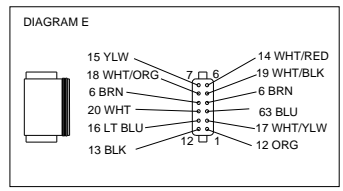
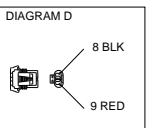
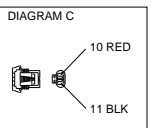
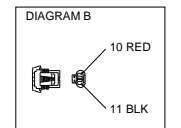
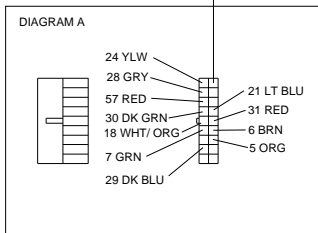
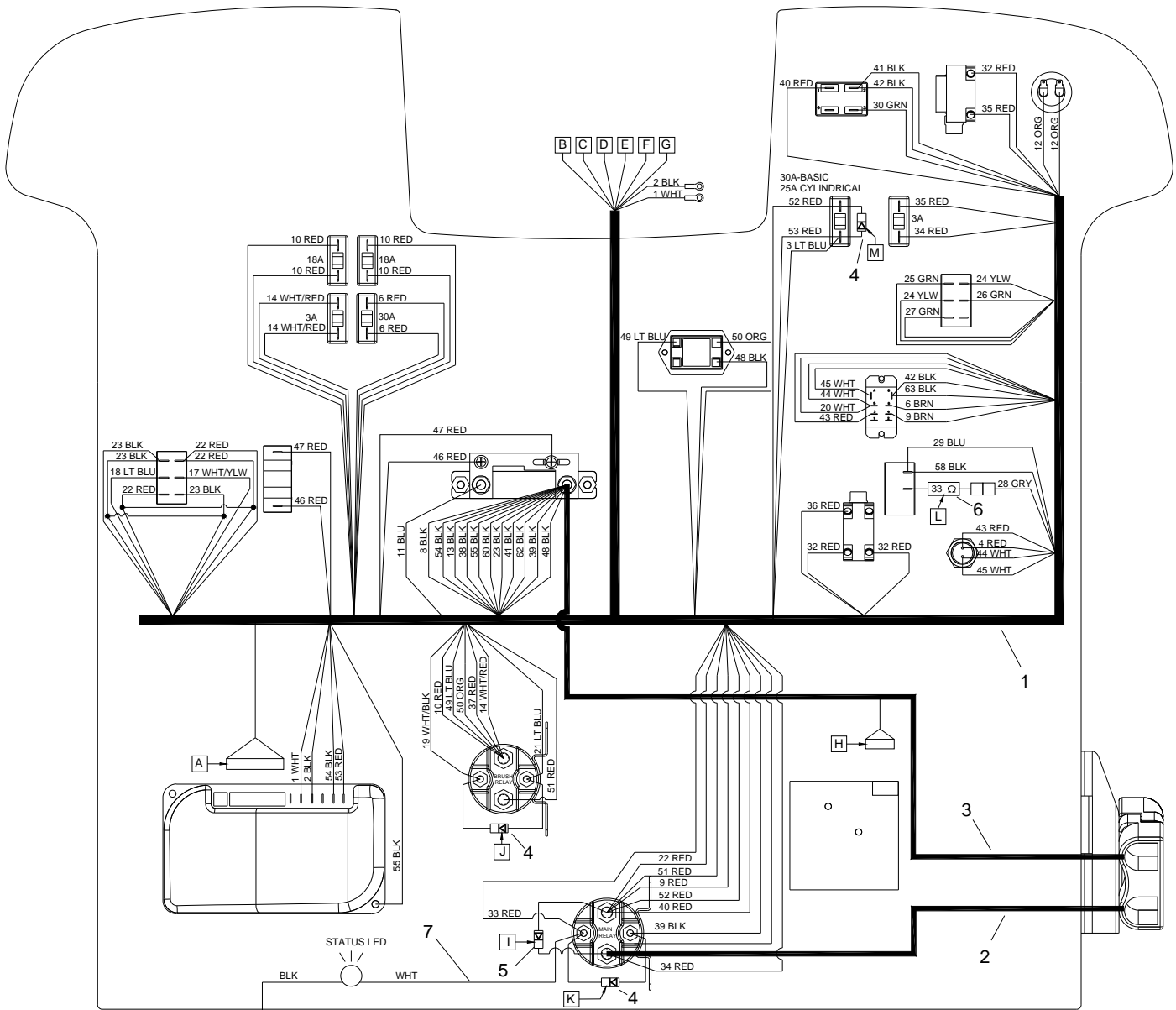

WIRING-CONTROL PANEL- BASIC - CYLINDRICAL

REF	PART NO.	PRV NO.	QTY	DESCRIPTION	SERIAL NO. FROM	NOTES:
1	86239140	41524	1	HARNESS, CONTROL PANEL BASIC		
2	86260540	880426	1	WIRE, 4X13 RD C.TERM X 5/16RING		
3	86010860	880353	1	WIRE, 4X20 BK CTERM X5/16RING		
4	86261210	29204	3	DIODE ASM, 76008, 76008		
5	86261250	29273	1	DIODE ASM, FAST RECOVERY	*(8)	
6	86251490	67619	1	RESISTOR ASM, 1/2 WATT 33 OHM	*(18)	
7	86311210	-	1	LIGHT ASM, INDICATOR, CODE		

* SEE SERIAL NUMBER PAGE

WIRING-CONTROL PANEL-DELUXE

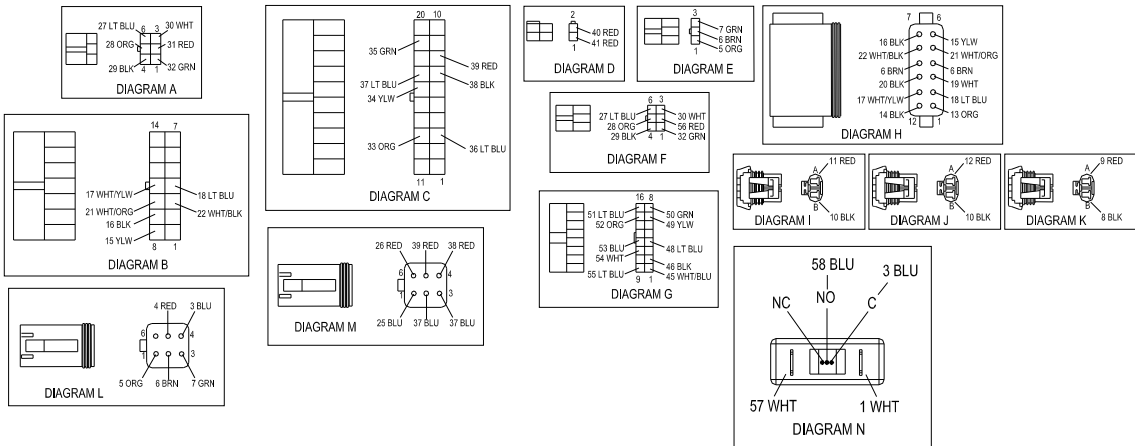
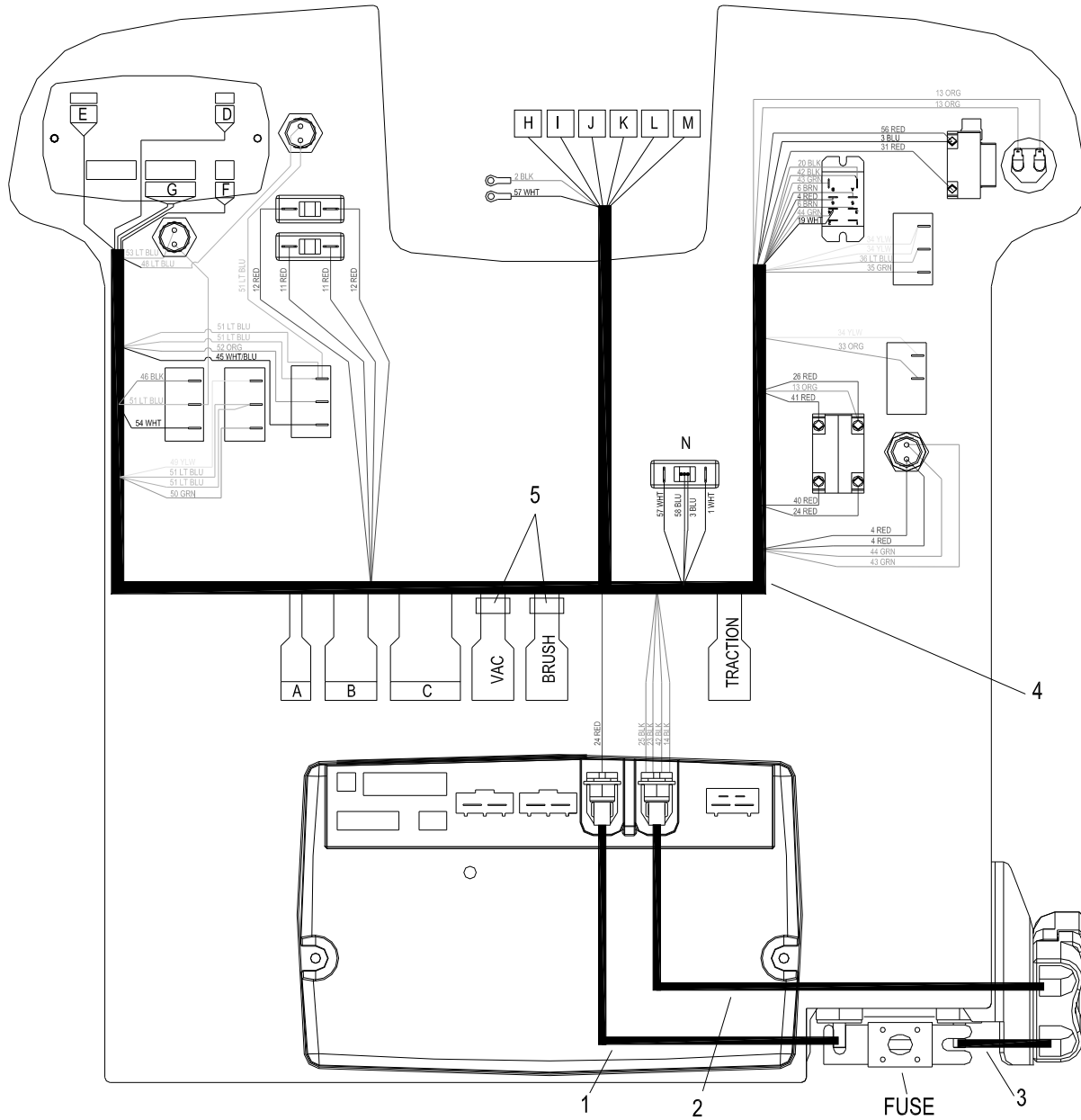

WIRING-CONTROL PANEL-DELUXE

REF	PART NO.	PRV NO.	QTY	DESCRIPTION	SERIAL NO. FROM	NOTES:
1	86260560	880428	1	WIRE, 4X10RD 5/16RING X 5/16RING		
2	86260550	880427	1	WIRE, 4X15BK C. TERM X 5/16 RING		
3	86260570	880429	1	WIRE, 4X8RD C. TERM X 5/16RING		
4	86239150	41525	1	HARNESS, CONTROL PANEL DELUXE		
5	86235780	34164	2	FERRITE CLAMP, 1.14 X 1.28 X .583		CSXE24 & CSXEO24 ONLY

WIRING- DRIVE MOTOR

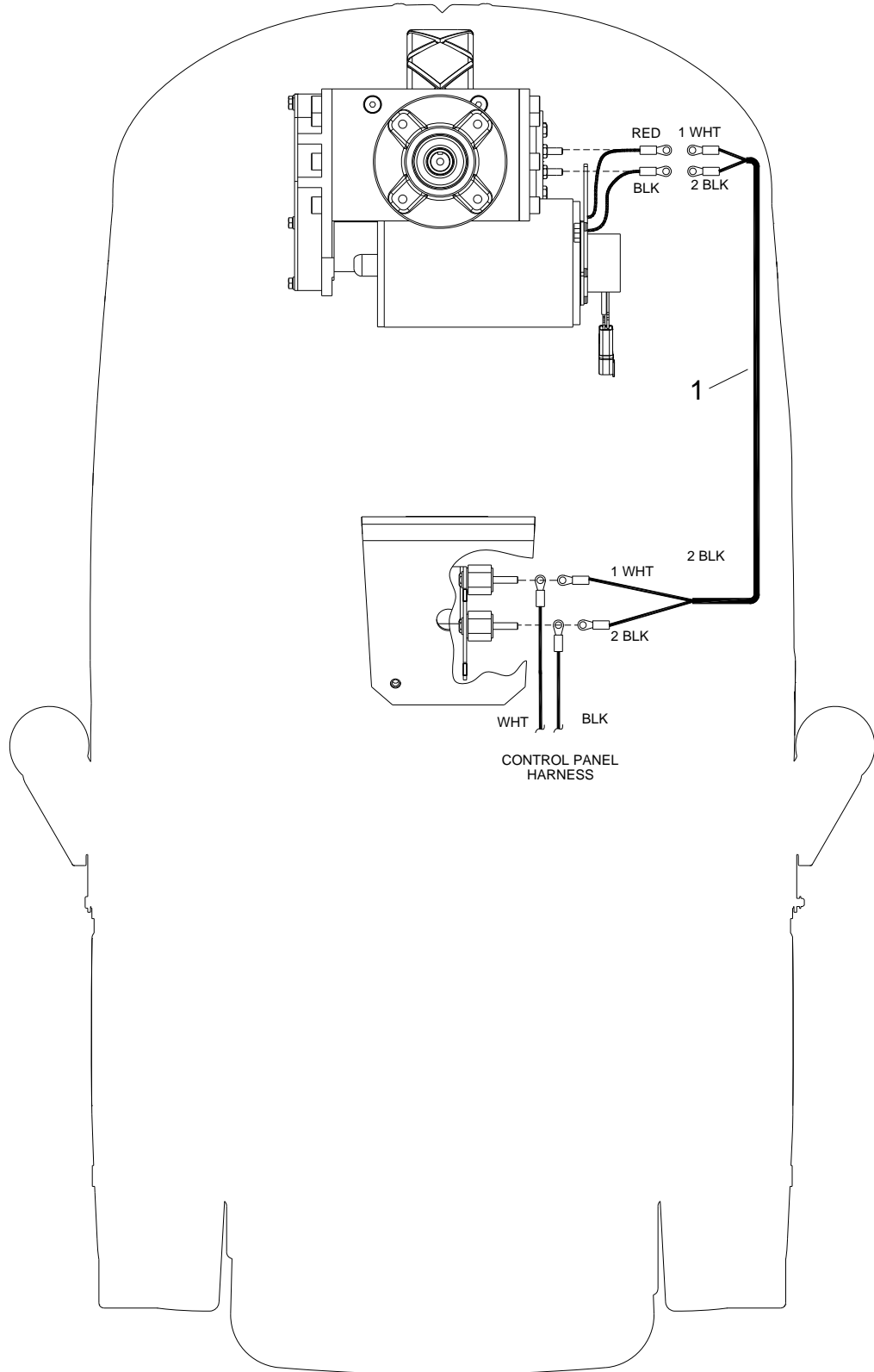

WIRING-DRIVE MOTOR

REF	PART NO.	PRV NO.	QTY	DESCRIPTION	SERIAL NO. FROM	NOTES:
1	86239120	41522	1	HARNESS, CHARIOT PROPEL		

WIRING-MAIN HARNESS

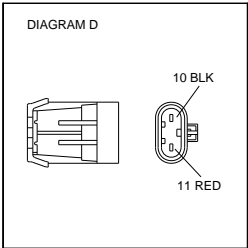
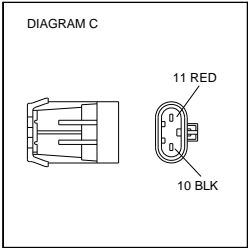
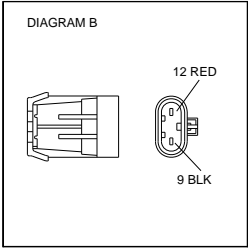
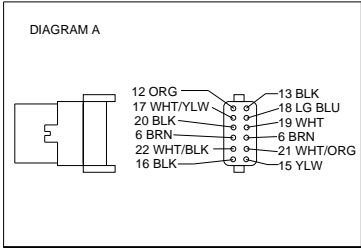
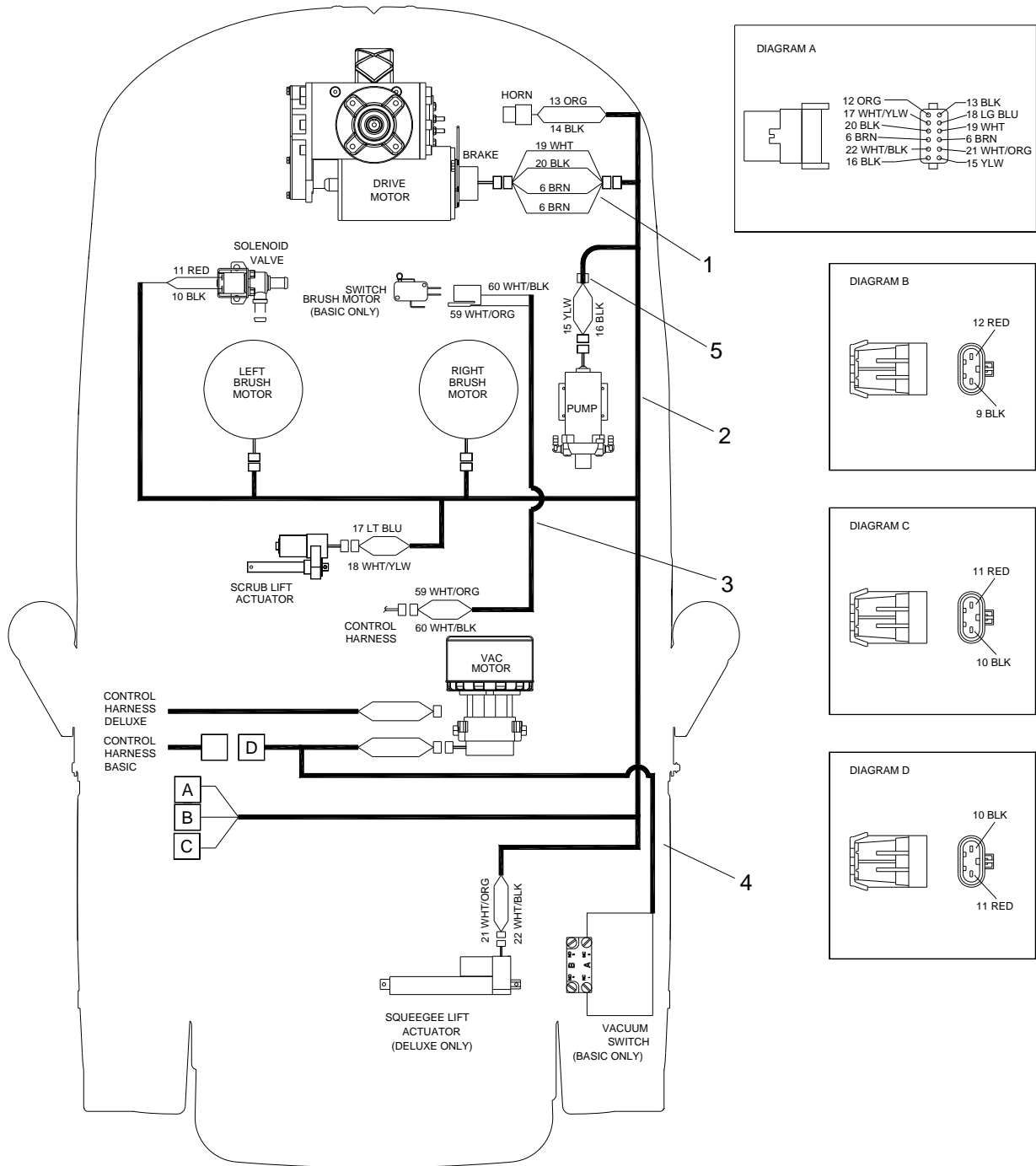

WIRING-MAIN HARNESS

REF	PART NO.	PRV NO.	QTY	DESCRIPTION	SERIAL NO. FROM	NOTES:
1	86239170	41528	1	HARNESS, BRAKE		
2	86239130	41523	1	HARNESS, MAIN		
3	86239160	41527	1	HARNESS, DECK SWITCH		BASIC ONLY
4	86239110	41521	1	HARNESS, VAC BASIC		BASIC ONLY
5	86235820	34376	1	FERRITE, .72 X .70 X 1.28		CSE24 ONLY

WIRING-PEDAL PLATFORM

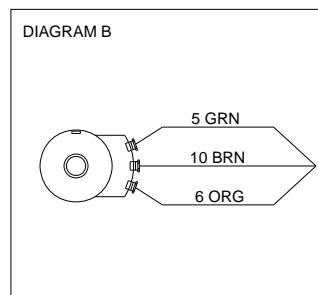
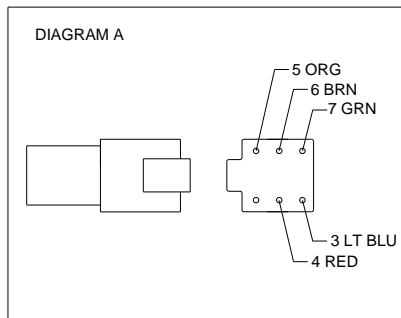
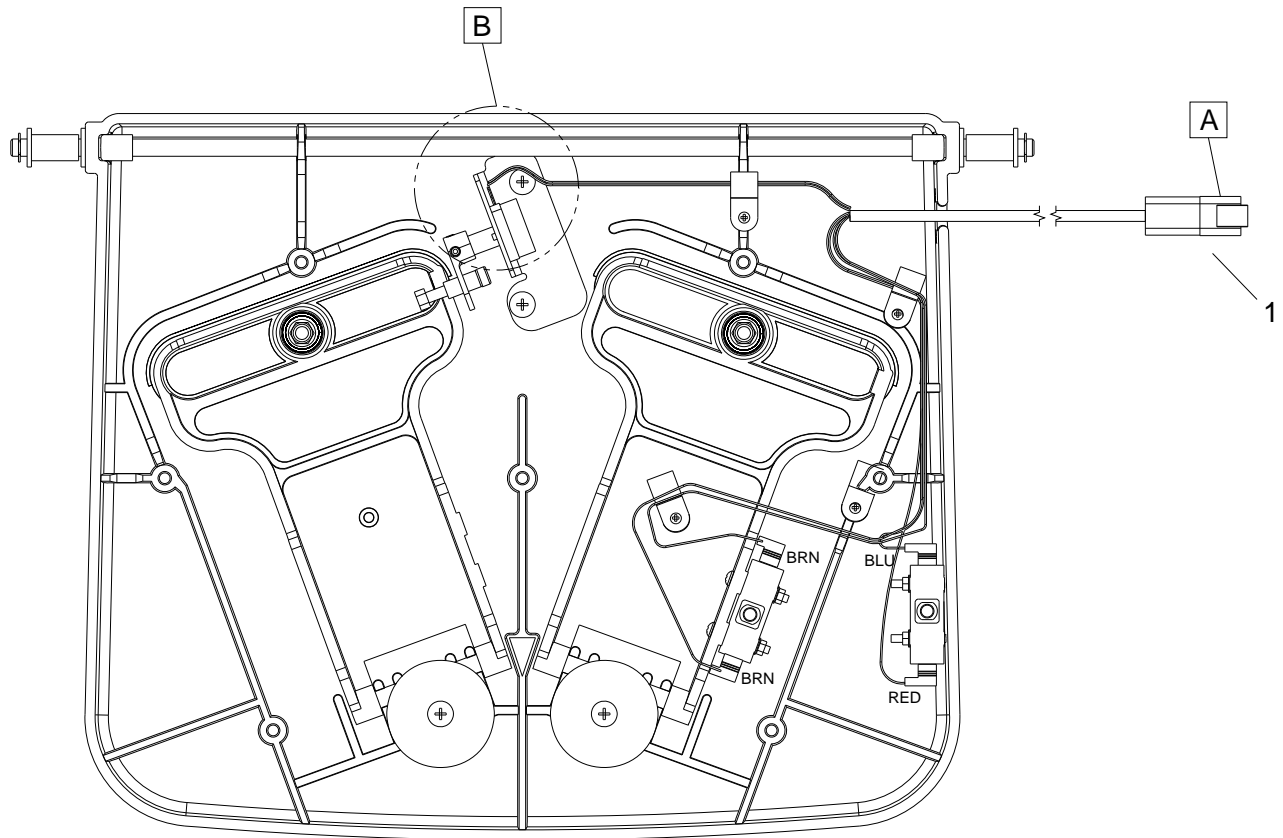

WIRING-PEDAL PLATFORM

REF	PART NO.	PRV NO.	QTY	DESCRIPTION	SERIAL NO. FROM	NOTES:
1	86218810	23717	1	HARNESS, TWISTER PEDAL		

WIRING DIAGRAM-BASIC-CYLINDRICAL

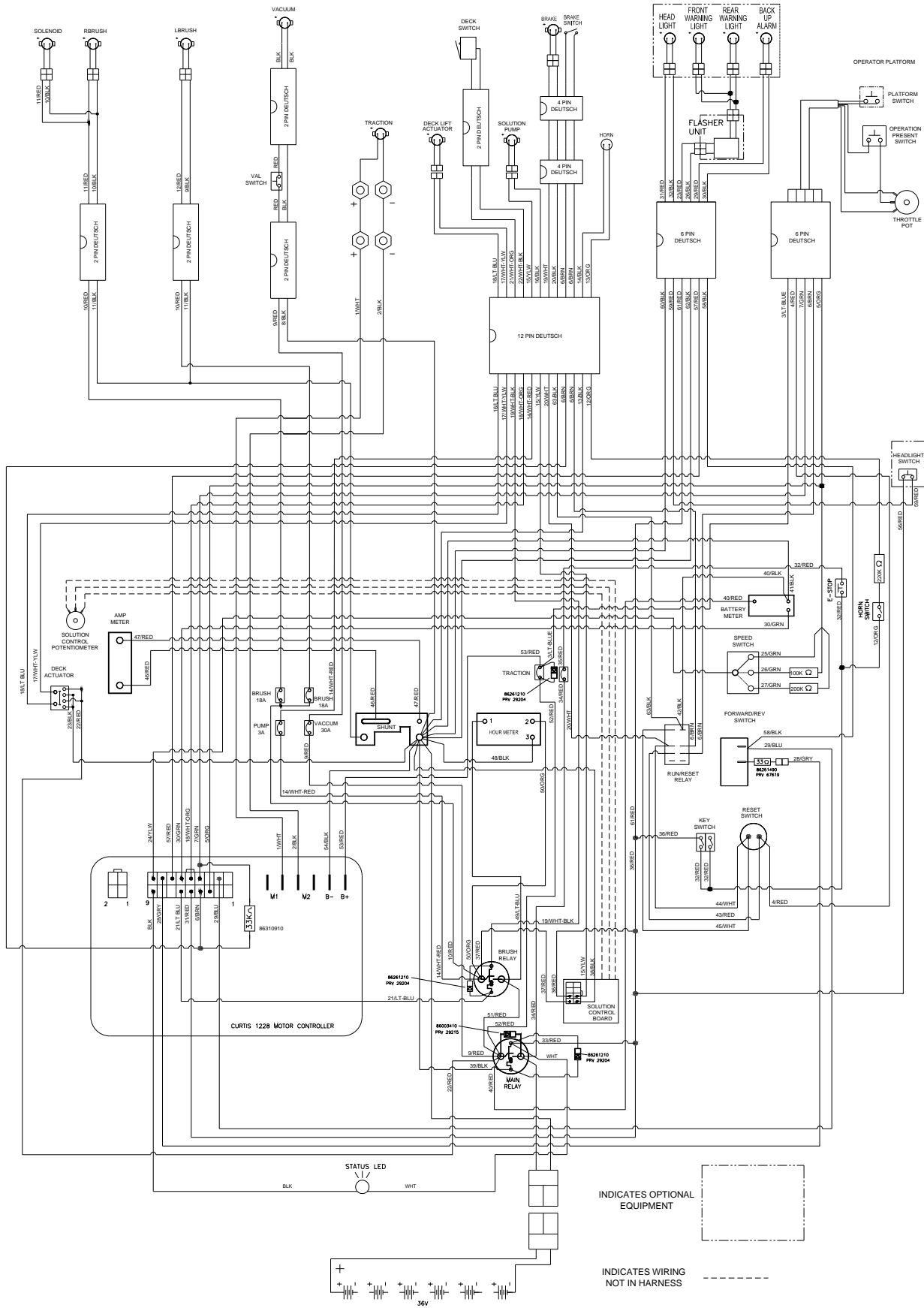

WIRING DIAGRAM-DELUXE

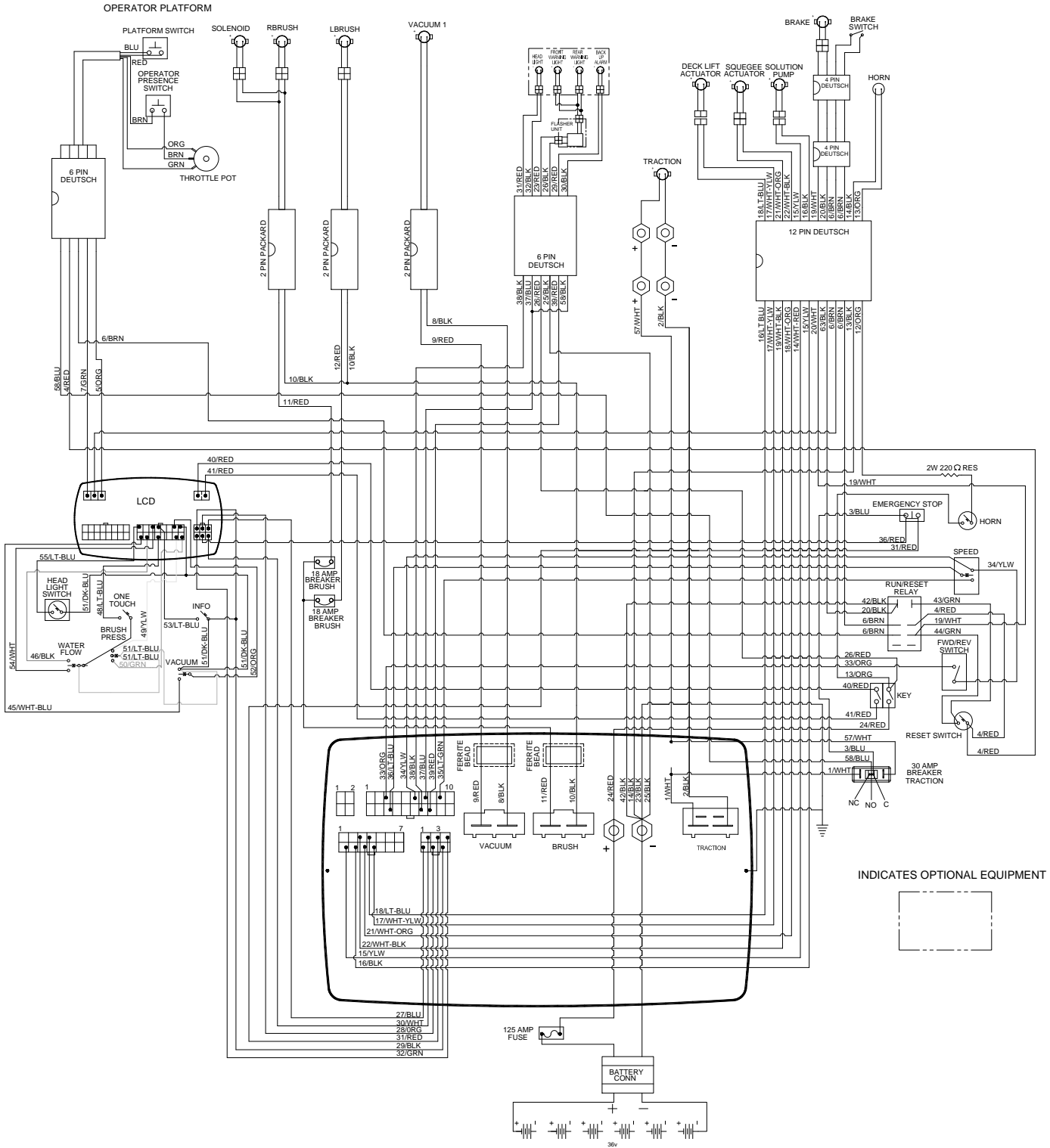

HOSE DIAGRAM - DISK

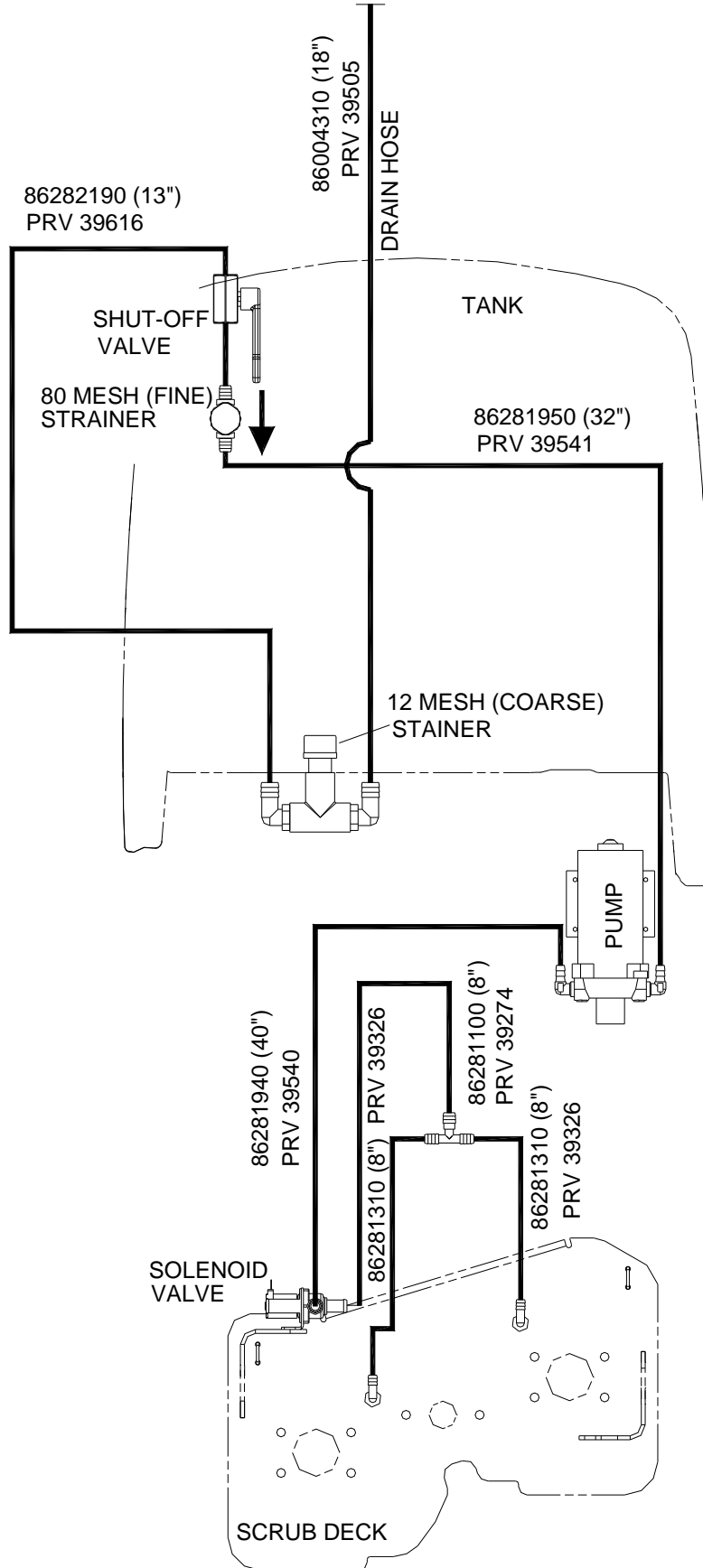

HOSE DIAGRAM - CYLINDRICAL

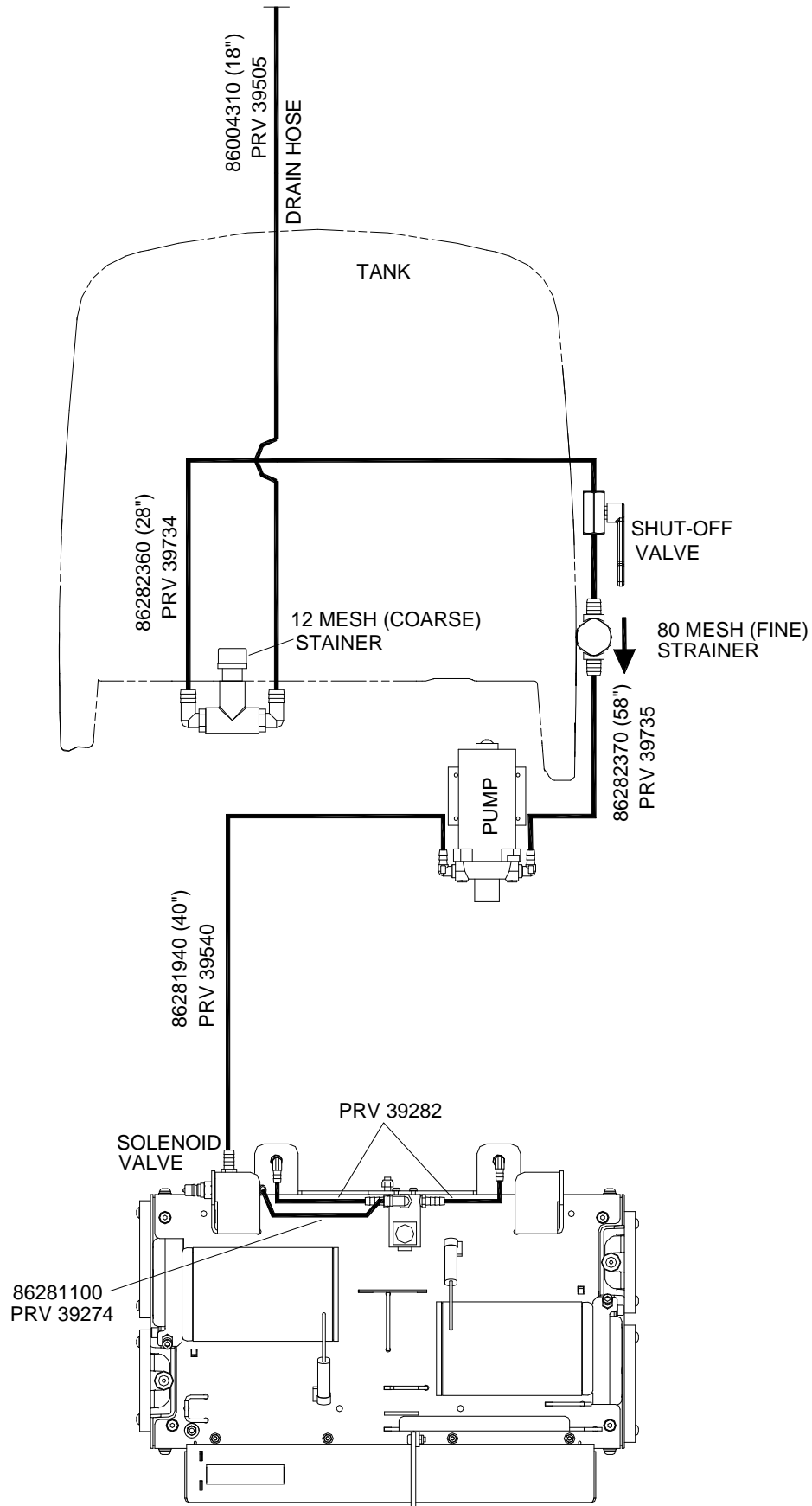

SUGGESTED SPARE PARTS

PART NO.	PRV NO.	DESCRIPTION	SERIAL NO. FROM	NOTES:
86001910	14606	BREAKER, 30A 50VDC CIRCUIT		BASIC ONLY
86001920	14607	BREAKER, 25BA 50VDC CIRCUIT		BASIC ONLY
86002000	14717	BREAKER, 3 AMP 1681-090-300		BASIC ONLY
86002010	14942	BOOT, 3/8 CIRCUIT BREAKER		
86232130	17309	CAP, 2.75 X 1.0L BLACK VINYL		
86003680	34380	FLOAT, SHUT OFF		
86004010	35274	GASKET, DOME EDGE		
86305960	-	HOSE ASM., 1.5" BLK PVC VAC X 67		
86004860	48073	KEY, SWITCH		
86004890	48095	KNOB, ALUM 3/8-16 NYLOCK NUT SS		
86006340	66347	RECOVERY DRAIN PLUG 1-3/4		
86251410	67506	RELAY, 15A 36V MINI		
86007140	72130	SWITCH, SPST 2-POSITION ROCKER		
86007170	72159	SWITCH, 2 POSITION KEY		BASIC ONLY
86007190	72161	SWITCH, DPST KEY		DELUXE ONLY
86007240	72190	SWITCH, SEALED PB ROUND		
86008790	80687	FUSE, 125 AMP		
86009200	81535	KNOB, 3/8-16 4 PRONG ALUM		
86009700	82267	PLUG, 5/8" DRAIN HOSE		
86069880	140534	BRKT, CABLE ATTACH		DELUXE ONLY
86001510	140712	BAG, INNER TANK		
86001520	140752	BLADE, AQUAMIZER, 12IN LEFT		
86001540	140753	BLADE, AQUAMIZER, 12IN RIGHT		
86001560	140754	BLADE, SKIRT, SCRUB DECK, 24 IN LEFT		
86001570	140755	BLADE, SKIRT, SCRUB DECK, 24 IN RIGHT		
86001580	140763	BLADE, SQG REAR 40.6IN LINATEX		
86001630	140764	BLADE, SQG FRONT 36.7IN RED GUM		
86001700	140780	BLADE, SKIRT, SCRUB DECK, FRONT		
86001730	140804	BREAKER, 18A 250VAC, 50VDC		
86001740	140816	BRAKE, 36 VDC W/CONNECTOR		
86002730	270085	CHAIN, ISO 08B 12.7 MM PITCH		
86231560	270097	CABLE, SQUEEGEE LIFT BASIC		
86002780	270098	CABLE, SQUEEGEE LIFT DELUXE		
86007940	73836	STRAINER, DEEP, 100 MESH		DISK ONLY
86256120	730368	STRAINER, 1/2 FPT 100 MESH		CYLINDRICAL ONLY
86313170	-	CAP, STRAINER TALL		

The logo features the letters 'ch' in a bold, italicized, sans-serif font. Behind the 'h', there is a stylized silhouette of a person in a dynamic, forward-leaning pose, possibly a cyclist or a runner, composed of horizontal lines. The entire logo is positioned above a horizontal line that extends to the left.

*ch*ariot

OPTIONS

BACK-UP ALARM - OPTION

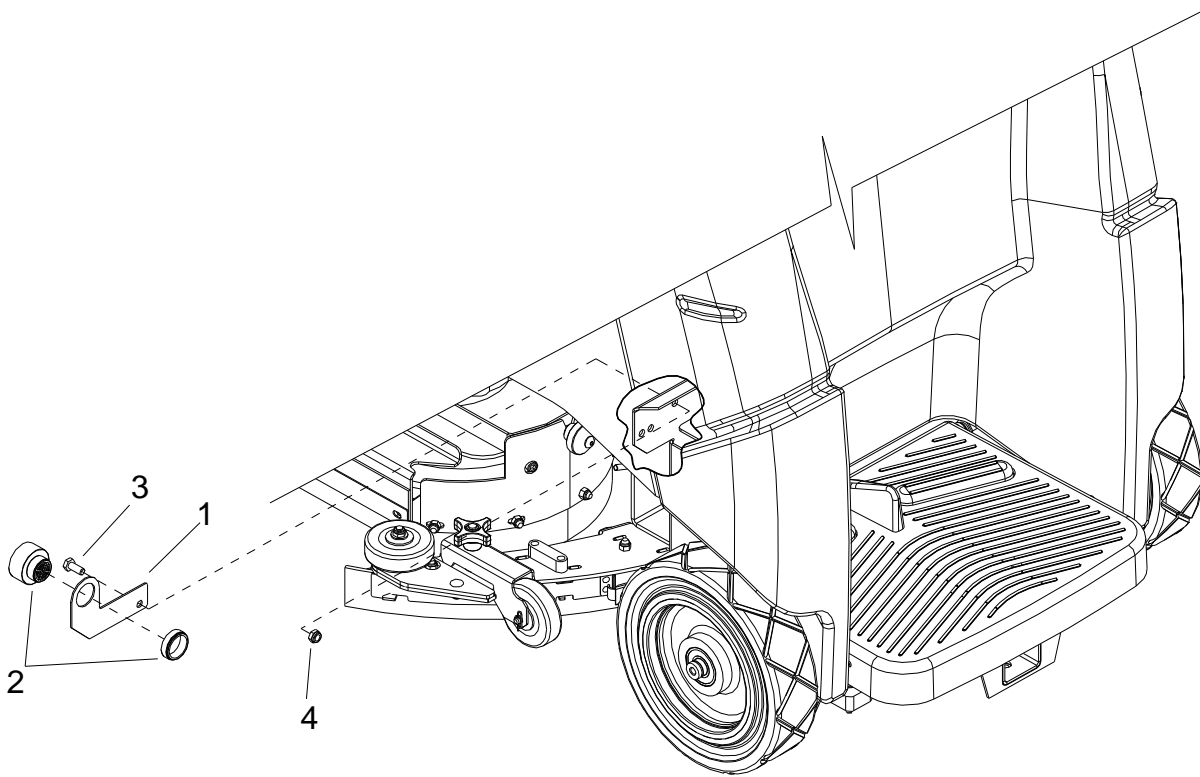

BACK-UP ALARM - OPTION

REF	PART NO.	PRV NO.	QTY	DESCRIPTION	SERIAL NO. FROM	NOTES:
1	86071140	140817	1	BRKT, BACK UP ALARM		
2	86231500	80882	1	BUZZER, PIEZO 6-28VCD		
3	86276780	70728	1	SCR, 5/16-18 X 3/4 HHCS SS		
4	86271840	57285	1	NUT, 5/16-18 HEX NYLOCK THN SS		

BATTERY CART - OPTION

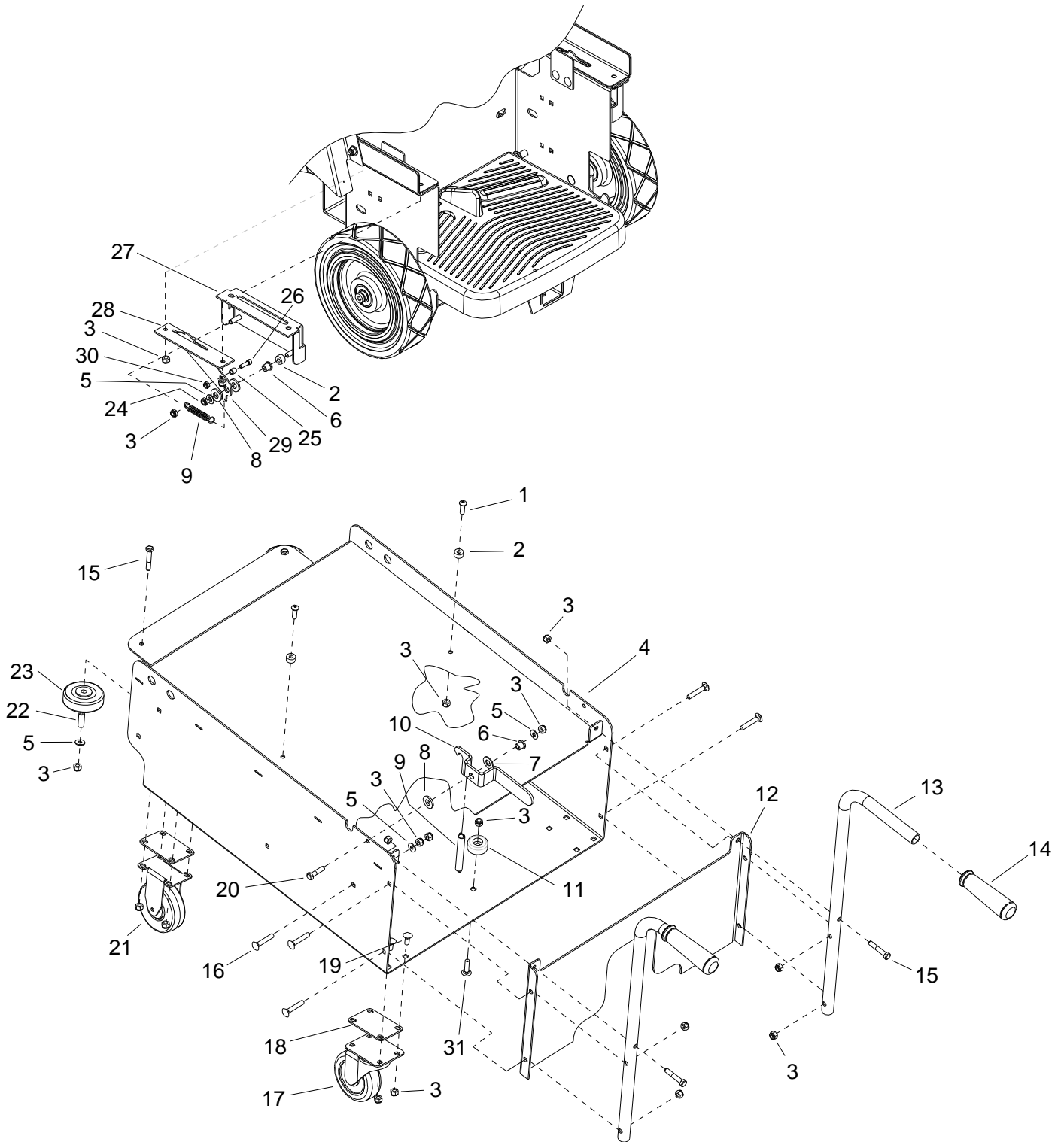

BATTERY CART - OPTION

REF	PART NO.	PRV NO.	QTY	DESCRIPTION	SERIAL NO. FROM	NOTES:
1	86006930	70514	2	SCR, 5/16-18 X 1.00 BSHCS SS		
2	86254290	730338	4	SPACER, 10D X .343ID, .5 LG		
3	86270830	57023	33	NUT, 5/16-18 HEX NYLOCK SS		
4	86077010	41517	1	HOUSING, BATTERY CART		
5	86010670	87029	7	WASHER, 5/16 FLAT SS		
6	86228840	09124	3	BEARING, FLANGED .314D X .502OD		
7	86259410	87206	1	WASHER, THRUST, .51 ID X 1 OD X .063		
8	86259400	730331	4	WASHER, THRUST .51 ID X 1 OD		
9	86254890	730018	3	SPRING, EXT, .50D X 4.0L		
10	86068490	140019	1	BRKT, TRAY CATCH		
11	86231090	80809	1	BUMPER, RUBBER 5/16" ID X 1.50		
12	86083120	66442	1	PLATE, BATTERY CART BACK		
13	86076600	38318	2	HANDLE, BATTERY CART		
14	86004070	36196	2	GRIP, POLISHER HANDLE		
15	86276790	70732	4	SCR, 5/16-18 X 1.75 HHCS SS		
16	86276690	70715	7	SCR, 5/16-18 X 1.75 CARR SS		
17	86199430	040-03	2	CASTER SWIVEL 4" 250# CPCTY		
18	86078890	620020	8	PLATE, CASTER SPACER		
19	86277130	70795	16	SCR, 5/16-18 X 1.00 CARRIAGE SS		
20	86007020	70673	1	SP SCR, 5/16-18 X 1.25 HHCS SS NP		
21	86232590	18032	2	CASTER, 4" HARD RUBBER RIGID		
22	86001350	140390	2	BUSHING, SPANNER .435 X 1.10		
23	86011020	89202	2	WHEEL, 3" DIA CUSHION RUBBER		
24	86271840	57285	2	NUT, 5/16-18 HEX NYLOCK THIN SS		
25	86008130	73958	2	SPACER, 3/8OD X .62W X .312L, AL		
26	86274730	70265	2	SCR, 1/4-20 X 3/4 SHCS PLTD		
27	86070790	140737	2	BRKT, BATTERY LOCK MOUNT		
28	86087340	730339	2	SPACER, LATCH GUIDE		
29	86070800	140738	2	BRKT, BATTERY TRAY LOCK		
30	86271870	57290	2	NUT, 1/4-20 HEX NYLOCK THIN SS		
31	86276070	70593	1	SCR, 5/16-18 X 3/4 CARRIAGE SS		

BATTERY CART - OPTION

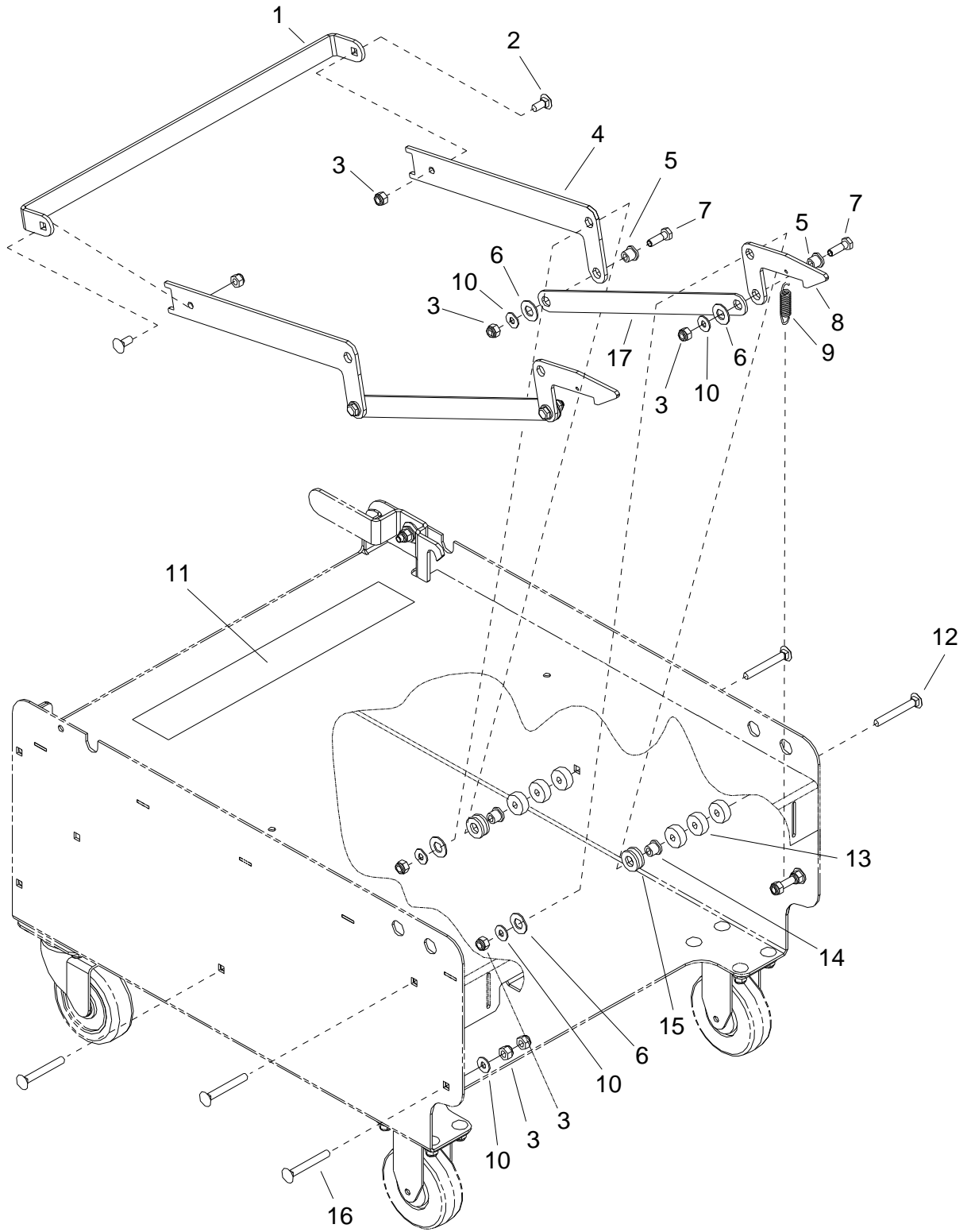

BATTERY CART - OPTION

REF	PART NO.	PRV NO.	QTY	DESCRIPTION	SERIAL NO. FROM	NOTES:
1	86078330	66478	1	PEDAL, BATTERY CART		
2	86276070	70593	2	SCR, 5/16-18 X 3/4 CARRIAGE SS		
3	86270830	57023	12	NUT, 5/16-18 HEX NYLOCK SS		
4	86087800	730307	2	STIFFENER, PEDAL, BATTERY CART		
5	86228840	09124	4	BEARING, FLANGED .314ID X .502OD		
6	86259410	87206	6	WASHER, THRUST .51 ID X 1 OD X .063		
7	86006560	70083	4	SCR, 5/16-18 X 1 HHCS SS		
8	86077140	51404	2	LATCH, BATTERY CART		
9	86226830	73268	2	SPRING, EXT .68D X 3.00L X .098W		
10	86010670	87029	10	WASHER, 5/16 FLAT SS		
11	86244280	500934	1	LABEL, BATTERY CART OPERATION		
12	86276060	70590	4	SCR, 5/16-18 X 2.5 CARR GR5		
13	86254280	730331	12	SPACER, 1.00 ODX .32ID X .375		
14	86231150	09151	4	BUSHING FLANGE, .314 X .502 OD		
15	86259400	87205	8	WASHER, THRUST .51 ID X 1 OD		
16	86276690	70715	16	SCR, 5/16-18 X 1.75 CARR SS		
17	86077530	51403	2	LINKAGE, LATCH, BATT CART		

SEAT - OPTION

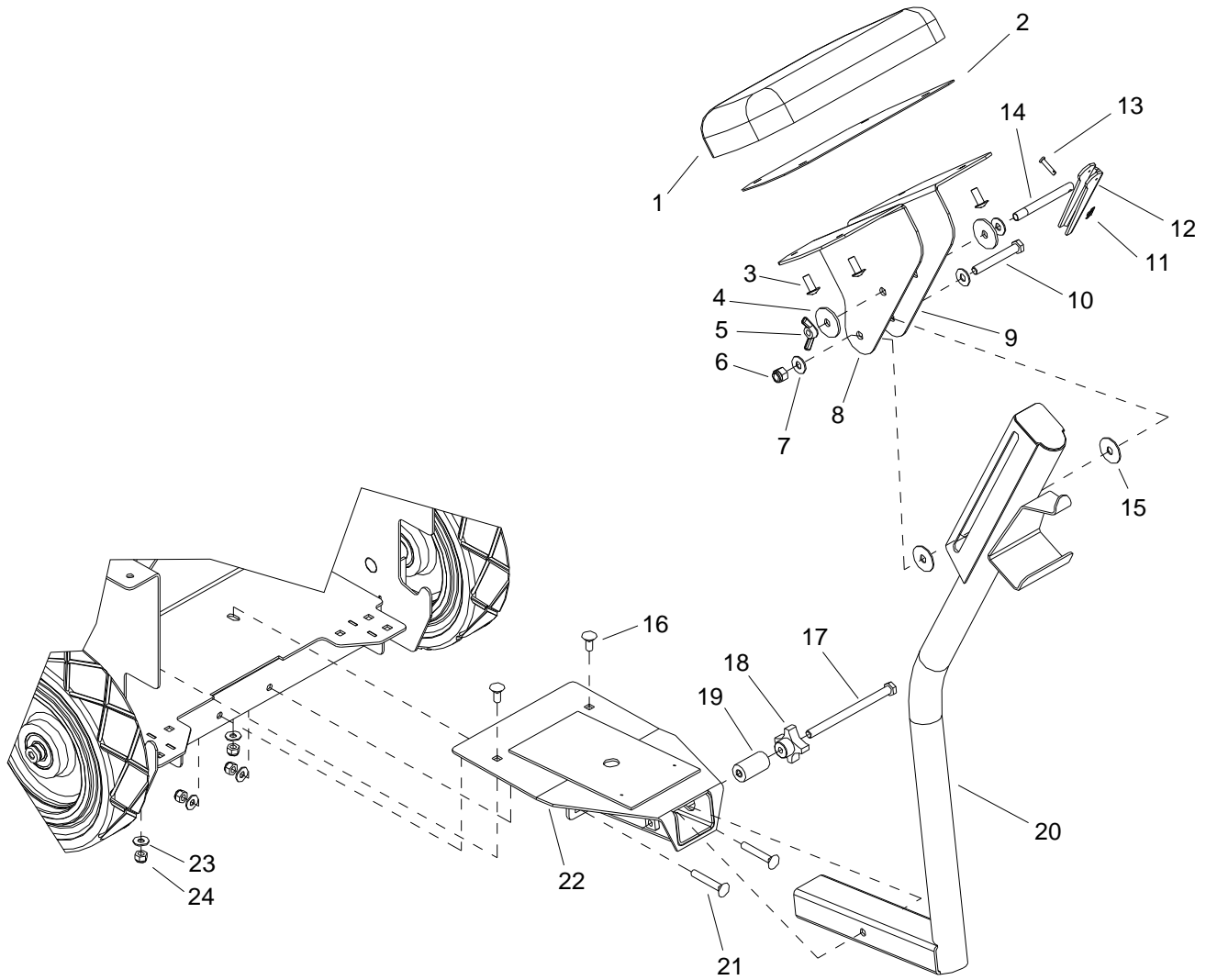

SEAT - OPTION

REF	PART NO.	PRV NO.	QTY	DESCRIPTION	SERIAL NO. FROM	NOTES:
1	86248390	730324	1	PAD, REAR REST		
2	86082640	629995	1	PLATE, SEAT COVER		
3	86276890	70752	4	SCR, 5/16-18 X 3/4 PTHMS SS		
4	86279460	87164	2	WASHER, 1/2 SPLIT LOCK		
5	86270710	01-000277	1	NUT, WING 3/8-16		
6	86271930	57297	1	NUT, 3/8-16 HEX NYLOCK SS		
7	86278910	87003	3	WASHR, 3/8 ID X 7/8 OD SS		
8	86070830	140742	1	BRKT, LEFT REAR SEAT		
9	86070840	140743	1	BRKT, RIGHT REAR SEAT		
10	86277710	730347	1	SCR, 3/8-16 X 2.75 HHCS SS		
11	86008650	80604	1	COTTER, 1/4" RING		
12	86246320	51142	1	LEVER, HANDLE LOCK		
13	86272300	66133	1	PIN, CLEVIS 3/16 X .88 PLTD		
14	86251860	66481	1	ROD, ARM HANDLE LOCK 4" LG		
15	86279620	87200	2	WASHER, .4ID X 1.3OD NYLON		
16	86276070	70593	2	SCR, 5/16-18 X 3/4 CARRIAGE SS		
17	86277510	70857	1	SCR, 3/8-16 X 5.0 HHCS SS FT		
18	86009200	81535	1	KNOB, 3/8-16 4 PRONG ALUM		
19	86254300	730350	1	SPACER, SEAT LOCK		
20	86094000	05246	1	SEAT MOUNT POST		
21	86276710	70717	2	SCR, 5/16-18 X 2.0 CARRIAGE SS		
22	86093790	05247	1	RECEIVER ASSY, SEAT MOUNT		
23	86010670	87029	4	WASHER, 5/16 FLAT SS		
24	86270830	57023	4	NUT, 5/16-18 HEX NYLOCK SS		

WARNING LIGHTS - OPTION

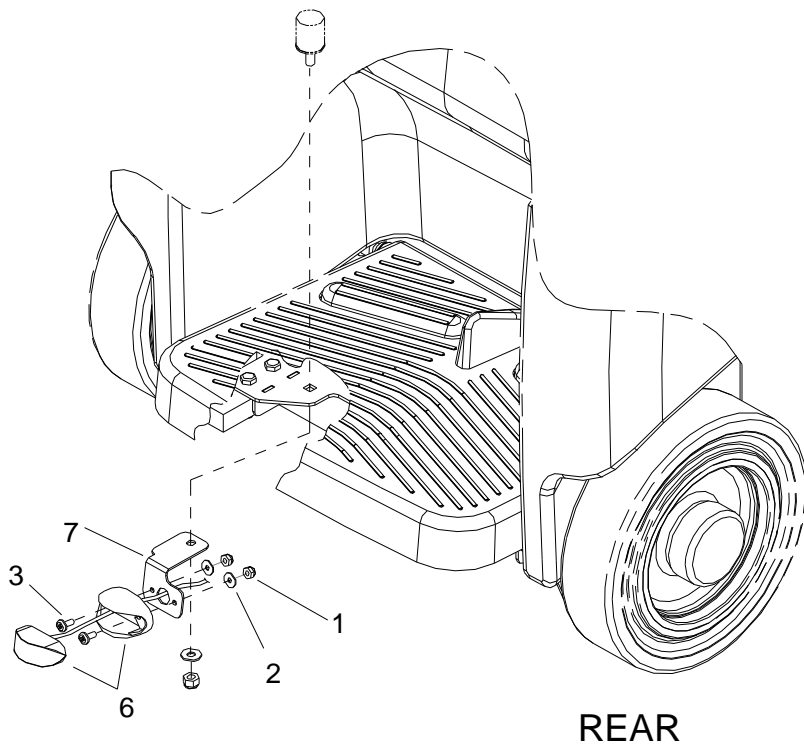
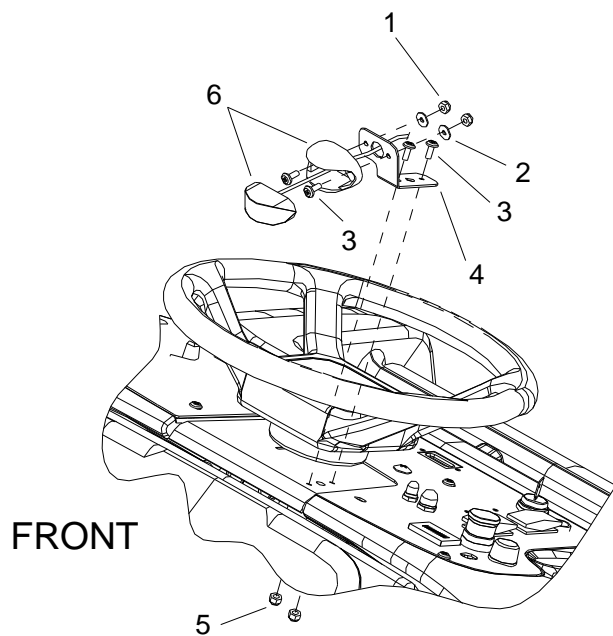

WARNING LIGHTS - OPTION

REF	PART NO.	PRV NO.	QTY	DESCRIPTION	SERIAL NO. FROM	NOTES:
1	86270990	57090	4	NUT, 10-32 HEX NYLOCK SS		
2	86010650	87018	4	WASHER, #10 X 6/16 OD		
3	86276820	70740	4	SCR, 10-32 X 1/2 PTHMS BLK		
4	86071490	140871	1	BRKT, UPPER WARNING LIGHT		
5	86270990	57090	2	NUT, 10-32 HEX NYLOCK SS		
6	86246200	51454	2	LED AMBER LIGHT, 12V		
7	86071500	140872	1	BRKT, LOWER WARNING LIGHT		



Manufacturers of Innovative Building Maintenance Equipment

Windsor Industries, Inc.
1351 West Stanford Avenue
Englewood, CO 80110 USA

Phone: 303.762.1800
FAX: 303.762.0817
<http://www.windsorind.com>

EC Declaration of Conformity

We herewith declare, Windsor Industries, Inc.
1351 W. Stanford Ave.
Englewood, CO 80110-5545 USA

that the following product complies with the appropriate essential health and safety requirements of the relevant EC Directives listed below, based on the relevant sections of the applicable EC standards and other normative documents.

Product: Chariot Scrubber Euro Deluxe 24

Product Identification: Rated 36 VDC 60 A

Trademark:



Model/Type Ref.: CSXE24

Product Description: This product is a battery powered, self-propelled, wet floor scrubber intended for commercial use.

Applicable EC Directives: EC Machinery Directive
(89/392/EEC & 91/368/EEC & 93/44/EEC & 93/68/EEC)
EC Low Voltage Directive
(73/23/EEC & 93/68/EEC)
EC Directive of Electromagnetic Compatibility
(89/336/EEC & 93/68/EEC)

Applicable Harmonized Standards: EN 60335-1: 1991
EN 60335-2-67: 1992
EN 60335-2-72: 1995
EN 55022: 1998-09
EN 55011: 1998-05
EN 61000-6-2: 1999
EN 61000-4-2: 1995
EN 61000-4-3: 1997

 4/18/05
Authorized Signature Date

Title of Signature: Vice President, Windsor Industries, Inc.

QUEST ...for Continuous Improvement.
Windsor's Quality Management System is Certified ISO 9001.



Manufacturers of Innovative Building Maintenance Equipment

Windsor Industries, Inc.
1351 West Stanford Avenue
Englewood, CO 80110 USA

Phone: 303.762.1800
FAX: 303.762.0817
<http://www.windsorind.com>

EC Declaration of Conformity

We herewith declare, Windsor Industries, Inc.
1351 W. Stanford Ave.
Englewood, CO 80110-5545 USA

that the following product complies with the appropriate essential health and safety requirements of the relevant EC Directives listed below, based on the relevant sections of the applicable EC standards and other normative documents.

Product: Chariot Scrubber Euro 24

Product Identification: Rated 36 VDC 60 A

Trademark:



Model/Type Ref.: CSE24

Product Description: This product is a battery powered, self-propelled, wet floor scrubber intended for commercial use.

Applicable EC Directives: EC Machinery Directive
(89/392/EEC & 91/368/EEC & 93/44/EEC & 93/68/EEC)
EC Low Voltage Directive
(73/23/EEC & 93/68/EEC)
EC Directive of Electromagnetic Compatibility
(89/336/EEC & 93/68/EEC)

Applicable Harmonized Standards: EN 60335-1: 1991
EN 60335-2-67: 1992
EN 60335-2-72: 1995
EN 55022: 1998-09
EN 55011: 1998-05
EN 61000-6-2: 1999
EN 61000-4-2: 1995
EN 61000-4-3: 1997

Authorized Signature

3/24/05
Date

Title of Signature: Vice President, Windsor Industries, Inc.

QUEST
...for Continuous Improvement.
Windsor's Quality Management System is Certified ISO 9001.



Manufacturers of Innovative Building Maintenance Equipment

Windsor Industries, Inc.
1351 West Stanford Avenue
Englewood, CO 80110 USA

Phone: 303.762.1800
FAX: 303.762.0817
<http://www.windsorind.com>

EC Declaration of Conformity

We herewith declare, Windsor Industries, Inc.
1351 W. Stanford Ave.
Englewood, CO 80110-5545 USA

that the following product complies with the appropriate essential health and safety requirements of the relevant EC Directives listed below, based on the relevant sections of the applicable EC standards and other normative documents.

Product: Chariot Scrubber Euro 24 Scrub Plus

Product Identification: Rated 36 VDC 60 A

Trademark:



Model/Type Ref.: CSE24SP

Product Description: This product is a battery powered, self-propelled, wet floor scrubber intended for commercial use.

Applicable EC Directives: EC Machinery Directive
(89/392/EEC & 91/368/EEC & 93/44/EEC & 93/68/EEC)
EC Low Voltage Directive
(73/23/EEC & 93/68/EEC)
EC Directive of Electromagnetic Compatibility
(89/336/EEC & 93/68/EEC)

Applicable Harmonized Standards: EN 60335-1: 1991
EN 60335-2-67: 1992
EN 60335-2-72: 1995
EN 55022: 1998-09
EN 55011: 1998-05
EN 61000-6-2: 1999
EN 61000-4-2: 1995
EN 61000-4-3: 1997

Authorized Signature

6-27-05
Date

Title of Signature: Vice President, Windsor Industries, Inc.



SERIAL NUMBERS

REF. NO.	MODEL: SERIAL #
1	CS24, CSE24, CSX24, CSXE24, CSXE024, CSE24SP, CS24SP : 1000170494
2	CS24, CSE24, CSX24, CSXE24, CSXE024, CSE24SP, CS24SP : 1000140332
3	CS24, CSE24, CSX24, CSXE24, CSXE024, CSE24SP, CS24SP : 1000143553
4	CS24, CSE24, CSX24, CSXE24, CSXE024, CSE24SP, CS24SP : 1000143906
5	CS24, CSE24, CSX24, CSXE24, CSXE024, CSE24SP, CS24SP : 1000144785
6	CS24, CSE24, CSX24, CSXE24, CSXE024, CSE24SP, CS24SP : 1000149450
7	CS24, CSE24, CSX24, CSXE24, CSXE024, CSE24SP, CS24SP : 1000149664
8	CS24, CSE24, CSX24, CSXE24, CSXE024, CSE24SP, CS24SP : 1000150256
9	CS24, CSE24, CSX24, CSXE24, CSXE024, CSE24SP, CS24SP : 1000150384
10	CS24, CSE24, CSX24, CSXE24, CSXE024, CSE24SP, CS24SP : 1000151588
11	CS24, CSE24, CSX24, CSXE24, CSXE024, CSE24SP, CS24SP : 1000154281
12	CS24, CSE24, CSX24, CSXE24, CSXE024, CSE24SP, CS24SP : 1000154660
13	CS24, CSE24, CSX24, CSXE24, CSXE024, CSE24SP, CS24SP : 1000155938
14	CS24, CSE24, CSX24, CSXE24, CSXE024, CSE24SP, CS24SP : 1000156273
15	CS24, CSE24, CSX24, CSXE24, CSXE024, CSE24SP, CS24SP : 1000157499
16	CS24, CSE24, CSX24, CSXE24, CSXE024, CSE24SP, CS24SP : 1000157501
17	CS24, CSE24, CSX24, CSXE24, CSXE024, CSE24SP, CS24SP : 1000157685
18	CS24, CSE24, CSX24, CSXE24, CSXE024, CSE24SP, CS24SP : 1000159164
19	CS24, CSE24, CSX24, CSXE24, CSXE024, CSE24SP, CS24SP : 1000159653
20	CS24, CSE24, CSX24, CSXE24, CSXE024, CSE24SP, CS24SP : 1000160355
21	CS24, CSE24, CSX24, CSXE24, CSXE024, CSE24SP, CS24SP : 1000168941
22	CS24, CSE24, CSX24, CSXE24, CSXE024, CSE24SP, CS24SP : 1000170203
23	CS24, CSE24, CSX24, CSXE24, CSXE024, CSE24SP, CS24SP : 10060140000046
24	CS24 : 10060210000104
25	CS24 : 10060210000143
26	CS24 : 10060210000178
27	CSE24 : 10060250000006
28	CSX24 : 10060270000498
29	CSXE24 : 10060290000001
30	CSXE024 : 10060300000001
31	CSE24: 10060250000007 , CSE24SP: 10060260000003 , CSXE024: 10060300000001 , CSX24: 10060270000736 , CSX24X: 10060280000078 , CS24: 1006021000252 , CS24SP: 10060220000080 , CS24SPX: 10060230000003 , CS24X 100602400000018
32	CSX24: 10060270000837 , CSXE24: 10060290000028 , CSXE024: 10060300000001
33	CSE24: 10060250000007 , CSXE024: 10060300000001 , CSX24: 10060270000837 , CSX24X: 10060280000085 , CS24: 1006021000317 , CS24X 100602400000024 , CSXE24 10060290000029
34	CS24: 10060210000315 , CSX24: 10060270000845 , CSXE024: 10030300000001 , CSE24: 10060250000007 , CSXE24: 10060290000029 , CS24SP: 10060220000091 , CSE24SP: 10060260000003