

290/350 SERIES

TOMCAT

Operator and Parts Manual

290 Rider Scrubber

350 Rider Scrubber

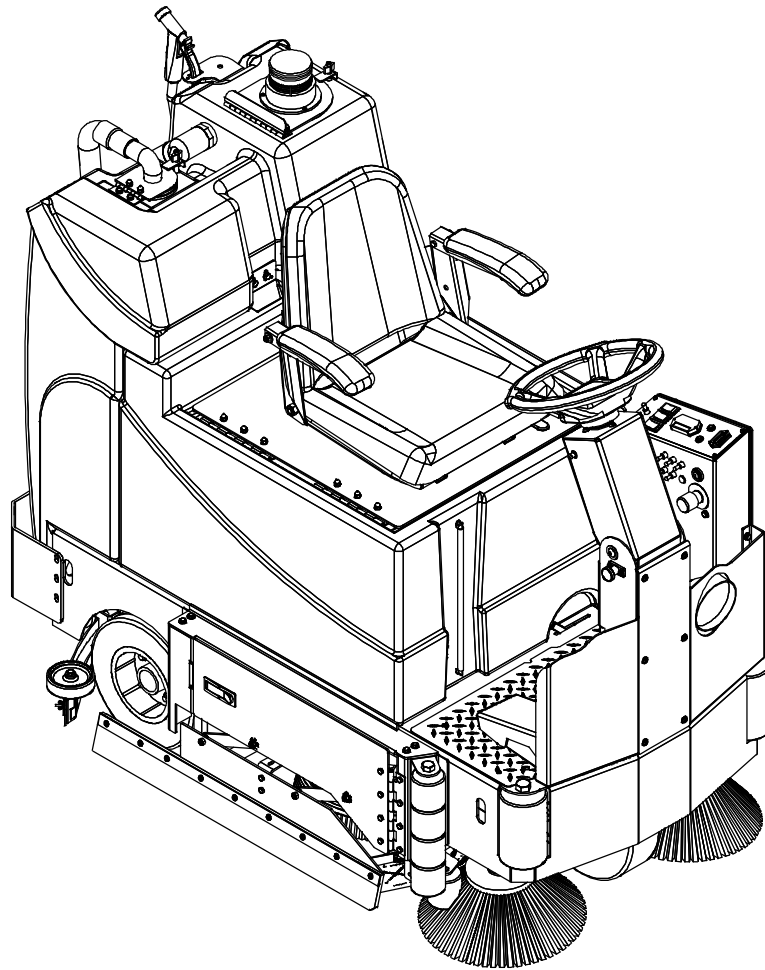

Mid-Central Corporation
P.O. Box 241
Racine, Wisconsin 53401

Phone: 1-800-450-9824
Fax: 1-866-632-6961

www.tomcatequip.com

TOMCAT

290/350 RIDER SCRUBBERS

THESE TOUGH, COMPACT SCRUBBERS COMBINED THE PRODUCTIVITY OF RIDERS WITH THE MANEUVERABILITY OF WALK-BEHINDS. TOMCATS ARE DESIGNED TO CLEAN SCHOOLS, MALLS, WAREHOUSES, RETAIL OUTLETS, WHILE STANDING UP TO THE REGORS OF CONTRACT CLEANING.

WITH TWO SPECIALIZED CLEANING SYSTEMS TO CHOOSE FROM, TOMCATS OFFER THE PERFORMANCE AND CAPACITY REQUIRED TO CLEAN YOUR UNIQUE APPLICATION.

THE TWO "DISK" MACHINES, WITH 29", AND 35" SCRUB PATHS, OFFER GIMBALED BRUSH DRIVE AND 35% MORE SCRUBBING POWER THAN COMPETITIVE BRANDS.

THE "CYLINDRICAL" MACHINES, OFFER ALL THE PERFORMANCE OF DISK SCRUBBERS PLUS THE ABILITY TO SWEEP. THE CYLINDRICAL PICKS UP WOODCHIPS, NAILS, BROKEN GLASS, GRAVEL, AND METAL CHIPS. THE DEBRIS IS HELD IN THE SLIDE-OUT HOPPER WHICH PERMITS EASY DISPOSAL.

PRODUCTIVITY IS A FUNCTION OF SCRUB WIDTH, RUN TIME AND TANK CAPACITY. THESE TOMCATS TOP THE CHART, WHILE MAINTAINING UNSURPASSED MANUVERABILITY. WITH 40% LAGER TANKS, WIDER SCRUB PATHS, HIGHER SCRUBING PRESSURES, MORE VACUUM, AND BIGGER BATTERY PACKS YOU WILL HAVE LESS STOPING TO REFILL, FEWER TRIPS DOWN THE AISLE, LESS DOUBLE SCRUBBING, DRY SAFE CLEAN FLOORS, AND EXTRA RUN TIME.

THE OPERATOR SITS IN A SPRING- SUSPENSIONED, FULLY ADJUSTABLE, MID-BACK CHAIR. THE STEERING COLUMN HAS FOUR SETTINGS, FURTHER ENHANCING OPERATOR COMFORT. HEADLIGHT, HORN BACKUP ALARM, NON-MARKING TIRES, AND ARMRESTS ARE STANDARD. OPERATORS ARE ABLE TO TURN WITHIN A 64" AISLE, WHILE MAINTAINING EXCELLENT WATER CONTROL. WE ALSO OFFER, FOR CLEANING IN REMOTE AREAS, A COMPLETE LINE OF HAND TOOLS, INCLUDING VAC WANDS, SPRAY HOSES, AND POWERED SCRUB WANDS.

TOMCATS EXCLUSIVE "CENTRAL COMMAND II" ENERGY MANAGEMENT SYSTEM OFFERS AUTOMATIC CONTROLS. WHEN THE OPERATOR STOPS THE MACHINE, BRUSHES, AND SOLUTION FLOW STOPS, THE SAFETY-SET PARKING BRAKE IS APPLIED, AND VACUUM STOPS AFTER A 22 SECOND DELAY. ALL "CENTRAL COMMAND" COMPONENTS, INCLUDING THE CONTROLLER, AUTO REST CIRCUIT BREAKERS, AND MARINE DUTY SWITCHES, ARE IN A SEALED MODULE.

TOMCATS USE THE MOST POWERFUL MOTORS AVAILABLE, SO THEY ARE TYPICALLY RUN AT ONLY 75% OF THEIR CAPACITY. THIS LEAVES POWER IN RESERVE FOR TIMES WHERE HEAVY STRIPPING IS REQUIRED, AND GREATLY PROLONGS MOTOR LIFE. THESE TOMCATS ARE CONSTRUCTED OF HEAVY GAUGE STEEL, AND SPECIALLY PLATED OR POWDER PAINTED TO PROTECT YOUR INVESTMENT. THE TANKS HAVE EXTRA THICK WALLS, QUALITY INSERTS, AND "THROUGH TUBES" FOR STRENGTH. STEEL BUMPERS PROTECT THE SCRUBHEAD AND FRONT END FROM COLLISION DAMAGE. THE CORNER ROLLERS ARE POLYURETHANE, AND TALL TO DISPERSE THE FORCE OF IMPACT WITHOUT LEAVING MARKS ON YOUR WALLS. THE WHOLE MACHINE IS PUT TOGETHER WITH STAINLESS STEEL FASTENERS TO HELP PROLONG THE LIFE AND DURABILATY OF YOUR MACHINE.

TABLE OF CONTENTS

MACHINE INFORMATION FORM	PAGE 1	<u>PARTS BREAKDOWN ILLUSTRATION</u>	
WARRANTY REGISTRATION FORM	PAGE 2		
MACHINE SPECIFICATIONS	PAGE 3	SOLUTION SYSTEM	PAGE 23-24
COMMON WEAR PARTS	PAGE 4	RECOVERY SYSTEM	PAGE 25-26
SAFETY MESSAGES	PAGE 5	FRAME TOP	PAGE 27-28
!!SAFETY PRECAUTIONS!!	PAGE 6	FRAME BOTTOM	PAGE 29-30
MACHINE FEATURES AND CONTROLS	PAGE 7-8	DOOR WIPER/ROLLER ASSEMBLY	PAGE 31-32
MACHINE SETUP	PAGE 9-10	STEERING /TRACTION ASSEMBLY	PAGE 33-34
OPERATION	PAGE 11-12	ACTUATOR SLIDE ASSEMBLY	PAGE 35-36
CHARGING BATTERIES	PAGE 13	DISK SCRUBHEAD ASSEMBLY	PAGE 37-38
MAINTENANCE	PAGE 14	CYLINDRICAL DECK ASSEMBLY	PAGE 39-40
STORING MACHINE	PAGE 14	CYLINDRICAL MECHANICAL	PAGE 41-42
PREVENTATIVE MAINTENANCE RECORDS	PAGE 15-16	SQUEEGEE ASSEMBLY	PAGE 43-44
LCD MENU DISPLAY	PAGE 17	CENTRAL COMMAND II COMPONENTS	PAGE 45-46
TOUBLESHOOTING CENTRAL COMMAND	PAGE 18-19		
TOUBLESHOOTING	PAGE 20-21		
MACHINE PARTS	PAGE 22-40		

MACHINE INFORMATION

PLEASE FILL THIS AREA OUT AT THE TIME OF INSTALLATION FOR FUTURE REFERENCE.

MODEL NUMBER: _____

SERIAL NUMBER: _____

INSTALLATION DATE: _____

INSTALLING DEALER: _____

DEALER CONTACT: _____

ADDRESS: _____

CITY, STATE, ZIP: _____

PHONE NUMBER: _____

THIS OPERATOR AND PARTS MANUAL SHOULD BE CONSIDERED A PERMANENT PART OF THE UNIT AND SHOULD REMAIN WITH THE UNIT AT ALL TIMES. THIS OPERATOR AND PARTS MANUAL COVERS ALL THE TOMCAT 290/350 SERIES SCRUBBERS. YOU MAY FIND DESCRIPTIONS AND FEATURES THAT ARE NOT ON YOUR PARTICULAR MODEL. THE INFORMATION AND SPECIFICATIONS INCLUDED IN THIS PUBLICATION WERE IN EFFECT AT THE TIME OF PRINTING. MID-CENTRAL RESERVES THE RIGHT TO MAKE CHANGES WITHOUT NOTICE INCURRING ANY OBLIGATION.

TO REGISTER FOR WARRANTY, FAX YOUR WARRANTY REGISTRATION FORM TODAY!



R.P.S. CORPORATION
 P.O. BOX 368
 RACINE, WI 53401
 PHONE: 800-634-4060
 FAX 866-901-3335
 WWW.FACTORYCAT.COM

WARRANTY REGISTRATION FORM

COMPLETE FORM IMMEDIATELY AND FAX BACK TO (886)-901-3335

DEALER: _____ SERIAL NUMBER: _____
 LOCATION (CITY, STATE): _____ INSTALL DATE: _____
 CUSTOMER: _____ HOUR METER: _____
 CONTACT: _____ INSTALLED BY: _____
 ADDRESS: _____
 CITY: _____ STATE _____ ZIP _____
 PHONE: _____ FAX: _____

FACTORY CAT MODEL NUMBER: _____

OPTIONS: 1. _____ 4. _____
 2. _____ 5. _____
 3. _____ 6. _____

PADS: _____

BRUSHES: _____

SQUEEGEE SIZE: _____

BUYER'S REPRESENTATIVE HAS:

1. RECEIVED INSTRUCTION IN PROPER OPERATION OF THIS MACHINE.
2. RECEIVED OPERATOR'S MANUAL FOR THIS MACHINE.
3. BEEN MADE AWARE THAT ANY OPERATOR SHOULD READ THE MANUAL BEFORE OPERATING THIS MACHINE.

DEALER REP. PRINT: _____ SIGN: _____

CUSTOMER PRINT: _____ SIGN: _____

MODEL

290

350

BODY CONSTRUCTION/DIMENSIONS

TANK MATERIAL:

CHASSIS CONSTRUCTION:

REAR WHEELS:

FRONT WHEEL:

SIZE (L X W X H):

SQUEEGEE SIZE:

WEIGHT (WITHOUT BATTERIES):

WEIGHT (WITH BATTERIES):

POLY

3/16" STEEL

12" X 5"

12" X 4"

61" X 29"

32", 35", OR 38"

750 LBS.

1,260 LBS

POLY

3/16" STEEL

12" X 5"

12" X 4"

61" X 35"

35", 38", OR 45"

810 LBS.

1,320 LBS.

BRUSH/PAD SYSTEM

BRUSH/PAD DIAMETER (DISK):

DRIVE TO BRUSH (DISK):

SCRUBBING PATH (DISK):

BRUSH MOTOR POWER (DISK):

BRUSH MOTOR SPEED(DISK):

BRUSH SPEED (DISK):

BRUSH SIZE(CYLINDRICAL):

DRIVE TO BRUSH (CYLINDRICAL):

SCRUBBING PATH (CYLINDRICAL):

BRUSH MOTOR POWER (CYLINDRICAL):

BRUSH MOTOR SPEED (CYLINDRICAL):

BRUSH SPEED (CYLINDRICAL):

BRUSH DOWN PRESSURE:

BRUSH ADJUSTMENT:

(2) 15.5 INCHES

DIRECT

29 INCHES

(2) 1.0 HP

350 RPM

350 RPM

(2) 26 INCHES

CHAIN

26 INCHES

2.0 HP

800 RPM

800 RPM

0-200 LB.

(5) AUTOMATIC SETTINGS

(2) 18 INCHES

DIRECT

35 INCHES

(2) 1.0 HP

350 RPM

350 RPM

(2) 28 INCH OR (2) 32 INCH

CHAIN

28 INCHES OR 32 INCHES

2.0 HP

800 RPM

800 RPM

0-250 LB.

(5) AUTOMATIC SETTINGS

SOLUTION SYSTEM

SOL. TANK CAP:

SOLUTION FLOW RATE:

38 GAL

0-1.75 GPM

38 GAL

0-1.75 GPM

RECOVERY SYSTEM

REC. TANK CAP:

VACUUM POWER (STANDARD):

VACUUM POWER (OPTIONAL):

DRAIN HOSE:

CLEANOUT DOOR (OPTIONAL)

WATERLIFT:

40 GAL

1.0 HP

2.0 HP

2.0 INCHES

5.0 INCHES

70 INCHES

40 GAL

1.0 HP

2.0 HP

2.0 INCHES

5.0 INCHES

70 INCHES

BATTERY SYSTEM

BATTERY AH RATING:

BATTERY RUN TIME:

CHARGER (AUTOMATIC):

(4) 396 AH

UP TO 6 HRS.

36 AMP, 110 VOLT

(4) 396 AH

UP TO 6 HRS.

36 AMP, 110 VOLT

DRIVE SYSTEM

TRANSAXLE DESCRIPTION:

SPEED CONTROL:

BRAKING SYSTEM:

2.0 HP, SEALED

0-5 MPH

DYNAMIC BRAKING

2.0 HP, SEALED

0-5 MPH

DYNAMIC BRAKING

PRODUCTIVITY

SCRUBBING WIDTH:

SCRUBBING RATE/HOUR (NORMAL):

SCRUBBING RATE/HOUR (MAXIMUM):

29 INCHES

35,000 FT/HR

47,000 FT/HR

35 INCHES

45,000 FT/HR

58,000 FT/HR

WARRANTY

PARTS:

LABOR:

TANKS:

3 YEARS

1 YEAR

10 YEARS

3 YEARS

1 YEAR

10 YEARS

COMMON WEAR PARTS

<u>ITEM</u>	<u>MODEL</u> <u>290-D</u>	<u>MODEL</u> <u>290-C</u>	<u>MODEL</u> <u>350-D</u>	<u>MODEL</u> <u>350-C</u>
<u>BRUSH TYPE</u>	<u>DISK</u>	<u>CYLINDRICAL</u>	<u>DISK</u>	<u>CYLINDRICAL</u>

BRUSHES

SUPER-GRIT	15-421SS	NA	18-421SS	NA
TOUGH-GRIT	15-421S	25-521S	18-421S	32-521S
MIDI-GRIT	15-421C	25-521C	18-421C	32-521C
LIGHT-GRIT	15-421PS	25-521PS	18-421PS	32-521PS
POLY (.028)	15-421P	25-521P	18-421P	32-521P
NYLON (.016)	15-421N	25-521N	18-421N	32-521N
TAMPICO	15-421T	25-521T	18-421T	32-521T
PAD DRIVER	15-421D	NA	18-421D	NA

EXTRA PAD DRIVER RETAINING CLIP: 40-433

BRUSH REPAIR KIT: 40-423 REPLACEMENT LOCATING CLIP FOR ALL DISK BRUSHES

PADS

SUPER BLACK	15-422BB	NA	18-422BB	NA
BLACK	15-422B	NA	18-422B	NA
BROWN	15-422BR	NA	18-422BR	NA
GREEN	15-422G	NA	18-422G	NA
BLUE	15-422BL	NA	18-422BL	NA
RED	15-422R	NA	18-422R	NA
WHITE	15-422W	NA	18-422W	NA

SQUEEGEE KITS

<u>SIZE</u>	<u>GUM RUBBER</u>	<u>NEOPRENE</u>	<u>LINATEX</u>
32"	22-770G	22-770N	22-770L
35"	25-770G	25-770N	25-770L
38"	28-770G	28-770N	28-770L
45"	290-770G	290-770N	290-770L

KIT INCLUDES: (1) REAR BLADE, (1) FRONT BLADE, AND (2) BACKUP WHEELS WITH HARDWARE

NOTE: IT IS STAMPED INTO THE TOP OF THE SQUEEGEE BLANK, ON 32", 35", 38", AND 45" SQUEEGEES.

MODEL 290: HAS A 38" SQUEEGEE UNLESS OTHER SIZE IS SPECIALLY ORDERED AT TIME OF PURCHASE

MODEL 350: HAS A 45" SQUEEGEE UNLESS OTHER SIZE IS SPECIALLY ORDERED AT TIME OF PURCHASE

NOTE: THE 32" AND 35" SQUEEGEES ARE DESIGNED FOR NARROW ISLES AND MAY NOT HAVE THE SAME WATER CONTROL AROUND TIGHT TURNS AS THE LARGER SQUEEGEES.

SOAP

HEAVY DUTY DEGREASER

CITRUS

FREEZER

TIRE MARK REMOVER

CALL YOUR LOCAL DEALER FOR MORE SOAP INFORMATION

SAFETY MESSAGES

YOUR SAFETY, AND THE SAFETY OF OTHERS, IS VERY IMPORTANT, AND OPERATING THIS UNIT SAFELY IS AN IMPORTANT RESPONSIBILITY.

TO HELP YOU MAKE INFORMED DECISIONS ABOUT SAFETY, WE HAVE PROVIDED OPERATING PROCEDURES AND OTHER SAFETY INFORMATION IN THE MANUAL. THIS INFORMATION INFORMS YOU OF POTENTIAL HAZARDS THAT COULD HURT YOU OR OTHERS.

IT IS NOT PRACTICAL OR POSSIBLE TO WARN YOU OF ALL THE HAZARDS ASSOCIATED WITH OPERATING THIS UNIT. YOU MUST USE YOUR OWN GOOD JUDGEMENT.

THIS IS INTENDED FOR COMMERCIAL USE. IT IS DESIGNED TO BE USED ON HARD FLOORS IN AN INDOOR ENVIRONMENT, WITH THE RECOMMENDED PADS OR BRUSHES.

1. DO NOT OPERATE UNIT:

UNLESS TRAINED AND AUTHORIZED.
UNLESS OPERATOR MANUAL IS READ AND UNDERSTOOD.
IF UNIT IS NOT PROPER CONDITION.

2. WHEN OPERATING UNIT:

REMOVE LOOSE OBJECTS FROM THE FLOOR THAT MAY BE PROJECTED FROM THE REVOLVING BRUSHES.
KEEP HANDS AND FEET AWAY FROM REVOLVING BRUSHES.
DO NOT OPERATE MACHINE WHERE FLAMMABLE LIQUIDS ARE PRESENT.
USE EXTREME CAUTION WHEN MANUEVERING.

3. BEFORE LEAVING:

MAKE SURE MACHINE IS TURNED OFF.
STOP ON LEVEL SURFACES.
DISCONNECT BATTERIES.

4. BEFORE SERVICING:

STOP ON LEVEL SURFACE, AND SECURE MACHINE.
DISCONNECT BATTERIES.

!! SAFETY PRECAUTIONS!!

WARNING: HAZARDOUS VOLTAGE. SHOCK, BURNS OR ELECTROCUTION CAN RESULT. ALWAYS DISCONNECT THE BATTERIES BEFORE SERVICING MACHINE.

WARNING: BATTERIES EMIT HYDROGEN GASES, EXPLOSION OR FIRE CAN RESULT. KEEP SPARKS AND OPEN FLAMES AWAY.

WARNING: CHARGE UNIT IN A WELL VENTILATED AREA, AND KEEP BATTERY COMPARTMENT OPEN WHEN CHARGING. EXPLOSION OR FIRE COULD RESULT.

WARNING: BATTERY ACID CAN CAUSE BURNS. WEAR PROTECTIVE EYE WEAR AND GLOVES WHEN SERVICING BATTERIES.

WARNING: DO NOT STORE OUTDOORS OR PRESSURE WASH. PREVENT FROM GETTING ELECTRONIC COMPONENTS WET.

WARNING: THE USE OF PARTS AND SOLUTIONS OTHER THAN RECOMMENDED BY THE MANUFACTURER MAY CAUSE DAMAGE OR ENDANGER PEOPLE.

WARNING: DRESS SAFELY. DO NOT WEAR RINGS OR METAL WRIST WATCHES WHILE WORKING ON THIS MACHINE. THEY CAN CAUSE AN ELECTRICAL SHORT, WHICH, CAN CAUSE SERIOUS BURNS. DO NOT WORK ON THIS MACHINE WHILE WEARING A TIE, SCARF OR OTHER LOOSE, DANGLING NECKWARE OR CLOTHING. THESE LOOSE ITEMS CAN TANGLE IN THE ROTATING PARTS AND CAUSE SERIOUS INJURY OR EVEN DEATH.

WARNING: DO NOT USE THE MACHINE AS A STEP LADDER OR CHAIR.

WARNING: ONLY OPERATE THIS MACHINE FROM THE OPERATORS SEAT. IT WAS NOT DESIGNED TO CARRY PASSENGERS.

WARNING: DO NOT OPERATE THIS MACHINE ON RAMPS OR UNEVEN SURFACES. WHEN CLIMBING A RAMP, ALWAYS DRIVE THE MACHINE IN FORWARD STRAIGHT UP OR DOWN THE RAMP. NEVER DRIVE ACROSS THE INCLINE. DO NOT BACK DOWN OR TURN ON RAMPS!

WARNING: ALWAYS USE THE CHARGER PROVIDED BY THE MANUFACTURER TO CHARGE THE MACHINE. IT IS AN AUTOMATIC CHARGER, SPECIFICALLY DESIGNED TO CHARGE AT THE APPROPRIATE RATE. IF YOU MUST USE A DIFFERENT CHARGER, DISCONNECT THE BATTERIES BEFORE CHARGING. THIS WILL PREVENT DAMAGE TO THE ELECTRONIC SPEED CONTROLLER.

WARNING: UNDERSTAND THE DYNAMIC BRAKING SYSTEM BEFORE YOU OPERATE THE MACHINE ON RAMPS. MACHINE DOES NOT COAST. RELEASING THE FOOTPEDAL WILL AUTOMATICALLY APPLY BRAKING FORCE, AND STOP THE MACHINE.

WARNING: DO NOT PARK THE MACHINE ON RAMPS OR SLOPES. THE MACHINE HAS A PARKING BRAKE, BUT IT IS RECOMMENDED THAT IT IS ALWAYS PARKED ON LEVEL GROUND.

WARNING: DO NOT OPERATE THE MACHINE IF ANY PARTS HAVE BEEN REMOVED OR DAMAGED.

WARNING: DO NOT REMOVE, PAINT OVER, OR DESTROY WARNING DECALS. IF WARNING DECALS BECOME DAMAGED, THEY MUST BE REPLACED.

WARNING: DO NOT OPERATE MACHINE IN UNSAFE CONDITION. IF THE MACHINE IS IN NEED OF REPAIR OR IS IN ANY WAY UNSAFE TO OPERATE, THE MATTER SHOULD BE REPORTED IMMEDIATELY TO THE SHIFT SUPERVISOR. DO NOT OPERATE THE MACHINE UNTIL IT IS RETURNED TO PROPER OPERATING CONDITION.

WARNING: THIS MACHINE MUST ONLY BE OPERATED BY TRAINED OPERATOR. AS PART OF HIS OR HER TRAINING, THEY MUST READ THIS MANUAL THOROUGHLY. IF EXTRA COPIES ARE NEEDED, CONTACT YOUR LOCAL DEALER.

WARNING: ALWAYS TURN OFF THE MACHINE, BEFORE LEAVING IT UNATTENDED.

WARNING: DO NOT OPERATE OVER ELECTRICAL FLOOR OUTLETS. MAY RESULTS IN SERIOUS INJURY.

MACHINE CONTROLS AND FEATURES

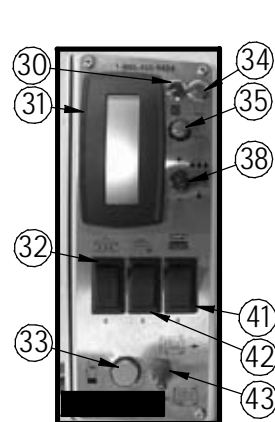
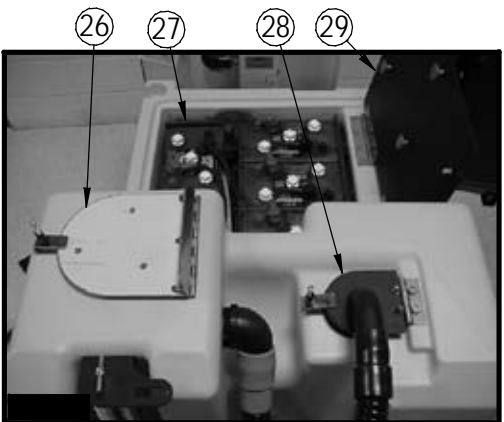
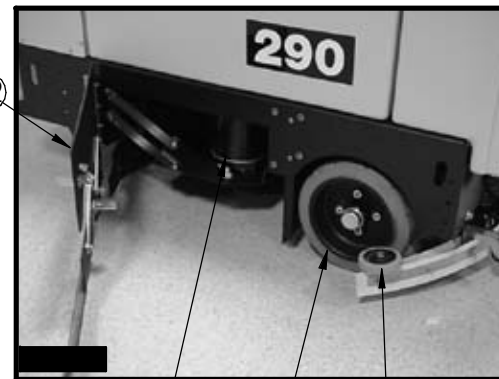
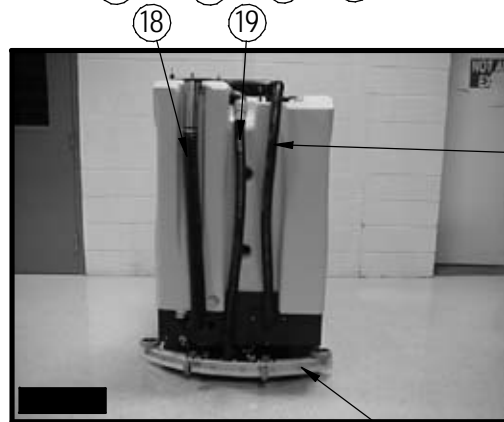
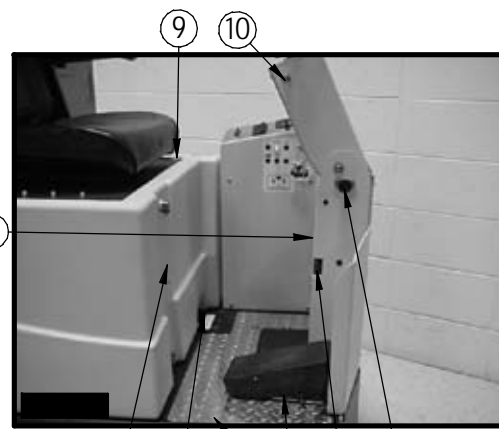
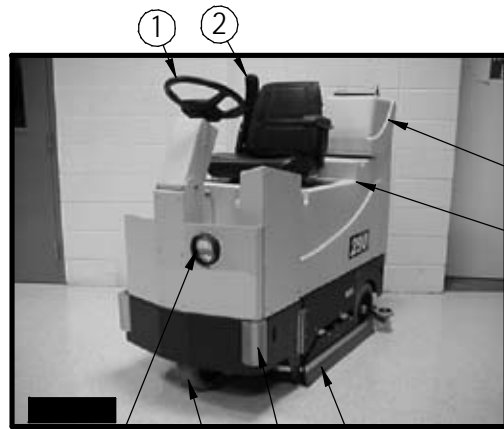

CONTROLS AND FUNCTIONS

SEE FIGURES (1-6B) ON PAGE 7

SEE FIGURE 1

1. STEERING WHEEL: STEERS THE MACHINE.
2. ADJUSTABLE SEAT WITH ARM RESTS: YOUR MACHINE IS EQUIPPED WITH AN ADJUSTABLE SEAT WITH ARM RESTS FOR COMFORT
3. RECOVERY TANK: HOLDS UP TO 40 GALLONS OF DIRTY WATER RECOVERED BY THE MACHINE.
4. SOLUTION TANK: HOLDS UP TO 38 GALLONS OF CLEAN WATER AND SOLUTION DETERGENT.
5. HEAD LIGHT: HELPS YOU SEE IN LOW LIGHT AREAS AND TO WARN ONCOMING TRAFFIC.
6. FRONT DRIVE WHEEL: DRIVES AND STEERS MACHINE.
7. BUMPER ROLLERS: HELPS PREVENT DAMAGE TO MACHINE AND OBJECTS THAT YOU MAY DRIVE CLOSE TO WHILE CLEANING.
8. DOOR WIPER: GOES UP AND DOWN WITH SCRUB DECK TO KEEP WATER FROM SPLASHING OUT OF MACHINE.

SEE FIGURE 2.

9. SEAT ADJUSTMENT: PERMITS THE SEAT TO BE ADJUSTED FORWARD AND BACKWARDS FOR OPERATORS COMFORT.
10. HORN BUTTON: SOUNDS THE HORN FOR WARNING ONCOMING TRAFFIC.
11. SOLUTION LEVEL INDICATOR: SHOWS OPERATOR THE PRECISE LEVEL OF CLEANING DETERGENT IN THE TANK.
12. SOLUTION FLOW CONTROL: USED TO MODULATE THE SOLUTION FLOW (GPM).
13. NON SLIP FLOOR PLATE: HELPS PREVENT SLIPPING WHILE GETTING ON AND OFF OF MACHINE.
14. FOOT PEDAL : CONTROLS THE ACCELERATION AND DECELERATION OF THE MACHINE.
15. CHARGER PORT: RED 50 USED TO RECEIVE CHARGER INPUT. NOTE: ONLY USE CHARGER PROVIDED.
16. ADJUSTABLE STEERING: FOUR SETTINGS FOR OPERATOR COMFORT AND EASE OF ENTRY.
17. CIRCUIT BREAKER: 50 AMP RESETABLE CIRCUIT BREAKER.

SEE FIGURE 3

18. RECOVERY DRAIN HOSE: ALLOWS FOR CONTROLLED DRAINING OF THE RECOVERY TANK.
19. VACUUM HOSE: VACUUMIZES SQUEEGEE . NOTE: KEEP FREE AND CLEAR OF BLOCKAGE.
20. VACUUM HOSE: MAIN VACUUM HOSE FROM VACUUM TO RECOVERY TANK.
21. SQUEEGEE BLADE: SQUEEGEES WATER TO BE RECOVERED BY THE VACUUM HOSE.

SEE FIGURE 4

22. SIDE DOOR: PROVIDES EASY ACCESS TO SCRUB DECK.
23. SCRUB DECK: MAIN COMPONENTS THAT SCRUB AND CLEAN FLOORS.
24. REAR WHEELS: NON MARKING REAR TIRES
25. SQUEEGEE BLADE PROTECTION WHEELS: HELP PROTECT THE SQUEEGEE WHEN CLEANING CLOSE TO OBJECTS.

SEE FIGURE 5

26. RECOVERY ACCESS DOOR: USED FOR FLUSHING OUT RECOVERY TANK WITH FRESH WATER.
27. BATTERIES: YOUR MACHINE IS EQUIPPED WITH FOUR (6 VOLT DEEP CYCLE 396 AMP HOUR BATTERIES)
28. FOAM PROTECTION SCREEN: USED TO PROTECT VACUUM MOTOR FROM DEBRIS.
29. BATTERY ACCESS LID: USED TO VENT BATTERIES DURING CHARGING, OR TO ACCESS BATTERIES FOR SERVICE.

SEE FIGURES 6A AND 6B

30. HIGH WATER RECOVERY LIGHT: INDICATES WHEN THE RECOVERY TANK IS NEARLY FULL.
31. LCD SCREEN: LISTS FUNCTIONS AND SETTING OF THE MACHINE. (SEE PAGES 17-19)
32. SQUEEGEE SWITCH: RAISES AND LOWERS THE SQUEEGEE.
33. ONE TOUCH BUTTON: ACTIVATES BRUSHES, SQUEEGEE, VACUUM SYSTEM, AND SOLUTION FLOW SIMUTANEOUSLY.
34. LOW WATER SOLUTION LIGHT: INDICATES WHEN THE SOLUTION TANK IS DOWN TO 5 GALLONS.
35. MENU CONTROL: SCROLLS THROUGH DIFFERENT OPTIONS ON THE LCD DISPLAY.
36. KEY SWITCH: TURNS THE MAIN POWER ON AND OFF.
37. OPTIONAL RECYLING SWITCH: TURNS ON THE RECYCLING PUMP. (GREEN)
38. SCRUB DECK DOWN PRESSURE SWITCH: CONTROLS THE PRESSURE PUT ON THE SCRUB DECK.
39. VACUUM WAND SWITCH: TURNS ON THE VACUUM MOTOR. (WHITE)
40. OPTIONAL SPRAY JET: TURNS ON THE SPRAY JET PUMP. (BLUE)
41. SCRUB DECK SWITCH: RAISES AND LOWERS THE SCRUB DECK.
42. SOLUTION SWITCH: OPENS AND CLOSES THE SOLUTION VALVE. GLOWS BLUE WHEN OPEN.
43. FORWARD/REVERSE SWITCH: CONTROLS THE DIRECTION OF THE TRACTION MOTOR. (RED)

MACHINE SETUP

UNCRATING MACHINE

CAREFULLY CHECK THE CRATE FOR ANY SIGNS OF DAMAGE. BATTERIES ARE IN THE UNIT.

TO UNCRATE THE MACHINE, REMOVE BANDING FROM AROUND THE CRATE. TAKE OFF THE TOP AND SIDES AND DISPOSE OF PROPERLY. REMOVE BANDING FROM MACHINE. REMOVE THE CHOCKS AROUND THE DRIVE WHEELS. FOLD DOWN RAMP, AND DRIVE MACHINE OFF OF THE BASE. NOTIFY THE CARRIER IMMEDIATELY IF CONCEALED DAMAGE IS DISCOVERED.

CONNECTING BATTERIES

YOUR MACHINE IS EQUIPPED WITH (FOUR) 6 VOLT, DEEP CYCLE, 396 AMP HOURS BATTERIES, WHICH FORM A 24 VOLT SYSTEM. MAXIMUM BATTERY DIMENSIONS ARE 7"W X 15"L X 15"H.

1. TURN ALL SWITCHES TO THE OFF POSITION AND REMOVE KEY.
2. HINGE OPEN THE BATTERY ACCESS LID TO ACCESS THE BATTERY COMPARTMENT.
3. ALL OF THE FOUR BATTERY CABLES ARE CONNECTED TO THE BATTERIES. LOCATE ANY LOOSE ONES AND CONNECT TO THE OPEN TERMINAL. TIGHTEN WITH 9/16" WRENCH. (SEE FIGURE 7.)
4. TURN ON MAIN POWER SWITCH AND CHECK THE BATTERY CONDITION METER TO ENSURE CORRECT INSTALLATION. CHARGE BATTERIES IF NEEDED. (SEE: BATTERY CHARGING)

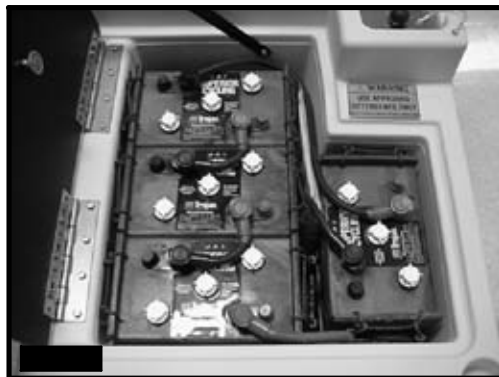

ATTACHING SQUEEGEE

1. LOWER THE SQUEEGEE MOUNTING PLATE BY DEPRESSING THE SQUEEGEE SWITCH TO THE DOWN POSITION. (SEE FIGURE 8.)



2. LOOSEN THE TWO WING NUTS ON THE SQUEEGEE AND SLIDE THEM INTO THE SLOTS IN THE SQUEEGEE MOUNTING PLATE. THE SQUEEGEE TRAIL WHEELS SHOULD FACE OUTWARD. (SEE FIGURE 9.)
3. TIGHTEN THE TWO WINGNUTS, AND CONNECT VACUUM HOSE FROM THE MACHINE TO THE SQUEEGEE. (SEE FIGURE 9.)
4. YOU MAY HAVE TO ADJUST THE SQUEEGEE PITCH, BY USING THE PITCH ADJUSTMENT. (SEE FIGURE 9.)

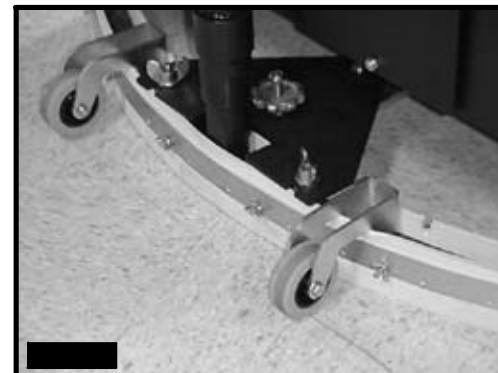

ATTACHING DISK BRUSHES

1. TURN ON MACHINE POWER
2. RAISE THE SCRUB DECK BY DEPRESSING THE BRUSH SWITCH TO THE UP AND OFF POSITION AND TURN MACHINE POWER BACK OFF. (SEE FIGURE 10.)



3. OPEN SIDE DOOR TO ACCESS SCRUB DECK
4. SELECT THE CORRECT PADS OR BRUSHES THAT BEST MEET YOUR CLEANING APPLICATION. CONSULT YOUR LOCAL DEALER FOR ASSISTANCE.
5. PAD INSTALLATION ATTACH PADS TO PAD DRIVERS BEFORE CONNECTING DRIVERS TO MOTOR HUB.
6. ATTACH BRUSHES OR PADS TO MOTOR HUBS. SQUEEZE THE SCISSOR LOCKING DEVICE AND LIFT BRUSH UP ON TO THE MOTOR DRIVE HUB. MAKE SURE THE SCISSORS CLOSE AND LOCK ONCE THE BRUSHES ARE ON. (SEE FIGURE 11.)

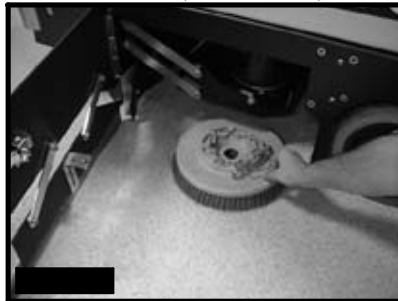

7. LIFT UP ON THE WIPERS FIRST TO CLOSE SIDE DOOR AND DEPRESS THE LATCH UNTIL THE DOOR IS SECURED. (SEE FIGURE 12.)



ATTACHING CYLINDRICAL BRUSHES

1. TURN ON MACHINE POWER
2. RAISE THE SCRUB DECK BY DEPRESSING THE BRUSH SWITCH TO THE UP AND OFF POSITION AND TURN MACHINE POWER BACK OFF. (SEE FIGURE 10.)
3. OPEN THE SIDE DOOR TO ACCESS CYLINDRICAL SCRUB DECK
4. UNSCREW THE THREE WINGNUTS ON THE BRUSH ACCESS DOOR AND REMOVE THE DOOR. (SEE FIGURE 13.)

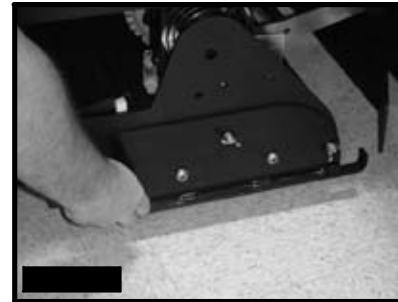

5. SLIDE THE BRUSHES IN ONE AT A TIME. WHEN YOU GET THE BRUSH ON THE DRIVER SPIN IT WITH YOUR HAND UNTIL YOU FEEL IT ENGAGE AND DROP IN. (SEE FIGURE 14.)



6. WHEN BOTH BRUSHES ARE ENGAGED REPLACE THE BRUSH ACCESS DOOR AND TIGHTEN IT BACK DOWN WITH THE WINGNUTS. (SEE FIGURE 15.)



7. LIFT UP ON THE WIPERS FIRST TO CLOSE SIDE DOOR AND DEPRESS THE LATCH UNTIL THE DOOR IS SECURED. (SEE FIGURE 12.)

FOR CORRECT PAD APPLICATION, CALL YOUR LOCAL DEALER

OPERATION

PRE-CLEANING CHECK LIST

READ AND UNDERSTAND THE SAFETY SECTION ON PAGE 5 AND 6 BEFORE OPERATING MACHINE.

1. CHECK BATTERY CONDITION GAUGE ON THE CENTRAL COMMAND II LCD SCREEN. TO CHECK GAUGE PUSH MENU CONTROL BUTTON UNTIL BATTERY GAUGE APPEARS. MAKE SURE BATTERIES ARE FULLY CHARGED BEFORE USING.
2. CHECK THE CONDITION OF PADS OR BRUSHES.
3. CHECK THE CONDITION OF THE SQUEEGEE BLADES.
4. TRANSPORT THE MACHINE TO THE FILLING STATION. RAISE THE SCRUBHEAD AND SQUEEGEE WHEN TRANSPORTING.
5. TURN MACHINE OFF.
6. OPEN SOLUTION FILL DOOR AT THE SIDE OF THE MACHINE AND FILL THE TANK WITH UP TO 38 GALLONS OF CLEAN WATER. THE CLEAR TUBE AT THE FRONT OF THE MACHINE INDICATES THE AMOUNT OF WATER IN THE TANK.
7. ADD CLEANING CHEMICAL. USE THE PROPER DILUTION RATIO INDICATED ON THE BOTTLE.

NOTE: USE ONLY NONFLAMMABLE COMMERCIAL CLEANING CHEMICALS. YOUR AUTHORIZED DISTRIBUTOR CAN ASSIST YOU IN SELECTING A PROPER CHEMICAL.



ONE PASS SCRUBBING

STEPS: (SEE FIGURE 17.)

1. TURN MACHINE ON WITH THE KEY SWITCH.
2. LOWER SQUEEGEE BY PRESSING THE SWITCH.
3. LOWER SCRUB HEAD TO THE FLOOR, USE THE TOP HALF (+) OF THE BRUSH SWITCH.
4. TURN ON THE SOLUTION SWITCH AND ADJUST THE SOLUTION LEVER TO THE DESIRED SETTING.
5. BEGIN SCRUBBING BY DEPRESSING THE FOOT PEDAL SLOWLY AND THEN TO THE SPEED REQUIRED, THE HEADLIGHT SHOULD ILLUMINATE.
6. ONCE THE MACHINE BEGINS TO MOVE, CHECK THE DOWN PRESSURE GAUGE. START SCRUBBING AT THE #1 OR # 2 MARKS, DO NOT USE THE #4 OR #5 MARKS WITHOUT MANAGER'S APPROVAL.
7. TO OPERATE MACHINE IN REVERSE, SIMPLY SWITCH THE REVERSE SWITCH TO THE REVERSE POSITION, BACK UP ALARM MAY SOUND AND YOUR REV SPEED IS SET TO ROUGHLY 50% OF FORWARD.
8. TO STOP THE MACHINE, LET OFF OF THE FOOT PEDAL, AND THE MACHINE WILL STOP AUTOMATICALLY.

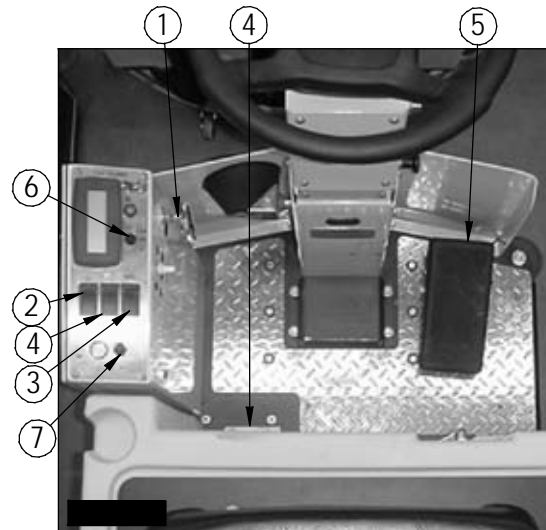

OPERATING HINTS

1. OBSERVE THE AMOUNT OF SOLUTION THE MACHINE IS DISPENSING ON THE FLOOR AND ADJUST TO THE DESIRED FLOW. TO INCREASE THE SOLUTION FLOW RATE, MOVE THE SOLUTION LEVER TO THE OPERATORS RIGHT. TO SHUT THE SOLUTION OFF COMPLETELY, USE THE SWITCH, OR JUST RELEASE THE FOOT PEDAL.
2. KEEP AN EYE ON THE REC FULL LIGHT TO MAKE SURE THERE IS NOT FOAMY BUILDUP IN THE RECOVERY TANK. IF EXCESS FOAM BEGINS TO DEVELOP, POUR A RECOMMENDED FOAM CONTROL SOLUTION INTO THE RECOVERY TANK. FOAM IS USUALLY AN INDICATION OF EXCESSIVE SOAP.
3. ALWAYS OPERATE AT LOWER SPEEDS WHEN SCRUBBING AROUND WALLS AND OBJECTS. YOU SHOULD REDUCE THE SPEED, TO MAINTAIN CONTROL WHEN TURNING.
4. IF SQUEEGEE STARTS TO STREAK, RAISE AND WIPE THE BLADES WITH A CLEAN CLOTH. IF THE PROBLEM CONTINUES, CHECK THE BLADES FOR WEAR OR DAMAGE, AND ROTATE IF NEEDED. YOU NEED TO PRESWEEP BEFORE SCRUBBING.
5. CHANGE OR TURN OVER PADS WHEN DIRTY. ROTATE THE SCRUB BRUSHES EVERY WEEK.
6. STAY CLEAR OF OBJECTS PROTRUDING FROM THE FLOOR, SUCH AS SOCKETS, GRATES, DIES, FOR THEY WILL DAMAGE THE PADS AND SQUEEGEE BLADES.
7. DURING BRIEF STOPS YOU DO NOT HAVE TO TURN ANYTHING OFF, THE BRUSHES AND SOLUTION WILL AUTOMATICALLY STOP WHEN THE FOOT PEDAL IS RELEASED.
8. ALWAYS KEEP AN EYE ON YOUR GAUGES. THEY LET YOU KNOW THE STATUS OF A PARTICULAR SYSTEM AT A GLANCE. IF YOUR BATTERY GAUGE IS READING LOW, YOU MUST STOP IMMEDIATELY, AND RECHARGE. RUNNING THE BATTERIES DEAD, WILL RESULT IN DAMAGE TO THE BATTERIES. EXCESSIVE SCRUBBING PRESSURE WILL BLOW A BREAKER.
9. WHEN YOU RUN OUT OF SOLUTION, RAISE THE BRUSHES, AND CONTINUE TO VACUUM THE REMAINING WATER UNTIL IT IS CONSUMED. THE SOLUTION SIGHT HOSE IS USED TO INDICATE THE LEVEL OF DETERGENT REMAINING IN THE TANK.
10. WHEN YOU ARE READY TO STOP, PICK UP THE BRUSHES, TURN OFF THE SOLUTION SWITCH, PICK UP THE SQUEEGEE, AND DRIVE THE MACHINE BACK TO THE CHARGING AREA. BE SURE TO DRAIN BOTH TANKS BEFORE STORING MACHINE.

DRAINING RECOVERY TANK

ALWAYS EMPTY RECOVERY TANK WHEN REFILLING THE SOLUTION TANK. TO DRAIN THE RECOVERY TANK, PERFORM THE FOLLOWING STEPS.

1. REMOVE DRAIN HOSE FROM THE EXPANSION PLUG HOLDER BY TUNING THE T-HANDLE COUNTER CLOCKWISE. OPEN THE TOP "RECOVERY ACCESS LID" AND FLUSH OUT WITH WATER TO KEEP TANK CLEAN. (SEE FIGURE 18.)

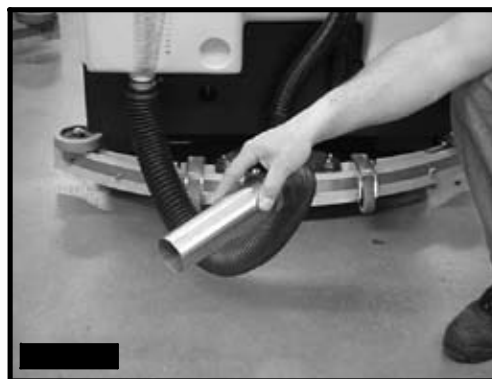

2. RINSE THE RECOVERY TANK AFTER EVERY USE. THIS WILL PREVENT HEAVY BUILDUP ON THE BOTTOM OF THE TANK, FOUL ODORS, AND CLOGGING OF THE DRAIN HOSE.
3. ONCE TANK IS EMPTY, PUT DRAIN HOSE BACK ON THE PLUG AND TIGHTEN BY TURNING THE T-HANDLE CLOCK WISE.

DRAINING SOLUTION TANK

TO DRAIN LEFT OVER CLEANING SOLUTION FROM THE SOLUTION TANK, PERFORM THE FOLLOWING STEPS. (SEE FIGURE 19.)

1. ROTATE THE BLUE SOLUTION TANK DRAIN VALVE OUTWARDS.

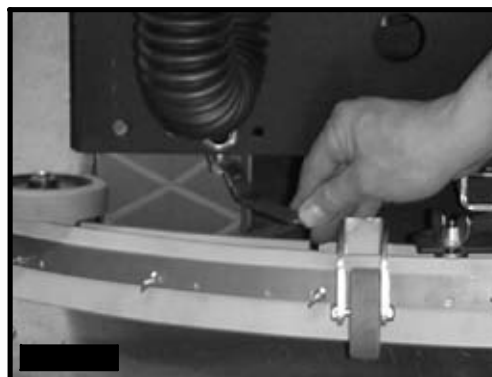

BATTERY CHARGING

CAUTION: THE FOLLOWING INSTRUCTIONS ARE INTENDED FOR THE 24V CHARGER SUPPLIED WITH THE MACHINE. DO NOT USE ANY OTHER CHARGER WITH THIS MACHINE.

CHARGER SPECIFICATIONS

OUTPUT VOLTAGE OF 24 VOLTS.

OUTPUT CURRENT OF 36 AMPS MAX.

INPUT VOLTAGE OF 110 VOLTS/60 HZ.

AUTOMATIC SHUT OFF CIRCUIT.

MADE FOR DEEP CYCLE BATTERIES.

DANGER: ALWAYS CHARGE BATTERIES IN A WELL VENTILATED AREA. BATTERIES EMIT HYDROGEN GAS. EXPLOSION OR FIRE CAN RESULT. KEEP SPARKS AND FLAME AWAY. SHIELD EYES WHEN SERVICING BATTERIES AND AVOID CONTACT WITH BATTERY ACID. LEAVE ACCESS PANEL OPEN WHEN CHARGING!

1. TRANSPORT MACHINE TO A WELL VENTILATED AREA FOR CHARGING.
2. TURN THE MACHINE OFF.
3. HINGE OPEN THE BATTERY ACCESS PANEL TO EXPOSE THE BATTERIES. (SEE FIGURE 20.) (CAUTION ALWAYS WEAR EYE PROTECTION WHEN BATTERIES ARE EXPOSED)

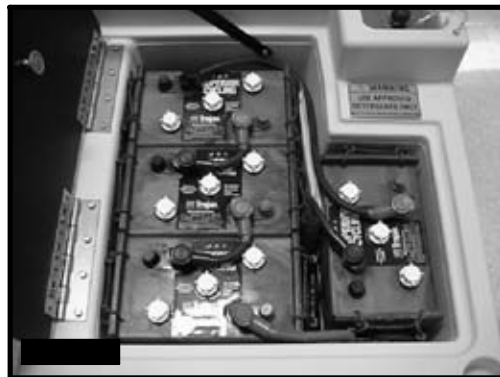

4. CHECK THE WATER LEVEL IN EACH BATTERY. DO NOT CHARGE THE MACHINE UNLESS THE WATER IS SLIGHTLY HIGHER THAN THE PLATES. IF NEEDED, ADD ENOUGH *DISTILLED* WATER TO JUST SLIGHTLY COVER THE PLATES. DO NOT OVER FILL. BATTERIES CAN OVERFLOW DURING CHARGING. REPLACE CAPS BEFORE CHARGING.
5. WITH THE RED CHARGER PLUG DISCONNECTED FROM THE MACHINE, PLUG THE CHARGER POWER CORD INTO A GROUNDED 110 VOLT STANDARD WALL OUTLET. (SEE FIGURE 21.)
6. CONNECT THE RED CHARGER PLUG INTO THE BATTERY CHARGING PORT LOCATED ON THE LOWER PORTION OF THE STEERING TOWER.



7. THE CHARGER WILL AUTOMATICALLY BEGIN CHARGING, AND AUTOMATICALLY SHUT OFF WHEN FULLY CHARGED (CHECK GAUGE)
8. AFTER THE CHARGER HAS TURNED OFF, UNPLUG THE RED CHARGER PLUG FROM THE MACHINE AND DISCONNECT THE CHARGER FROM THE WALL OUTLET.
9. RECHECK THE CELL LEVEL AFTER CHARGING. IF NEEDED, ADD DISTILLED WATER UP TO THE CORRECT LEVEL. BE CERTAIN TO REPLACE THE CAPS SECURELY AND TO WIPE OFF THE TOP OF THE BATTERIES WITH A CLEAN CLOTH.

MAINTENANCE

DAILY MAINTENANCE

1. REMOVE AND CLEAN PADS OR BRUSHES. NEVER USE SOILED PADS WHEN CLEANING. REPLACE PADS WHEN THEY BECOME PACKED WITH RESIDUE.
2. REMOVE AND CLEAN DEBRIS FROM THE FLOAT SHUT-OFF SCREEN LOCATED INSIDE THE RECOVERY TANK.
3. DRAIN AND RINSE TANKS THOROUGHLY INSPECT VACUUM HOSE FOR ANY OBJECTS OBSTRUCTING THE AIR FLOW.
4. RAISE SQUEEGEE AND WIPE BLADES WITH A CLEAN CLOTH. STORE SQUEEGEE IN THE RAISED POSITION TO PREVENT DAMAGE OR SETTING OF THE BLADES.
5. WIPE DOWN MACHINE IF NEEDED. USE A NONABRASIVE, NON SOLVENT CLEANER, OR A CLEAN DAMP CLOTH.
6. RECHARGE THE BATTERIES IF NEEDED.

WEEKLY MAINTENANCE

1. CHECK BATTERY WATER LEVEL IN EACH CELL OF THE BATTERIES, AND FILL AS NEEDED. ALWAYS USE DISTILLED WATER TO REFILL BATTERIES. BATTERIES SHOULD BE FILLED APPROXIMATELY 3/4" TO 1" ABOVE THE PLATES. OVERFILLING WILL CAUSE THE BATTERIES TO LEAK DURING CHARGING. THE CHARGING PROCESS CREATES GAS BUBBLES INSIDE THE BATTERY, WHICH EFFECTIVELY INCREASES THE VOLUME OF THE ELECTROLITE.
2. CLEAN BATTERY TOPS TO PREVENT CORROSION.
3. ROTATE BRUSHES. ROTATE THE LEFT TO THE RIGHT AND RIGHT TO LEFT. ON CYLINDRICAL MODELS FROM FRONT TO BACK, OR END TO END IF USING DIFFERENT MATERIALS.

MONTHLY MAINTENANCE

1. CHECK SCRUB HEAD AND SQUEEGEE LIFTING CABLES FOR WEAR AND SPRING TENSION.
2. CHECK MACHINE FOR WATER LEAKS AND LOOSE NUTS AND BOLTS.
3. CHECK TO SEE IF BATTERY CABLES ARE TIGHTENED (TIGHTEN IF NEEDED)
4. CHECK PARKING BRAKE
5. CHECK CONDITION OF SCRUB DECK LIFTING CABLE.

YEARLY MAINTENANCE

1. CALL YOUR LOCAL DEALER FOR YEARLY MAINTENANCE

STORING MACHINE

1. BE SURE TO FLUSH THE TANKS OUT COMPLETELY, AND TO DRAIN ALL WATER FROM THE MACHINE.
2. REMOVE THE RECOVERY TANK LID TO PROMOTE AIR CIRCULATION.
3. RAISE BRUSHES AND SQUEEGEE.

PREVENTATIVE MAINTENANCE RECORDS

USE THIS FORM TO MAKE COPIES FOR YOUR INTERNAL RECORDS

<u>PREVENTATIVE MAINTENANCE</u>	<u>CHECKED</u>	<u>NOTE</u>
ROTATE BRUSHES	_____	_____
ROTATE SIDE BROOMS	_____	_____
DRAIN SOLUTION TANK	_____	_____
FLUSH SOLUTION SYSTEM	_____	_____
CLEAN SOLUTION SCREEN	_____	_____
DRAIN RECOVERY TANK	_____	_____
FLUSH RECOVERY TANK	_____	_____
CLEAN VACUUM SCREEN	_____	_____
ROTATE REAR SQUEEGEE BLADE	_____	_____
CHECK BATTERY WATER LEVEL	_____	_____
CHECK BATTERY VOLTAGE	_____	_____
CHECK CHARGER CONDITION	_____	_____
CHECK BATTERY CONNECTIONS	_____	_____
CHECK CHEMICAL LEVEL	_____	_____
CHECK MACHINE PERFORMANCE	_____	_____
SCRUBBING POWER	_____	_____
VACUUM POWER	_____	_____
CONTROLS WATER ON TURNS	_____	_____
GAUGES AND CONTROLS	_____	_____
CHECK WHEEL TRACTION	_____	_____
OTHER: _____	_____	_____
OTHER: _____	_____	_____
PAST HOUR METER READING:		_____
CURRENT HOUR METER READING:		_____
AVERAGE WEEKLY USAGE:		_____
TECHNICIAN PRINT: _____		
TECHNICIAN SIGNATURE: _____		DATE: _____
MANAGER SIGNATURE: _____		DATE: _____

PREVENTATIVE MAINTENANCE RECORDS

USE THIS FORM TO MAKE COPIES FOR YOUR INTERNAL RECORDS

<u>PREVENTATIVE MAINTENANCE</u>	<u>CHECKED</u>	<u>NOTE</u>
ROTATE BRUSHES	_____	_____
ROTATE SIDE BROOMS	_____	_____
DRAIN SOLUTION TANK	_____	_____
FLUSH SOLUTION SYSTEM	_____	_____
CLEAN SOLUTION SCREEN	_____	_____
DRAIN RECOVERY TANK	_____	_____
FLUSH RECOVERY TANK	_____	_____
CLEAN VACUUM SCREEN	_____	_____
ROTATE REAR SQUEEGEE BLADE	_____	_____
CHECK BATTERY WATER LEVEL	_____	_____
CHECK BATTERY VOLTAGE	_____	_____
CHECK CHARGER CONDITION	_____	_____
CHECK BATTERY CONNECTIONS	_____	_____
CHECK CHEMICAL LEVEL	_____	_____
CHECK MACHINE PERFORMANCE	_____	_____
SCRUBBING POWER	_____	_____
VACUUM POWER	_____	_____
CONTROLS WATER ON TURNS	_____	_____
GAUGES AND CONTROLS	_____	_____
CHECK WHEEL TRACTION	_____	_____
OTHER: _____	_____	_____
OTHER: _____	_____	_____
PAST HOUR METER READING:		_____
CURRENT HOUR METER READING:		_____
AVERAGE WEEKLY USAGE:		_____
TECHNICIAN PRINT: _____		
TECHNICIAN SIGNATURE: _____		DATE: _____
MANAGER SIGNATURE: _____		DATE: _____

LCD SCREEN MENU DISPLAYS

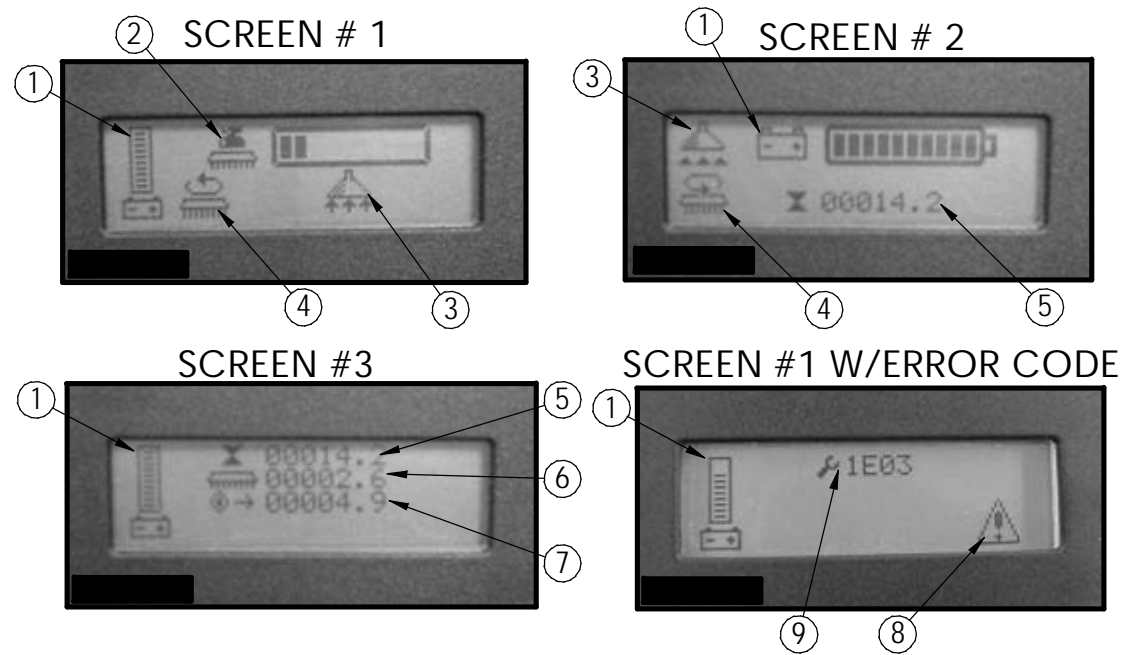

*** USE GREEN MENU SELECTION BUTTON ON CONTROL PANEL TO CHANGE SCREENS***

FIGURES 22-25.

1. BATTERY LEVEL INDICATOR - INDICATES THE ENERGY LEVEL REMAINING IN THE BATTERIES. (SHOWN ON ALL MENU DISPLAYS)
2. SCRUBBING DECK DOWN PRESSURE GAUGE - SETS THE DOWN PRESSURE ON THE BRUSHES. (SEE FIGURE 22.)
3. VACUUM ON - TELLS YOU WHEN THE VACCUM IS ON. (SEE FIGURES 22. AND 23)
4. SCRUBBING MOTORS ON - TELLS YOU WHEN THE BRUSH MOTORS ARE RUNNING. (SEE FIGURES 22. AND 23.)
5. KEY SWITCH HOUR METER - TELLS YOU THE TOTAL HOURS THE MACHINE HAS ON. (SEE FIGURES 23. AND 24.)
6. SCRUBBING BRUSH HOUR METER - TELLS YOU THE TOTAL HOURS THE BRUSH MOTORS HAVE BEEN USED. (SEE FIGURE 24.)
7. TRANSPORT HOUR METER - TELLS YOU THE TOTAL HOURS THE DRIVE SYSTEM HAS BEEN USED. (SEE FIGURE 24.)
8. ERROR WARNING SYMBOL - INDICATES WHEN THERE HAS BEEN A DIAGNOSTIC CODE ERROR. (SEE FIGURE 25.)
9. DIAGNOSTIC CODE - WHEN THE MACHINE HAS DETECTED AN ERROR IT WILL DISPLAY THE WARNING SYMBOL AND A DIAGNOSTIC CODE WHICH TELL YOU WHATS WRONG. (SEE FIGURE 25.)

(FOR COMMAND ERROR CODES AND DISCRPTIONS SEE PAGE 18. AND 19.)

TROUBLESHOOTING CENTRAL COMMAND

NOTE: THIS MACHINE IS OPERATED BY A SOPHISTICATED ELECTRONIC "BRAIN" THAT HAS MANY FAIL-SAFES WITHIN IT. THE BRAIN SELF-ANALYZES PROBLEMS AND FLASHES A FOUR-DIGIT NUMERIC CODE OF WHAT IS WRONG IN THE LCD WINDOW.

MOST OF THESE CODES REQUIRE A TECHNICIAN'S ATTENTION. YOU SHOULD NOT ATTEMPT REPAIRS YOU ARE UNCOMFORTABLE WITH, ESPECIALLY IF YOU ARE NOT USED TO WORKING ON ELECTRONICS.

THE COMPLETE LIST OF CODES IS PUBLISHED IN THE *SIMPLIFIED ELECTRONIC TROUBLESHOOTING MANUAL*, WHICH IS AVAILABLE TO TECHNICAL PEOPLE. HOWEVER, WE HAVE INCLUDED THE BASIC CODES THAT YOU CAN USUALLY RESOLVE YOURSELF.



1. 1E03 AND 1E04 ERROR. CHECK THE SMALL SAFETY SWITCH NEXT TO THE RED PLUG BELOW THE DASHBOARD. THIS SWITCH WILL TURN OFF THE TRACTION DRIVE AND BRUSHES AS A SAFETY FEATURE WHILE THE CHARGER IS PLUGGED IN. THE SWITCH MAY BE STUCK, OR THE PLUG TWISTED AT AN ANGLE, ENGAGING THE SWITCH. THIS CODE WILL ALSO FLASH IF THE WIRING BECOMES VERY WET. IN THIS CASE, EITHER WAIT UNTIL THE WIRING DRIES OUT, OR CALL A TECHNICIAN.

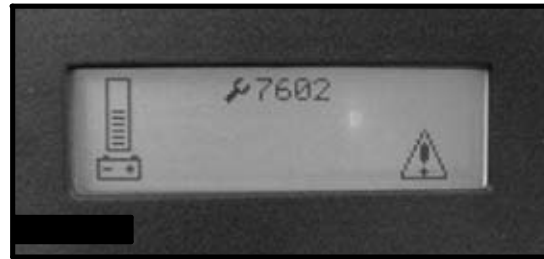

2. 7601 AND 7602 ERROR. PAD CURRENT OVER LOAD. THIS CAN OCCUR WHEN THE PADS HIT A BUMP IN THE FLOOR. TO RESTART THE PADS, TURN OFF THE KEY AND TURN IT ON AGAIN. TO AVOID THIS ERROR, EITHER SLOW DOWN ON BUMPY PARTS OF THE FLOOR, OR REDUCE DOWNPRESSURE ON THE PADS.



3. 1600 ERROR. VOLTAGE EXCEEDS THE MAXIMUM. EITHER THE BATTERIES ARE MIS-WIRED, OR THE CHARGER IS STILL PLUGGED INTO THE MACHINE.



4. 7700, 7701, 7702, AND 7703 ERROR. THE VACUUM MOTOR HAS EXCEEDED THEIR AUTHORIZED POWER LIMITS. TURN OFF KEY AND TURN ON AGAIN TO CLEAR.

TROUBLESHOOTING CENTRAL COMMAND



5. 7900 AND 7901 ERROR. THE EMERGENCY STOP BUTTON IS OUT

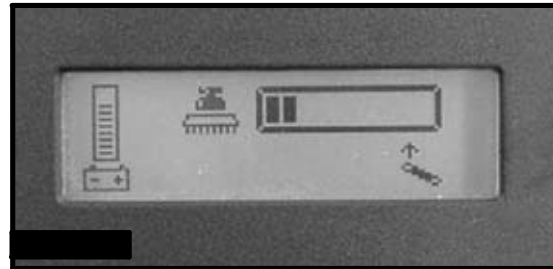

6. 2FO1 ERROR. YOU PRESSED THE FOOT PEDAL BEFORE TURNING ON THE KEY. TURN OFF THE KEY AND TRY AGAIN, LEAVING FOOT OFF OF THE PEDAL.



7. 2C00 AND 2C01 ERROR. LOW VOLTAGE WARNING. VOLTAGE HAS DROPPED DOWN BELOW THE MINIMUM REQUIRED TO OPERATE THE MACHINE. IF YOU WAIT A FEW MINUTES, THE BATTERIES MAY COAST UP A BIT IN VOLTAGE, ALLOWING YOU TO DRIVE VERY SLOWLY TO THE RECHARGE STATION. IF NOT, YOU WILL HAVE TO RELEASE THE PARKING BRAKE (ON THE FRONT WHEEL, PULL LEVER TOWARD THE FRONT OF THE MACHINE TO RELEASE) AND PUSH THE MACHINE TO RECHARGING STATION.



8. 7802 ERROR. THE TRACTION MOTOR WAS USED TO CLIMB A RAMP, AND WAS RUNNING UP THE RAMP FOR MORE THAN THE 60 SECONDS ALLOWED FOR THIS. TURN OFF THE KEY, TURN ON AGAIN, AND CONTINUE. YOU SHOULD NOT USE THIS MACHINE TO CLIMB RAMPS SO STEEP AND SO LONG THAT THIS CODE COMES UP REPEATEDLY, OR YOU COULD OVERHEAT THE TRACTION MOTOR.

9. ALL OTHER ERROR CODES. TURN OFF THE KEY, AND DISCONNECT THE POSITIVE BATTERY CABLE FROM THE BATTERIES FOR MORE THAN ONE MINUTE (THE TIME IS NEEDED TO DRAIN THE BRAIN'S ON-BOARD CAPACITOR). RECONNECT CABLES, BEING SURE THAT IT IS TIGHT. TOO LOOSE AND YOU WILL BURN BATTERY. IF YOU OVERTIGHTEN THE CABLES YOU CAN DAMAGE THE BATTERY'S LEAD TERMINAL. TRY AGAIN.

10. IF THE PROBLEMS CANNOT BE SOLVED BY ANY OF THESE SOLUTION CALL YOUR LOCAL DEALER'S SERVICE DEPARTMENT.

TROUBLE SHOOTING

<u>PROBLEM</u>	<u>CAUSE</u>	<u>SOLUTION</u>
NO POWER, NOTHING OPERATES	FAULTY KEY SWITCH BATTERIES NEED CHARGING FAULTY BATTERY LOOSE BATTERY CABLE MAIN CIRCUIT BREAKER TRIPPED	CONTACT LOCAL SERVICING DEALER SEE CHARGING BATTERIES REPLACE BATTERY TIGHTEN LOOSE CABLE WAIT 5 MINUTES FOR AUTO RESET DETERMINE CAUSE AND CORRECT
BRUSH MOTOR(S) DO NOT OPERATE	BRUSH DECK IS NOT DOWN FOOT PEDAL IS NOT DEPRESSED BRUSH CIRCUIT BREAKER TRIPPED CARBON BRUSHES WORN FAULTY BRUSH MOTOR OR WIRES	PUT BRUSH DECK DOWN ENGAGE FOOT PEDAL WAIT 5 MINUTS FOR AUTO RESET DETERMINE CAUSE AND CORRECT CONTACT LOCAL SERVICING DEALER CONTACT LOCAL SERVICING DEALER
DRIVE MOTOR DOES NOT OPERATE	RECHARGE SWITCH MISADJUSTED FAULTY SPEED CONTROLLER OR WIRES FAULTY DRIVE MOTOR FAULTY WIRING CARBON BRUSHES WORN	CONTACT LOCAL SERVICING DEALER CONTACT LOCAL SERVICING DEALER CONTACT LOCAL SERVICING DEALER CONTACT LOCAL SERVICING DEALER CONTACT LOCAL SERVICING DEALER
VACUUM MOTOR DOES NOT OPERATE	SQUEEGEE IS IN THE UP POSITION FAULTY VACUUM SWITCH VACUUM CIRCUIT BREAKER TRIPPED FAULTY VACUUM MOTOR CARBON BRUSHES WORN	ROTATE SQUEEGEE LIFT LEVER DOWN TRY OPERATING "WHITE " TOGGLE WAIT 5 MINUTES FOR AUTO RESET DETERMINE CAUSE AND CORRECT CONTACT LOCAL SERVICING DEALER CONTACT LOCAL SERVICING DEALER
DRIVE MOTOR RUNS INCORRECTLY	FAULTY SPEED CONTROLLER OR WIRES FAULTY POTENTIOMETER LOOSE WIRES	CONTACT LOCAL SERVICING DEALER CONTACT LOCAL SERVICING DEALER CONTACT LOCAL SERVICING DEALER
INSUFFICIENT SOLUTION FLOW	SOLUTION TANK LOW FLOW KNOB TURNED DOWN SOLUTION FILTER CLOGGED SOLUTION LINE CLOGGED SOLUTION VALVE CLOGGED	REFILL SOLUTION TANK, DRAIN RECOVERY TANK MOVE LEVER TO ON REMOVE COVER AND CLEAN REMOVE AND BLOW OUT WITH COMPRESSED AIR REMOVE COVER AND CLEAN

TROUBLE SHOOTING

<u>PROBLEM</u>	<u>CAUSE</u>	<u>SOLUTION</u>
NO SOLUTION FLOW	NO SOLUTION IN TANK SOLUTION VALVE OFF SOLUTION SWITCH OFF SOLUTION SCREEN CLOGGED FAULTY SOLUTION SOLENOID FAULTY SOLUTION SWITCH	FILL SOLUTION TANK ROTATE LEVER TO ON TURN SOLUTION SWITCH ON REMOVE AND CLEAN SCREEN CONTACT LOCAL SERVICING DEALER CONTACT LOCAL SERVICING DEALER
POOR WATER RECOVERY	RECOVERY TANK IS FULL BALL/SCREEN IN RECOVERY TANK IS CLOGGED VACUUM HOSE IS CLOGGED SQUEEGEE IS CLOGGED SQUEEGEE BLADE IS WORN FAULTY VACUUM HOSE VACUUM MOTOR GASKET TORN TANK GASKET FAULTY DRAIN PLUG LOOSE VAC MOTOR FAULTY BATTERY CHARGE LOW	EMPTY RECOVERY TANK REMOVE SCREEN AND CLEAN REMOVE DEBRIS REMOVE DEBRIS ROTATE OR REPLACE BLADES CONTACT LOCAL SERVICING DEALER CONTACT LOCAL SERVICING DEALER CONTACT LOCAL SERVICING DEALER TIGHTEN LID CONTACT LOCAL SERVICING DEALER CHARGE BATTERIES OVERNIGHT
POOR WATER RECOVERY ON TURNS	WIPERS WORN WIPERS CHATTER SQUEEGEE SWING IS BINDING INCORRECT SQUEEGEE SIZE	REPLACE WIPER MATERIAL TIGHTEN PIVOT POINTS CONTACT LOCAL SERVICING DEALER CONTACT LOCAL SERVICING DEALER
REAR TIRES NOISY	BEARING DRY FAULTY HUBS	GREASE BEARINGS CONTACT LOCAL SERVICING DEALER
POOR TRACTION	EXCESSIVE BRUSH PRESSURE WORN DRIVE TIRE HEAVY SOAP CONCENTRATION	REDUCE PRESSURE WITH SWITCH CONTACT LOCAL SERVICING DEALER
SHORT RUN TIME	BATTERIES RUN DOWN BATTERIES STILL DOWN BATTERIES LOW ON WATER BATTERIES OVER CYCLED	CHARGE BATTERIES TWICE CONTACT LOCAL SERVICING DEALER FILL WITH DISTILLED WATER TO 3/4" ABOVE THE LEAD PLATES CONTACT LOCAL SERVICING DEALER

MODEL 290/350

MACHINE PARTS SECTION

SOME PARTS ARE MADE IN RED AND YELLOW. IF YOU NEED YELLOW PARTS USE THE ALTERNATE PART NUMBER WHICH WILL START WITH (291-XXXX). IF YOU NEED RED PARTS, USE THE NORMAL PART NUMBER THAT WILL START WITH (290-XXXX). IF THERE IS ONLY ONE PART NUMBER, THAT IS THE ONLY COLOR THAT PART COMES IN.

SOLUTION SYSTEM

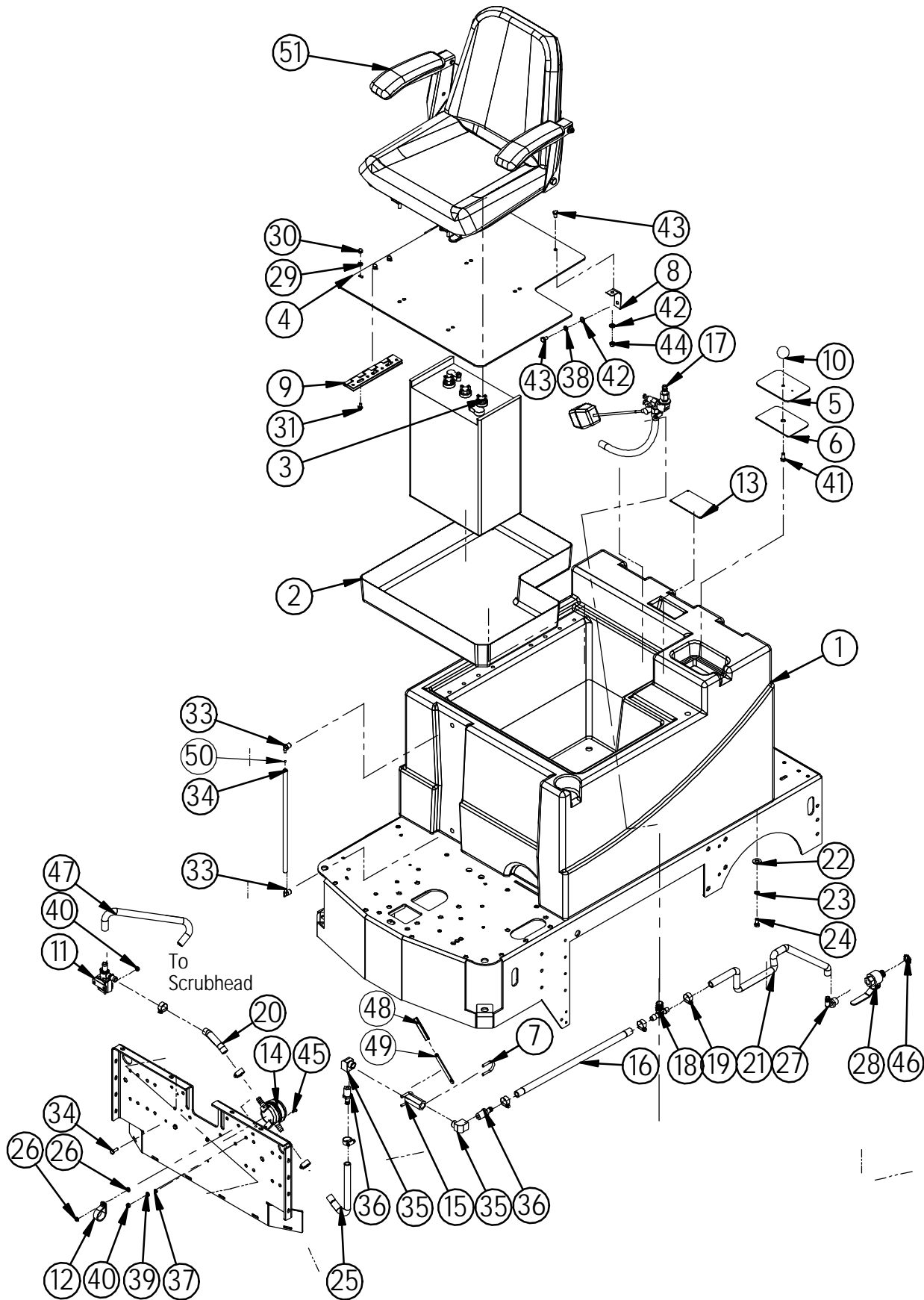

SOLUTION SYSTEM

Item	Part No.	Alt. Part No.	Part Description	Qty
1	290-4140	291-4140	SOLUTION TANK	1
2	290-1480		BATTERY TRAY	1
3	290-2110		BATTERY 6 VOLT 395 AH	4
4	290-1300		BATTERY COMP'T COVER	1
5	290-4152		SOLUTION TANK LID	1
6	290-4153		SOL TANK LID GASKET	1
7	H-01519		1/4-20 X 1.75 " U BOLT	2
8	290-4151		LID STRAP	1
9	5-122		HINGE 8" SS	2
10	21-7101		LIFT KNOB	1
11	21-4500		ADJUSTABLE SOLUTION FLOW VALVE	1
12	H-3225T5		RUBBER LOOP CLAMP	1
13	5-728		DETERGENT WARNING PLATE	1
14	5-913		INLINE FILTER	1
15	290-4158		1/2" NPT BALL VALVE	1
16	290-4175		1/2" ID X 3/4" OD X 28.0" LG CLEAR TUBE	1
17	290-8520		FLOAT VALVE ASSEMBLY	1
18	290-4155		1/2" NPT X 1/2" BARBED TEE	1
19	H-081		CLAMP 7/16" - 25/32" SS	7
20	290-4160		1/2" ID X 3/4" OD X 5.0" LG CLEAR TUBE	1
21	290-4164		1/2" ID X 3/4" OD X 24.0" LG CLEAR TUBE	1
22	H-99001		FW 3/8" SS	6
23	H-71065		LW 5/16" SS	6
24	H-70053		HCS 5/16" - 18 X 3/4" SS	6
25	290-4159		1/2" ID X 3/4" OD X 15.0" LG CLEAR TUBE	1
26	H-NJ04C		JNYL 1/4" - 20 SS	2
27	5-447		1/2" NPT TO 1/2" BARBED ELBOW	1
28	290-4550		1/2" NPT BALL VALVE	1
29	H-33618		LW 1/4"	4
30	H-37708		1/4-20 LC ACORN NUT	4
31	H-13001		HCS 1/4" - 20 X 1/2"	3
32	290-4150		1/4" ID X 1/2" OD X 14" LG CLEAR TUBE	1
33	290-4149		1/4" NPT X 1/4" BARB X 90 DEG	2
34	H-70003		HCS 1/4" - 20 X 3/4" SS	2
35	21-4042		1/2" NPT X 90 DEG ST ELBOW	2
36	290-4176		.50 NPT X .50 BARB	2
37	H-70858		NYLOK #10-32 SS	2
38	H-33620		LW 5/16"	1
39	H-71063		LW 1/4" SS	1
40	H-70710		HN 1/4" - 20 SS	3
41	H-13053		HCS 5/16" - 18 X 3/4"	1
42	H-33080		FW 5/16" SAE	2
43	H-13051		HCS 5/16" - 18 X 1/2"	2
44	H-37021		NYLOK 5/16" - 18	1
45	H-72563		RPH #10-32 X 1/2" SS	2
46	H-07005		1/2" NPT LOCKNUT	1
47	290-4174		1/2" ID X 3/4" OD X 19.0" LG CLEAR TUBE	1
48	290-7721		LEVER GRIP	1
49	290-7720		BALL VALVE LEVER	1
50	290-4148		7/32" POLYPROPYLENE BALL	1
51	8-143		SEAT WITH ARM RESTS	1

RECOVERY SYSTEM

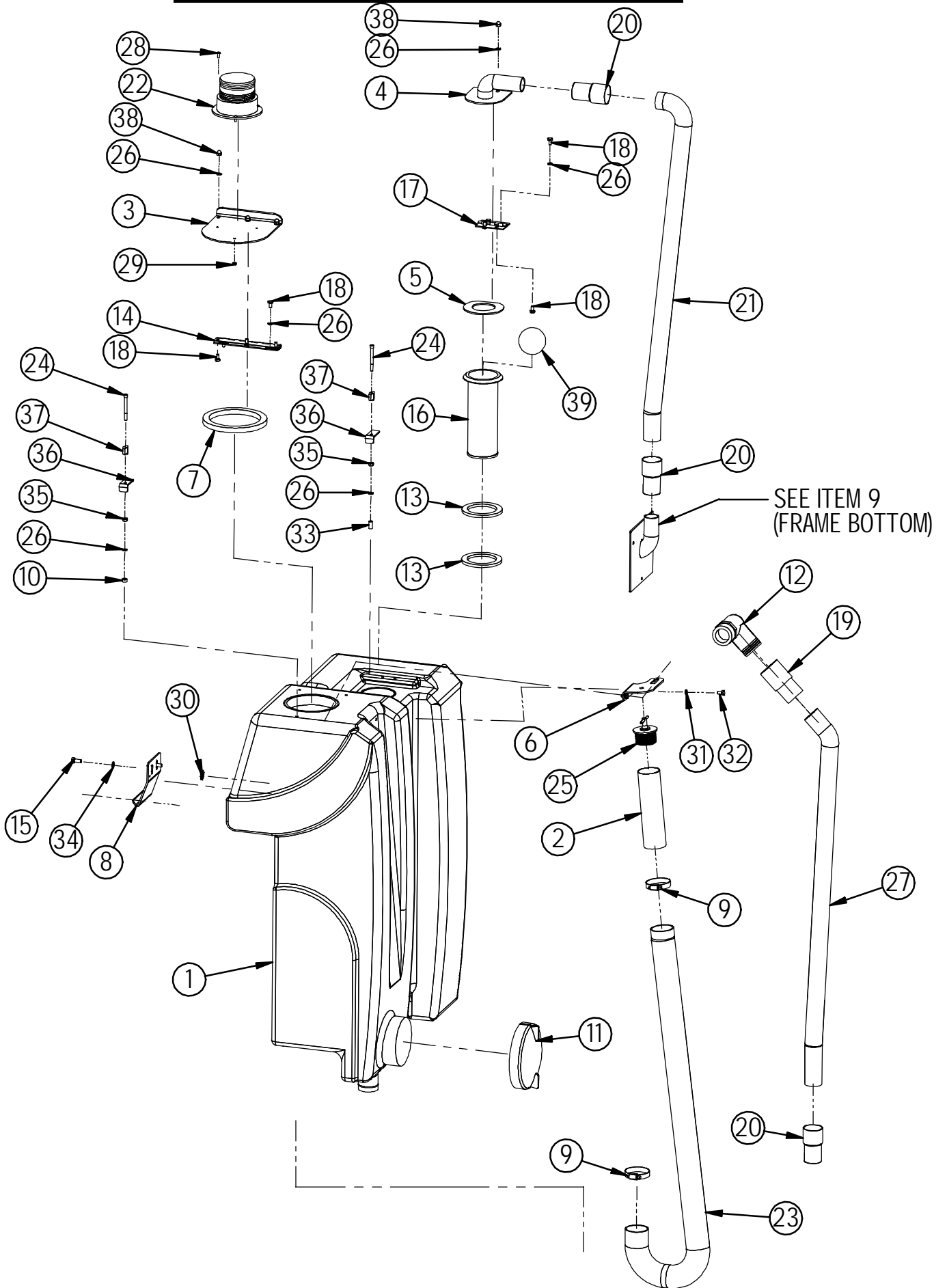

SEE ITEM 9
(FRAME BOTTOM)

RECOVERY SYSTEM

Item	Part No.	Alt. Part No.	Part Description	Qty
1	290-7010	291-7010	RECOVERY TANK	1
2	5-920		DRAIN HOSE END TUBE	1
3	290-4112		RECOVERY TANK LID	1
4	290-4110		VAC SCREEN INLET	1
5	290-7390		VAC INLET GASKET	1
6	5-7180		DRAIN HOSE BRACKET	1
7	290-7420		REC TANK LID GASKET	1
8	290-1120		FRONT TANK SUPPORT	1
9	5-719		CLAMP 1 9/16 - 2 1/2 " SS	2
10	21-2211		SPACER 1/2 OD X 1/4"	1
11	7-415		CLEANOUT DOOR W/GASKET & DISC	1
12	290-7040		RECOVERY TANK ELBOW	1
13	38-738		STRAINER GASKET	2
14	8-180		6-7/8" SS HINGE	1
15	H-13053		HCS 5/16"-18 X 3/4"	2
16	8-911		SCREEN STRAINER	1
17	290-4115		VAC INLET HINGE	1
18	H-13001		HCS 1/4"- 20 X 1/2"	9
19	290-7212		1-1/2" - 2" HOSE CUFF	1
20	21-4072		HOSE CUFF, 1 1/2"	3
21	290-7213		VAC HOSE 37" LG	1
22	8-293		STROBE LIGHT	1
23	290-7210		DRAIN HOSE	1
24	H-23213		SHCS 1/4"- 20 X 2 1/2"	2
25	5-727		DRAIN HOSE PLUG	1
26	H-33618		LW 1/4"	11
27	290-7214		VAC HOSE 40" LG	1
28	H-73743		BHSCS 10-32 X 1/2" SS	3
29	H-70858		NYLOK #10-32 SS	3
30	H-33761		5/16" INT/EXT STAR WASHER	1
31	H-71063		LW 1/4" SS	2
32	H-70001		HCS 1/4"-20 X 1/2 SS"	2
33	5-822		Spacer, 1/4" ID, 3/8" OD, 11/16" Long	1
34	H-33620		LW 5/16"	2
35	H-36102		HN 1/4"-20	2
36	5-417		DOOR CLIP	2
37	5-418A		CLAMPING KNOB	2
38	H-37708		1/4-20 LC ACORN NUT	5
39	38-712		OVERFILL SHUTOFF BALL	1

FRAME TOP

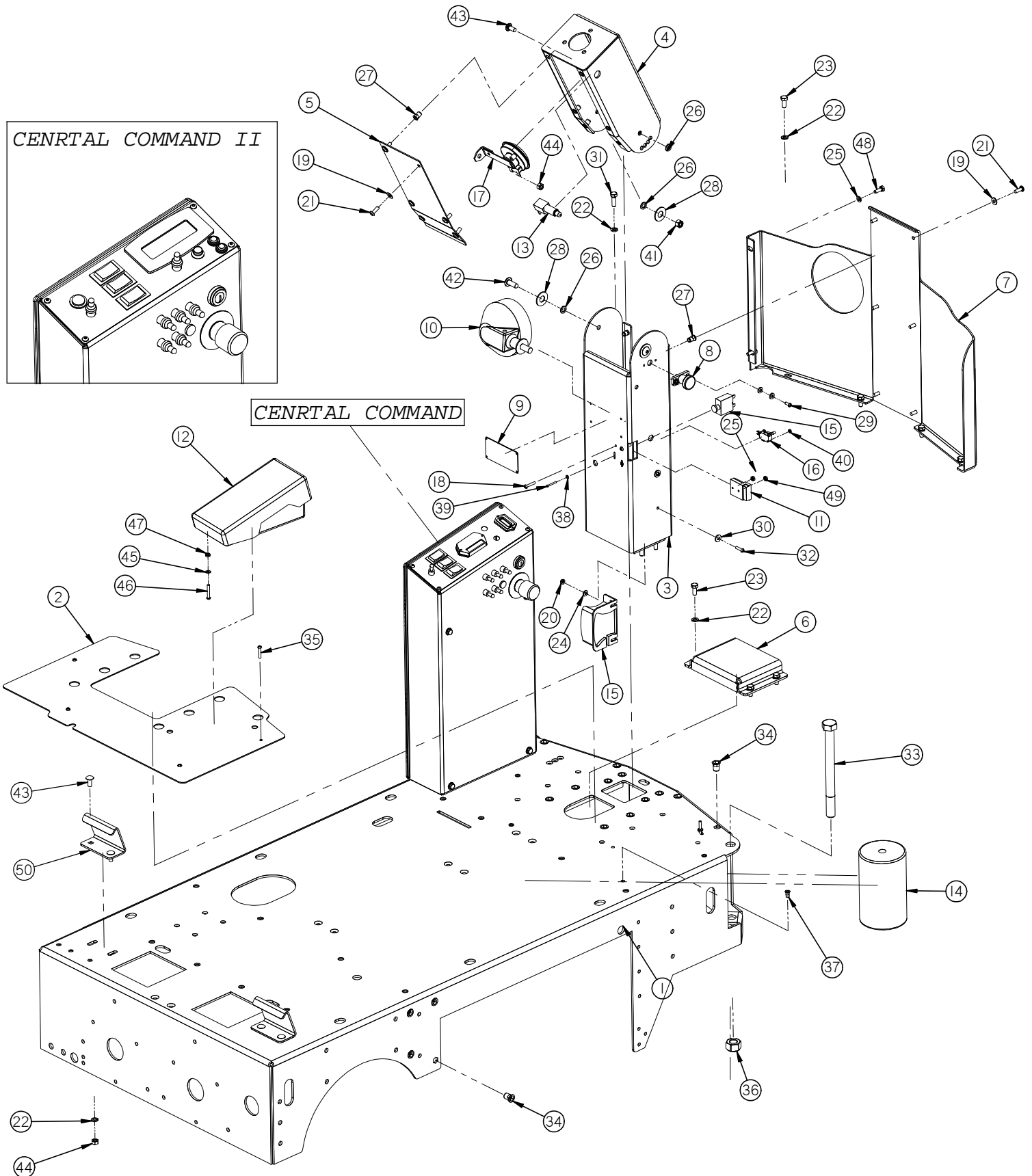
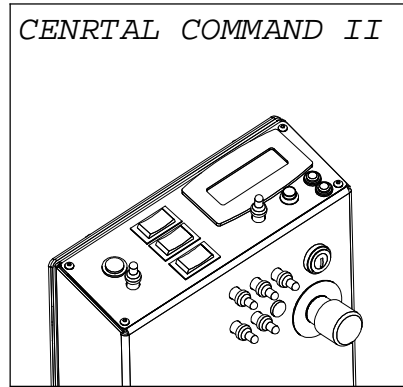

FRAME TOP

Item	Part No.	Alt. Part No.	Part Description	Qty
1	290-1100		FRAME WELDMENT	1
2	290-1610		NON SKID FLOOR PLATE	1
3	290-1170	291-1170	LOWER STEERING TOWER	1
4	290-1171	291-1171	UPPER STEERING TOWER	1
5	290-1172	291-1172	COVER	1
6	290-1173		DRIVE COVER	1
7	290-1180	291-1180	FRONT APRON	1
8	290-7050		INDEX PLUNGER	1
9	4-101		SERIAL NUMBER PLATE	1
10	8-291		HEADLIGHT	1
11	4-257		CONNECTOR, RED 50, WITH CONTACTS	1
12	8-290		FOOT PEDAL	1
13	8-294B		PUSH BUTTON SWITCH, SILVER	1
14	7-125A		ROLLER	2
15	8-292		BACKUP ALARM	1
16	21-2230		MICRO SWITCH	1
17	8-294		HORN	1
18	H-28902		RPH #8-32 X 1"	2
19	H-76061		FW 1/4" NYLON	12
20	H-37015		NYLOK #10-32	2
21	H-73754		BHSCS 1/4 - 20 X 3/4" SS	12
22	H-33620		LW 5/16"	16
23	H-13053		HCS 5/16"-18 X 3/4"	8
24	H-33074		FW #10 SAE	6
25	H-71063		LW 1/4" SS	2
26	H-76063		FW 3/8" NYLON	6
27	H-250HCN		HCN 1/4"-20	8
28				4
29	H-29048		RPH #10-32 X 1/2"	2
30	H-71009		FW #10 SS	2
31	H-13055		HCS 5/16"-18 X 1"	4
32	H-72565		RPH #10-32 X 3/4" SS	2
33	H-11380		HCS 3/4-10 X 8-1/2	2
34	H-312HCN		HCN 5/16"-18	25
35	H-29072		RPH #10-32 X 1"	4
36	H-37039		NYLOK 3/4"- 10	2
37	H-1032HCN		HCN #10-32	4
38	H-33066		FW #4 SAE	2
39	H-28678		RPH #4-40 X 1"	2
40	H-37006		NYLOK #4-40	2
41	H-37024		NYLOK 3/8"-16	2
42	H-73815		BHSCS 3/8"- 16 X 1" SS	2
43	H-21253		CB 5/16"- 18 X 3/4"	5
44	H-36104		HN 5/16"-18	5
45	H-71009		FW 3/16" X 7/16" SS	2
46	H-73747		RPH #10-32 X 1 1/4" SS	2
47	H-70858		NYLOK #10-32 SS	2
48	H-70003		HCS 1/4"- 20 X 3/4" SS	2
49	H-37406		KN #8-32	2
50	290-1115		BOTTOM LATERAL TANK LOCATOR	2

FRAME BOTTOM

NOTE:
SPLASH CURTAINS ARE
USED ON DISK MACHINES ONLY.

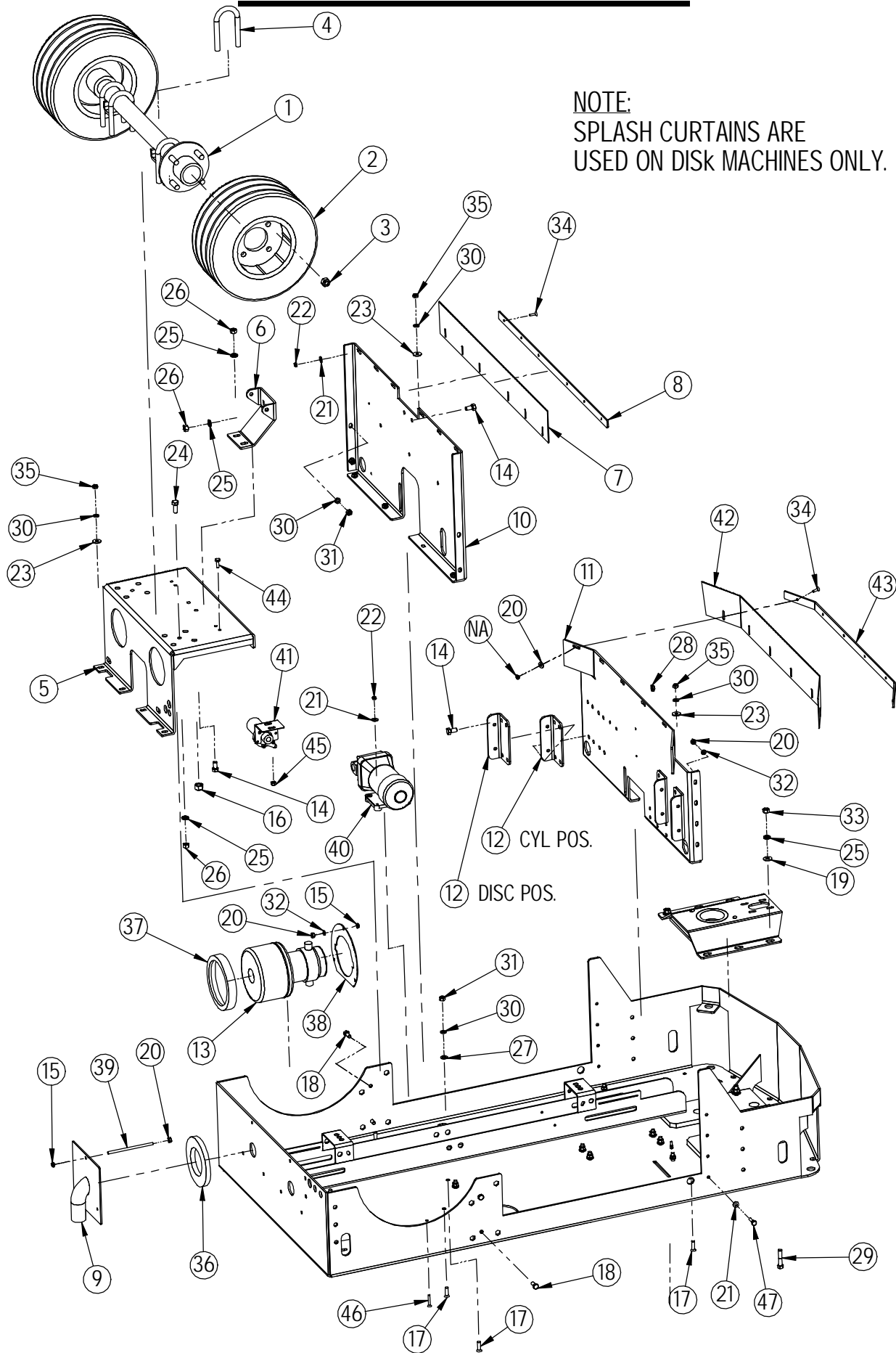

FRAME BOTTOM

Item	Part No.	Alt. Part No.	Part Description	Qty
1	290-6040		REAR AXLE	1
2	290-6180	290-6185	REAR WHEEL (GREY STD.) (BLACK OPT.)	2
3	290-6187		LUG NUT, 1/2" - 20	1
4	290-6186		1/2-13 X 1-1/4 " U BOLT	4
5	290-5000		AXLE MOUNT	1
6	290-5001		SQUEEGEE DRAG BRACE	1
7	290-1253		REAR SPLASH CURTAIN	1
8	290-1254		REAR CURTAIN MTG STRIP	1
9	290-3003		VAC INLET ASS'Y	1
10	290-1250		REAR SPLASH GUARD	1
11	290-1260		FRONT SPLASH GUARD	1
12	290-1265		SCRUB ARM BRACKET	4
13	5-225		VAC MOTOR	1
14	H-70103		HCS 3/8"-16 X 3/4" SS	20
15	H-NJ04C		JNYL 1/4" - 20 SS	9
16	H-37130		NYLOK NUT, 1/2" - 20	8
17	H-29598		FPH 5/16" - 18 X 1"	17
18	H-13053		HCS 5/16"-18 X 3/4"	4
19	H-71017		FW 3/8" SS	3
20	H-70710		HN 1/4" - 20 SS	20
21	H-71013		FW 1/4" X 5/8" SS	12
22	H-70858		NYLOK #10-32 SS	8
23	H-71016		FW 5/16" X 7/8" USS	12
24	H-70105		HCS 3/8" - 16 X 1" SS	2
25	H-71067		LW 3/8" SS	10
26	H-70712		HN 3/8"-16 SS	6
27	H-33080		FW 5/16" SAE	8
28	H-0129158		JNYL 3/8- 16 SS	16
29	H-70145		HCS 3/8" - 24 X 1 3/4" SS	4
30	H-33620		LW 5/16"	21
31	H-70861		NYLOK 5/16" - 18 SS	9
32	H-71063		LW 1/4" SS	14
33	H-70732		HN 3/8"- 24 SS	4
34	H-72684		FHP 10-32 X 3/4" SS	12
35	H-NJ05C		JNYL 5/16"- 18 SS	12
36	290-3001		VAC BOX GASKET	1
37	5-708A		VAC MOTOR GASKET	1
38	38-734		BLOWER RING	1
39	H-00221		FTS 1/4" - 20 X 5" SS	1
40	5-891		PUMP, WATER JET	1
41	290-8500		PUMP 24V DC (OPTIONAL)	1
42	290-1310		FR. SPLASH CURTAIN - SHORT	1
	290-1315		FR. SPLASH CURTAIN - LONG	
43	290-1320		CURTAIN MTG STRIP - SHORT	1
	290-1325		CURTAIN MTG STRIP - LONG	
44	H-70003		HCS 1/4"- 20 X 3/4" SS	8
45	H-70860		NYLOK 1/4"- 20 SS	4
46	H-72686		FHP 10-32 X 1-1/4" SS	4
47	H-70005		HCS 1/4" - 20 X 1" SS	4
48	H-71009		FW #10 SS	6

DOOR/WIPER/ROLLER ASSEMBLY

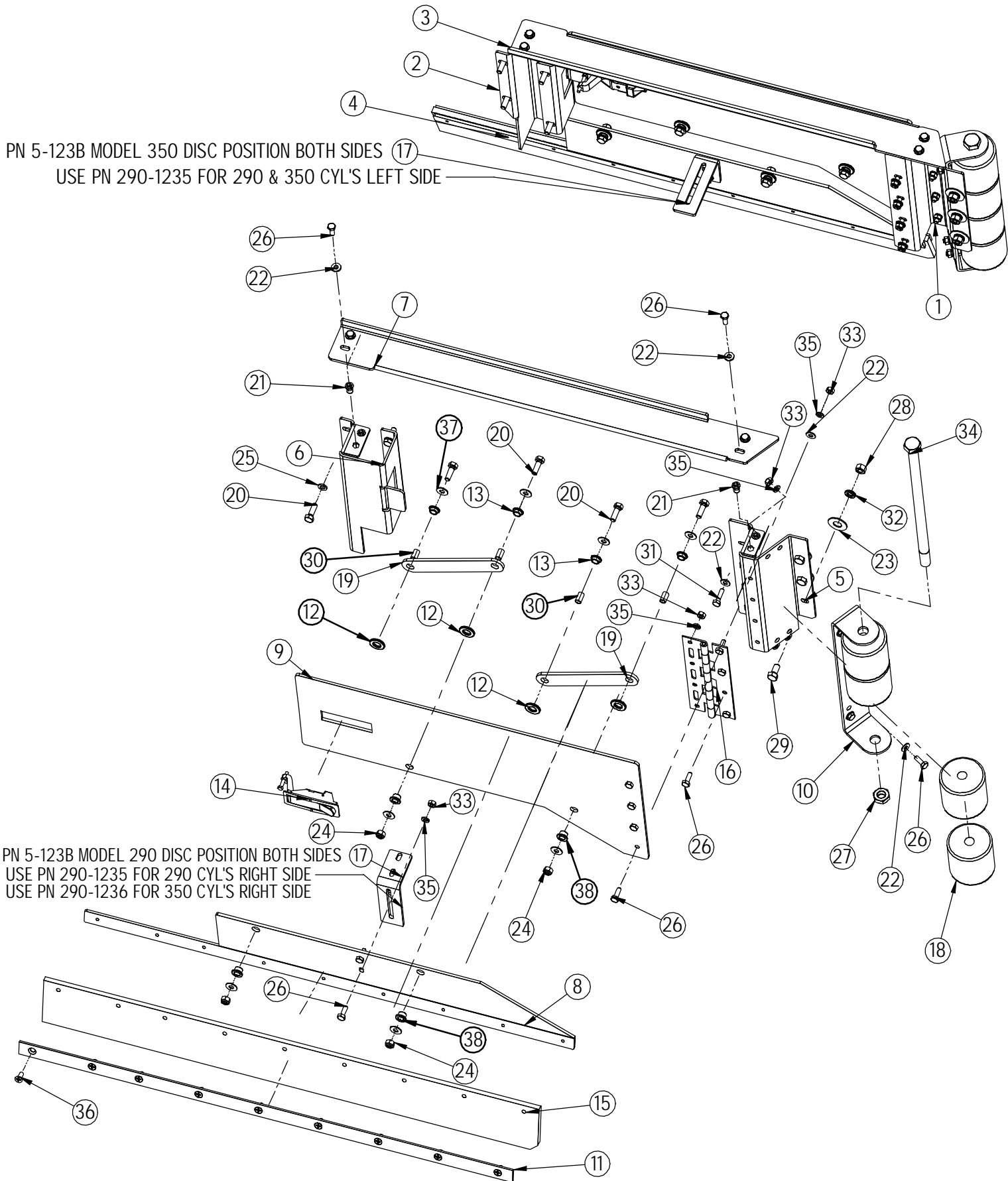

DOOR/WIPER/ROLLER ASSEMBLY

Item	Part No.	Part Description	Qty
1	290-1270	FRONT LH POD	1
2	290-1280	REAR LH POD	1
3	290-1290	LH POD TOP SUPPORT	1
4	290-1230	LEFT WIPER	1
5	290-1271	FRONT RH POD	1
6	290-1281	REAR RH POD	1
7	290-1291	RH POD TOP SUPPORT	1
8	290-1231	RIGHT WIPER	1
9	290-1220	DOOR	2
10	290-1126	ROLLER BRACKET	2
11	290-4030	WIPER BAND	2
12	290-1248	FW BRONZE .500 ID X 1.00 OD X .125 THK	8
13	290-1243	3/8" ID, 1/2" OD, 1/4" LG BEARING	8
14	5-130	DOOR LATCH	2
15	5-402LA	WIPER BLADE	2
16	5-122	8" SS HINGE	2
17	5-123B 290-1235	WIPER LIFTING BRACKET	2
18	21-1127	ROLLER	8
19	21-1050	PARALLEL LINK	4
20	H-70055	HCS 5/16" - 18 X 1" SS	16
21	H-250HCN	HCS 1/4"-20	8
22	H-71013	FW 1/4" X 5/8" SS	36
23	H-71021	FW 3/8" X 7/8" SS	6
24	H-70861	NYLOK 5/16" - 18 SS	8
25	H-71065	LW 5/16" SS	8
26	H-70003	HCS 1/4"- 20 X 3/4" SS	36
27	H-37038	JNYL 5/8"- 11	2
28	H-70712	HN 3/8"-16 SS	6
29	H-70103	HCS 3/8"-16 X 3/4" SS	6
30	290-1234	.375 OD. X .31 ID. X .625 LG	4
31	H-70005	HCS 1/4"- 20 X 1" SS	8
32	H-71067	LW 3/8" SS	6
33	H-70710	HN 1/4"- 20 SS	36
34	H-13337	HB 5/8"- 11 X 13"	2
35	H-71063	LW 1/4" SS	36
36	H-72706	FHP 1/4"- 20 X 5/8" SS	18
37	H-78015	FW 5/16" X 3/4" SS	13
38	290-1245	3/8" ID, 1/2" OD, 3/8" LG, FLANGE BEARING	8

STEERING/TRACTION ASSEMBLY

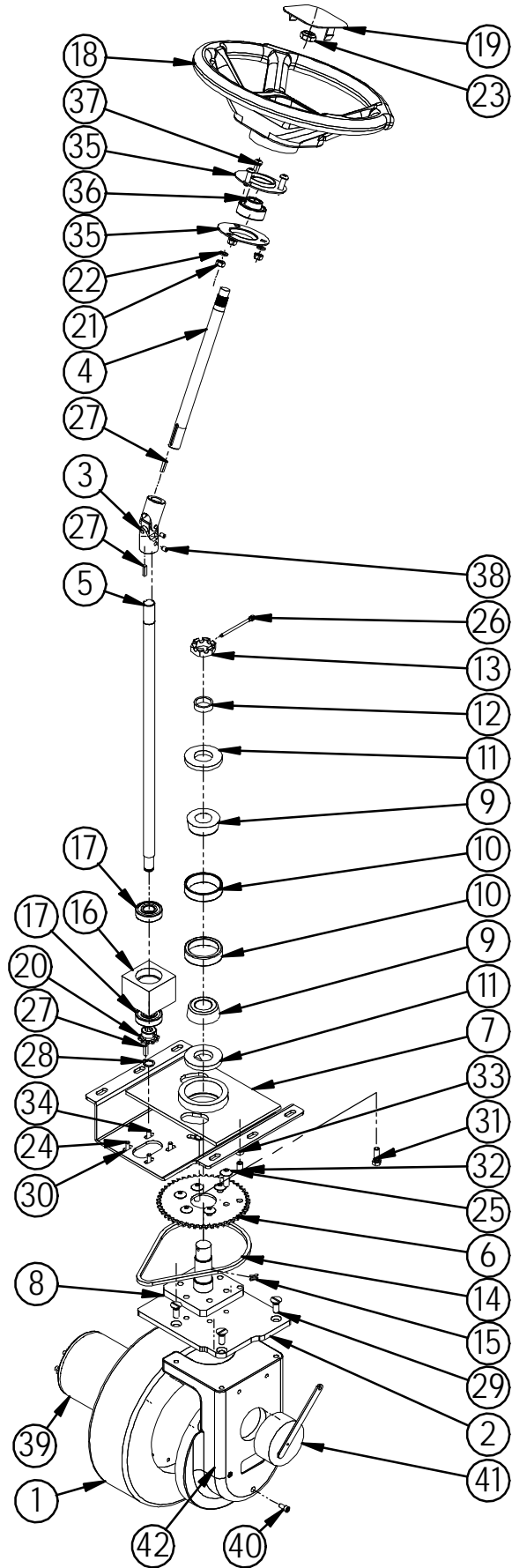

STEERING/TRACTION ASSEMBLY

Item	Part No.	Part Description	Qty
1	290-7315 290-7320	BLACK TIRE (OPTIONAL) GREY TIRE (STANDARD)	1
2	290-7326	PIVOT PLATE	1
3	290-7110	U-JOINT	1
4	290-7090	STEERING SHAFT, UPPER	1
5	290-7120	STEERING SHAFT, LOWER	1
6	37-7314	LARGE STEERING SPROCKET	1
7	37-7315	DROP PLATE	1
8	37-7316	PIVOT SHAFT	1
9	37-7317	TAPERED ROLLER BEARING	2
10	37-7318	BEARING CAP	2
11	37-7319	STEERING SHAFT SEAL	2
12	37-7320	PRE LOAD SLEEVE	1
13	37-7321	SLOTTED NUT, 2.0 - 12	1
14	290-7327	STEERING CHAIN	1
15	5-831	MASTER LINK	1
16	8-723	BEARING BLOCK	1
17	8-723B	BEARING	2
18	8-703	STEERING WHEEL	1
19	8-701A	STEERING COVER	1
20	5-826	10 TOOTH SPROCKET	1
21	H-36104	HN 5/16"-18	6
22	H-33620	LW 5/16"	5
23	H-37038	JNYL 5/8"- 11	1
24	H-13003	HCS 1/4"-20 X 3/4"	2
25	H-24103	BHSCS 3/8"- 24 X 1"	6
26	H-65129	3/16" X 2-1/2" COTTER PIN	1
27	H-00270	3/16" X 3/4" KEY	3
28	H-68013	SNAPRING 5/8"	1
29	H-28121	FHS 3/8-16 X 1"	4
30	H-33618	LW 1/4"	2
31	H-13055	HCS 5/16"-18 X 1"	2
32	H-25595	SS CP 3/8"- 24 X 1/2"	1
33	H-05233	PVC TUBING	1
34	H-24617	SHCS, LOW HEAD, 1/4- 20 X 5/8"	2
35	4-364A	FLANGE, 1.75" ID	2
36	4-352	BEARING	1
37	H-94071	BHSCS 5/16-18 X 1	3
38	H-25328	SSS CP 1/4"-20 X 3/8"	2
39	290-7313	24V, 2HP, MOTOR	1
40	H-79041	SHCS 1/4-20 X 1/2 SS	3
41	290-7323	24 VOLT ELECTRIC BRAKE	1
42	5-2225	END HOUSING	1

ACTUATOR SLIDE ASSEMBLY

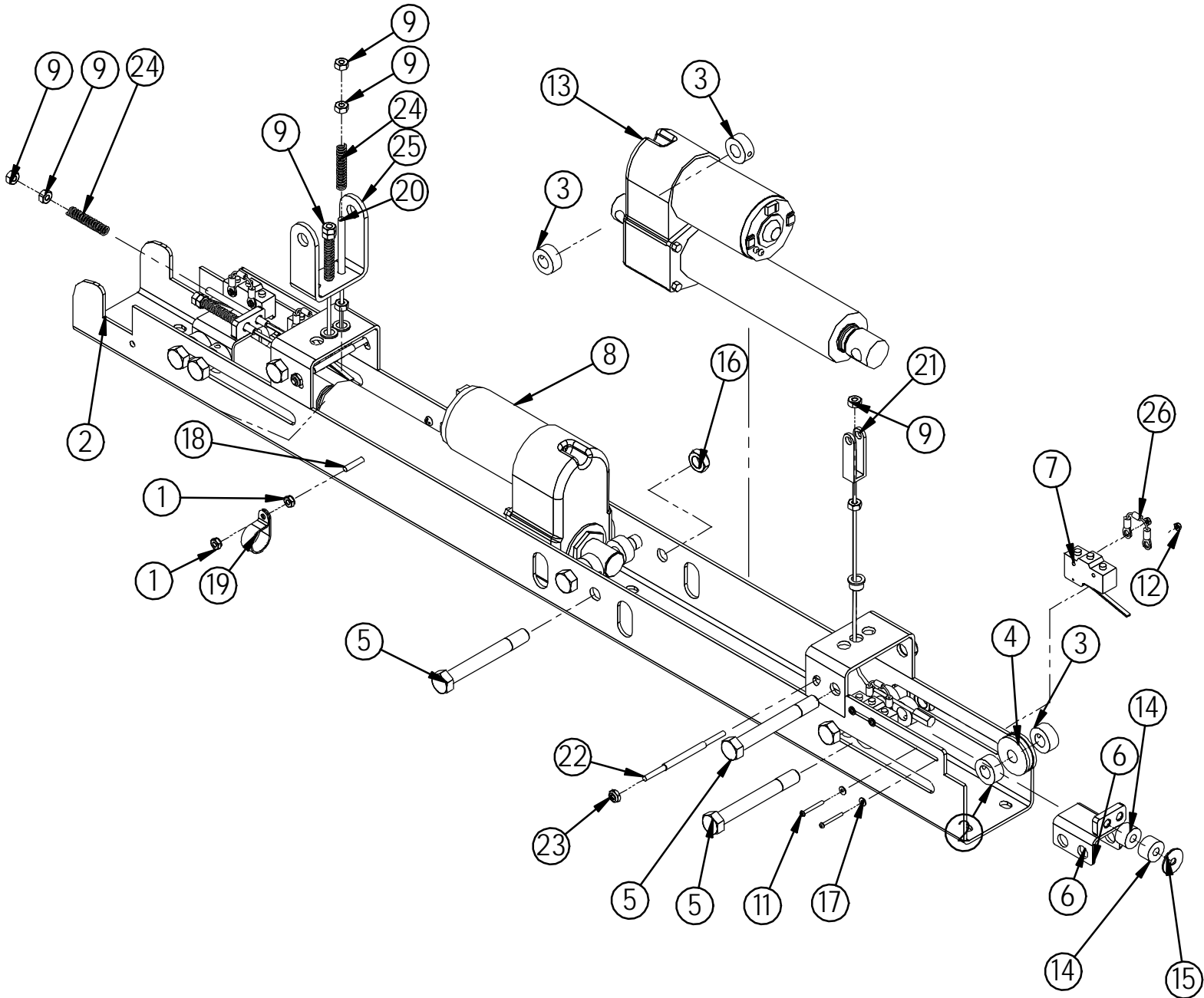

ACTUATOR SLIDE ASSEMBLY

Item	Part No.	Part Description	Qty
1	H-37408	KN #10-32	4
2	290-7660	ACTUATOR CHANNEL	1
3	H-33374	SHAFT COLLAR, 1/2" ID	16
4	5-772	PULLEY, NYLON	3
5	H-11219	HCS 1/2"- 13 X 4.0"	8
6	290-7710	CABLE TROLLEY	2
7	5-223	LIMIT SWITCH	4
8	290-2210	ACTUATOR; 1000 LB. LOAD (20:1)	1
9	H-36152	HN 1/4"- 28	18
10	H-6389	FLANGED BUSHING 3/8" ID X 5/8" OD, NYLON	3
11	H-28679	PPH #4-40 X 1"	8
12	H-37006	NYLOK #4-40	6
13	5-221	ACTUATOR; 1000 LB. LOAD (10:1)	1
14	21-7690	POLYURETHANE SPRING	2
15	H-33207	FW 1/4" X 1"	1
16	H-37032	JAM NYLOK NUT, 1/2"- 13	8
17	H-33066	FW #4 SAE	8
18	H-72566	RPH #10-32 X 1" SS	2
19	H-78LC	7/8" NYLON LOOP CLAMP	2
20	290-7713	SCRUBHEAD LIFT CABLE 12.25"	2
21	290-7890	SQUEEGEE LIFT CABLE	1
22	H-01321	DOUBLE ENDED STUD, 1/4-20 X 4" SS	2
23	H-NJ04C	JNYL 1/4" - 20 SS	4
24	290-7712	COMPRESSION SPRING	6
25	290-4010	LIFT BRACKET	1
26	5-270	EMF SUPP DIODE	4
27	H-01320	FW 1/2" ID X 1/8" THICK NYLON	2

DISK SCRUBHEAD ASSEMBLY

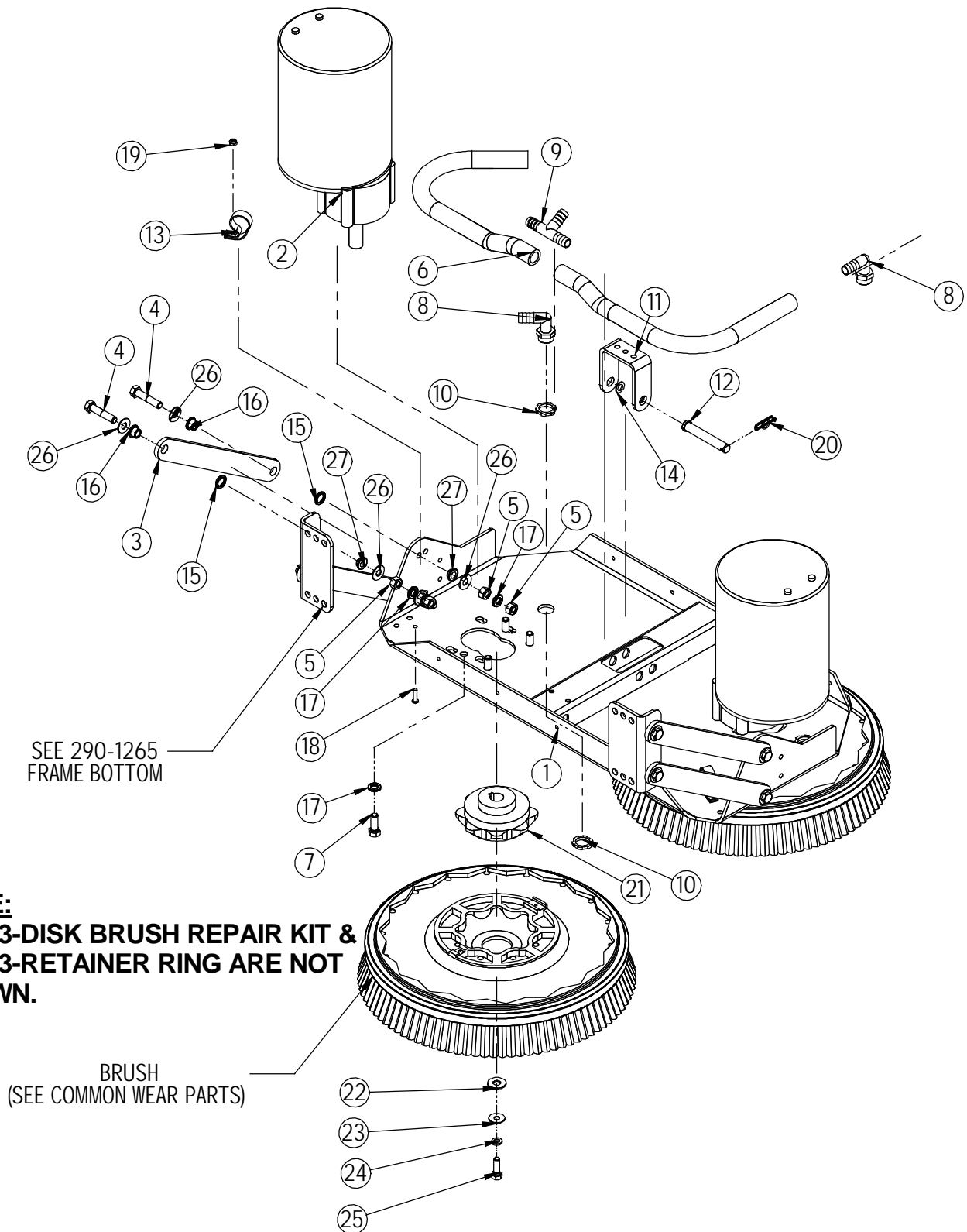

DISK SCRUBHEAD ASSEMBLY

Item	Part No.	Part Description	Qty
1	7-402	SCRUB HEAD PLATFORM	1
2	38-222	MOTOR 1 HP X 350 RPM	2
3	5-124	LATERAL ARM	4
4	H-70110	HCS 3/8"- 16 X 1-3/4" SS	8
5	H-70712	HN 3/8"-16 SS	11
6	7-4034	REINF. HOSE 5/8 ID X 18" LG	1
7	H-70105	HCS 3/8"- 16 X 1" SS	7
8	5-447	1/2 NPT X 1/2" BARB ELBOW	2
9	5-446	1/2 " PLASTIC BARB TEE	1
10	H-07005	1/2" NPT LOCKNUT	4
11	290-4010	LIFT BRACKET	1
12	H-CP238	1/2" X 3" CLEVIS PIN	1
13	H-78LC	7/8 LOOP CLAMP	2
14	H-76063	FW 3/8" NYLON	2
15	290-1247	FW BRONZE .50" ID X 1.0" OD X .062	5
16	290-1245	3/8" ID, 1/2" OD, 3/8" LG, FLANGE BEARING	3
17	H-71067	LW 3/8" SS	11
18	H-72565	RPH #10-32 X 3/4" SS	1
19	H-70858	NYLOK #10-32 SS	1
20	H-RUE22	1/2" RUE RING COTTER	1
21	21-5000	BRUSH DRIVER	2
22	H-99001	FW 3/8" SS	2
23	H-71016	FW 5/16" X 7/8" USS	2
24	H-71065	LW 5/16" SS	2
25	H-70055	HCS 5/16"- 18 X 1" SS	2
26	H-71017	FW 3/8" SS	10
27	290-1243	3/8" ID, 1/2" OD, 1/4" LG BEARING	2

CYLINDRICAL-DECK

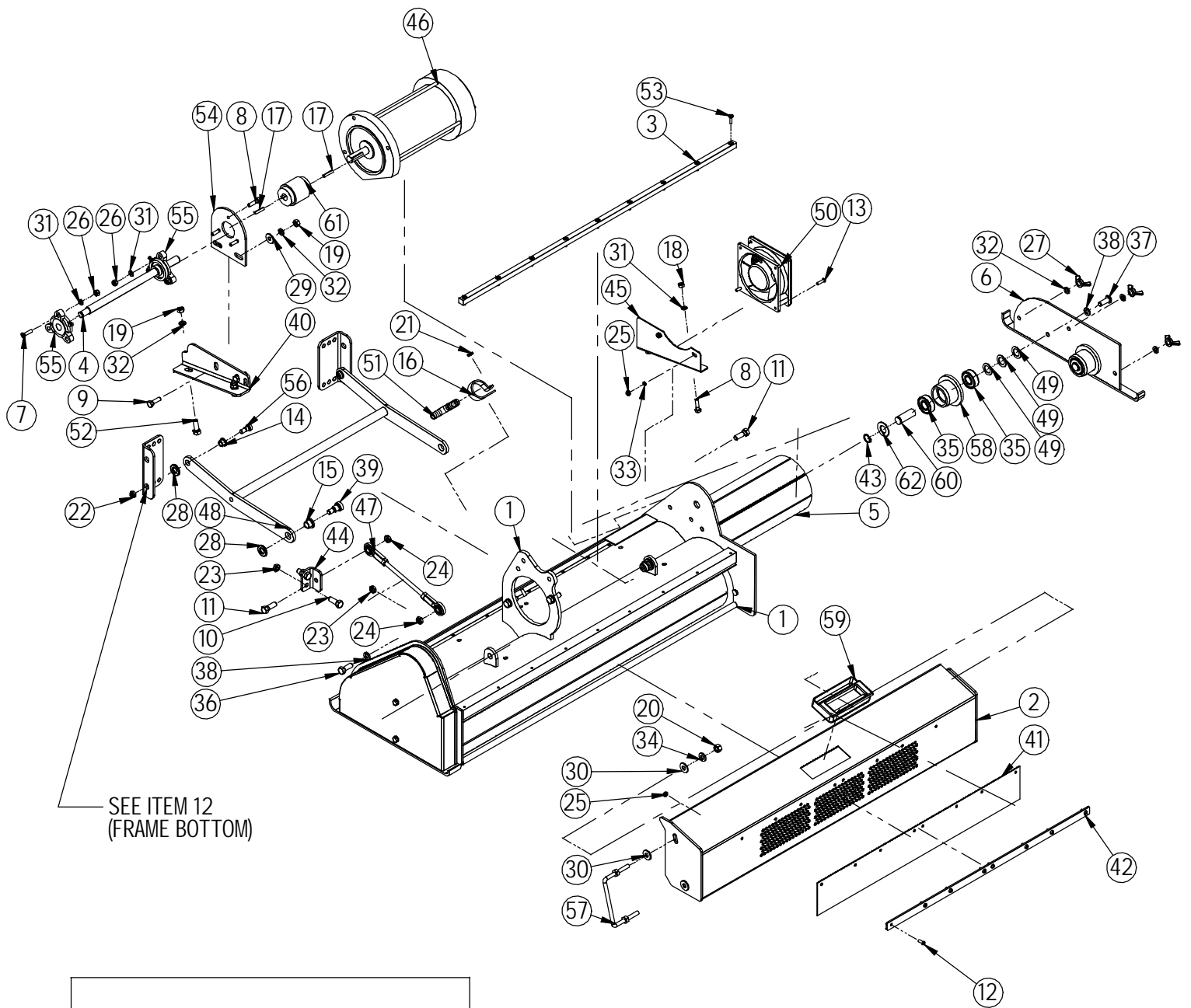

SEE ITEM 12
(FRAME BOTTOM)

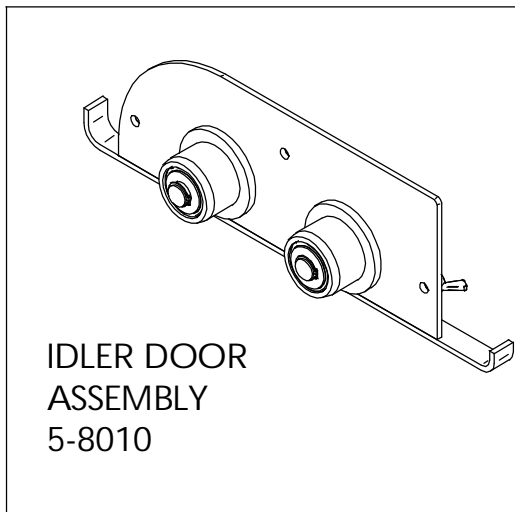

IDLER DOOR
ASSEMBLY
5-8010

CYLINDRICAL-DECK

Item	Part No.	Part Description	Qty
1	32-9000	32" CYL BRUSH HEAD	1
2	25-9050 28-9050 7-811	25" HOPPER 28" HOPPER 32" HOPPER	1
3	25-8320 28-8320 5-832	HOPPER RAIL, 25" HOPPER RAIL, 28" HOPPER RAIL, 32"	1
4	290-8355 290-8360 290-8365	DRIVE SHAFT, 25" CYL DRIVE SHAFT, 28" CYL DRIVE SHAFT, 32" CLY	1
5	SEE PAGE 4	CYLINDRICAL BRUSH	2
6	5-801	IDLER DOOR	1
7	H-72710	FHP 1/4"- 20 X 1" SS	3
8	H-70005	HCS 1/4"- 20 X 1" SS	5
9	H-70055	HCS 5/16"- 18 X 1" SS	2
10	H-70105	HCS 3/8"- 16 X 1" SS	2
11	H-01219	HCS 3/8"- 24 X 1 1/8" SS	2
12	H-72563	RPH #10-32 X 1/2" SS	8
13	H-72565	RPH #10-32 X 3/4" SS	2
14	290-1245	3/8" ID, 1/2" OD, 3/8" LG, FLANGE BEARING	2
15	290-1246	1/2" ID X 5/8" OD X 1/2" LG FLANGED BEARING	2
16	H-3225T5	RUBBER LOOP CLAMP	1
17	H-01125	3/16" X 1" KEY	2
18	H-70710	HN 1/4"- 20 SS	2
19	H-70711	HN 5/16"- 18 SS	4
20	H-36106	HN 3/8"-16	2
21	H-NJ04C	JNYL 1/4" - 20 SS	1
22	H-NJ05C	JNYL 5/16"- 18 SS	2
23	H-0129158	JNYL 3/8- 16 SS	4
24	H-00531	JNYL 3/8- 24 SS	2
25	H-70858	NYLOK #10-32 SS	10
26	H-70860	NYLOK 1/4"- 20 SS	6
27	H-70911	WINGNUT 5/16"- 18 SS	3
28	290-1248	FW BRONZE .500 ID X 1.00 OD X .125 THK	4

Item	Part No.	Part Description	Qty
29	H-71016	FW 5/16" X 7/8" USS	2
30	H-33008	FW 3/8" USS	4
31	H-71063	LW 1/4" SS	8
32	H-71065	LW 5/16" SS	7
33	H-33614	LW #10	2
34	H-33622	LW 3/8"	2
35	1-421	IDLER BEARING	4
36	H-70105	HCS 3/8-16 X 1" SS	3
37	H-73815	BH SCHS 3/8-16 X 1" SS	1
38	H-71067	LOCKWASHER 3/8 SS	4
39	H-25452	SB 1/2" X 1/2" SS	2
40	28-9005	FAN PLATE MOUNT	1
41	28-9060	HOPPER SPLASH SHIELD	1
42	28-9070	SPLASH SHIELD HOPPER STRIP	1
43	H-35313	17mm SNAP RING	2
44	290-1350	CYL SUPPORT BRACKET	1
45	290-8100	FAN MTG BRACKET	1
46	22-2110	2 HP MOTOR	1
47	7-843	ADJ LATERAL ARM	1
48	290-9020	CYLINDRICAL LIFT ARM	1
49	H-17002	FW 17mm NYLON	6
50	5-212	COOLING FAN	1
51	5-446	1/2 " PLASTIC BARB TEE	1
52	H-70055	HB 5/16"- 18 X 1" SS	2
53	H-72684	FHP 10-32 X 3/4" SS	9
54	5-8102	BEARING PLATE	1
55	5-829	FLANGE BEARING	2
56	H-25444	SB 3/8" X 3/8" SS	2
57	5-834	HOPPER HANDLE	1
58	5-838	BRUSH IDLER	2
59	5-849	RECESSED HANDLE	1
60	5-858	IDLER SHAFT	2
61	8-613	FLEXIBLE COUPLER	1
62	H-00797	FW 17.3mm X 33.2mm X 1.6mm	2

CYLINDRICAL-MECHANICAL

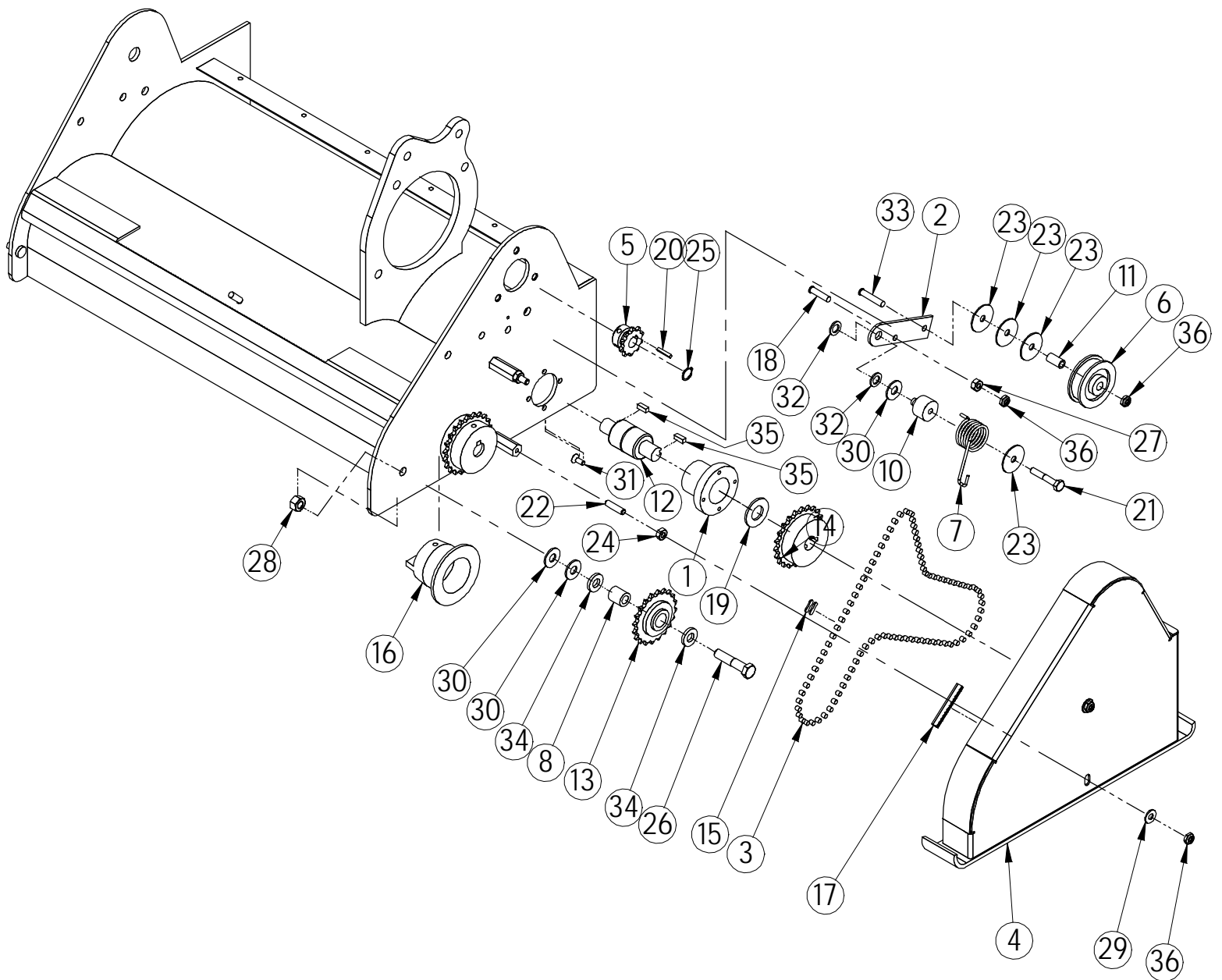

CYLINDRICAL-MECHANICAL

Item	Part #	Description	Qty
1	1-305	BEARING HOUSING	2
2	22-7970	MOVABLE IDLER ARM	1
3	22-8300	DRIVE CHAIN	1
4	22-9021	CHAIN GUARD	1
5	290-8260	10 TOOTH SPROCKET	1
6	4-317	IDLER PULLEY	1
7	4-319	TENSION SPRING	1
8	5-793	IDLER SPACER	1
9	5-796	GREASE (USE ONLY OEM GREASE - NOT SHOWN)	1
10	5-798	SPRING PIVOT	1
11	5-822	Spacer, 1/4" ID, 3/8" OD, 11/16" Long	1
12	5-824	DRIVE BEARING	2
13	5-827	20 TOOTH SPROCKET	1
14	5-828	22 TOOTH SPROCKET	2
15	5-831	MASTER LINK	1
16	5-837	BROOM DRIVER	2
17	5-845A	WINDLACING - (WEATHER STRIPPING)	1
18	H-00272	SCS 1/4"- 20 X 1.0"	1
19	H-00279	WASHER 5/8 TEFLON	1
20	H-01343	1/8" X 1/8" X 3/4" KEY	1
21	H-15009	HCS 1/4"- 20 X 1-1/2" GRADE 8	1
22	H-255HD	STUD 1/4"- 20 X 1"	2
23	H-33208	F W 1/4" X 1 1/4"	4
24	H-36202	JN 1/4"- 20	2
25	H-68011	SNAPRING .5"	1
26	H-70145	HCS 3/8-24 X 1 3/4" SS	1
27	H-70710	HN 1/4"- 20 SS	1
28	H-70732	HN 3/8"- 24 SS	1
29	H-71013	FW 1/4" X 5/8" SS	2
30	H-71017	FW 3/8" SS	3
31	H-72682	FHP 10-32 X 1/2" SS	1
32	H-76063	FW 3/8" NYLON	2
33	H-93580	SCS 1/4"- 20 X 1 1/4"	1
34	H-98025	WASHER 3/8 GRADE 8	2
35	H-K1432	3/16" X 1/2" KEY	4
36	H-NJ04C	JNYL 1/4" - 20 SS	4

SQUEEGEE ASSEMBLY

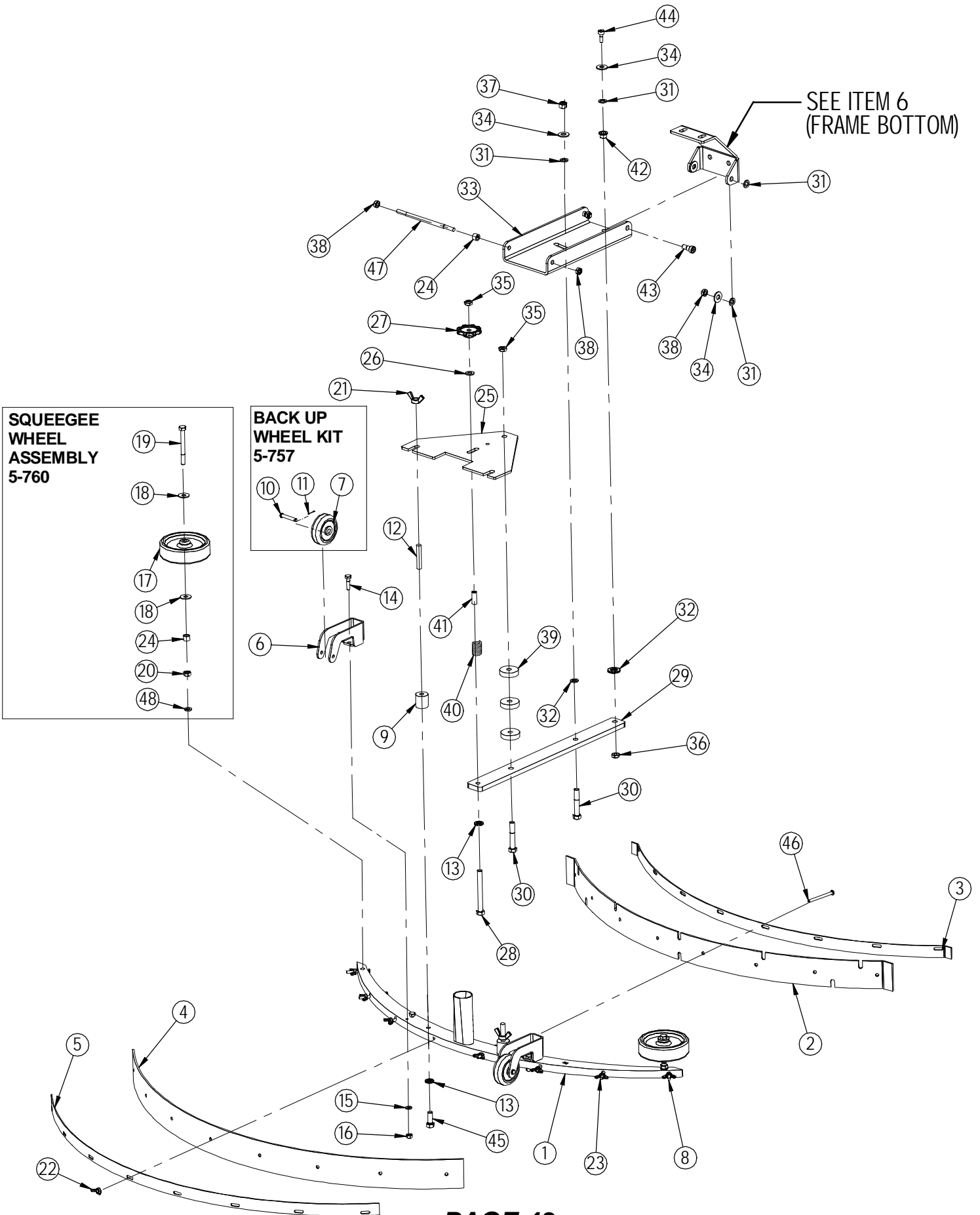

SQUEEGEE ASSEMBLY

Item	Part No.	Part Description	Qty	Item	Part No.	Part Description	Qty
1	22-7181	30" SQUEEGEE WELDMENT	1	20	H-70711	HN 5/16" - 18 SS	2
	25-7181	35" SQUEEGEE WELDMENT		21	5-786	WINGNUT 3/8"-16 NICKEL	2
	28-7181	38" SQUEEGEE WELDMENT		22	H-70908	WINGNUT 10-32 SS	8
	290-7181	45" SQUEEGEE WELDMENT		23	H-00249	PPH #10-32 X 2 1/4" SS	4
2	22-755G	30" SQUEEGEE BLADE, FRONT	1	24	H-33371	5/16" ID SHAFT COLLAR	3
	25-755G	35" SQUEEGEE BLADE, FRONT		25	21-7610	SQUEEGEE TRIANGLE PLATE	1
	28-755G	38" SQUEEGEE BLADE, FRONT		26	H-33080	FW 5/16" SAE	1
	290-756G	45" SQUEEGEE BLADE, FRONT		27	21-7205	PALM GRIP KNOB, 3/8-24	1
3	22-7170	30" SQUEEGEE BAND, FRONT	1	28	H-10055	HCS 3/8" - 24 X 3.5" SS	1
	25-7170	35" SQUEEGEE BAND, FRONT		29	290-7150	SQUEEGEE TRAIL ARM	1
	28-7170	38" SQUEEGEE BAND, FRONT		30	H-70136	HCS 3/8" - 24 X 2 1/4" SS	2
	290-7170	45" SQUEEGEE BAND, FRONT		31	H-76063	FW 3/8" NYLON	7
4	22-754G	30" SQUEEGEE BLADE, REAR	1	32	290-1248	FW BRONZE .500 ID X 1.00 OD X .125 THK	1
	25-754G	35" SQUEEGEE BAND, REAR		33	290-7130	SQUEEGEE SWING PLATE	1
	28-754G	38" SQUEEGEE BLADE, REAR		34	H-71017	FW 3/8" SS	4
	7-753G	45" SQUEEGEE BLADE, REAR		35	H-00531	JNYL 3/8- 24 SS	2
5	22-7160	30" SQUEEGEE BAND, REAR	1	36	H-0129158	JNYL 3/8- 16 SS	1
	25-7160	35" SQUEEGEE BAND, REAR		37	H-77862	NYLOK 3/8" - 16 SS	1
	28-7160	38" SQUEEGEE BAND, REAR		38	H-NJ05C	JNYL 5/16" - 18 SS	4
	290-7160	45" SQUEEGEE BAND, REAR		39	4-446	GROMMET-3/8 ID X 1-1/2 OD X .375	3
6	21-7220	SQUEEGEE TRAIL MOUNTS	2	40	21-7240	SPRING	1
7	21-7570	BACK UP WHEEL (GREY)	2	41	7-782C	5/16 CLEAR TUBING	1
8	H-72555	PPH #10-32 X 1 3/4" SS	2	42	290-1245	3/8" ID, 1/2" OD, 3/8" LG, FLANGE BEARING	1
9	5-846	PIVOT SHAFT	2	43	H-2S444	SB 5/16" X 3/8" SS	2
10	HZCP44	CLEVIS PIN 1/4 X 1 1/2"	2	44	H-79054	SHCS 5/16-18 X 3/4 SS	1
11	H-RUE8	1/4" RUE RING COTTER	2	45	H-70105	HCS 3/8" - 16 X 1" SS	2
12	H-S1060	STUD 3/8-16 X 1 1/2" SS	2	46	H-00288	PPH #10-32 X 2 1/2" SS	2
13	H-71067	LW 3/8" SS	3	47	H-90281	1/4-20 X 6" DOUBLE ENDED STUD	1
14	H-70005	HCS 1/4" - 20 X 1" SS	4	48	H-71065	LW 5/16" SS	2
15	H-71063	LW 1/4" SS	4				
16	H-70710	HN 1/4" - 20 SS	4				
17	5-760B	SIDE WHEEL (GREY)	2				
18	H-71016	FW 5/16" X 7/8" USS	4				
19	H-70065	HCS 5/16" - 18 X 3" SS	2				

CENTRAL COMMAND II

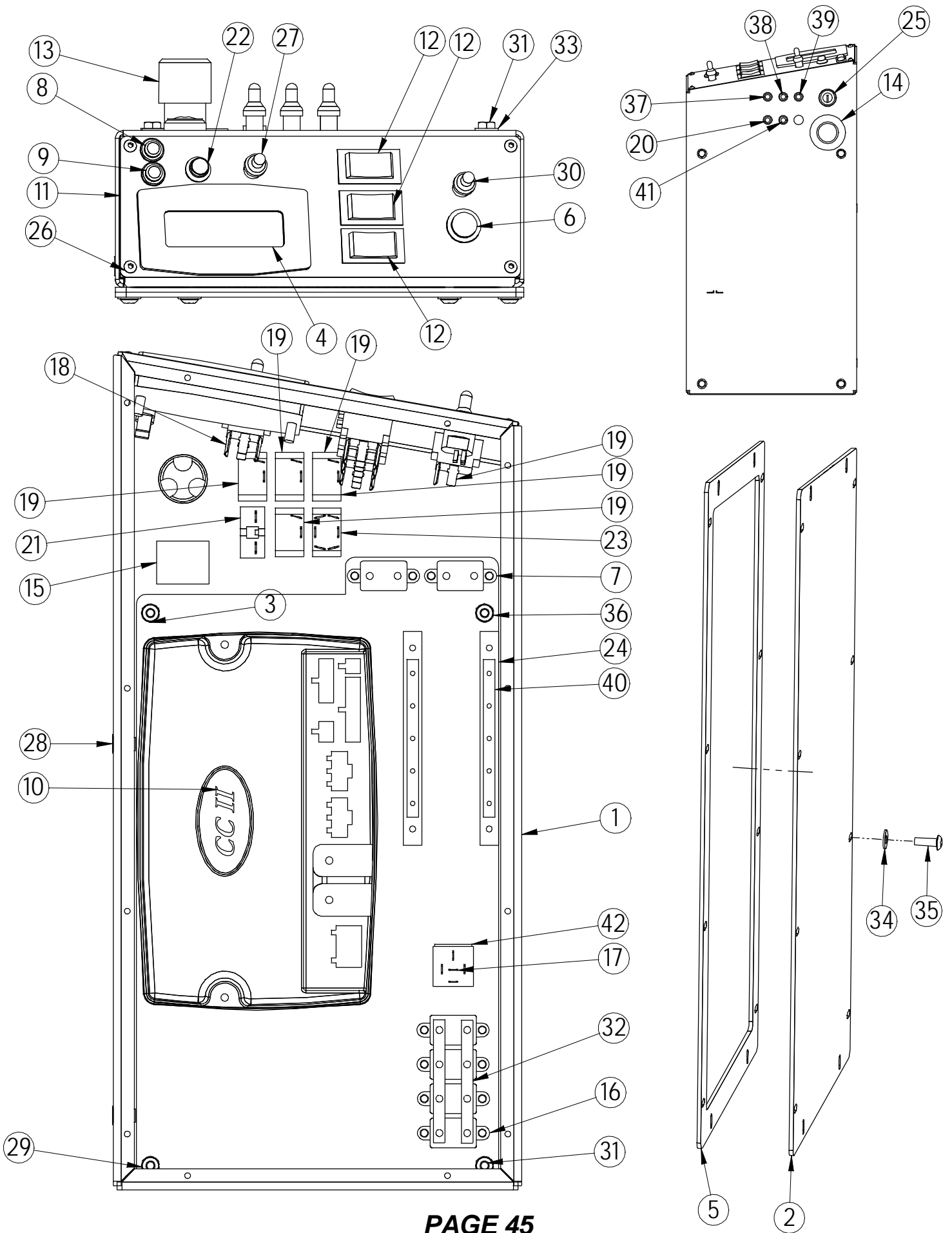

CENTRAL COMMAND II

Item	Part No.	Part Description	Qty
1	290-2010	CONTROL PANEL	1
2	290-2001	ACCESS COVER	1
3	290-2006	HARDWARE PANEL	1
4	290-2891	LCD SCREEN	1
5	290-2004	ACCESS COVER GASKET	1
6	290-2015	ONE TOUCH BUTTON	1
7	290-2815	CIR. BREAKER - 15A, 24V	2
8	290-2300	LOW SOLUTION (AMBER)	1
9	290-2310	FULL RECOVERY (RED)	1
10	290-2890	COMPUTER CONTROL	1
11	290-2013	CONT PANEL TOP PLATE	1
12	5-234	SWITCH, ROCKER, DPDT, ON/ON	3
13	5-300	EMERGENCY SHUT OFF (OPT)	1
14	5-301	EMERG LEGEND PLATE (OPT)	1
15	5-302	EMERG CONTACT BLK (OPT)	1
16	5-289	CIR BREAKER 24V 50A	4
17	5-293	15 AMP RELAY	1
18	7-283	SWITCH, TOGGLE, MOM/OFF/MOM (DPDT)	1
19	5-892	TOGGLE, ON-OFF SPST	5
20	5-892A	PROTECTIVE BOOT, TOGGLE SWITCH, (GRAY)	1
21	7-837	FUSE RESETTABLE 2 AMP	1
22	7-229	PUSH BUTTON SWITCH	1
23	7-821	SWITCH, TOGGLE, ON/ON (DPDT)	1
24	7-287	BUSS BAR UHMW	2
25	4-234	KEY SWITCH	1
26	H-73743	BHSCS 10-32 X 1/2" SS	4
27	H-01200	PROTECTIVE BOOT, TOGGLE SWITCH, (BLACK)	1
28	H-250HCN	HCN 1/4" -20	2
29	H-36102	HN 1/4" -20	12
30	H-01196	PROTECTIVE BOOT, TOGGLE SWITCH, (RED)	1
31	H-13005	HCS 1/4" -20 X 1"	4
32	E-4HBB	4 HOLE BUSS BAR	2
33	H-33078	FW 1/4" SAE	4
34	H-71013	FW 1/4" X 5/8" SS	12
35	H-73754	BHSCS 1/4 - 20 X 3/4 SS	12
36	H-33618	LW 1/4"	4
37	H-01199	PROTECTIVE BOOT, TOGGLE SWITCH, (BLUE)	1
38	H-01195	PROTECTIVE BOOT, TOGGLE SWITCH, (WHITE)	1
39	H-01198	PROTECTIVE BOOT, TOGGLE SWITCH, (GREEN)	1
40	E-5HBB	5 HOLE BUSS BAR	2
41	H-01197	PROTECTIVE BOOT, TOGGLE SWITCH, (YELLOW)	1
42	290-2020	BRACKET	1