



97

(Operator Manual)

MM282



This manual is furnished with each new TENNANT Model 97. It provides necessary operating and preventive maintenance instructions. Read this manual completely and understand the machine before operating or servicing it.

This manual covers all machine variations and standard accessories. The instruction portion of the manual consists of the Specification, Operation, Maintenance, and Appendix sections. The parts portion consists of the Low Dump Model Parts; Multi-Level Dump Model Parts; Accessories; Hydraulic Components; and Engine Parts sections.

All right side and left side references to the machine are determined by facing the direction of forward travel. All hardware considered to be of a common nature or locally available has been omitted from the parts sections. Be aware that this machine may contain metric hardware. Make sure you use equivalent hardware when replacement becomes necessary.

This machine will provide excellent service. However, the best results will be obtained at minimum costs if:

- The machine is operated with reasonable care.
- The machine is maintained regularly – per the maintenance instructions provided.
- The machine is maintained with Tennant Company supplied or equivalent parts.

Parts and supplies may be ordered by phone or mail from any Tennant Company parts and service center, distributor, or from any of the Tennant Company subsidiaries. Before ordering parts or supplies, be sure to have your machine model number and serial number handy. Fill out the data block below for future reference. The telephone numbers, telex numbers, mailing addresses, and locations of those outlets are listed in the Customer Documents section of the manual.

MACHINE DATA	
<i>Please fill out at time of installation.</i>	
Machine Serial Number –	_____
Engine Serial Number –	_____
Sales Representative –	_____
Customer Number –	_____
Date of Installation –	_____
Manual Number –	MM282
Revision:	00
Published:	2–91

Trademark Registered in: Austria, Benelux, Denmark, England, France, Germany, Italy, Spain, Switzerland, United States, Argentina, Australia, Canada, Japan, Mexico, Sweden, by Tennant Company, Minneapolis, Minnesota, U.S.A.

Acknowledgements: Technical information and/or illustrations supplied by Cessna Fluid Power Division; Kubota Ltd.; Eaton Corporation, Hydraulics Division.

Copyright 1991 Tennant Company, Printed in U.S.A.

ABOUT THIS MANUAL

The machine manual that you received with your TENNANT machine contains valuable information about the operation and maintenance, and numerous sections filled with TENNANT part numbers for the repair of the machine. Please read through this section titled *ABOUT THIS MANUAL* to become familiar with the contents of the machine manual, making the information you are looking for easier to find.

The machine manual consists of several sections of reference information, and the remainder contain part number information for ordering repair parts for the machine. Each section has a shaded bar at the top of the page with the name of that section. Just as this section has the title *ABOUT THIS MANUAL* on the top of each page. This way you can tell which section you are in at all times.

REFERENCE SECTIONS

The reference information sections of the manual are; General Information, Specifications, Operation, Maintenance, and Appendix.

GENERAL INFORMATION – The General Information section of the manual contains the safety precautions, the location of the safety labels on the machine, and a table of contents of the entire manual. The Safety Precautions are an overview of the safety measures to be observed when operating and maintaining your machine. The location of the safety labels show the mounting location of the safety labels for use in the replacement of the labels. The table of contents in this section is a list of all the table of contents that appear in the front of each section in the manual. This can be used for easy reference to locate information in a particular section of the manual.

SPECIFICATIONS – The Specifications section of the manual contains machine specification information useful in the operation and maintenance of the machine. This section gives you specification information on the engine, electric motors, brake system, hydraulics, fluid capacities, and machine weight to mention a few. The section also has a illustration of the top and side view of the machine with the height and width dimensions displayed.

OPERATION – The Operation section of the manual contains information needed to operate the machine. This section will list the controls and instruments on the machine, overview the machine operation, and tell you how to transport and store the machine.

MAINTENANCE – The Maintenance section contains information on the suggested maintenance procedures and adjustments to keep your machine in top operating condition. The section includes a Maintenance Chart listing the maintenance schedule and the areas of the machine to be addressed. Each subject of maintenance is covered in more detail in such areas as Lubrication, Hydraulics, Engine, and Electrical System.

APPENDIX – The Appendix contains hardware and hydraulic information. Standard hardware torques and identification information is included, plus hydraulic torques if your machine is hydraulically controlled.

PART SECTIONS

The remaining sections of the manual contain part number information for ordering repair parts for your machine. The manual contains part number information on every type of machine model available in the model size of your particular machine. Therefore there will be part number information in your manual you will not need to refer to when wanting to place an order.

The main thing you need to know about your machine is what type of model is it. Is the machine powered by an engine or batteries? If the machine has an engine, is it fueled from gasoline, LPG, or gasoline? If it is a mid-sized or larger sweeper, is it multi-level or low dump? For the scrubbers, is it SRS® or standard. Determining this information about your machine will help guide you through the separate parts sections to find the repair part you need.

ABOUT THIS MANUAL

The smaller line of sweeper and scrubbers have less complicated part section arrangement, and are easier to find your way through the parts sections. The larger machines can have quite a variety of model types which significantly increases the size to the machine manual. Because of this, on the larger machine we made the first part section, Section 5, a part section which contains parts common to all type of the machine. If the machine has an engine, this section contains parts information on a gasoline powered machine.

The remaining sections contain only parts information which is unique to that particular machine type, such as unique diesel parts on the machine, or unique SRS® parts. Knowing the machine model type you have is important when searching for that part information you need for ordering repair parts. Start in that unique section first when looking for a part, then go to the first parts section, Section 5, if the part can't be found in the unique section.

MACHINE SERIAL NUMBERS

When a design change takes place to a machine, the changes are indicated in the parts sections with machine serial numbers. Know the serial number of your machine which can be found on the machine data plate mounted on the machine. Record this number on the inside front cover of your manual along with your customer number.

Machine number usage is recorded in the *Machine Serial Number* column of the parts lists in the parts sections of the manual. If the machine serial number column lists zeros on the left side of the dash, then this part is used on all machines; such as (000000–).

If the column lists zeros on the left of the dash and a number on the right of the dash, then the part is used on machines up to and including that machine serial number; such as (00000–002345).

For parts that are used on machines beginning at and continuing on from a certain serial number, the column would list a serial number on the left of the dash and have blank spaces on the right side of the dash; such as (002346–). This part would be used on machines starting with that machine serial number and greater.

Finally, parts can be used on machines with serial numbers in a certain block of numbers. In this situation there is a serial number on the left and right side of the dash. The part is then used on a machine with a serial number starting at the number on the left and up to and including the number on the right; such as (002346–008900).

PARTS ASSEMBLIES

A part assembly has parts within the assembly, such as a parking brake consisting of other smaller parts. What parts are contained in a part assembly can be determined by an indentation arrangement in the description column of the parts lists.

Here is an example of a part assembly, in this case we will use the parking brake mentioned previously:

Machine			
Serial Number	Description		Qty.
(000000–)	Parking Brake		1
(000000–)	Pin, Roll		1
(000000–)	Link		1
(000000–)	Spring, Compression		1
(000000–)	Pin, Roll		1
(000000–)	Support		1
(000000–)	Lever, Release		1
(000000–)	Rod, Parking Brake		1
(000000–)	Washer, 0.50"		3

In this example, the parts whose descriptions are indented under the parking brake are all parts of the parking brake. When you order the parking brake you will receive all the parts listed under it. You also can order any of the individual parts listed under the parking brake if it is the only part you need.

SUPPLIER COMPONENT BREAKDOWNS

TENNANT purchases certain components of the machine from suppliers. Some of these components are engines, hydraulic pumps and motors, electric motors, and solution pumps.

For those purchased components that are repairable, lists of parts for them appear in the later part of the parts sections. These are the supplier breakdowns. The engine breakdown contains both supplier and TENNANT parts numbers for repair parts. Breakdowns for hydraulic and electrical components have TENNANT part numbers for the parts TENNANT supplies. The serial numbers listed in any of the parts lists in these sections is a serial number the manufacturer uses to identify design changes in their particular component.

ORDERING REPAIR PARTS

Once you have located a part to order, there are several things you need to have to place the order. At the beginning of each parts section is an Ordering Repair Parts page which lists the information you will need to place your order. Review this list before placing the order.

SAFETY PRECAUTIONS

The following symbols are used throughout this manual as indicated in their descriptions:



WARNING: To warn of hazards or unsafe practices which could result in severe personal injury or death.

FOR SAFETY: To identify actions which must be followed for safe operation of equipment.

The following information signals potentially dangerous conditions to the operator or equipment. Read this manual carefully. Know when these conditions can exist. Locate all safety devices on the machine. Then, take necessary steps to train machine operating personnel. Report machine damage or faulty operation immediately. Do not use the machine if it is not in proper operating condition.

FOR SAFETY:

1. **Do Not Operate Machine:**
 - Unless Trained And Authorized.
 - Unless Operation Manual Is Read And Understood.
 - In Flammable Or Explosive Areas Unless Modified For Use In Those Areas.
 - In Areas With Possible Falling Objects Unless Equipped With Overhead Guard.
2. **Before Starting Machine:**
 - Check For Fuel Leaks.
 - Keep Sparks And Open Flame Away From Refueling Area.
 - Make Sure All Safety Devices Are In Place And Operate Properly.
 - Check Brakes And Steering For Proper Operation.
3. **When Starting Machine:**
 - Keep Foot On Brake And Directional Pedal In Neutral.
4. **When Using Machine:**
 - Use Brakes To Stop Machine.
 - Go Slow On Grades And Slippery Surfaces.
 - Use Care When Backing Machine.
 - Move Machine With Care When Hopper Is Raised.
 - Make Sure Adequate Clearance Is Available Before Raising Hopper.
 - Do Not Carry Riders On Machine.
 - Always Follow Safety And Traffic Rules.

5. **Before Leaving Or Servicing Machine:**
 - Stop On Level Surface.
 - Set Parking Brake.
 - Turn Off Machine And Remove Key.
6. **When Servicing Machine:**
 - Avoid Moving Parts. Do Not Wear Loose Jackets, Shirts, Or Sleeves When Working On Machine.
 - Block Machine Tires Before Jacking Machine Up.
 - Jack Machine Up At Designated Locations Only. Block Machine Up With Jack Stands.
 - Use Hoist Or Jack Of Adequate Capacity To Lift Machine.
 - Wear Eye And Ear Protection When Using Pressurized Air Or Water.
 - Avoid Contact With Battery Acid.
 - Avoid Contact With Hot Engine Coolant.
 - Keep Flames And Sparks Away From Fuel System Service Area. Keep Area Well Ventilated.
 - Use Cardboard To Locate Leaking Hydraulic Fluid Under Pressure.
 - Use TENNANT Supplied Or Equivalent Replacement Parts.
 - Disconnect Battery Connections Before Working On Machine.



WARNING: Engine Emits Toxic Gases. Severe Respiratory Damage Or Asphyxiation Can Result. Provide Adequate Ventilation. Consult With Your Regulatory Agency For Exposure Limits. Keep Engine Properly Tuned.



WARNING: Machine Can Emit Excessive Noise. Consult With Your Regulatory Agency For Exposure Limits. Hearing Loss Can Result. Wear Hearing Protection.



WARNING: Lift Arm Pinch Point. Stay Clear Of Hopper Lift Arms When Hopper Is Moving.



WARNING: Falling Hopper. Engage Hopper Support Bar Before Working Under Hopper.



WARNING: Moving Fan Blades. Keep Away.

GENERAL INFORMATION

The following safety labels are mounted on the machine in the locations indicated. If these, or any, labels become damaged or illegible, install a new label in its place.

ENGINE FAN LABEL – LOCATED ON THE TOP AND SIDE OF THE RADIATOR FAN SHROUD.



FALLING HOPPER LABEL – LOCATED ON RIGHT AND LEFT SIDE LIFT ARMS. LOW DUMP MODEL ONLY.

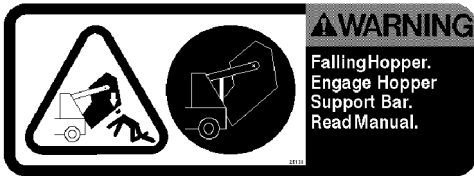

HOPPER LIFT ARM LABEL – LOCATED ON RIGHT AND LEFT SIDE LIFT ARMS.

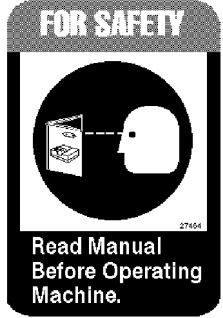

SAFETY LABEL – LOCATED ON THE DRIVER COMPARTMENT PANEL.

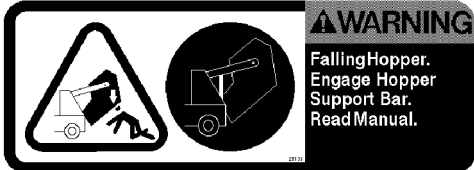

FALLING HOPPER LABEL – LOCATED ON UNDER-SIDE OF FRONT BUMPER. LOW DUMP MODEL ONLY.

06461

GENERAL INFORMATION

NOISE LABEL – LOCATED ON THE DRIVER COMPARTMENT PANEL.

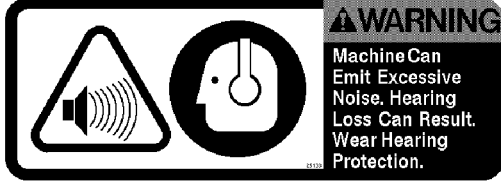

EMISSIONS LABEL – LOCATED ON THE DRIVER COMPARTMENT PA

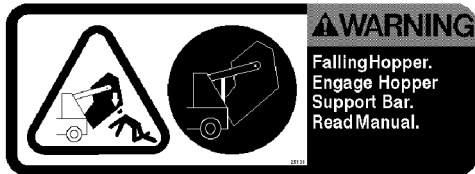
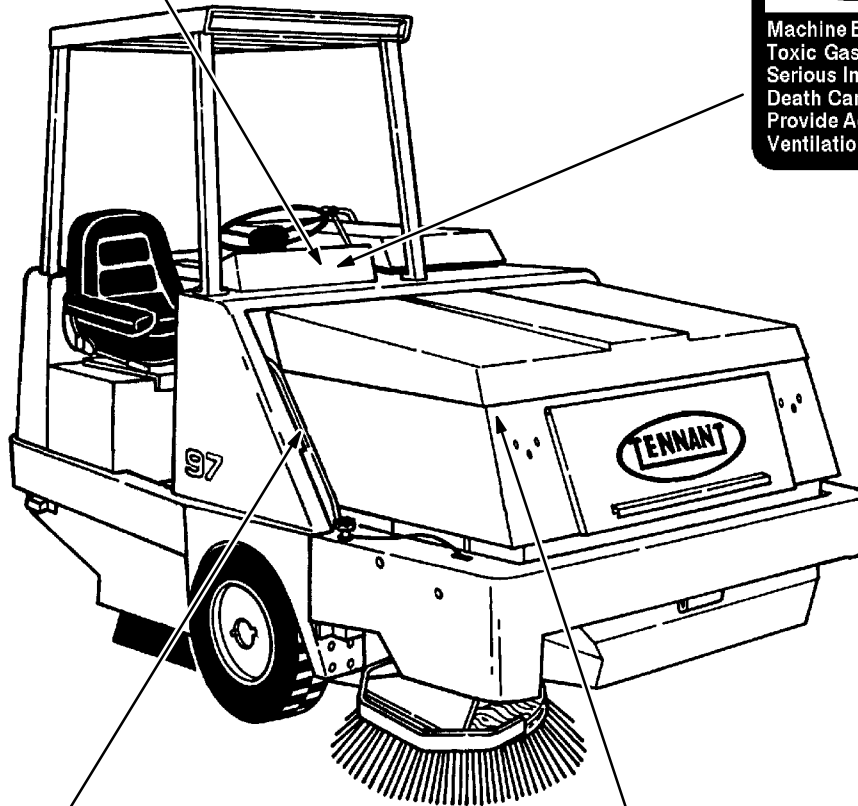

FALLING HOPPER LABEL – LOCATED ON LEFT SIDE LIFT ARM AND ON HOPPER SAFETY SUPPORT BAR, MULTI-LEVEL DUMP MODEL ONLY.

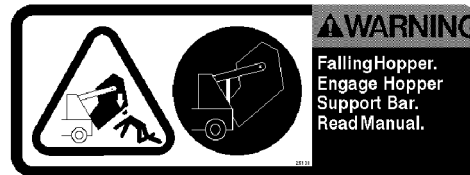

FALLING HOPPER LABEL – LOCATED ON LINTEL/PUMP BAFFLE, MULTI-LEVEL DUMP MODEL ONLY.

06461

CONTENTS

	Page		Page
GENERAL INFORMATION	i	STEERING WHEEL	2-10
SAFETY PRECAUTIONS	i	LOW ENGINE OIL PRESSURE LAMP ..	2-10
SPECIFICATIONS	1-1	ENGINE OIL PRESSURE GAUGE	2-10
MACHINE SPECIFICATIONS	1-3	VOLTAGE GAUGE	2-10
POWER TYPE	1-3	HOUR METER	2-11
POWER TRAIN	1-3	KEY-OPERATED IGNITION SWITCH ...	2-11
STEERING	1-3	PARKING BRAKE	2-11
HYDRAULIC SYSTEM	1-3	SIDE BRUSH HEIGHT ADJUSTMENT	
BRAKING SYSTEM	1-4	KNOB	2-11
SUSPENSION SYSTEM	1-4	HOPPER SUPPORT BAR	2-11
SYSTEM FLUID CAPACITIES	1-4	STABILIZER LEG	2-11
GENERAL MACHINE DIMENSIONS –		MACHINE OPERATION	2-12
CAPACITIES	1-5	NORMAL SWEEPING OPERATION ...	2-12
MACHINE WEIGHTS	1-5	PRE-START CHECKLIST	2-12
GENERAL MACHINE PERFORMANCE .	1-5	TO START MACHINE	2-12
MACHINE DIMENSIONS	1-6	TO SWEEP	2-12
OPERATION	2-1	TO DUMP LOW DUMP HOPPER ...	2-13
PREPARATION FOR OPERATION	2-3	TO DUMP MULTI-LEVEL DUMP	
AFTER UNCRATING AND BEFORE		HOPPER	2-14
OPERATING THE MACHINE:	2-3	POST OPERATION CHECKLIST –	
OPERATION OF CONTROLS	2-4	ENGINE OPERATING	2-14
MACHINE COMPONENTS	2-4	TO STOP MACHINE	2-15
INSTRUMENT PANEL SYMBOLS	2-4	POST OPERATION CHECKLIST –	
CONTROLS AND INSTRUMENTS	2-6	ENGINE STOPPED	2-15
BRAKE PEDAL	2-7	TO ENGAGE LOW DUMP MODEL	
DIRECTIONAL PEDAL	2-7	HOPPER SUPPORT BAR	2-15
MAIN BRUSH HEIGHT ADJUSTMENT		TO DISENGAGE LOW DUMP MODEL	
KNOB	2-7	HOPPER SUPPORT BAR	2-16
OPERATOR SEAT	2-8	TO ENGAGE MULTI-LEVEL DUMP	
THROTTLE LEVER	2-8	MODEL HOPPER SUPPORT BAR ...	2-16
MAIN BRUSH SWITCH	2-8	TO DISENGAGE MULTI-LEVEL DUMP	
SIDE BRUSH SWITCH	2-8	MODEL HOPPER SUPPORT BAR ...	2-17
FILTER SHAKER AND VACUUM		OPERATION ON GRADES	2-17
FAN SWITCH	2-8	OPTION OPERATION	2-18
HOPPER DOOR SWITCH	2-9	VACUUM WAND OPTION	2-18
HOPPER SWITCH	2-9	TO OPERATE VACUUM WAND	2-18
CIRCUIT BREAKERS	2-9	HOPPER DOLLY OPTION	2-19
MAIN BRUSH POSITION LEVER	2-9	TO REMOVE HOPPER WITH DOLLY	2-19
OPERATING LIGHTS SWITCH	2-9	TO REINSTALL HOPPER WITH DOLLY ..	2-20
HAZARD LIGHT SWITCH	2-10	HEATER/DEFROSTER OPTION	2-20
TURN SIGNAL SWITCH	2-10	SNOW BLADE OPTION	2-21
HOPPER DOOR LAMP	2-10	TO INSTALL SNOW BLADE	2-21
CLOGGED DUST FILTER LAMP	2-10	TO OPERATE SNOW BLADE	2-22
FUEL LEVEL GAUGE	2-10	TO REMOVE SNOW BLADE	2-23
HIGH ENGINE COOLANT		MACHINE TROUBLESHOOTING	2-24
TEMPERATURE LAMP	2-10	TRANSPORTING MACHINE	2-25
ENGINE COOLANT TEMPERATURE		PUSHING OR TOWING MACHINE	2-25
GAUGE	2-10	MACHINE JACKING INSTRUCTIONS ..	2-25
		MACHINE TIE-DOWN INSTRUCTIONS .	2-26
		MACHINE STORAGE	2-27
		STORING MACHINE	2-27

GENERAL INFORMATION

	Page		Page
MAINTENANCE	3-1	DIESEL FUEL TROUBLESHOOTING ...	3-26
RECOMMENDED FIRST 50-HOUR		CYLINDER HEAD	3-27
MACHINE INSPECTION	3-3	CYLINDER HEAD	3-27
MAINTENANCE CHART	3-4	VALVE CLEARANCE	3-27
LUBRICATION	3-6	ELECTRICAL SYSTEM	3-28
ENGINE	3-6	BATTERY	
REAR WHEEL SUPPORT PIVOT	3-6	3-28	
STEERING GEAR	3-6	ELECTRICAL SCHEMATIC	3-29
HOPPER COVER LATCH	3-6	BELTS AND CHAINS	3-32
SIDE BRUSH PIVOT PINS	3-7	ENGINE FAN BELT	3-32
STABILIZER LEG PIVOT PIN	3-7	STATIC DRAG CHAIN	3-32
FRONT WHEEL BEARINGS	3-7	DEBRIS HOPPER	3-33
HYDRAULICS	3-8	HOPPER DUST FILTERS	3-33
HYDRAULIC FLUID	3-8	TO REMOVE HOPPER DUST	
HYDRAULIC FLUID RESERVOIR	3-8	FILTER PANELS	3-33
TO DRAIN THE HYDRAULIC FLUID		TO INSTALL HOPPER DUST FILTERS	3-34
RESERVOIR	3-9	THERMO-SENTRY™	3-34
TO FILL THE HYDRAULIC FLUID		DEBRIS HOPPER	3-34
RESERVOIR	3-9	TO ADJUST HOPPER	3-34
HYDRAULIC FLUID RESERVOIR		STABILIZER LEG	3-38
BREATHER	3-10	TO ADJUST STABILIZER LEG	3-38
HYDRAULIC FLUID FILTER	3-10	BRUSHES	3-39
TO REPLACE THE HYDRAULIC		MAIN BRUSH	3-39
FLUID FILTER ELEMENT	3-10	TO REMOVE MAIN BRUSH	3-39
HYDRAULIC PUMPS	3-11	TO INSTALL MAIN BRUSH	3-39
TO START AND BREAK-IN		TO CHECK AND ADJUST MAIN	
HYDRAULIC PUMP	3-11	BRUSH PATTERN	3-40
DIRECTIONAL CONTROL PEDAL		SIDE BRUSH	
“NEUTRAL” POSITION ADJUSTMENT	3-11	3-41	
SPEED LIMITER	3-13	TO REMOVE SIDE BRUSH	3-41
HYDRAULIC FLUID LEAKS	3-13	TO INSTALL SIDE BRUSH	3-41
HYDRAULIC SCHEMATIC –		TO ADJUST SIDE BRUSH MAXIMUM	
LOW DUMP MODEL	3-14	RAISED HEIGHT	3-42
HYDRAULIC SCHEMATIC –		TO ADJUST SIDE BRUSH HEIGHT	
MULTI-LEVEL DUMP	3-15	ANGLE	3-42
HYDRAULIC SYSTEM		TO ADJUST SIDE BRUSH BUMPER	
TROUBLESHOOTING	3-16	CLEARANCE	3-43
HYDRAULIC COMPONENTS		SKIRTS AND SEALS	3-44
TROUBLESHOOTING	3-19	HOPPER LIP SKIRTS	3-44
ENGINE	3-20	TO REPLACE HOPPER LIP	3-44
LUBRICATION	3-20	HOPPER SIDE SEALS	3-44
COOLING SYSTEM	3-20	TO REPLACE HOPPER SIDE SEALS	3-44
AIR INTAKE SYSTEM	3-21	BRUSH DOOR SKIRTS	3-45
AIR FILTER SERVICE INDICATOR ..	3-21	TO REPLACE AND ADJUST BRUSH	
AIR FILTER	3-21	DOOR SKIRTS	3-45
TO REPLACE AIR FILTER ELEMENT	3-22	REAR SKIRTS	3-46
FUEL SYSTEM	3-23	TO REPLACE AND ADJUST	
FUEL WATER TRAP FILTER	3-23	REAR SKIRTS	3-46
TO REPLACE THE FUEL FILTER		HOPPER DUST DUMP DOOR SEAL ...	3-46
ELEMENT	3-23	TO REPLACE DUST DUMP	
FUEL INJECTION PUMP	3-24	DOOR SEAL	3-46
FUEL INJECTORS	3-24	TO CHECK AND ADJUST HOPPER	
PRIMING THE FUEL SYSTEM	3-24	DUST DUMP DOOR SEAL	3-47
TO PRIME FUEL SYSTEM	3-25		

	Page
TOP HOPPER SEAL – LOW DUMP	
MODEL	3-47
TO REPLACE TOP HOPPER SEAL ..	3-47
HINGED TOP HOPPER SEAL –	
MULTI-LEVEL DUMP MODEL	3-48
TO REPLACE AND ADJUST HINGED	
TOP HOPPER SEAL	3-48
HOPPER DOOR HINGE SEAL –	
MULTI-LEVEL DUMP MODEL	3-49
TO REPLACE HOPPER DOOR	
HINGE SEAL	3-49
LATCHES	3-50
HOPPER COVER LATCH	3-50
TO ADJUST HOPPER COVER LATCH	3-50
SIDE DOOR LATCHES	3-50
HOPPER INSPECTION DOOR LATCH ..	3-51
REAR ACCESS DOOR LATCH	3-51
BRAKES AND TIRES	3-52
SERVICE BRAKES	3-52
PARKING BRAKES	3-53
TIRES	3-53
OPTIONS	
3-54	
AIR FILTER OPTION	3-54
TO REPLACE AIR FILTER ELEMENT	3-54
SEVERE ENVIRONMENT AIR	
FILTER OPTION	3-55
TO REPLACE AIR FILTER ELEMENT	3-55
OPERATING LIGHTS OPTION	3-56
HEADLIGHT	3-56
SIDE BRUSH SPOTLIGHT	3-56
DUMPSTER SPOTLIGHT	3-57
DEBRIS DEFLECTOR SKIRTS OPTION .	3-57
SIDE BRUSH DUST CONTROL OPTION	3-57
APPENDIX	4-1
HARDWARE INFORMATION	4-3
STANDARD BOLT TORQUE CHART ...	4-3
METRIC BOLT TORQUE CHART	4-3
BOLT IDENTIFICATION	4-3
THREAD SEALANT AND LOCKING	
COMPOUNDS	4-3
HYDRAULIC FITTING INFORMATION	4-4
HYDRAULIC TAPERED PIPE FITTING (NPT)	
TORQUE CHART	4-4
HYDRAULIC TAPERED SEAT FITTING (JIC)	
TORQUE CHART	4-4
HYDRAULIC O–RING FITTING TORQUE	
CHART	
4-4	

	Page
LOW DUMP MODEL PARTS	
ORDERING REPAIR PARTS	5-3
Fig. 1 – Recommended General	
Maintenance Items	5-4
Fig. 2 – Replacement Brushes	5-5
Fig. 3 – Main Frame Group	5-6
Fig. 4 – Seat Support Group	5-8
Fig. 5 – Side and Rear Doors Group	5-10
Fig. 6 – Engine Hood Group	5-12
Fig. 7 – Lintel Group	5-13
Fig. 8 – Hopper Lift Arms Group	5-14
Fig. 9 – Bumper Group	5-15
Fig. 10 – Side Brush Group	5-16
Fig. 11 – Filter Box Assembly	5-18
Fig. 12 – Hopper Group	5-20
Fig. 13 – Vacuum Fan Group	5-22
Fig. 14 – Directional Control Group	5-23
Fig. 15 – Main Brush Lift and	
Drive Group	5-24
Fig. 16 – Front Wheels and	
Brakes Group	5-26
Fig. 17 – Steering Control Group	5-28
Fig. 18 – Overhead Guard Group	5-29
Fig. 19 – Rear Wheel Support Group	5-30
Fig. 20 – Rear Wheel Assembly	5-32
Fig. 21 – Instrument Panel Group	5-33
Fig. 22 – Air Cleaner Group	5-34
Fig. 23 – Engine Group	5-36
Fig. 24 – Throttle Linkage Group	5-38
Fig. 25 – Battery Group	5-39
Fig. 26 – Radiator Group	5-40
Fig. 27 – Fuel Tank Group	5-41
Fig. 28 – Alternator Group	5-42
Fig. 29 – Muffler Group	5-43
Fig. 30 – Hydraulic Hoses Group	5-44
Fig. 31 – Wire Harnesses Group,	
Low Dump	5-46
Fig. 32 – Control Valves Group	5-48
Fig. 33 – Hydraulic Pumps Group	5-49
Fig. 34 – Hydraulic Reservoir Group	5-50
Fig. 35 – Counterweight Group	5-51
Fig. 36 – Labels Group	5-52

GENERAL INFORMATION

	Page
MULTI-LEVEL DUMP MODEL PARTS	
ORDERING REPAIR PARTS	6-3
Fig. 1 – Main Frame Group, Multi–Level Dump	6-4
Fig. 2 – Stabilizer Leg Assembly, Multi–Level Dump	6-5
Fig. 3 – Hopper Lift Arms Group, Multi–Level Dump	6-6
Fig. 4 – Lintel Group, Multi–Level Dump . .	6-7
Fig. 5 – Hopper Group, Multi–Level Dump	6-8
Fig. 6 – Hopper Hinged and Dump Doors Group, Multi–Level Dump . . .	6-10
Fig. 7 – Speed Limiter Assembly, Multi–Level Dump	6-12
Fig. 8 – Instrument Panel Group, Multi–Level Dump	6-13
Fig. 9 – Rear Wheel Assembly, Multi–Level Dump	6-13
Fig. 10 – Hydraulic Hoses Group, Multi–Level Dump	6-14
Fig. 11 – Lift and Dump Cylinders Group, Multi–Level Dump	6-16
Fig. 12 – Control Valve Group, Multi–Level Dump	6-17
Fig. 13 – Wire Harness Group, Multi–Level Dump	6-18

	Page
ACCESSORIES	
ORDERING REPAIR PARTS	7-3
Fig. 1 – Flashing Light Kit, Left Rear Corner	7-4
Fig. 2 – Revolving Light Kit, Left Rear Corner	7-5
Fig. 3 – Flashing Light Kit, Overhead Guard and Cab	7-6
Fig. 4 – Revolving Light Kit, Overhead Guard and Cab . . .	7-7
Fig. 5 – Operating Lights Kit	7-8
Fig. 6 – Cab Group	7-10
Fig. 7 – Cab Door Group	7-12
Fig. 8 – Heater Defroster Kit, Diesel	7-14
Fig. 9 – Snow Blade Adapter Kit	7-15
Fig. 10 – Snow Blade Kit	7-16
Fig. 11 – Vacuum Wand Kit	7-18
Fig. 12 – Air Cleaner Kit	7-20
Fig. 13 – Air Filter Intake Kit, Diesel	7-22
Fig. 14 – Debris Deflector Kit	7-23
Fig. 15 – Hopper Dolly Kit, Low Dump, Multi–Level Dump	7-24
Fig. 16 – Hopper Dolly Kit, SE	7-24
Fig. 17 – Fire Extinguisher Kit	7-25
Fig. 18 – Protectoseal Fuel Tank Cap	7-25
Fig. 19 – Thermostat Assembly	7-26
Fig. 20 – Speed Control Kit	7-26
Fig. 21 – Rear Wheel Kit, Low Dump	7-27
Fig. 22 – Urethane Tire Kit	7-27
Fig. 23 – Back–Up Alarm Kit	7-28
Fig. 24 – Seat Belt Kit	7-29
Fig. 25 – Front Bumper Group, SE	7-30
Fig. 26 – Rear Bumper Group, SE	7-30
Fig. 27 – Neutral Start Switch Group, SE . .	7-31
Fig. 28 – Air Cleaner Group, SE	7-32
Fig. 29 – Alternator Group, Diesel, SE	7-34
Fig. 30 – Auxiliary Side Brush Pivot Group	7-35
Fig. 31 – Auxiliary Side Brush Group	7-36
Fig. 32 – Auxiliary Side Brush Bumper and Hydraulics Group	7-38

	Page
HYDRAULIC COMPONENTS	
ORDERING REPAIR PARTS	8-3
Fig. 1 – Hydraulic Pump Breakdown, 35730	8-4
Fig. 2 – Accessories Pump Breakdown, 35490	8-6
Fig. 3 – Motor Breakdown, 75025	8-7
Fig. 4 – Hydraulic Motor Breakdown, 27800	8-8
Fig. 5 – Hydraulic Motor Breakdown, 19349	8-9
Fig. 6 – Hydraulic Solenoid Valve Breakdown, 35491	8-10
Fig. 7 – Hydraulic Solenoid Valve Breakdown, 35492	8-11
Fig. 8 – Motor Breakdown, 77101	8-12
Fig. 9 – Cylinder Breakdown, 04443	8-13
Fig. 10 – Cylinder Breakdown, 34326	8-14
Fig. 11 – Cylinder Breakdown, 34327	8-15

ENGINE PARTS

ORDERING REPAIR PARTS	9-3
Fig. 1 – Engine Block Group	9-4
Fig. 2 – Cylinder Head Group	9-6
Fig. 3 – Gear Case Group	9-8
Fig. 4 – Oil Pan Group	9-10
Fig. 5 – Main Bearing Case Group	9-11
Fig. 6 – Inlet Manifold Group	9-12
Fig. 7 – Camshaft Group	9-13
Fig. 8 – Valve Rocker Arm Group	9-14
Fig. 9 – Head Cover Group	9-16
Fig. 10 – Piston Crankshaft Group	9-18
Fig. 11 – Flywheel Group	9-20
Fig. 12 – Fuel Camshaft Group	9-21
Fig. 13 – Nozzle Holder Group	9-22
Fig. 14 – Speed Control Plate Group	9-24
Fig. 15 – Engine Stop Lever Group	9-25
Fig. 16 – Governor Group	9-26
Fig. 17 – Water Pump Group	9-27
Fig. 18 – Injection Pump Group	9-28
Fig. 19 – Water Flange Group	9-29

	Page
CROSS REFERENCE	10-1
PART NUMBER TO PAGE NUMBER CROSS REFERENCE LIST	10-3
CUSTOMER DOCUMENTS	11-1
TENNANT COMPANY LIMITED WARRANTY	11-3
TENNANT COMPANY, TENNANT COMPANY SUBSIDIARIES, AND MAJOR PARTS AND SERVICE LOCATIONS DIRECTORY	11-5

SECTION 1**CONTENTS**

	Page
MACHINE SPECIFICATIONS	1-3
POWER TYPE	1-3
POWER TRAIN	1-3
STEERING	1-3
HYDRAULIC SYSTEM	1-3
BRAKING SYSTEM	1-4
SUSPENSION SYSTEM	1-4
SYSTEM FLUID CAPACITIES	1-4
GENERAL MACHINE DIMENSIONS – CAPACITIES	1-4
MACHINE WEIGHTS	1-4
GENERAL MACHINE PERFORMANCE	1-4
MACHINE DIMENSIONS	1-5

MACHINE SPECIFICATIONS

POWER TYPE

Engine Manufacturer/model – Kubota V1902
 Engine type – piston
 Ignition – diesel
 Cycle – 4
 Aspiration – natural
 Cylinders – 4
 Bore – 3.35 in (85 mm)
 Stroke – 3.23 in (82 mm)
 Displacement – 113.57 cu in (1861 cc)
 Net power – 34 hp (25.4 kw) @ 2200 rpm governed
 43 hp (32 kw) @ 2800 rpm maximum
 Fuels – #2 diesel fuel
 Cooling system – water
 Electrical system – 12 V nominal, 37 A alternator,
 low dump, multi-level dump
 30 A totally enclosed alternator, severe
 environment option

POWER TRAIN

Propelling – hydraulic drive motor, rear wheel
 Main brush – hydraulic drive motor
 Side brush – hydraulic drive motor
 Vacuum fan – hydraulic drive motor

STEERING

Type – rear wheel controlled, automotive cam and
 lever
 Power source – manual
 Emergency steering – manual

HYDRAULIC SYSTEM

Function – operates propelling, hopper lift, hopper
 dump, main brush drive, side brush drive, and
 vacuum fan drive.

Control valve, low dump model, hopper lift, main
 brush drive, side brush drive, vacuum fan drive
 – solenoid operated.

Control valve, multi-level dump model, hopper lift,
 hopper dump, main brush drive, side brush
 drive, vacuum fan drive – solenoid operated.

Propelling pump – variable displacement piston
 pump, 22.7 gpm (86 L/min) @ 2400 rpm

Propelling system rated pressure – 4500 psi
 (31,030 kPa)

Accessories pump – gear pump, 14.3 gpm
 (54 L/min) @ 2400 rpm.

Accessories system rated pressure – 2000 psi
 (13,790 kPa)

Hopper door cylinder system rated pressure – 500
 psi (3450 kPa).

Propelling motor – internal gear motor, 29.9 cu in
 (490 cc) displacement per revolution.
 4500 psi (31,030 kPa) maximum rated
 pressure.

Main brush motor – internal gear motor, 4.5 cu in
 (74 cc) displacement per revolution. 2400 psi
 (16,550 kPa) maximum rated pressure.

Side brush motor – internal gear motor,
 5.9 cu in (97 cc) displacement per revolution.
 2500 psi (17,240 kPa) maximum rated
 pressure.

Vacuum fan motor – external gear motor,
 0.26 cu in (4 cc) displacement per revolution.
 3000 psi (20,685 kPa) maximum rated pressure

Hopper lift cylinder, low dump model – double
 action, 3 in (75 mm) bore x 11.8 in
 (300 mm) stroke, 1.37 in (35 mm) diameter rod,
 2500 psi (17,240 kPa) maximum rated
 pressure.

Hopper lift cylinder, multi-level dump model –
 double action, 3.5 in (90 mm) bore x 20.7 in
 (525 mm) stroke, 1.5 in (40 mm) diameter rod,
 2500 psi (17,240 kPa) maximum rated
 pressure.

Hopper dump cylinder, multi-level dump model (2)
 – double action, 2 in (51 mm) bore x 12 in (305
 mm) stroke, 1 in (25 mm) diameter rod, 2500
 psi (17,240 kPa) maximum rated pressure.

SPECIFICATIONS

BRAKING SYSTEM

Service brakes – hydraulic drum brakes (2), one per front wheel, foot brake master cylinder actuated

Parking brakes – utilizes service brakes, cable actuated

SUSPENSION SYSTEM

Front – two 21 x 5 x 12 solid tires

Rear, low dump model – one 6.90/6.00 x 9 pneumatic tire

Rear, multi-level dump model – one 6.90/6.00 x 9 solid tire

SYSTEM FLUID CAPACITIES

Engine cooling system – radiator 7.4 qt (7 L)

Engine cooling system – total system 14.6 qt (13.8 L)

Engine lubricating oil – 8.38 qt (9 L) with filter

Fuel tank – 12.9 gal (50 L)

Hydraulic system – reservoir 5 gal (19 L) total system 7 gal (26 L)

GENERAL MACHINE DIMENSIONS – CAPACITIES

Length – 111.5 in (2830 mm)

Width – 71 in (1805 mm)

Height, without overhead guard – 59 in (1500 mm)

Height, with overhead guard – 81.5 in (2070 mm)

Height, with overhead guard and hazard light – 90.5 in (2300 mm)

Track – front, 60.5 in (1535 mm)

Wheel base – 48.9 in (1240 mm)

Main brush, tubular diameter – 16 in (405 mm)
tubular length – 50 in (1270 mm)

Side brush, rotary diameter – 26 in (660 mm)

Sweeping path width, without side brush – 50 in (1270 mm)

Sweeping path width, with side brush – 66 in (1676 mm)

Sweeping path width, with auxiliary side brush option – 84 in (2135 mm)

Hopper capacity – 1800 lb (815 kg) 30 cu ft (0.85 m³)

Dust filter area – 120 sq ft (11 m²)

MACHINE WEIGHTS

Net GVWR, low dump model – 6670 lb (3025 kg)

Net GVWR, multi-level dump model – 6950 lb (3155 kg)

GENERAL MACHINE PERFORMANCE

Maximum forward speed – 10.7 mph (17 km/h)

Maximum reverse speed – 6 mph (10 km/h)

Turning radius, right – 91.5 in (2325 mm)

Turning radius, left – 70.75 in (1795 mm)

MACHINE DIMENSIONS

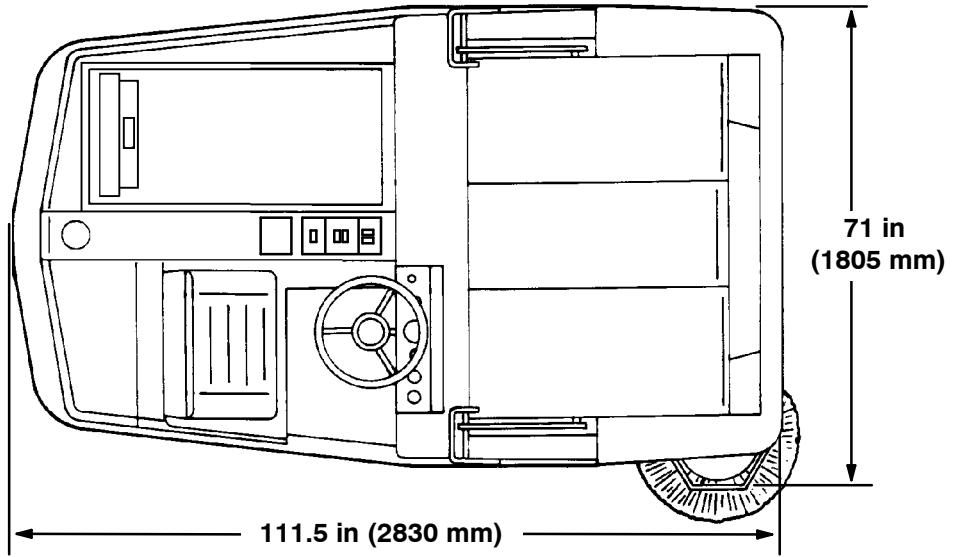

TOP VIEW

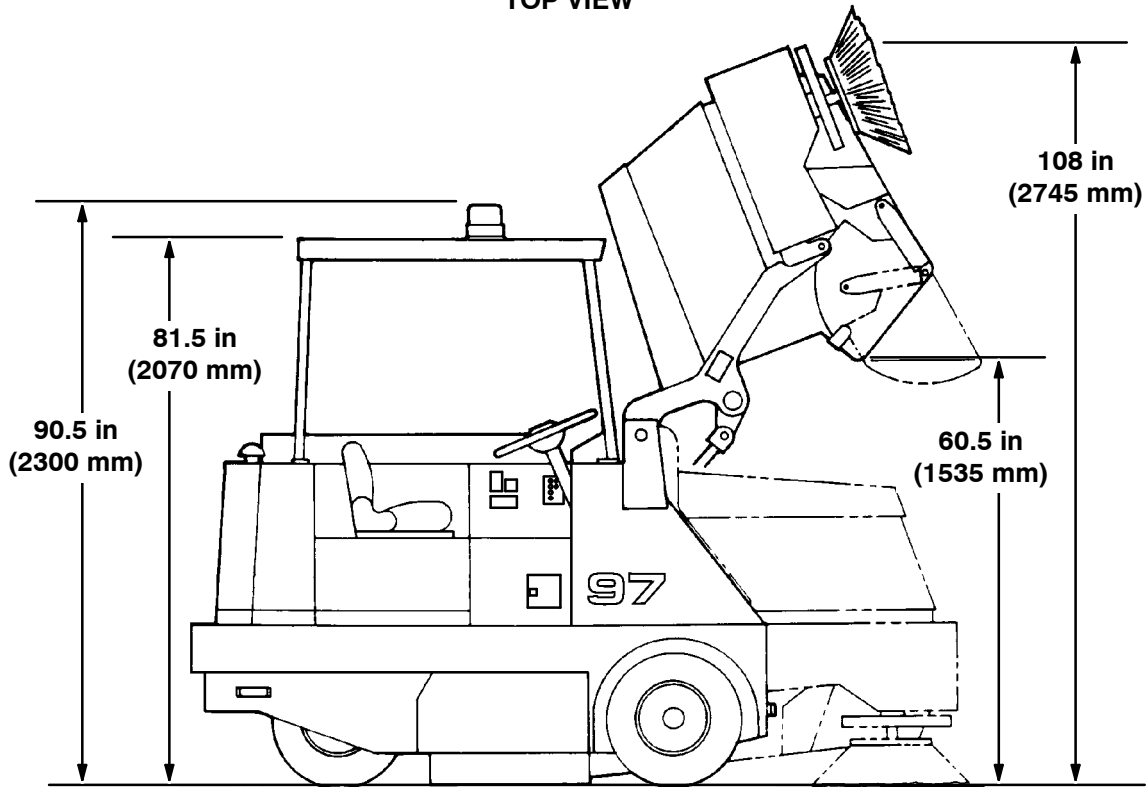

SIDE VIEW

06716

SECTION 2

CONTENTS

	Page		Page
PREPARATION FOR OPERATION	2-3	MACHINE OPERATION	2-12
AFTER UNCRATING AND BEFORE OPERATING		NORMAL SWEEPING OPERATION	2-12
THE MACHINE:	2-3	PRE-START CHECKLIST	2-12
OPERATION OF CONTROLS	2-4	TO START MACHINE	2-12
MACHINE COMPONENTS	2-4	TO SWEEP	2-12
INSTRUMENT PANEL SYMBOLS	2-4	TO DUMP LOW DUMP HOPPER	2-13
CONTROLS AND INSTRUMENTS	2-6	TO DUMP MULTI-LEVEL DUMP HOPPER ...	
BRAKE PEDAL	2-7	2-14	
DIRECTIONAL PEDAL	2-7	POST OPERATION CHECKLIST –	
MAIN BRUSH HEIGHT ADJUSTMENT KNOB ..		ENGINE OPERATING	2-14
2-7		TO STOP MACHINE	2-15
OPERATOR SEAT	2-8	POST OPERATION CHECKLIST –	
THROTTLE LEVER	2-8	ENGINE STOPPED	2-15
MAIN BRUSH SWITCH	2-8	TO ENGAGE LOW DUMP MODEL	
SIDE BRUSH SWITCH	2-8	HOPPER SUPPORT BAR	2-15
FILTER SHAKER AND VACUUM		TO DISENGAGE LOW DUMP MODEL	
FAN SWITCH	2-8	HOPPER SUPPORT BAR	2-16
HOPPER DOOR SWITCH	2-9	TO ENGAGE MULTI-LEVEL DUMP	
HOPPER SWITCH	2-9	MODEL HOPPER SUPPORT BAR	2-16
CIRCUIT BREAKERS	2-9	TO DISENGAGE MULTI-LEVEL DUMP	
MAIN BRUSH POSITION LEVER	2-9	MODEL HOPPER SUPPORT BAR	2-17
OPERATING LIGHTS SWITCH	2-9	OPERATION ON GRADES	2-17
HAZARD LIGHT SWITCH	2-10	OPTION OPERATION	2-18
TURN SIGNAL SWITCH	2-10	VACUUM WAND OPTION	2-18
HOPPER DOOR LAMP	2-10	TO OPERATE VACUUM WAND	2-18
CLOGGED DUST FILTER LAMP	2-10	HOPPER DOLLY OPTION	2-19
FUEL LEVEL GAUGE	2-10	TO REMOVE HOPPER WITH DOLLY ...	2-19
HIGH ENGINE COOLANT		TO REINSTALL HOPPER WITH DOLLY .	2-20
TEMPERATURE LAMP	2-10	HEATER/DEFROSTER OPTION	2-20
ENGINE COOLANT TEMPERATURE GAUGE ..		SNOW BLADE OPTION	2-21
2-10		TO INSTALL SNOW BLADE	2-21
STEERING WHEEL	2-10	TO OPERATE SNOW BLADE	2-22
LOW ENGINE OIL PRESSURE LAMP	2-10	TO REMOVE SNOW BLADE	2-23
ENGINE OIL PRESSURE GAUGE	2-10	MACHINE TROUBLESHOOTING	2-24
VOLTAGE GAUGE	2-10	TRANSPORTING MACHINE	2-25
HOUR METER	2-11	PUSHING OR TOWING MACHINE	2-25
KEY-OPERATED IGNITION SWITCH	2-11	MACHINE JACKING INSTRUCTIONS	2-25
PARKING BRAKE	2-11	MACHINE TIE-DOWN INSTRUCTIONS	2-26
SIDE BRUSH HEIGHT ADJUSTMENT KNOB ...		MACHINE STORAGE	2-27
2-11		STORING MACHINE	2-27
HOPPER SUPPORT BAR	2-11		
STABILIZER LEG	2-11		

PREPARATION FOR OPERATION

AFTER UNCRATING AND BEFORE OPERATING THE MACHINE:

1. Check the machine for shipping damage.
2. Read this manual carefully before operating or servicing the machine.

FOR SAFETY: Do Not Operate The Machine, Unless Operation Manual Is Read And Understood.

3. Check the hydraulic fluid level in the hydraulic fluid reservoir using the dipstick provided. TENNANT hydraulic fluid is recommended. If TENNANT hydraulic fluid is not available, use only new-approved hydraulic fluid. See *HYDRAULICS* in the *MAINTENANCE* section.
4. Check the engine oil level.
5. Check the radiator coolant level.

FOR SAFETY: When Servicing Machine, Avoid Contact With Hot Engine Coolant.

6. Check the brush adjustment, as described in *MAINTENANCE* section.
7. Check the air pressure of the rear tire, low dump model only.
8. Fill the fuel tank per the instructions in this manual.

FOR SAFETY: When Servicing Machine, Keep Flames And Sparks Away From Fuel System Service Area. Keep Area Well Ventilated.

OPERATION OF CONTROLS

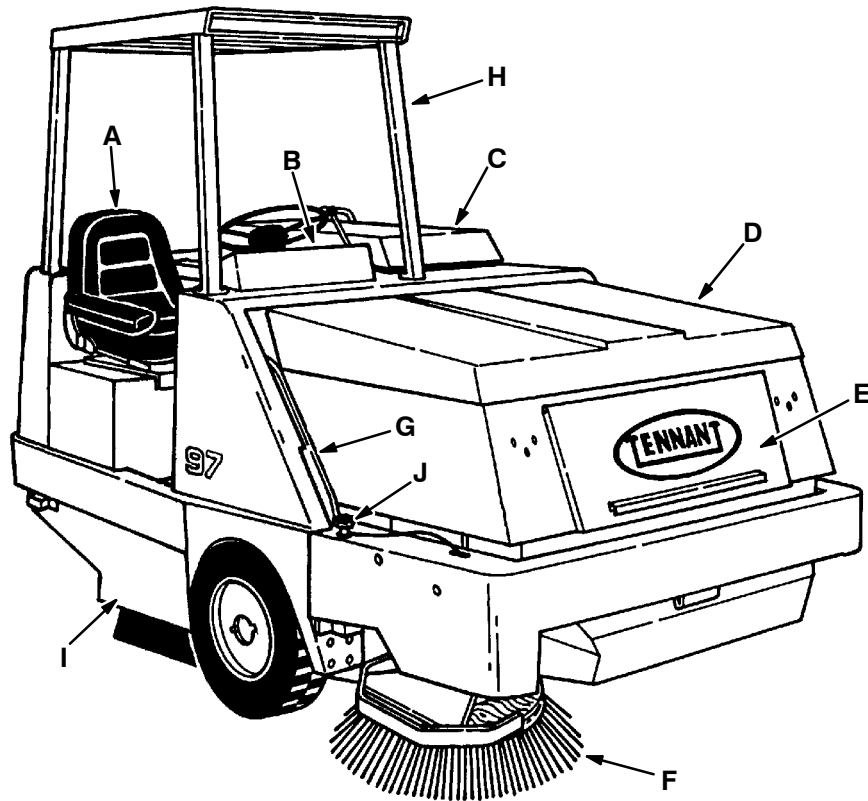

MACHINE COMPONENTS

06461

- | | |
|------------------------------|---|
| A. Operator Seat | F. Side Brush |
| B. Instrument Panel | G. Hopper Support Arm |
| C. Engine Cover | H. Overhead Guard |
| D. Hopper | I. Main Brush Access Door |
| E. Hopper Access Door | J. Side Brush Height Adjustment Knob |

INSTRUMENT PANEL SYMBOLS

The symbols are used to identify controls and displays on the machine:



Slow



Fast



Main Brush Off



Main Brush #1



Main Brush #2



Side Brush Off



Side Brush On



Filter Shaker



Vacuum Fan



Hopper Door Close



Hopper Door Open



Hopper Up



Hopper Hold



Hopper Down



Circuit Breaker #1



Circuit Breaker #2



Circuit Breaker #3



Circuit Breaker #4



Circuit Breaker #5



Circuit Breaker #6



Circuit Breaker #7



Circuit Breaker #8



Main Brush Free-float



Main Brush Down



Main Brush Up



Filter Clogged



Operating Lights



Hazard Light



Engine Water Temperature



Engine Oil Pressure



Key Switch



Diesel Fuel



Hydraulic Fluid

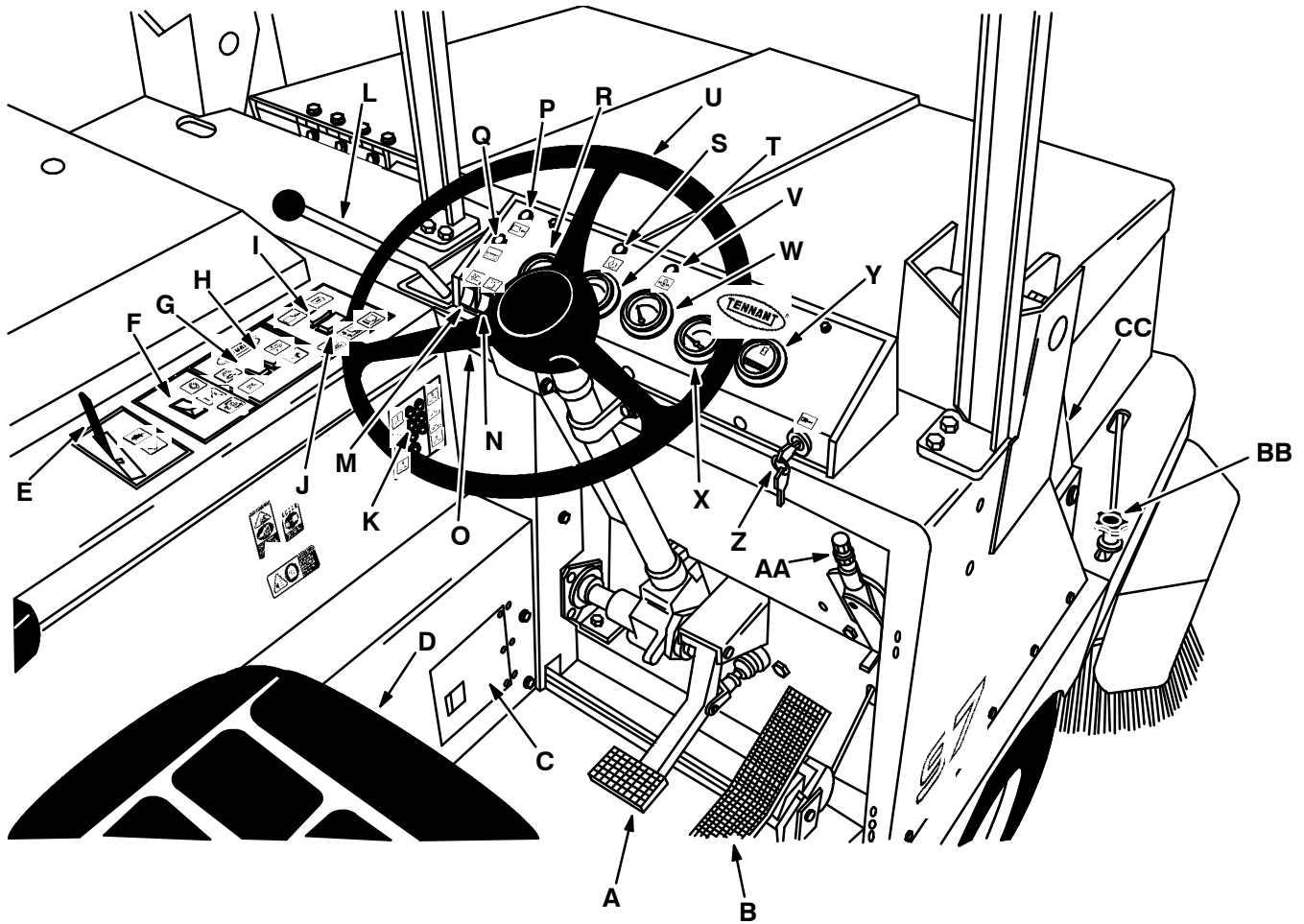

CONTROLS AND INSTRUMENTS

06559

- | | |
|--|--|
| A. Brake Pedal | N. Hazard Light Switch |
| B. Directional Pedal | O. Turn Signal Switch |
| C. Main Brush Height Adjustment Knob | P. Hopper Door Lamp, Multi-Level Dump |
| D. Operator Seat | Q. Clogged Dust Filter Lamp |
| E. Throttle Lever | R. Fuel Level Gauge |
| F. Main Brush Switch | S. High Engine Coolant Temperature Lamp |
| G. Side Brush Switch | T. Engine Coolant Temperature Gauge |
| H. Filter Shaker and Vacuum Fan Switch | U. Steering Wheel |
| I. Hopper Door Switch, Multi-Level Dump | V. Low Engine Oil Pressure Lamp |
| J. Hopper Switch | W. Engine Oil Pressure Gauge |
| K. Circuit Breakers | X. Voltage Gauge |
| L. Main Brush Position Lever | Y. Hour Meter |
| M. Operating Lights Switch | Z. Key Switch |
| | AA. Parking Brake |
| | BB. Side Brush Height Adjustment Knob |
| | CC. Hopper Support Bar |

BRAKE PEDAL

The brake pedal operates the mechanical drum brakes on the two front wheels.

To stop the machine, return the directional pedal to neutral; then apply pressure to the brake pedal.

DIRECTIONAL PEDAL

The directional pedal controls the propelling drive. The foot pedal is used to select the direction of travel and the propelling speed of the machine.

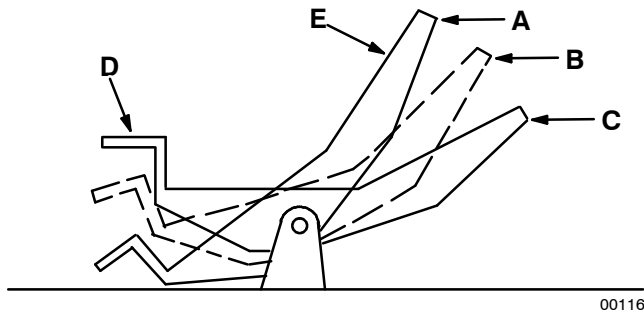

- A. "Reverse" Position
- B. "Neutral" Position
- C. "Forward" Position
- D. "Heel" Portion
- E. "Toe" Portion

To travel forward, press the "toe" portion of the pedal; press the "heel" portion of the pedal for reverse travel. The propelling speed of the machine is regulated by varying the pressure on the pedal.

If the machine creeps when the pedal is in the neutral position, adjust the pedal as directed in *DIRECTIONAL PEDAL "NEUTRAL" POSITION ADJUSTMENT* in the *MAINTENANCE* section.

MAIN BRUSH HEIGHT ADJUSTMENT KNOB

The main brush height adjustment knob is located behind an access door next to the operator's left foot. The height adjustment knob adjusts the main brush pattern width.

Threading the knob to the right reducing the main brush floor contact, decreasing the brush pattern width. Threading the knob to the left increases main brush floor contact, increasing the brush pattern width.

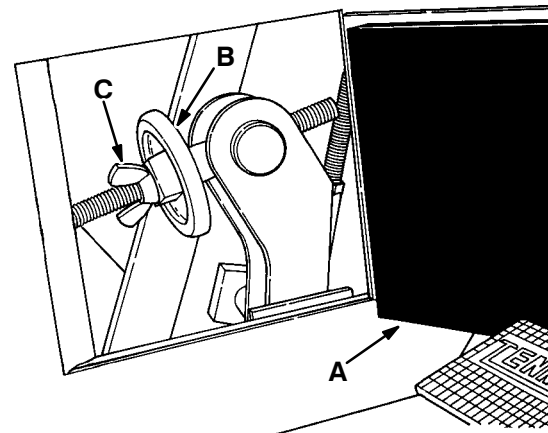

MAIN BRUSH HEIGHT ADJUSTMENT KNOB

- A. Access Door
- B. Adjustment Knob
- C. Wing Nut

OPERATION

OPERATOR SEAT

The operator seat is a three-way adjustable seat with armrests. The seat has adjustments to compensate for operator weight, to vary the backrest angle, and to vary the front to rear seat position.

The weight adjustment lever has three positions. One for light operators, one for medium weight operators, and one for heavy operators. Pull the lever up for light operators, position the lever horizontally for medium weight operators, and down for heavy operators.

The backrest angle is adjusted by rotating the knob to the right to decrease the backrest angle, or to the left to increase the backrest angle.

The seat position is adjusted by pulling the seat position lever out, sliding the seat forward or backward to a comfortable position, and releasing the lever.

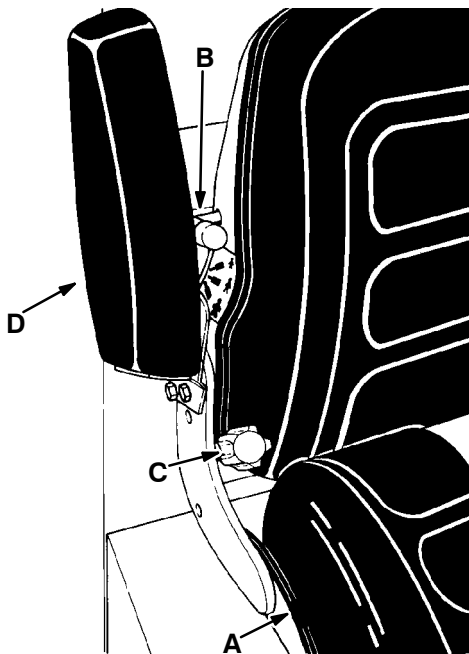

The right side armrest may be rotated up and back to enter or exit from the operator seat.



OPERATOR SEAT



- A. Seat
- B. Weight Adjustment Lever
- C. Backrest Angle Knob
- D. Armrest

THROTTLE LEVER

The throttle lever controls the engine governed speed. To slow the engine to idle speed, push the lever forward into the  (Slow) position. To speed the engine to the maximum governed speed, pull the lever back into the  (Fast) position. To stop the engine, push the lever all the way forward past the (Slow) position.

MAIN BRUSH SWITCH



The main brush switch controls the main brush speed and rotation.

To start the main brush rotation, place the switch in the middle  (Main Brush #1) position for sweeping normal debris. Place the switch in the bottom  (Main Brush #2) position for sweeping light litter.

To stop the main brush rotation, place the switch in the top  (Main Brush Off) position.

SIDE BRUSH SWITCH

The side brush switch lowers and starts, and raises and stops the side brush.

To lower and start the side brush, press and hold the switch in the bottom  (Side Brush On) position until the side brush lowers the desired height. To raise and stop the side brush, press and hold the switch in the top  (Side Brush Off) position.

FILTER SHAKER AND VACUUM FAN SWITCH

The filter shaker and vacuum fan switch turns on the filter shaker and vacuum fan.

To turn on the vacuum fan, place the switch in the bottom  (Vacuum Fan) position. To turn off the vacuum fan, place the switch in the middle position.



To start the filter shaker, press the top  (Filter Shaker) of the switch. The filter shaker will automatically run for 40 seconds.

NOTE: The main brush and vacuum fan will not run while the filter shaker is operating. Once the filter shaker stops, the main brush and vacuum fan can be operated.

01435

HOPPER DOOR SWITCH



The hopper door switch is present on multi-level dump machines. The switch controls the hopper door position.

To open the hopper door into the sweeping and dumping position, press and hold the switch in the  (Hopper Door Open) position. To close the hopper door so the hopper may be raised without allowing debris to spill out, press and hold the switch in the  (Hopper Door Close) position.

Always sweep with the hopper door open in the sweeping position.

NOTE: The hopper door has to be open to sweep. The hopper door lamp lights if the hopper door is not fully open. The lamp will go out when the hopper door is fully open.

HOPPER SWITCH

The hopper switch controls the hopper position. To raise the hopper, press and hold the switch in the  (Hopper Up) position until the hopper reaches the desired height. To stop and hold the hopper at the desired height, release the switch in the  (Hopper Hold) position. To lower the hopper, press and hold the switch in the  (Hopper Down) position.

 **WARNING: Falling Hopper. Engage Hopper Support Bar Before Working Under Hopper.**

CIRCUIT BREAKERS

Circuit breakers are reusable circuit protection devices designed to stop the flow of current in the event of a circuit overload. Once tripped, circuit breakers must cool before they are reset by pressing the reset button. The circuit breakers are located on the driver compartment panel to the left of the steering wheel.

If the overload which caused the circuit breaker to trip is still present in the circuit, the circuit breaker will continue to stop current flow until the overload is corrected. The chart below shows the various circuit breakers and the electrical components they protect.

PROTECTIVE DEVICE	RATING	CIRCUIT PROTECTED
CB-1	15 A	Filter Shaker, Control Valve
CB-2	15 A	Side Brush Actuator
CB-3	15 A	Instrumentation and Hopper Switches
CB-4	15 A	Operating Lights
CB-5	15 A	Turn Signal
CB-6	15 A	Cab Heater/Defroster, Wiper
CB-7	15 A	Back-Up Alarm
CB-8	15 A	Auxiliary Side Brush

MAIN BRUSH POSITION LEVER

The main brush position lever controls the position of the main brush. There are two operating positions for the main brush, normal and free-float. The normal position is used for most sweeping conditions, and will extend main brush life. The free-float position is used when sweeping extremely uneven areas, and allows the main brush to follow the surface more closely.

To lower the main brush for normal sweeping, pull the lever back and to the right into the  (Main Brush Down) position.

To lower the main brush for sweeping extremely uneven surfaces, pull the lever back and to the right into the  (Main Brush Free-Float) position.

To raise the main brush, pull the lever all the way back then to the left into the  (Main Brush Up) position.

NOTE: Always raise the main brush when the machine is not being operated for a period of time to prevent the main brush from taking a set.

OPERATING LIGHTS SWITCH

The operating lights switch  is present on machines with the operating lights option. The switch controls the headlights, taillights, and the side brush spot lamp.

To turn on the lights, place the switch in the top position. To turn off the lights, place the switch in the bottom position.

OPERATION

HAZARD LIGHT SWITCH

The hazard light switch  is present on machines with the hazard light option. To turn on the light, place the switch in the top position. To turn off the light, place the switch in the bottom position.

TURN SIGNAL SWITCH

The turn signal switch is present on machines with the operating lights option. The switch controls the turn signal lights. To signal a right turn, push the turn signal switch lever forward. To signal a left turn, pull the signal switch lever back. To turn on the flashers, pull out the knob under the switch lever.

HOPPER DOOR LAMP

The hopper door lamp  is present on multi-level dump model machines. The lamp lights when the hopper dump door is not fully open. The dump door should be fully open and door lamp off whenever sweeping up debris. The hopper door should be closed when raising the hopper to dump the debris. Do not sweep with the dump door indicating lamp lit.

NOTE: The hopper door has to be open to sweep. The hopper door lamp lights if the hopper door is not fully open. The lamp will go out when the hopper door is fully open.

CLOGGED DUST FILTER LAMP

The clogged dust filter indicating lamp  lights when the dust filters become clogged and excessively restrict vacuum air flow. Lower the hopper, and press the filter shaker and vacuum fan switch in the (Filter Shaker) position to shake the dust filter. Shake the dust filters when necessary to remove the air restriction. It may be necessary to clean or replace the dust filters to remove the air restriction. Do not continue to sweep with the clogged dust filter lamp lighted as dust pickup will be reduced.

FUEL LEVEL GAUGE

The fuel level gauge indicates how much fuel is left in the fuel tank.

HIGH ENGINE COOLANT TEMPERATURE LAMP

The high engine coolant temperature lamp  is present on machines with the severe environment option. The lamp lights when the engine coolant temperature exceeds 225° F (107° C).

ENGINE COOLANT TEMPERATURE GAUGE

The engine coolant temperature gauge registers the engine coolant temperature. Normal engine coolant temperatures range up to 200° F (93° C). Temperatures above this level indicate an over-heating engine. This condition may be the result of a low coolant level, a clogged radiator, a loose fan belt, a defective thermostat, or other engine malfunctions. Engine overheating will always cause a coolant loss. If coolant loss does not occur, check for malfunction of the temperature sending unit.

STEERING WHEEL

The automotive-type steering wheel operates the rear wheel. The machine is very responsive to the movement of the steering wheel. Use care until you become more experienced in guiding the machine.

LOW ENGINE OIL PRESSURE LAMP

The low engine oil pressure lamp  is present on machines with the severe environment option. The lamp lights when the engine oil pressure drops below 7 psi (50 kPa).

ENGINE OIL PRESSURE GAUGE

This gauge registers the engine oil pressure. Normal engine oil pressure ranges from 7 psi (50 kPa) at idle, to 30 to 40 psi (205 to 275 kPa) at full engine throttle. The oil pressure may read as high as 60 psi (415 kPa) during cold engine start-up. If the gauge registers an oil pressure reading below 7 psi (50 kPa), stop the engine immediately and determine the cause. Failure to stop the engine will result in severe engine damage.

VOLTAGE GAUGE

The voltage gauge indicates the present voltage potential of the battery. Normal battery voltage is 10 to 14 volts. If the battery voltage exceeds 14 volts, it may be overcharging. If the battery voltage falls below 10 volts, it may not be accepting or getting a charge from the alternator. Overcharging and undercharging are indications that one or more electrical components is in need of repair.

HOUR METER

The hour meter records the number of hours the machine has been operated. This information is useful in determining when to service the machine.

KEY-OPERATED IGNITION SWITCH

The key-operated ignition switch  starts the engine.

To start the pre-heat, turn the key all the way to the left and hold the key there for 15 to 60 seconds, depending on weather conditions. To start the engine, turn the key fully to the right. Release the key as soon as the engine starts. To turn the engine off, turn the key to the left.

PARKING BRAKE

The parking brake operates the two front wheel brakes. Pulling the brake handle up sets the parking brake. Pushing the brake handle down releases the parking brake. Always set the parking brake before leaving the machine unattended and before working on the machine.

SIDE BRUSH HEIGHT ADJUSTMENT KNOB

The side brush height adjustment knob is located just above the side brush on the front bumper. Loosening the knob and sliding it forward lowers the side brush, increasing the brush contact with the floor. Sliding the knob backward raises the side brush, decreasing the brush contact with the floor. Tighten the knob after setting the side brush height. The side brush should be raised before making an adjustment.

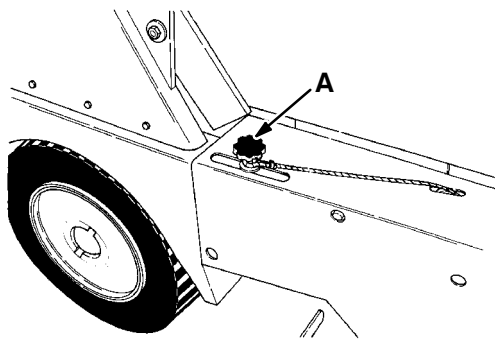

06717

SIDE BRUSH HEIGHT ADJUSTMENT KNOB

- A. Adjustment Knob**
- B. Side Bumper**

HOPPER SUPPORT BAR

The hopper support bar is present on the operator's side of the hopper to hold the hopper in a raised position for a length of time to allow work to be done under the hopper. Do not rely on the machine hydraulic system to keep the hopper raised.

 **WARNING: Falling Hopper. Engage Hopper Support Bar Before Working Under Hopper.**

STABILIZER LEG

The machine stabilizer leg is present on a multi-level dump model machine.

The stabilizer leg is a safety device which, when the machine is being multi-level dumped, projects forward to act as an anti-tipping device. Check the stabilizer leg to be sure it is projecting forward when the machine is being multi-level dumped and is fully retracted when the hopper is lowered position.

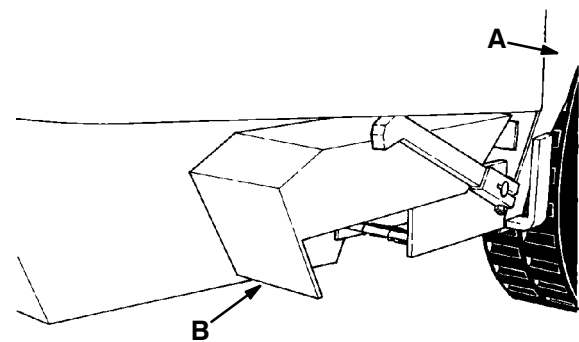

01440

RETRACTED STABILIZER LEG

- A. Machine Frame**
- B. Stabilizer Leg**

MACHINE OPERATION

NORMAL SWEEPING OPERATION

A normal sweeping operation consists of seven typical operations: pre-start checklist, starting machine, sweeping, dumping hopper, post operation checklist – engine operating, stopping machine, and post operation checklist – engine stopped.

The *PRE-START CHECKLIST* lists things to check before starting the machine.

TO START MACHINE lists the steps required to start the machine.

TO SWEEP lists things to keep in mind before and during the sweeping operation.

TO DUMP LOW DUMP HOPPER lists the steps required to dump the low dump hopper.

TO DUMP MULTI-LEVEL DUMP HOPPER lists the steps required to dump the multi-level dump hopper.

POST OPERATION CHECKLIST – ENGINE OPERATING lists things to check before stopping the machine engine.

TO STOP MACHINE lists the steps required to stop the machine.

POST OPERATION CHECKLIST – ENGINE STOPPED lists things to check after stopping the machine engine.

PRE-START CHECKLIST

Check under the machine for leak spots.

Check the engine lubricating oil level.

Check the radiator coolant level.

Remove and clean the radiator screen.

Drain the water trap.

Check the fuel level.

Check the brakes and controls for proper operation.

Check the service records to determine service requirements.

TO START MACHINE

NOTE: Before starting machine, perform the pre-start checks.

FOR SAFETY: Before Starting Machine, Make Sure All Safety Devices Are In Place And Operate Properly.

1. The machine operator must be in the operator's seat with the directional pedal in the "neutral" position, and with a foot on the brake pedal or with the parking brake set.
2. If the engine is cold: Turn the switch key fully to the left, to start the diesel pre-heat, and hold the key there for 30 seconds.
3. Move the throttle lever to the (Slow) position.
4. Turn the ignition switch key to the right until the engine starts. Do not operate the starter for more than a few seconds at a time, or after the engine has started.

NOTE: Do not operate the starter motor for more than 10 seconds at a time or after the engine has started. Allow the starter to cool between starting attempts. The starter motor may be damaged if it is operated incorrectly.

5. Allow the engine and hydraulic system to warm up three to five minutes.
6. Release the machine parking brake.
7. Move the throttle lever to the (Fast) position, and drive the machine to the area to be swept.

TO SWEEP

Plan the sweeping in advance. Try to arrange long runs with minimum stopping and starting. Sweep debris from very narrow aisles into main aisles ahead of time. Do an entire floor or section at one time.

Pick up oversize debris before sweeping. Flatten or remove bulky cartons from aisles. Pick up pieces of wire, twine, string, etc., which could become entangled in brush or brush plugs.

Avoid turning the steering wheel too sharply when the machine is in motion. The machine is very responsive to the movement of the steering wheel. Avoid sudden turns, except in emergencies. Overlap brush paths.

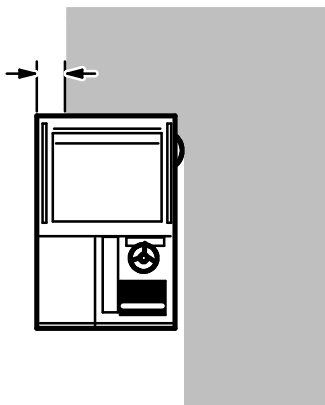

OVERLAPPING PATHS

04622

Sweep as straight a path as possible. Avoid bumping into posts or scraping the sides of the sweeper.

Stop the vacuum fan when sweeping in wet conditions to avoid soaking the hopper dust filters.

1. Multi-Level Dump Machine: Press and hold the hopper door switch in the (Hopper Door Open) position to open the hopper door and until the hopper door lamp goes out.

NOTE: The hopper door has to be open to sweep. The hopper door lamp lights if the hopper door is not fully open. The lamp will go out when the hopper door is fully open.

2. Place the main brush switch in the (Main Brush #1) or the (Main Brush #2) position depending on the debris to be picked up.
3. Move the main brush position lever back and to the right into the (Main Brush Down) position.
4. Place the side brush switch in the (Side Brush On) position to lower and start the side brush.
5. Place the filter shaker and vacuum fan switch in the (Vacuum Fan) position to start the vacuum.
6. Sweep as required.

TO DUMP LOW DUMP HOPPER

1. Pull the main brush position lever all the way back and to the left into the (Main Brush Up) position.
2. Place the main brush switch in the (Main Brush Off) position to turn off the main brush.
3. Place the side brush switch in the (Side Brush Off) position to raise and stop the side brush.
4. Press the filter shaker and vacuum fan switch in the (Filter Shaker) position to shake the dust filters.
5. Slowly drive the machine to the dump site or dumpster.
6. Press and hold the hopper switch in the (Hopper Up) position to raise the hopper.
7. Release the hopper switch in the (Hopper Hold) position to stop and hold the hopper at that height.



WARNING: Falling Hopper. Engage Hopper Support Bar Before Working Under Hopper.

8. Slowly back the machine away from the dump site or dumpster.
9. Press and hold the hopper switch in the (Hopper Down) position to lower the hopper.
10. Place the main brush switch in the (Main Brush #1) or the (Main Brush #2) position depending on the debris to be picked up.
11. Move the main brush position lever back and to the right into the (Main Brush Down) position.
12. Place the side brush switch in the (Side Brush On) position to lower and start the side brush.
13. Place the filter shaker and vacuum fan switch in the (Vacuum Fan) position to start the vacuum.
14. Continue sweeping.

OPERATION

TO DUMP MULTI-LEVEL DUMP HOPPER

1. Pull the main brush position lever all the way back and to the left into the (Main Brush Up) position.
2. Place the main brush switch in the (Main Brush Off) position to turn off the main brush.
3. Place the side brush switch in the (Side Brush Off) position to raise and stop the side brush.
4. Press and hold the hopper door switch in the (Hopper Door Close) position to close the hopper door and until the hopper door lamp lights.
5. Press the filter shaker and vacuum fan switch in the (Filter Shaker) position to shake the dust filters.
6. Slowly drive the machine up to the dump site or dumpster.
7. Press and hold the hopper switch in the (Hopper Up) position to raise the hopper.

FOR SAFETY: When Using Machine, Make Sure Adequate Clearance Is Available Before Raising Hopper.

8. Release the hopper switch in the (Hopper Hold) position to stop and hold the hopper at that height.
9. Drive the machine forward until the hopper is over the dumpster or dump site.

FOR SAFETY: When Using Machine, Move Machine With Care When Hopper Is Raised.

NOTE: Lowering the hopper into the dumpster may help to control flying dust.

10. Press and hold the hopper door switch in the (Hopper Door Open) position to open the hopper door and until the hopper door lamp goes out.



WARNING: Falling Hopper. Engage Hopper Support Bar Before Working Under Hopper.

11. When the hopper is empty, press and hold the hopper door switch in the (Hopper Door Close) position to close the hopper door and until the hopper door lamp lights.
12. Slowly back the machine away from the dump site or dumpster.
13. Press and hold the hopper switch in the (Hopper Down) position to lower the hopper.
14. Press and hold the hopper door switch in the (Hopper Door Open) position to open the hopper door and until the hopper door lamp goes out.

NOTE: The hopper door has to be open to sweep. The hopper door lamp lights if the hopper door is not fully open. The lamp will go out when the hopper door is fully open.

15. Place the main brush switch in the (Main Brush #1) or the (Main Brush #2) position depending on the debris to be picked up.
16. Move the main brush position lever back and to the right into the (Main Brush Down) position
17. Place the side brush switch in the (Side Brush On) position to lower and start the side brush.
18. Place the filter shaker and vacuum fan switch in the (Vacuum Fan) position to start the vacuum.
19. Continue sweeping.

POST OPERATION CHECKLIST – ENGINE OPERATING

Check brush patterns for width and evenness.

TO STOP MACHINE

1. Return the directional pedal to the “neutral” position. Apply the brake.
2. Pull the main brush position lever all the way back and to the left into the (Main Brush Up) position.
3. Place the main brush switch in the (Main Brush Off) position to turn off the main brush.
4. Place the side brush switch in the (Side Brush Off) position to raise and stop the side brush.
5. Place the filter shaker and vacuum fan switch in the middle position to turn off the vacuum.
6. Turn the operating and/or hazard lights off if used.
7. Set the machine parking brake.
8. Move the throttle lever to the (Slow) position and push the lever all the way forward until the engine stops.
9. Turn the ignition switch key to the left. Remove the key from the key-operated ignition switch.

FOR SAFETY: Before Leaving Or Servicing Machine; Stop On Level Surface, Set Parking Brake, And Turn Off Machine And Remove Key.

POST OPERATION CHECKLIST – ENGINE STOPPED

- Check skirts for damage, wear, and adjustment.
- Check for wire or string tangled on brushes.
- Check for leaks.

TO ENGAGE LOW DUMP MODEL HOPPER SUPPORT BAR

1. Set the machine parking brake and start the engine.

FOR SAFETY: Before Leaving Or Servicing Machine; Stop On Level Surface And Set Parking Brake.

2. Move the throttle lever to (Fast).
3. Raise the hopper to the fully raised position.
4. Remove the hopper support bar from its storage clip.

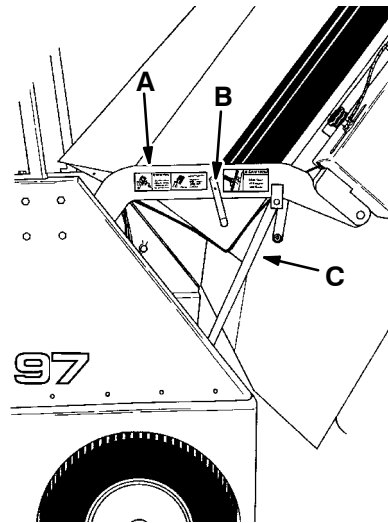

ENGAGED HOPPER SUPPORT BAR

- A. Lift Arm**
- B. Storage Clip**
- C. Support Bar**

06718

OPERATION

5. Position the end of the support bar on the support bar stop on the machine frame.

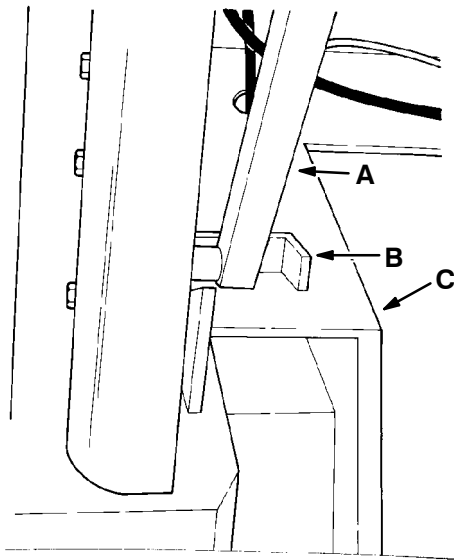

SUPPORT BAR STOP

01437

- A. Support Bar Hopper**
- B. Bar Stop**
- C. Machine Frame**

6. Slowly lower the hopper so the support bar rests securely against the support bar stop.
7. Stop the engine.
8. Check the support bar to make sure it is securely engaged.

TO DISENGAGE LOW DUMP MODEL HOPPER SUPPORT BAR

1. Start the engine.
2. Move the throttle lever to (Fast).
3. Raise the hopper to the fully raised position.
4. Raise the support bar into its storage position. Make sure the storage clip is holding the support bar in place.
5. Lower the hopper.
6. Stop the engine.

TO ENGAGE MULTI-LEVEL DUMP MODEL HOPPER SUPPORT BAR

1. Set the machine parking brake and start the engine.

FOR SAFETY: Before Leaving Or Servicing Machine; Stop On Level Surface And Set Parking Brake.

2. Move the throttle lever to (Fast).
3. Raise the hopper to the fully raised position.
4. Position the hopper support bar under the hopper lift arm cam.

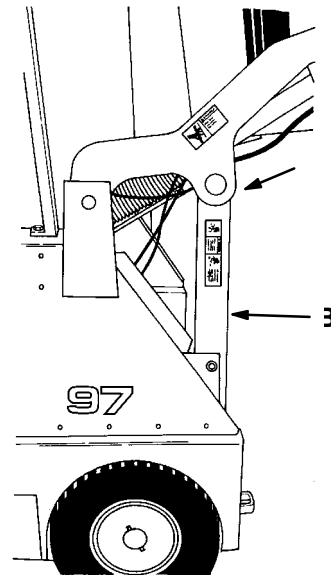

ENGAGED HOPPER BAR

06719

- A. Lift Arm**
- B. Hopper Support Bar**

5. Slowly lower the hopper so the lift arm cam seats itself on top of the hopper support bar.
6. Stop the engine.
7. Check the hopper support bar to make sure it is securely engaged.

**TO DISENGAGE MULTI-LEVEL DUMP MODEL
HOPPER SUPPORT BAR**

1. Start the engine.
2. Move the throttle lever to (Fast).
3. Raise the hopper to the fully raised position.
4. Lower the hopper support bar to its storage location.

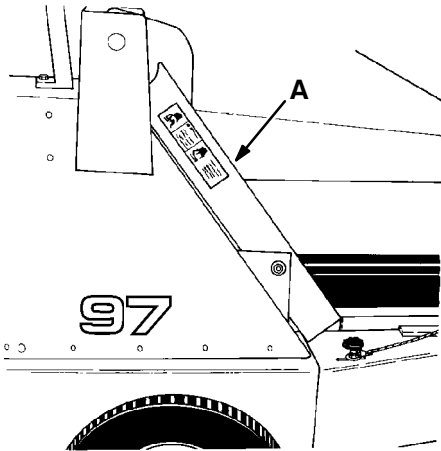

06739

DISENGAGED HOPPER SUPPORT BAR**A. Hopper Support Bar**

5. Lower the hopper.
6. Stop the engine.

OPERATION ON GRADES

Drive the machine slowly on grades. Use the service brakes to control machine speed.

**FOR SAFETY: When Using Machine, Go Slow On
Grades And Slippery Surfaces.**

The maximum rated ramp climb and descent angle is 15° with an empty hopper, and 13° with a full hopper.

OPTION OPERATION

VACUUM WAND OPTION

The vacuum wand option gives the machine the added flexibility of picking up debris not accessible by the machine. A 120 in (3050 mm) hose utilizes the machine vacuum system.

TO OPERATE VACUUM WAND

1. Stop the machine close to the area to be cleaned.
2. Raise the main brush and side brush.
3. Stop the engine and set the machine parking brake.

FOR SAFETY: Before Leaving Or Servicing Machine; Stop On Level Surface, Set Parking Brake, And Turn Off Machine.

4. Open the hopper access door.
5. Release the vacuum wand door from its retaining clip and rotate the door back into place.

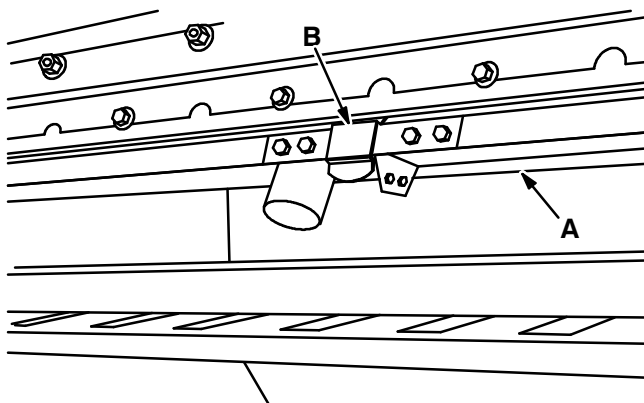

VACUUM WAND DOOR

- A. Vacuum Wand Door**
- B. Retaining Clip**

6. Push the loose end of the wand hose onto the vacuum wand.

7. Push the wand hose onto the hose connection on the vacuum wand door.

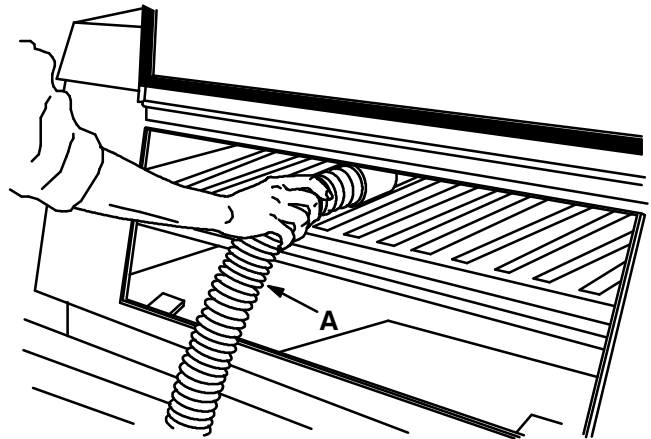

CONNECTING WAND HOSE

06741

A. Wand Hose

8. Start the engine.
9. Move the throttle lever to the (Fast) position.
12. Place the filter shaker and vacuum fan switch in the (Vacuum Fan) position to start the vacuum fan.
13. Vacuum the area as required.
14. When finished, place the filter shaker and vacuum fan switch in the middle position to stop the vacuum fan.
10. Stop the engine.
11. Pull the wand hose off the hose connection on the vacuum wand door.
12. Disconnect the wand hose from the vacuum wand.

13. Rotate the vacuum wand door forward until it catches in the retaining clip.
14. Close the hopper access door.
15. Return the vacuum wand and wand hose to their storage clips.

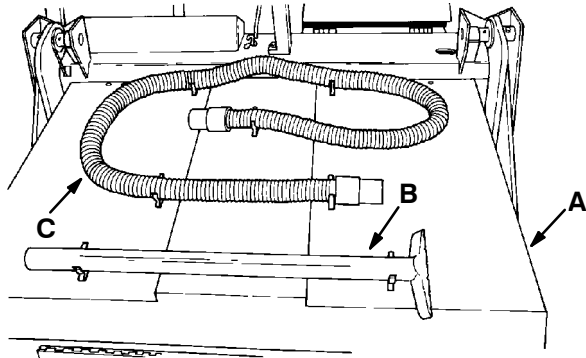

01445

VACUUM WAND STORAGE LOCATIONS

- A. Hopper Cover**
- B. Vacuum Wand**
- C. Wand Hose**

HOPPER DOLLY OPTION

The hopper dolly option makes the job of removing the debris hopper easy. The machine must be equipped with the snow blade hydraulic kit to allow the hydraulic connections to be disconnected in a timely manner.

TO REMOVE HOPPER WITH DOLLY

1. Set the parking brake. Start the engine and raise the hopper.

FOR SAFETY: Before Leaving Or Servicing Machine; Stop On Level Surface And Set Parking Brake.

2. Engage the hopper support bar. Lower the hopper onto the support bar. Stop the engine.



WARNING: Falling Hopper. Engage Hopper Support Bar Before Working Under Hopper.

3. Check the hopper support bar to make sure it is securely engaged.

4. Disconnect and plug all hoses and disconnect all wires between the hopper and the machine.
5. Start the engine, raise the hopper, place the hopper support bar in its storage location, and lower the hopper one-half of the way down.
6. Hook the hopper dolly on the hopper hook and lower the hopper. Stop the engine.

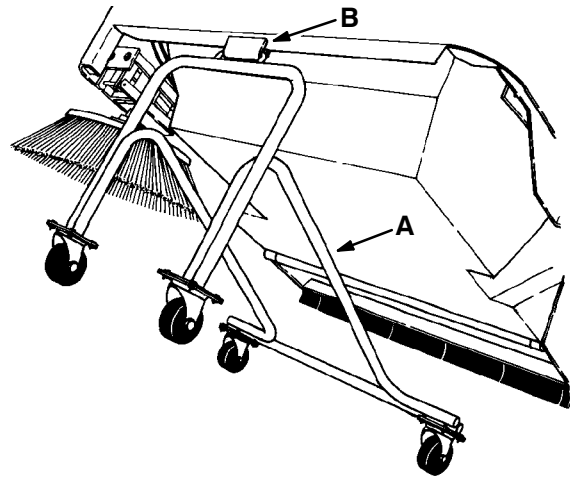

01446

HOPPER DOLLY HOOKED ON HOPPER

- A. Hopper Dolly**
- B. Hopper Hook**

7. Remove the two hopper lift arm release pins.

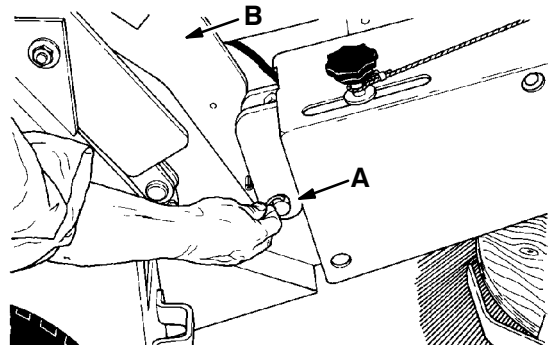

01447

LIFT ARM RELEASE PINS

- A. Release Pin**
- B. Lift Arm**

8. Push the lift arms down to release the hopper from the lift arms.
9. Roll the hopper and dolly away from the machine.

OPERATION

TO REINSTALL HOPPER WITH DOLLY

1. Position the hopper and dolly in the machine.
2. Raise the lift arms slightly to hook the lift arms onto the hopper brackets.
3. Install the two hopper lift arm release pins.
4. Raise the hopper, remove the hopper dolly, engage the hopper support bar, and lower the hopper onto the support bar.
5. Reconnect the hoses and wires between the hopper and the machine.
6. Raise the hopper, place the hopper support bar in its storage location, and lower the hopper.

HEATER/DEFROSTER OPTION

The heater/defroster option includes a fan powered heater and a defroster fan. A switch on the defroster fan base controls the defroster fan.

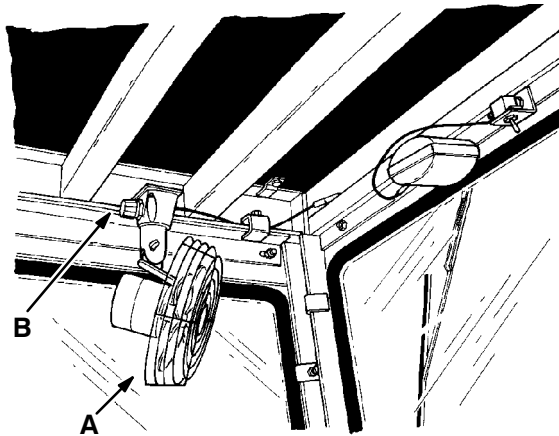

DEFROSTER FAN

- A. Fan
- B. Switch

01448

A switch on the front of the seat support controls the heater fan. A valve on the engine controls the hot coolant flow to the heater core. Turning the valve handle to the right closes the valve and stops the hot coolant flow. Turning the valve handle to the left opens the valve and allows hot coolant to flow to the heater core.

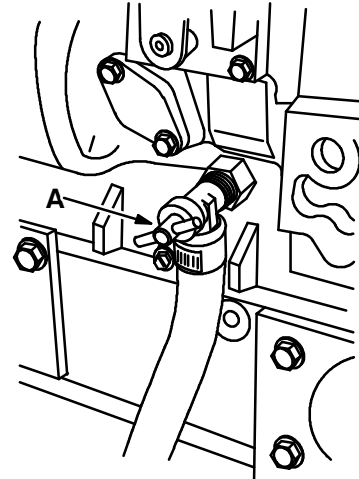

HEATER VALVE

06742

A. Valve

The air deflectors on the sides of the heater are repositionable to allow the air flow to be directed as desired.

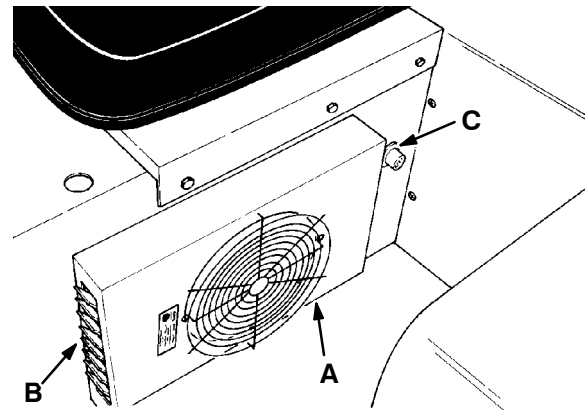

HEATER

- A. Heater
- B. Air Deflector
- C. Heater Fan Switch

01450

SNOW BLADE OPTION

The snow blade option gives the machine the added flexibility to remove snow from walks and driveways.

TO INSTALL SNOW BLADE

1. Set the parking brake; start the engine, and raise the hopper.

FOR SAFETY: Before Leaving Or Servicing Machine; Stop On Level Surface And Set Parking Brake.

2. Engage the hopper support bar. Lower the hopper onto the support bar. Stop the engine.

! WARNING: Falling Hopper. Engage Hopper Support Bar Before Working Under Hopper.

3. Check the hopper support bar to make sure it is securely engaged.
4. Disconnect the hydraulic quick-disconnect fittings, large vacuum hose, and the wire connections. Label and remove the two small vacuum hoses going to the pressure switch.
5. Start the engine, raise the hopper, place the hopper support bar in its storage location, and lower the hopper one half of the way down.
6. Hook the hopper dolly on the hopper hook and lower the hopper. Stop the engine.

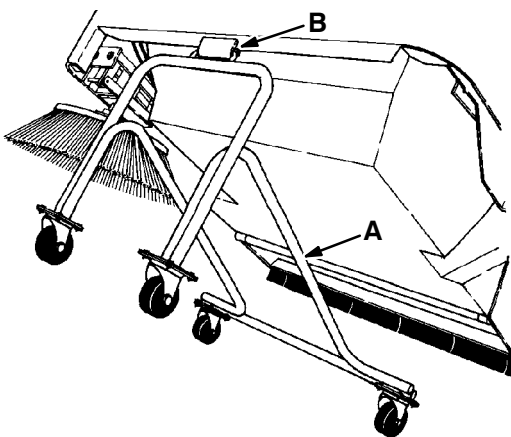

01446

HOPPER DOLLY HOOKED ON HOPPER

- A. Hopper Dolly
- B. Hopper Hook

7. Remove the two hopper lift arm release pins.

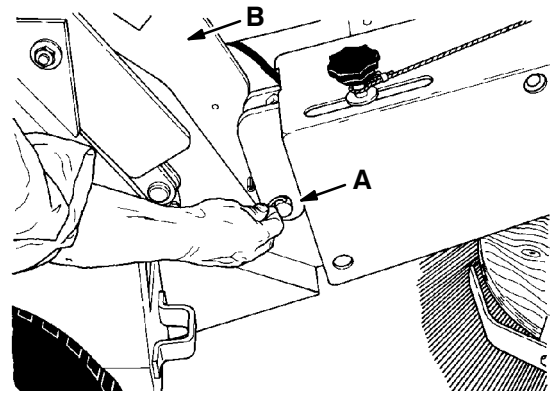

01447

LIFT ARM RELEASE PINS

- A. Release Pin
- B. Lift Arm

8. Push the lift arms down to release the hopper from the lift arms.
9. Roll the hopper and dolly away from the machine.
10. Position the snow blade assembly so the upper cross bar pins engage the lift arm hooks.
11. Install clevis pins through the cross bar and the lift arms.

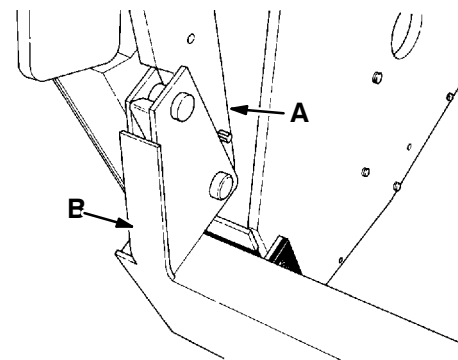

01451

LIFT ARM AND CROSS BAR

- A. Lift Arm
- B. Cross Bar

12. Loop the snow blade limiting chain over the lift arm tube and close the loop with the connecting link.

NOTE: Do not lift the snow blade without the limiting chain installed.

13. Install tire chains on the rear tire.
14. Position the stabilizer leg stop arm over the spring loaded stop lever to keep the leg raised

OPERATION

on the multi-level dump model.

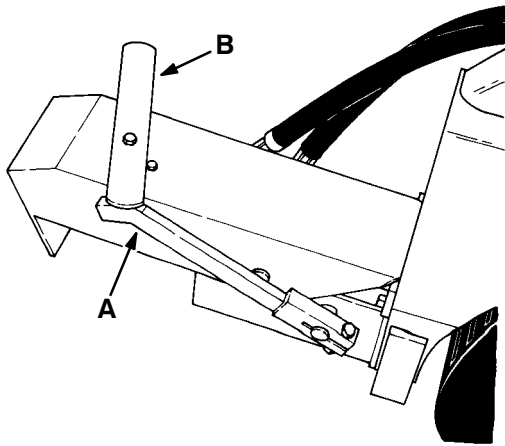

01453

STABILIZER LEG STOP ARM

- A. Stop Lever
- B. Stop Arm

15. Remove the sector pin from the A-frame, adjust the snow blade to the desired angle and replace the clevis pin.

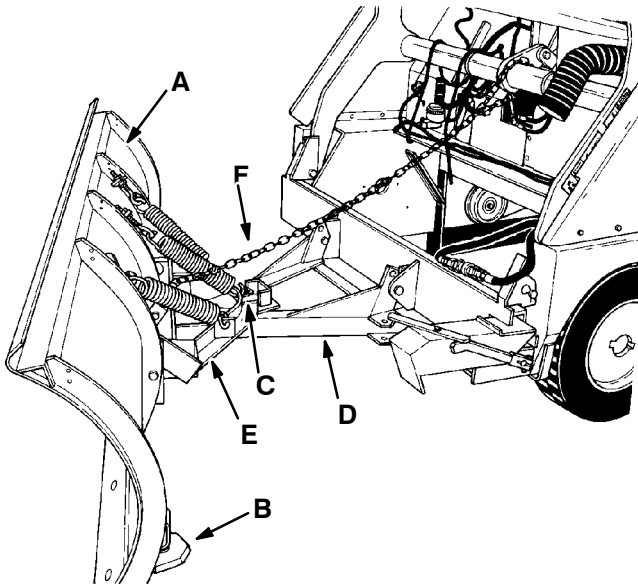

01454

SNOW BLADE INSTALLATION

- A. Snow Blade
- B. Runner Spindle
- C. Sector Pin
- D. A-Frame
- E. Quadrant
- F. Limiting Chain

TO OPERATE SNOW BLADE

Operate the machine as normally done using the hopper switch to raise and lower the snow blade.

Begin plowing early when snow reaches 1 to 4 in (25 to 100 mm). Do not allow snow to accumulate. Heavy, wet snow can create hazards at even a 1 in (25 mm) accumulation. In heavier amounts, snow can be extremely difficult to handle. Do not allow snow to become packed and frozen. Crusted snow can hinder traction in future plowing. Choose the proper plowing speed. The heavier the snow, the slower the speed.

The plow blade should be set at the best angle for rolling the snow sideways and in the desired direction. Snow of any considerable depth cannot be pushed straight ahead for more than a short distance.

For best operation, the bottom edge of the snow blade should be slightly above the ground. If adjustments are needed, they can be made by adding flat washers to the runner spindles. Place additional washers under the runner bracket to raise the blade. Remove washers to lower the blade.

To change the angle of the blade, raise the blade as far as the limiting chain will permit. Pull out the sector pin and the blade can be moved to the desired position. Then replace the sector pin. The sector pin is designed to be a shear pin. If the plow strikes a solid, immovable object, the pin will shear, allowing the blade to swing away from the object before the equipment is damaged. The blade assembly is mounted on the hydraulic lift arms of the machine which are free to float upward if necessary.

Under some conditions, snow can be pushed to unused areas and stacked to a considerable height. To do this, place the blade in a straight-on position. Push the snow forward by raising the plow as you move into the pile.

Stack snow only with the blade in a straight-on position. Do not create a vertical wall, but slope the piles so that later snow may be pushed up the slope.

Clearing large open areas can be done best by using a combination of snow removal equipment, such as a snow blade and snow blower or loader of some type. The snow can be plowed into windrows or piles and then blown into or loaded onto trucks and carried away. However, if only a blade is available, the area can be cleared by using the proper technique and common sense.

As a guide to help determine how much snow the plow can handle, remember that with a 6 in (152 mm) snowfall, the plow can easily move that amount of snow in two passes. With more snow, it will handle less; with less snow, more.

A suggested method of plowing is as follows:

Make the first pass one blade width in from the outside edge.

Make the second pass around the outside edge, moving the snow to the edge of the area, then keep moving in. Double the blade width from edge of the snow covered area and move this amount to the outside edge.

TO REMOVE SNOW BLADE

1. Stop the engine and set the parking brake.

FOR SAFETY: Before Leaving Or Servicing Machine; Stop On Level Surface, Set Parking Brake, And Turn Off Machine.

2. Position the stabilizer leg stop arm so the stabilizer leg is free to lower on the multi-level dump model.
3. Remove the tire chains.
4. Remove the limiting chain from the lift arm tube.
5. Remove the cross bar clevis pins and disconnect the cross bar from the lift arms.
6. Start the engine, then release the parking brake.
7. Back the machine away from the snow blade, then set the parking brake.

8. Position the hopper and dolly in the machine.
9. Raise the lift arms slightly to hook the lift arms onto the hopper brackets.
10. Install the two hopper lift arm release pins.
11. Raise the hopper, remove the hopper dolly, engage the hopper support bar, and lower the hopper onto the support bar.
12. Reconnect the hoses and wires between the hopper and the machine.
13. Raise the hopper, place the hopper support bar in its storage location, and lower the hopper.

OPERATION

MACHINE TROUBLESHOOTING

Problem	Cause	Remedy
Excessive dusting	Dust skirts and seals worn, damaged, not adjusted properly	Replace or adjust skirts or seals
	Dust filter clogged	Shake and/or clean or replace filter
	Vacuum wand door closed	Open vacuum wand door
	Vacuum hose damaged	Replace vacuum hose
	Vacuum fan failure	See <i>HYDRAULIC SYSTEM TROUBLESHOOTING</i> : Main brush turns in I and II speed, but no vacuum fan
Poor sweeping performance	Brush bristles worn	Replace brushes
	Brushes not adjusted properly	Adjust brushes
	Debris caught in brush drive mechanism	Free mechanism of debris
	Main brush drive failure	See <i>HYDRAULIC SYSTEM TROUBLESHOOTING</i> : Main brush turns slowly or not at all
	Side brush drive failure	See <i>HYDRAULIC SYSTEM TROUBLESHOOTING</i> : Side brush turns slowly or not at all
	Hopper not adjusted properly	Adjust hopper floor clearance
	Hopper full	Empty hopper
	Hopper floor skirts worn, damaged	Replace skirts

NOTE: For more specific electro-hydraulic system troubleshooting information, see HYDRAULIC SYSTEM TROUBLESHOOTING in the MAINTENANCE section.

TRANSPORTING MACHINE

PUSHING OR TOWING MACHINE

The machine may be pushed from the front or the rear, using the bumpers provided, only after placing the rear wheel on a dolly.

The machine may be towed only from the rear. Do not pull on the front bumper.

MACHINE JACKING INSTRUCTIONS

1. Stop the engine and set the machine parking brake.

FOR SAFETY: Before Leaving Or Servicing Machine; Stop On Level Surface, Set Parking Brake, And Turn Off Machine And Remove Key.

2. Empty the debris hopper before attempting to jack the machine up.
3. Block the tires which are not being jacked up to secure the machine's position.

FOR SAFETY: When Servicing Machine, Block Machine Tires Before Jacking Machine Up.

4. Use a scissors or hydraulic-type jack of adequate capacity to raise the machine. Jack up the machine only at the designated locations.

FOR SAFETY: When Servicing Machine, Use Hoist Or Jack Of Adequate Capacity To Lift Machine.

FOR SAFETY: When Servicing Machine, Jack Machine Up At Designated Locations Only. Block Machine Up With Jack Stands.

The front jacking locations are the bottom edge of the machine frame next to the front machine tires.

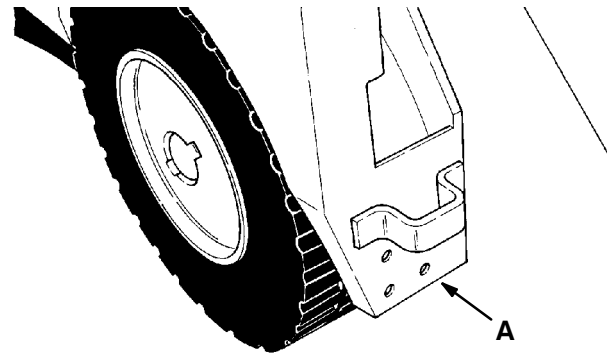

**FRONT JACKING LOCATION
(RIGHT SIDE SHOWN)**

01455

A. Jacking Location

The rear jacking location is the bottom of the rear edge of the machine frame.

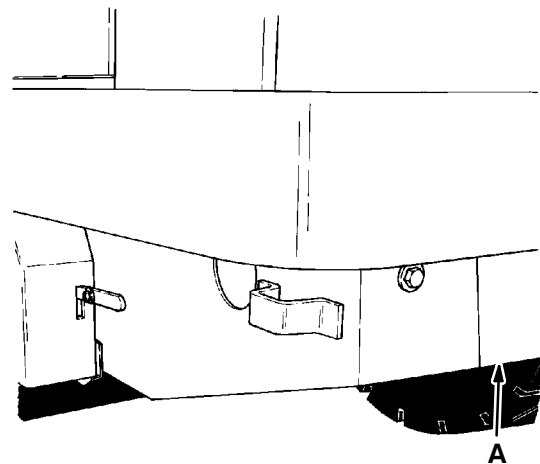

REAR JACKING LOCATION

01456

A. Jacking Location

OPERATION

- Block machine up with jack stands or similar devices to make sure machine is secure.

FOR SAFETY: When Servicing Machine, Jack Machine Up At Designated Locations Only. Block Machine Up With Jack Stands.

- Lower the machine onto the jack stands.
- Check to make sure the machine is secure.
- Service the machine as required.
- When finished servicing the machine, raise the machine up off the jack stands.
- Remove the jack stands from under the machine.
- Lower the machine.
- Remove the blocks from the tires.

MACHINE TIE-DOWN INSTRUCTIONS

The machine may be tied down at each of the four corners of the machine at the locations specified.

To tie the machine down, use the tie down lug provided.

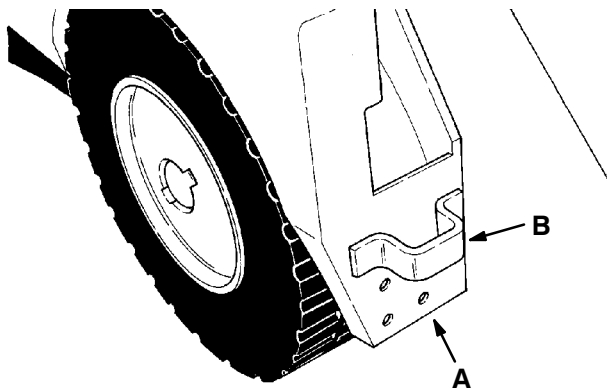

**FRONT TIE-DOWN LUG
(RIGHT SIDE SHOWN)**

01455

- A. Machine Frame
- B. Tie-Down Lug

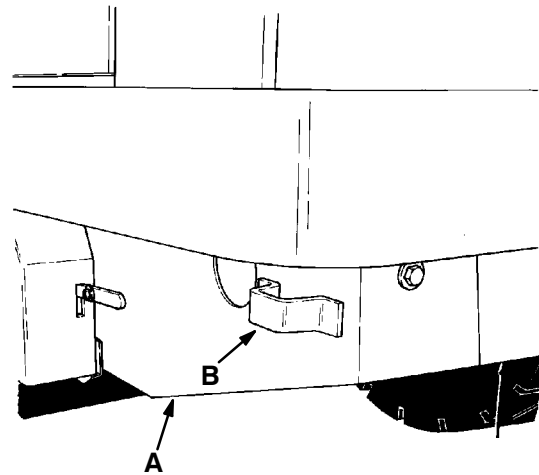

**REAR TIE-DOWN LUG
(LEFT SIDE SHOWN)**

01456

- A. Machine Frame
- B. Tie-Down Lug

When transporting the machine on a trailer or in a truck, be sure to set the machine parking brake and block the machine tires to prevent the machine from rolling.

MACHINE STORAGE

STORING MACHINE

When storing the machine for extended periods of time, the following procedures must be followed to lessen the chance of rust, sludge, and other undesirable deposits from forming.

1. Empty the debris hopper.
2. Change engine oil.
3. Raise the main and side brushes.
4. Park the machine in a cool and dry area.
5. Stop the engine.
6. Fill the hydraulic reservoir with hydraulic fluid to the full mark on the dipstick to prevent excessive condensation from forming in the reservoir.
7. Drain the coolant from the radiator and engine block.
8. Close the engine cooling system drain cocks.

SECTION 3

CONTENTS

	Page		Page
RECOMMENDED FIRST 50-HOUR		ENGINE	3-20
MACHINE INSPECTION	3-3	LUBRICATION	3-20
MAINTENANCE CHART	3-4	COOLING SYSTEM	3-20
LUBRICATION	3-6	AIR INTAKE SYSTEM	3-21
ENGINE	3-6	AIR FILTER SERVICE INDICATOR	3-21
REAR WHEEL SUPPORT PIVOT	3-6	AIR FILTER	3-21
STEERING GEAR	3-6	TO REPLACE AIR FILTER ELEMENT ...	3-22
HOPPER COVER LATCH	3-6	FUEL SYSTEM	3-23
SIDE BRUSH PIVOT PINS	3-7	FUEL WATER TRAP FILTER	3-23
STABILIZER LEG PIVOT PIN	3-7	TO REPLACE THE FUEL FILTER	
FRONT WHEEL BEARINGS	3-7	ELEMENT	3-23
HYDRAULICS	3-8	FUEL INJECTION PUMP	3-24
HYDRAULIC FLUID	3-8	FUEL INJECTORS	3-24
HYDRAULIC FLUID RESERVOIR	3-8	PRIMING THE FUEL SYSTEM	3-24
TO DRAIN THE HYDRAULIC FLUID		TO PRIME FUEL SYSTEM	3-25
RESERVOIR	3-9	DIESEL FUEL TROUBLESHOOTING	3-26
TO FILL THE HYDRAULIC FLUID		CYLINDER HEAD	3-27
RESERVOIR	3-9	CYLINDER HEAD	3-27
HYDRAULIC FLUID RESERVOIR BREATHER ..		VALVE CLEARANCE	3-27
3-10		ELECTRICAL SYSTEM	3-28
HYDRAULIC FLUID FILTER	3-10	BATTERY	
TO REPLACE THE HYDRAULIC		3-28	
FLUID FILTER ELEMENT	3-10	ELECTRICAL SCHEMATIC	3-29
HYDRAULIC PUMPS	3-11	BELTS AND CHAINS	3-32
TO START AND BREAK-IN		ENGINE FAN BELT	3-32
HYDRAULIC PUMP	3-11	STATIC DRAG CHAIN	3-32
DIRECTIONAL CONTROL PEDAL		DEBRIS HOPPER	3-33
"NEUTRAL" POSITION ADJUSTMENT ..	3-11	HOPPER DUST FILTERS	3-33
SPEED LIMITER	3-13	TO REMOVE HOPPER DUST	
HYDRAULIC FLUID LEAKS	3-13	FILTER PANELS	3-33
HYDRAULIC SCHEMATIC –		TO INSTALL HOPPER DUST FILTERS ..	3-34
LOW DUMP MODEL	3-14	THERMO-SENTRY™	3-34
HYDRAULIC SCHEMATIC –		DEBRIS HOPPER	3-34
MULTI-LEVEL DUMP	3-15	TO ADJUST HOPPER	3-34
HYDRAULIC SYSTEM TROUBLESHOOTING	3-16	STABILIZER LEG	3-38
HYDRAULIC COMPONENTS		TO ADJUST STABILIZER LEG	3-38
TROUBLESHOOTING	3-19	BRUSHES	3-39
		MAIN BRUSH	3-39
		TO REMOVE MAIN BRUSH	3-39
		TO INSTALL MAIN BRUSH	3-39
		TO CHECK AND ADJUST MAIN	
		BRUSH PATTERN	3-40
		SIDE BRUSH	
		3-41	
		TO REMOVE SIDE BRUSH	3-41
		TO INSTALL SIDE BRUSH	3-41
		TO ADJUST SIDE BRUSH MAXIMUM	
		RAISED HEIGHT	3-42
		TO ADJUST SIDE BRUSH HEIGHT	
		ANGLE	3-42
		TO ADJUST SIDE BRUSH BUMPER	
		CLEARANCE	3-43

MAINTENANCE

	Page
SKIRTS AND SEALS	3-44
HOPPER LIP SKIRTS	3-44
TO REPLACE HOPPER LIP	3-44
HOPPER SIDE SEALS	3-44
TO REPLACE HOPPER SIDE SEALS . . .	3-44
BRUSH DOOR SKIRTS	3-45
TO REPLACE AND ADJUST BRUSH	
DOOR SKIRTS	3-45
REAR SKIRTS	3-46
TO REPLACE AND ADJUST	
REAR SKIRTS	3-46
HOPPER DUST DUMP DOOR SEAL	3-46
TO REPLACE DUST DUMP DOOR SEAL	3-46
TO CHECK AND ADJUST HOPPER	
DUST DUMP DOOR SEAL	3-47
TOP HOPPER SEAL – LOW DUMP MODEL	3-47
TO REPLACE TOP HOPPER SEAL	3-47
HINGED TOP HOPPER SEAL –	
MULTI-LEVEL DUMP MODEL	3-48
TO REPLACE AND ADJUST HINGED	
TOP HOPPER SEAL	3-48
HOPPER DOOR HINGE SEAL –	
MULTI-LEVEL DUMP MODEL	3-49
TO REPLACE HOPPER DOOR	
HINGE SEAL	3-49
LATCHES	3-50
HOPPER COVER LATCH	3-50
TO ADJUST HOPPER COVER LATCH . .	3-50
SIDE DOOR LATCHES	3-50
HOPPER INSPECTION DOOR LATCH	3-51
REAR ACCESS DOOR LATCH	3-51
BRAKES AND TIRES	3-52
SERVICE BRAKES	3-52
PARKING BRAKES	3-53
TIRES	3-53
OPTIONS	
3-54	
AIR FILTER OPTION	3-54
TO REPLACE AIR FILTER ELEMENT . . .	3-54
SEVERE ENVIRONMENT AIR	
FILTER OPTION	3-55
TO REPLACE AIR FILTER ELEMENT . . .	3-55
OPERATING LIGHTS OPTION	3-56
HEADLIGHT	3-56
SIDE BRUSH SPOTLIGHT	3-56
DUMPSTER SPOTLIGHT	3-57
DEBRIS DEFLECTOR SKIRTS OPTION . . .	3-57
SIDE BRUSH DUST CONTROL OPTION . .	3-57

RECOMMENDED FIRST 50-HOUR MACHINE INSPECTION

After the first 50 hours of operation, the following procedures are recommended:

1. Check the brush pattern for correct brush adjustment.
2. Change the hydraulic fluid filter.
3. Change the engine oil after the first 35 hours of operation.
4. Check the torque of the engine cylinder head cap screws.
5. Perform all 50-hour interval lubrication and maintenance procedures listed in the *MAINTENANCE CHART*.

MAINTENANCE CHART

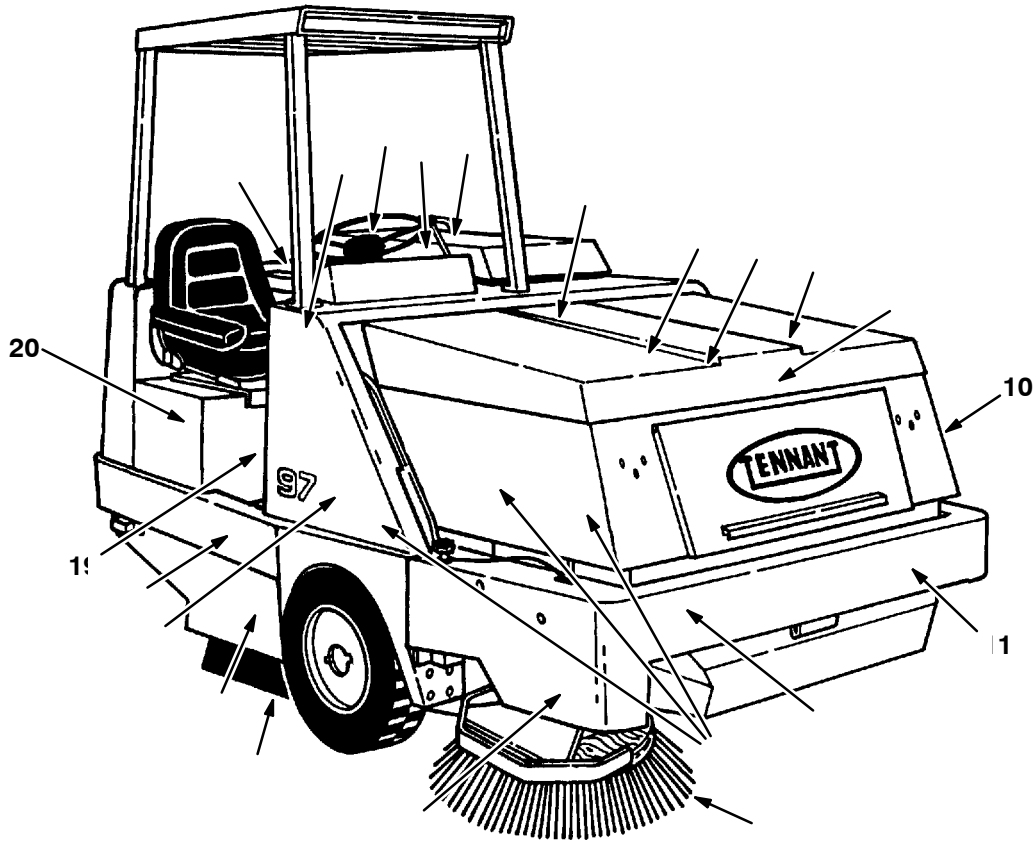

06461

Interval	Key	Description	Procedure	Material/ Lubricant	No. of Service Points
Daily	2	Air filter restriction indicator	Check the restriction indicator	—	1
	5	Engine	Check oil level	EO	1
	3	Radiator	Check coolant level	WG	1
			Clean screen	—	1
	12	Brush and hopper lip skirts	Check for damage wear, and adjustment	—	9(11)
	15	Side brush	Check for damage, wear, and adjustment	—	1
	16	Main brush	Check for damage, wear, and adjustment	—	1
	20	Fuel water trap	Drain water	—	1
50 Hours	4	Engine fan belt	Check tension	—	1
	10	Hopper	Check floor clearance	—	1
	16	Main brush	Rotate end-for-end and check adjustment	—	1
	18	Rear tire, low dump model	Check tire pressure	—	1
	21	Hydraulic fluid cooler	Clean cooling fins	—	1

MAINTENANCE

Interval	Key	Description	Procedure	Material/ Lubricant	No. of Service Points
100 Hours	1	Parking brake	Check adjustment	–	1
	7	Hydraulic fluid reservoir	Check fluid level	HYDO	1
	8	Hopper dust filter	Inspect, clean, or replace	–	2
	13	Dust seals	Check for damage or wear	–	5(6)
	5	Engine crankcase	Change oil and filter	EO	1
200 Hours	5	Engine	Steam clean exterior	–	1
	9	Hopper cover latch	Lubricate	DL	1
	11	Stabilizer leg pivot pin	Lubricate	SPL	1
	14	Side brush pivot pins	Lubricate	SPL	5
	19	Rear wheel support pivot	Lubricate	SPL	1
400 Hours	20	Fuel filter	Replace	–	2
	20	Fuel water trap	Clean	–	1
	7	Hydraulic fluid reservoir	Change hydraulic fluid	HYDO	1
	6	Hydraulic fluid filter	Change filter element	–	1
	17	Brake master cylinder	Check fluid level	BF	1
800 Hours	7	Hydraulic reservoir breather	Replace	–	1
	7	Hydraulic reservoir strainer	Replace	–	1
	3	Cooling system	Flush	WG	1
2000 Hours	23	Front wheel bearings	Repack	SPL	2

BF – Brake fluid

EO – Engine oil

HYDO – TENNANT or approved hydraulic fluid

SPL – Special lubricant, Lubriplate EMB grease (TENNANT part no. 01433–1)

WG – Water and permanent-type ethylene glycol anti-freeze, one-to-one ratio

DL – Dry lubricant

NOTE: More frequent intervals may be required in extremely dusty conditions.

LUBRICATION

ENGINE

Check the engine oil level daily.

Diesel powered engines should be lubricated with SAE–CC/CD rated engine oil. Change the engine oil and oil filter after every 100 hours of operation.

The following oil grades are recommended for engines operating in the ambient temperatures listed.

SINGLE AND MULTI-VISCOSITY OILS		
Below 32°F (Below 0°C)	32° to 77° F (0° to 25° C)	Above 77° F (Above 25° C)
10W	20	30
10W 30		

The engine oil capacity is 8.38 qt (9 L) including the oil filter.

REAR WHEEL SUPPORT PIVOT

There is a grease fitting which is used to lubricate the rear wheel support pivot bearing.

Access to the grease fitting is through the left rear access door. Apply Lubriplate EMB grease (TENNANT part no. 01433–1) grease after every 200 hours of operation.

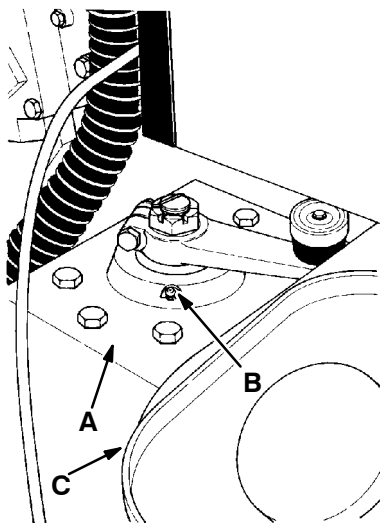

REAR WHEEL SUPPORT PIVOT

- A. Wheel Support
- B. Grease Fitting
- C. Fuel Tank

STEERING GEAR

The steering gear has been lubricated at the factory and should not require any additional lubricant unless a massive leak occurs.

A square head plug located on the left side of the steering gearbox is provided to fill the steering gear with grease if necessary.

The proper lubricant is grade 1 calcium soap base EP grease.

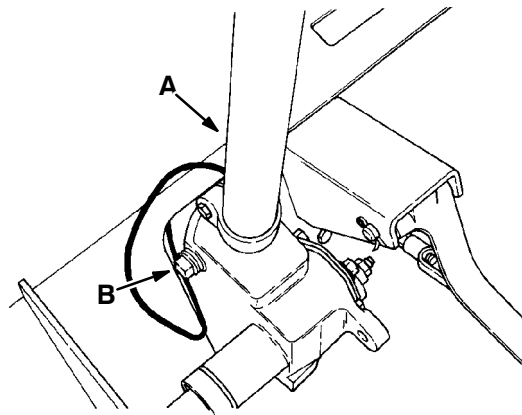

01457

STEERING GEAR LUBRICATION PLUG

- A. Steering Gearbox
- B. Fill Plug

HOPPER COVER LATCH

The hopper cover latch is located under the hopper cover. Lubricate the latch with a dry lubricant after every 200 hours of operation.

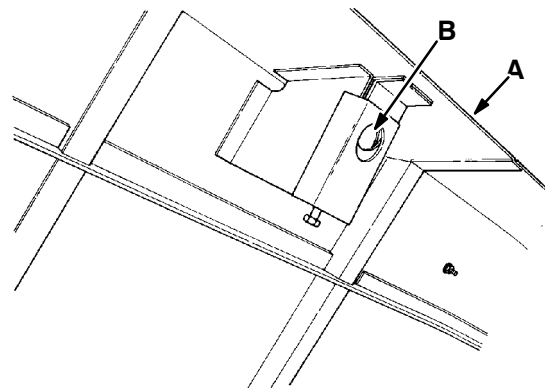

01458

HOPPER COVER LATCH

- A. Hopper Cover
- B. Hopper Cover Latch

SIDE BRUSH PIVOT PINS

The five side brush pivot pins should be lubricated with Lubriplate EMB grease (TENNANT part no. 01433-1) grease after every 200 hours of operation.

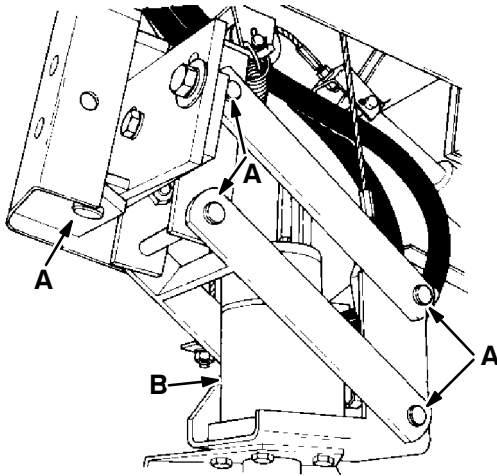

01459

SIDE BRUSH PIVOT PINS

- A. Pivot Pin**
- B. Side Brush Motor**

STABILIZER LEG PIVOT PIN

The stabilizer leg pivot pin should be lubricated with Lubriplate EMB grease (TENNANT part no. 01433-1) grease after every 200 hours of operation.

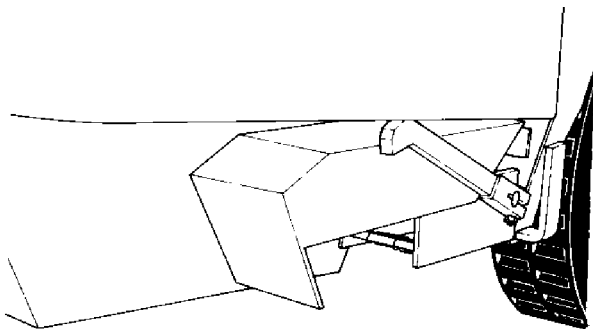

01440

STABILIZER LEG

FRONT WHEEL BEARINGS

The front wheel bearings should be repacked with a good quality wheel bearing grease after every 2000 hours of operation.

The front wheel bearings should be repacked with Lubriplate EMB grease (TENNANT part no. 01433-1) grease after every 2000 hours of operation.

HYDRAULICS

HYDRAULIC FLUID

Hydraulic fluid drives most of the moving components of the machine. The quality and condition of the hydraulic fluid play a very important role in how well the machine operates. TENNANT has developed its own hydraulic fluid to meet the special needs of its machines.

TENNANT Hydraulic Fluid is a specially compounded oil with the following features not found in many hydraulic fluids:

1. Flat viscosity curve.
2. Additives to prevent corrosion.
3. Additives to prevent oxidation.
4. Rust inhibitors.
5. Foam suppressors.

These features restrict foaming of the hydraulic fluid and provide a high standard of lubrication to the components.

TENNANT HYDRAULIC FLUID VISCOSITY SPECIFICATIONS

	TENNANT Hyd. Fluid No. 32397 (HP1040)	TENNANT Hyd. Fluid No. 32398 (HP2060)
SUS @ 100° F (38° C)	404–445	940–1010
SUS @ 210° F (99° C)	78–84	122–130

TENNANT Hydraulic Fluids have a very flat viscosity curve (synonymous with “high viscosity index”). The flat viscosity curve means that the thickness of the fluid is very constant over wide temperature ranges.

Hydraulic fluid with the viscosity rating of 10W40 should be used in machines that are operated in areas which have ambient temperatures up to 90° F (32° C). Use the 20W60 rated hydraulic fluid in areas which have ambient temperatures above 90° F (32° C).

ATTENTION! If a locally-available hydraulic fluid is preferred, or if products of only one oil company are used, the hydraulic fluid used must match closely the viscosity specifications given in the chart for TENNANT Hydraulic Fluid, as well as the other features described. Do not substitute automatic transmission fluid for hydraulic fluid.

ATTENTION! Hydraulic components depend on system hydraulic fluid for internal lubrication. If dirt or other contaminants are allowed to enter the hydraulic system, malfunctions, accelerated wear, and damage will result.

HYDRAULIC FLUID RESERVOIR

Hydraulic fluid is stored in the hydraulic fluid reservoir. The reservoir holds up to 5 gal (19 L) of hydraulic fluid. The reservoir is located in front of the engine.

The reservoir is equipped with a breather-filler cap and fluid level dipstick. See *HYDRAULIC FLUID RESERVOIR BREATHER* for breather service information.

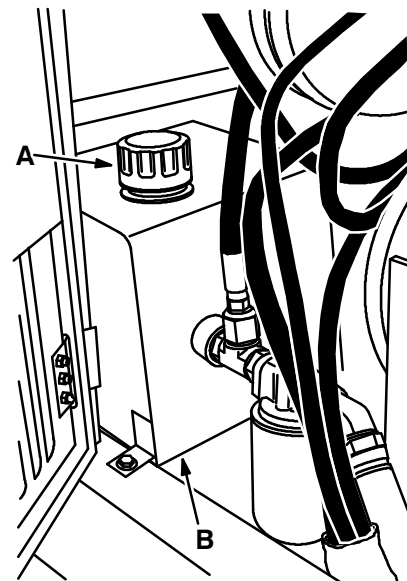

06743

HYDRAULIC FLUID RESERVOIR

- A. Hydraulic Reservoir Breather-Filler Cap
- B. Hydraulic Fluid Reservoir

The hydraulic fluid level dipstick is built into the breather-filler cap. The end of the dipstick is marked with “FULL” and “ADD” levels. This indicates the level of hydraulic fluid in the reservoir.

Check the hydraulic fluid level after every 100 hours of operation. The level should be above the "ADD" mark on the dipstick, but not above the "FULL" mark when the hydraulic fluid is warm.

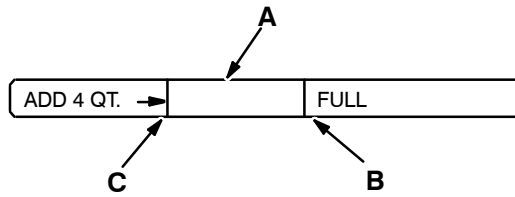

02164
HYDRAULIC FLUID LEVEL DIPSTICK

- A. Dipstick
- B. "FULL" Mark
- C. "ADD" Mark

Do not overfill the hydraulic fluid reservoir. The hydraulic fluid expands as it heats up to its normal operating temperature. Always allow for this expansion when filling the hydraulic fluid reservoir.

ATTENTION! Do not overfill the hydraulic fluid reservoir or operate the machine with a low level of hydraulic fluid in the reservoir. Either one may cause damage to the machine hydraulic system.

Change the hydraulic fluid after every 400 hours of operation.

TO DRAIN THE HYDRAULIC FLUID RESERVOIR

1. Set the machine parking brake and start the engine.

FOR SAFETY: Before Leaving Or Servicing Machine; Stop On Level Surface And Set Parking Brake.

2. Raise the debris hopper to the fully raised position.
3. Position the hopper support bar under the lift arm.



WARNING: Falling Hopper. Engage Hopper Support Bar Before Working Under Hopper.

4. Lower the hopper so the lift arm rests itself on top of the hopper support bar.

5. Stop the engine.
6. Loosen the breather-filler cap. Remove the reservoir drain plug located on the bottom left side of the reservoir to drain the hydraulic fluid. Discard the used hydraulic fluid.

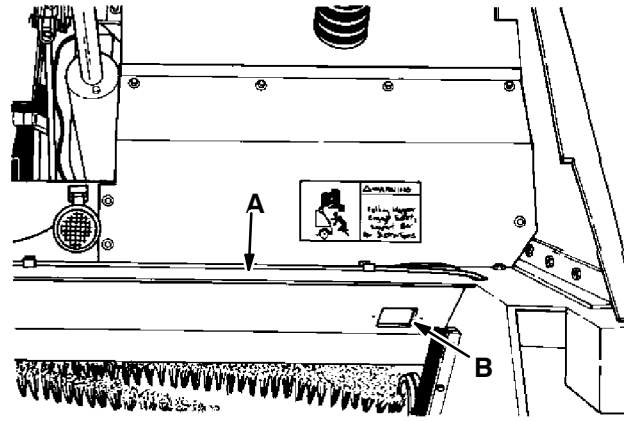

01462
HYDRAULIC FLUID RESERVOIR DRAIN ACCESS CUT-OUT

- A. Machine Frame
- B. Drain Access Cut-Out

NOTE: Always change the hydraulic fluid filter when draining the hydraulic fluid reservoir.

7. Reinstall the reservoir drain plug.

TO FILL THE HYDRAULIC FLUID RESERVOIR

1. Open the left access door.
2. Remove the reservoir breather-filler cap.
3. Pour 5 gal (19 L) of new, approved hydraulic fluid through a 200 mesh screened funnel and into the reservoir filler neck.

ATTENTION! Use only new, approved hydraulic fluid to fill the hydraulic fluid reservoir.

4. Check the hydraulic fluid level in the reservoir with the breather-filler cap dipstick.

MAINTENANCE

5. Add hydraulic fluid until the level in the reservoir is between the "ADD" and "FULL" range. Do not overfill the reservoir.

NOTE: Do not overfill the hydraulic fluid reservoir. The hydraulic fluid expands as it heats up to its normal operating temperature. Always allow for this expansion when filling the hydraulic fluid reservoir.

6. Replace the breather-filler cap.
7. Close the access door.

HYDRAULIC FLUID RESERVOIR BREATHER

The hydraulic fluid reservoir is equipped with a breather. The breather relieves excess atmospheric pressure or vacuum in the reservoir. The breather is mounted on the hydraulic fluid reservoir. The breather should be replaced after every 800 hours of operation.

HYDRAULIC FLUID FILTER

The machine hydraulic system is kept clean to a level of 10 microns by a hydraulic fluid filter. The hydraulic fluid filter is located in the left front of the engine compartment of the machine.

Replace the hydraulic fluid filter element after the first 50 hours of operation and then after every 400 hours of operation.

TO REPLACE THE HYDRAULIC FLUID FILTER ELEMENT

1. Stop the engine and set the machine parking brake.

FOR SAFETY: Before Leaving Or Servicing Machine; Stop On Level Surface, Set Parking Brake, And Turn Off Machine.

2. Open the side engine access door.

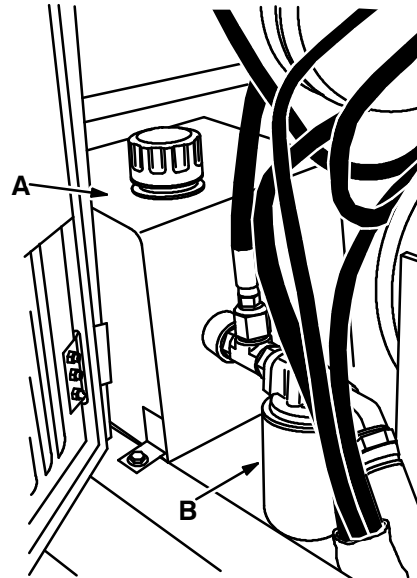

HYDRAULIC FLUID FILTER

06743

- A. Hydraulic Fluid Reservoir**
- B. Hydraulic Fluid Filter Element**

3. Unthread, remove, and discard the hydraulic fluid filter element.

NOTE: Discard all hydraulic fluid drained from the system. Drained hydraulic fluid may contain foreign material harmful to the hydraulic system.

4. Apply a thin coat of hydraulic fluid to the seal of the new hydraulic fluid filter element.
5. Thread the new hydraulic fluid filter on the filter head.
6. Operate the machine and check for leaks. Correct any leaks found.
7. Check the hydraulic fluid reservoir level and fill as required.
8. Close the side engine access door.

HYDRAULIC PUMPS

The machine propelling pump is a variable displacement hydraulic piston pump. It is driven by the engine via a flywheel coupling assembly.

The machine accessories pump is a hydraulic gear pump. It is tandem mounted to the hydraulic piston pump.

After repairing or replacing a hydraulic pump, or when system contamination is likely, change the hydraulic fluid in the reservoir and the hydraulic fluid filter. Then the proper start and break-in procedure must be followed to prevent possible damage to the pump. *TO START AND BREAK-IN HYDRAULIC PUMP* outlines the procedure.

TO START AND BREAK-IN HYDRAULIC PUMP

1. Set the machine parking brake and block the front tires of the machine.

FOR SAFETY: Before Leaving Or Servicing Machine; Stop On Level Surface And Set Parking Brake.

FOR SAFETY: When Servicing Machine, Block Machine Tires Before Jacking Machine Up.

2. Jack up the rear of the machine at the designated locations.

FOR SAFETY: When Servicing Machine, Jack Machine Up At Designated Locations Only. Block Machine Up With Jack Stands.

3. Block up the machine with jack stands.
4. Fill the hydraulic fluid reservoir with 5 gal (19 L) of new-approved hydraulic fluid.
5. Fill the pump case drain with hydraulic fluid. Connect an air pressurizing device to the hydraulic reservoir fill neck and pressurize the reservoir to 5 psi (35 kPa).
6. Loosen the hydraulic fittings at the propelling pump case drain and inlet and the accessory pump inlet to bleed air from the hydraulic hoses.
7. As soon as hydraulic fluid appears at the fittings, retighten the fittings.

8. Operate the engine starter motor for 15 seconds.
9. Start the engine and operate it at a low idle for 30 seconds.
10. Move the directional pedal into the “forward” and “reverse” positions and observe the rear tire for the proper directional rotation.
11. Speed the engine to a fast idle.
12. Press the directional control pedal one-half of its travel in the “forward” direction for three minutes also doing the following: Operate the main brush and side brush; raise and lower the hopper three times; dump and return the hopper to the operating position three times.
13. Check the directional control pedal “neutral” position adjustment.
14. Stop the engine.
15. Raise the rear of the machine, remove the jack stands, and lower the machine.
16. Fill the hydraulic fluid reservoir with new, approved hydraulic fluid.
17. Check the hose routings to be sure the hoses do not contact any moving, hot, or sharp surfaces.
18. Replace the hydraulic fluid filter after the first 50 hours of operation.

DIRECTIONAL CONTROL PEDAL “NEUTRAL” POSITION ADJUSTMENT

After replacing the hydraulic pump or pump linkages, the pump control linkages must be adjusted.

1. Stop the engine and set the machine parking brake.

FOR SAFETY: Before Leaving Or Servicing Machine; Stop On Level Surface, Set Parking Brake, And Turn Off Machine.

MAINTENANCE

2. Jack up the rear of the machine at the designated locations.

FOR SAFETY: When Servicing Machine, Jack Machine Up At Designated Locations Only. Block Machine Up With Jack Stands.

3. Block up the machine with jack stands.
4. Loosen the rod end nut connecting the directional control pedal to the control linkage.
5. Position the middle of the directional control pedal 34° off the floor plate.
6. Tighten the rod end nut connecting the directional control pedal to the control linkage.
7. Start the engine.
8. Loosen the pump centering springs mounting bracket bolts. Center the pump arm around the plate springs. Tighten the bolts.
9. Move the directional control pedal into the “forward” position and release it. The rear wheel should stop rotating as soon as the pedal is released. Adjust the spring mounting bracket position to the rear wheel stops when the pedal is released.
10. Move the directional control pedal into the “reverse” position and release it. The rear wheel should stop rotating as soon as the pedal is released. Adjust the spring mounting bracket position so the rear wheel stops when the pedal is released. Recheck the “forward” position adjustment as in step 9.
11. Stop the engine.
12. Raise the rear of the machine, remove the jack stands, and lower the machine.
13. Adjust the extended shock absorber rod ball joints so the machine does not travel above 6 mph (9.7 km/h) in reverse.
14. Severe Environment Option: Adjust the neutral start switch so that the switch is actuated by the control rod link only when the directional control pedal is in the “neutral” position.

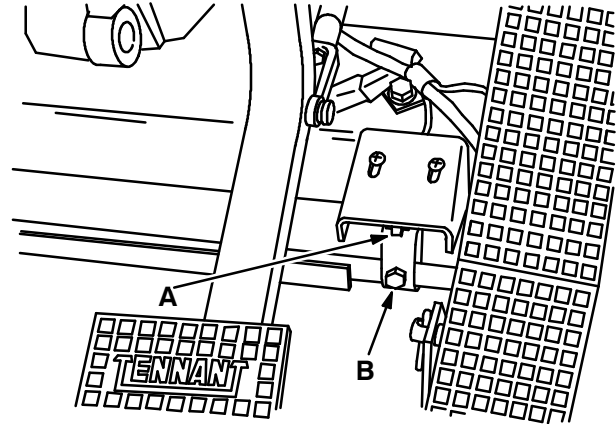

NEUTRAL START SWITCH

- A. Switch**
- B. Link**

06744

SPEED LIMITER

The machine speed limiter is present on the multi-level dump model. The limiter restricts the maximum speed the machine can travel when the hopper is raised. The speed limiter should be adjusted whenever the pump control linkage is adjusted. The machine should not travel more than 2 mph (3.2 km/h) with the hopper raised.

The speed limiter is adjusted by tightening or loosening the speed limiter cable. One threaded end of the cable is located on the right lift arm. The other end of the cable, which is also threaded, is located on a flat sided sheave next to the directional control pedal. Tighten the cable to reduce the machine speed when the hopper is raised. Loosen the cable to increase the machine speed when the hopper is raised.

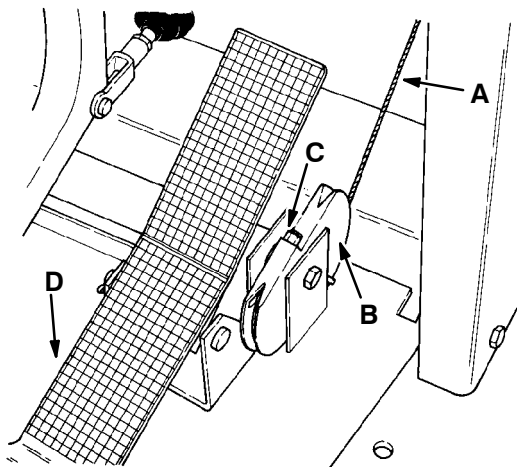

SPEED LIMITER CABLE

- A. Speed Limiter Cable**
- B. Flat Sided Sheave**
- C. Cable Adjusting Nut**
- D. Directional Control Pedal**

01463

HYDRAULIC FLUID LEAKS

Fluid escaping from a very small hole can be almost invisible. Use a piece of cardboard or wood, rather than hands, to search for suspected leaks.

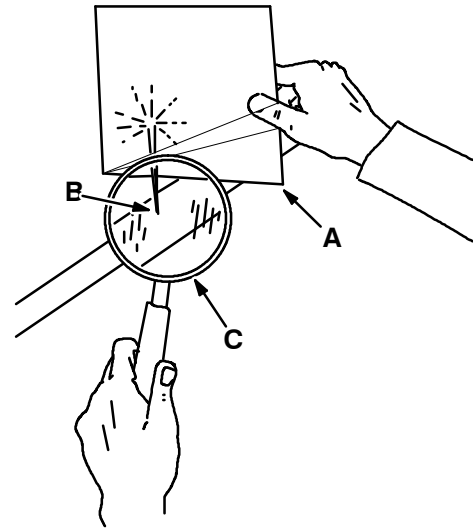

HYDRAULIC PINHOLE LEAK

00002

- A. Cardboard**
- B. Pinhole Leak**
- C. Magnifying Glass**

If injured by escaping fluid, see a doctor at once. Serious infection or reaction can develop if proper medical treatment is not administered immediately.

FOR SAFETY: When Servicing Machine, Use Cardboard To Locate Leaking Hydraulic Fluid Under Pressure.

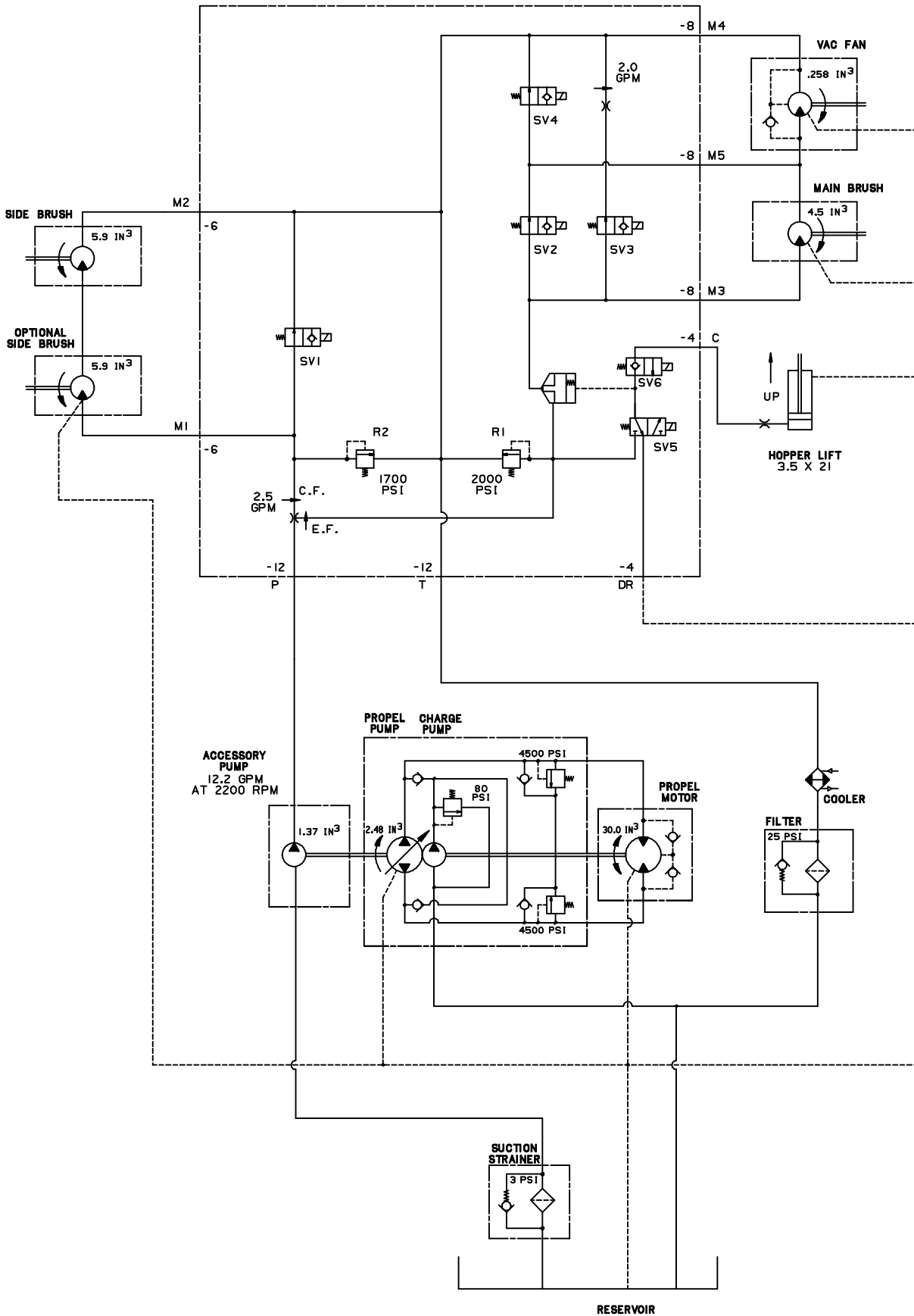

HYDRAULIC SCHEMATIC – LOW DUMP MODEL

06527

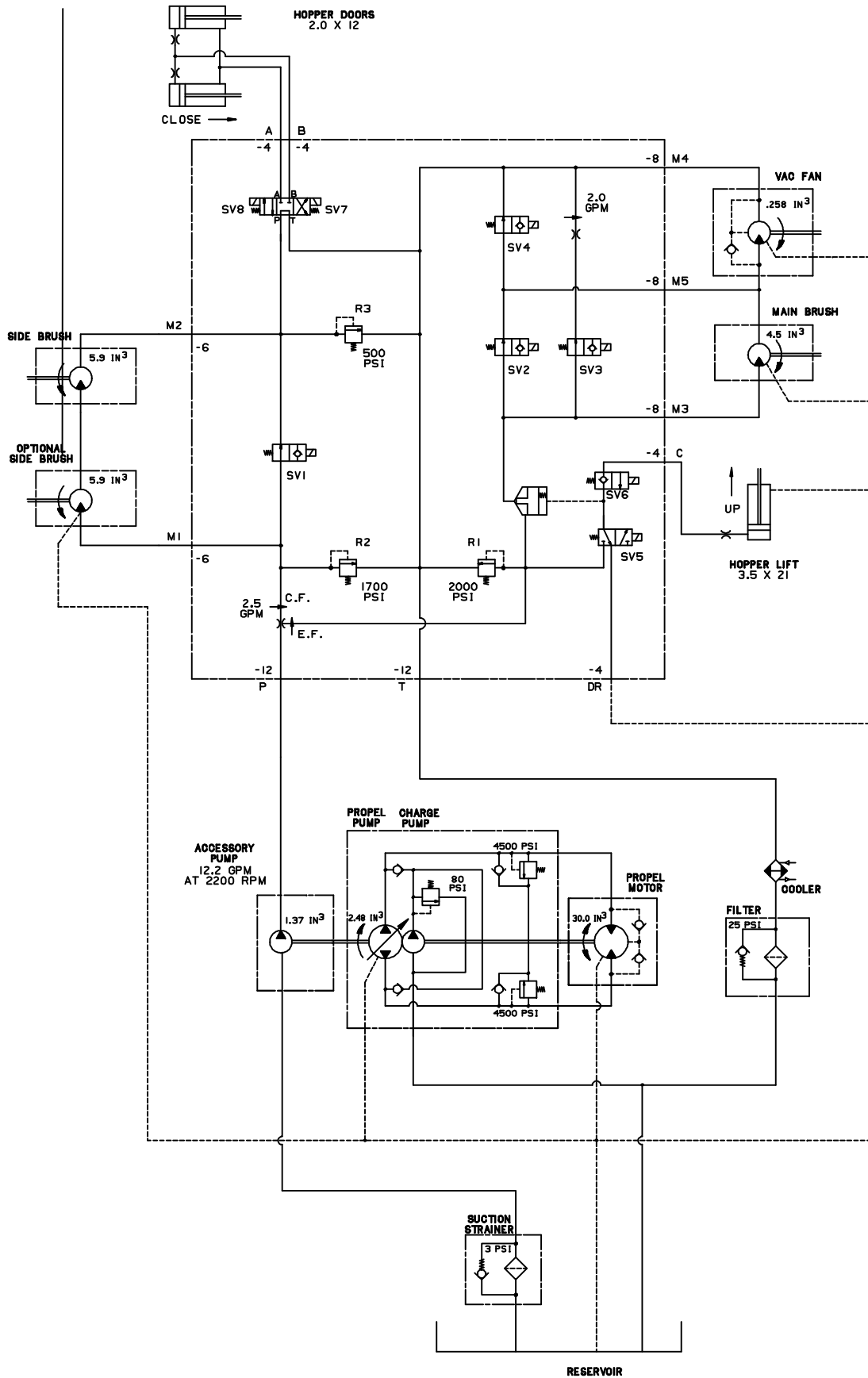

HYDRAULIC SCHEMATIC – MULTI-LEVEL DUMP

06529

Problem	Cause	Remedy
Machine travels slowly or not at all	Parking brake set	Release parking brake
	Directional control linkage broken or not adjusted properly	Replace and/or adjust linkage
	Relief valve stuck open (leaking)	Clean or replace relief valve – one forward, one reverse
	Hydraulic motor failure	See <i>HYDRAULIC COMPONENTS TROUBLESHOOTING</i>
	Hydraulic piston pump failure	See <i>HYDRAULIC COMPONENTS TROUBLESHOOTING</i>
	Hydraulic fluid level low	Fill hydraulic fluid reservoir
Main brush turns slowly or not at all	Bad electrical connections	Remake connections
	Bad rocker switch S4	Replace switch
	Bad hopper switch S1	Replace switch
	Bad relay M3	Replace relay
	Bad thermal sentry switch	Replace switch
	Bad coil SV2	Replace coil
	Cartridge stuck open at SV2	Clean or replace cartridge
	Bad logic board	Replace board
	F1 Priority valve stuck	Clean or replace valve
	Relief valve stuck open R1	Clean or replace valve
	Logic valve stuck closed	Clean or replace valve
	Hydraulic fluid level low	Fill hydraulic fluid reservoir
	Hydraulic brush motor failure	See <i>HYDRAULIC COMPONENTS TROUBLESHOOTING</i>
	Hydraulic gear pump failure	See <i>HYDRAULIC COMPONENTS TROUBLESHOOTING</i>
Main brush turns in I and II speed, but no vacuum fan	Bad electrical connections	Remake connections
	Bad rocker switch S3	Replace switch
	Bad coil SV4	Replace coil
	Cartridge stuck open at SV4	Clean or replace cartridge
	Hydraulic fan motor failure	Replace motor
	Bad logic board	Replace board
No II speed on main brush and vacuum fan	Bad electrical connections	Remake connections
	Bad rocker switch S4	Replace switch
	Bad coil SV3	Replace coil
	Cartridge stuck open at SV3	Clean or replace cartridge
	Bad logic board	Replace board
	No low speed With II speed vacuum fan, main brush continues to run	F2 flow divider plugged
Bad rocker switch S4		Replace switch
Bad coil SV2		Replace coil
Bad logic board		Replace board

MAINTENANCE

Problem	Cause	Remedy
Hopper will not lift	Bad rocker switch S11	Replace switch
	Bad coil SV5	Replace coil
	Cartridge stuck open at SV5	Clean or replace cartridge
	Logic valve stuck open	Clean or replace valve
	Cartridge stuck open at SV6	Clean or replace cartridge
	Hydraulic orifice at lift cylinder plugged	Replace orifice
	Lift cylinder failure	See <i>HYDRAULIC COMPONENTS TROUBLESHOOTING</i>
	Hydraulic gear pump failure	See <i>HYDRAULIC COMPONENTS TROUBLESHOOTING</i>
	Hopper overloaded	Empty hopper
	Lift arms binding	Replace and/or adjust lift arm linkage
Hopper lifts but main brush and vacuum fan do not shut off	Bad hopper switch S1	Replace switch
Hopper will not lower	Bad rocker switch S11	Replace switch
	Bad coil SV6	Replace coil
	Cartridge stuck open at SV6	Clean or replace cartridge
	Cartridge stuck open at SV5	Clean or replace cartridge
	Lift cylinder failure	See <i>HYDRAULIC COMPONENTS TROUBLESHOOTING</i>
	Hydraulic gear pump failure	See <i>HYDRAULIC COMPONENTS TROUBLESHOOTING</i>
	Lift arms binding	Replace and/or adjust lift arm linkage
Hopper door will not open	Bad rocker switch S12	Replace switch
	Bad coil SVA	Replace coil
	Cartridge stuck open at SVA	Clean or replace cartridge
	Relief stuck open R2	Clean or replace valve
	Relief stuck open R3	Clean or replace valve
	Roll out cylinder failure	See <i>HYDRAULIC COMPONENTS TROUBLESHOOTING</i>
	Hydraulic gear pump failure	See <i>HYDRAULIC COMPONENTS TROUBLESHOOTING</i>
Hopper door will not close	Bad rocker switch S12	Replace switch
	Bad coil SVB	Replace coil
	Cartridge stuck open at SVB	Clean or replace cartridge
	Roll out cylinder failure	See <i>HYDRAULIC COMPONENTS TROUBLESHOOTING</i>
	Hydraulic gear pump failure	See <i>HYDRAULIC COMPONENTS TROUBLESHOOTING</i>

Problem	Cause	Remedy
Side brush turns slowly or not at all	Bad electrical connections	Remake connections
	Bad rocker switch S5	Replace switch
	Bad coil SV1	Replace coil
	Cartridge stuck open at SV1	Clean or replace cartridge
	Relief stuck open R2	Clean or replace valve
	Bad logic board	Replace board
	Priority valve stuck	Clean or replace valve
	Hydraulic brush motor failure	See <i>HYDRAULIC COMPONENTS TROUBLESHOOTING</i>
	Hydraulic fluid level low	Fill hydraulic fluid reservoir
	Hydraulic gear pump failure	See <i>HYDRAULIC COMPONENTS TROUBLESHOOTING</i>
Side brush will not lift or lower	Bad electrical connections	Remake connections
	Bad rocker switch S5	Replace switch
	Bad side brush actuator	Replace actuator

MAINTENANCE

HYDRAULIC COMPONENTS TROUBLESHOOTING

Problem	Cause	Remedy
Hydraulic cylinder failure	Piston seals leaking	Install seal kit
	Barrel worn or rod bent	Replace cylinder
Hydraulic motor failure	Motor leaking	Install seal kit
	Drive link failure	Replace drive link
	Gerotor worn	Replace gerotor set
	Output shaft failure	Replace output shaft and bearings
Hydraulic gear pump failure	Pump leaking	Install seal kit
	Gear set failure	Replace gear set
	Shaft failure	Replace gear set
	Flow divider failure	Replace back plate assembly
	Engine-to-pump coupling failure	Replace coupling
	Pump leaking	Install seal kit
	Relief valve stuck	Clean or replace relief valve
Hydraulic piston pump failure	Integral charge pump failure	Replace charge pump
	Rotating group worn	Replace rotating group
	Shaft failure	Replace shaft
	Backplate worn	Replace backplate
	Engine-to-pump coupling failure	Replace coupling

ENGINE

LUBRICATION

Check the engine oil level daily.

Diesel powered engines should be lubricated with SAE–CC/CD rated engine oil. Change the engine oil and oil filter after every 100 hours of operation.

The following oil grades are recommended for engines operating in the ambient temperatures listed.

SINGLE AND MULTI-VISCOSITY OILS		
Below 32°F (Below 0°C)	32° to 77° F (0° to 25° C)	Above 77° F (Above 25° C)
10W	20	30
10W 30		

The engine oil capacity is 8.38 qt (9 L) including the oil filter.

COOLING SYSTEM

Maintaining cooling system efficiency is important. Engine temperatures must be brought up to and maintained within the satisfactory range for efficient operation. However, the engine must be kept from overheating in order to prevent damage to the valves, pistons, and bearings.

Remove and clean the radiator screen daily. The radiator screen can be removed by opening the side engine door, rotating up the top engine door latch, moving the screen retainer clip, and pulling out the radiator screen.

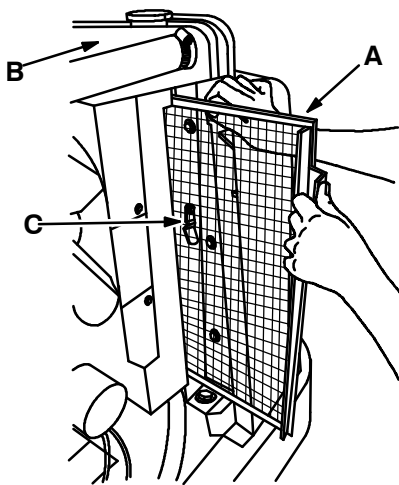

REMOVING RADIATOR SCREEN

- A. Radiator Screen**
- B. Radiator**
- C. Screen Retainer Clip**

06704

Check the coolant level in the radiator every daily. Use soft, clean water mixed with permanent-type, ethylene glycol antifreeze in a one-to-one ratio. Deposits of sludge, scale, and rust prevent normal heat transfer. Flush the radiator and the cooling system after every 800 hours of operation using a dependable cleaning compound. Follow the mixing procedure recommended by the compound manufacturer. This is important because of the difference in concentration and composition of the cleaning compounds. After cleaning, flush the system with clean water.

Whenever a cooling system is badly rust-clogged as indicated by overflow loss or abnormally high operating temperatures, corrective cleaning by reverse flow flushing will most effectively remove the heavy deposits of sludge, rust, and scale. The reverse flow flushing should be performed immediately after draining the cleaning solution. Flush the radiator first, then the engine, to allow the engine to cool as much as possible.

Engine overheating may also be caused by dirty radiator fins. The exterior fins of the radiator and hydraulic cooler can be cleaned with an air hose. Check them for clogging after every 100 hours of operation. Blow out all dust, dirt, etc., between the fins, if necessary. This should be done only after the radiator and cooler have cooled off to avoid cracking caused by uneven cooling. Swing open the left rear door of the machine to gain access to the hydraulic cooler and the radiator.

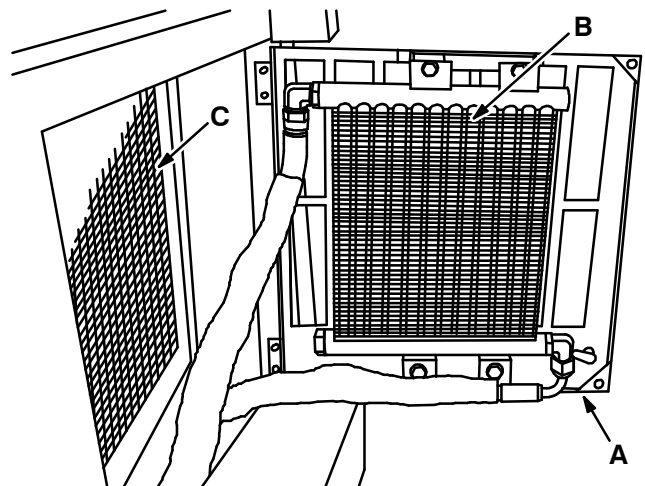

HYDRAULIC COOLER

- A. Left Rear Door**
- B. Hydraulic Cooler**
- C. Radiator**

06746

MAINTENANCE

The engine is equipped with a 180° F (82° C) thermostat. Normal engine temperature is 200° F (93° C). Temperatures up to 220° F (104° C) are allowable. Temperatures over 200° F (93° C) indicate a problem exists.

A pressure cap is used on the radiator to prevent overflow loss of water during normal operation. The spring-loaded valve in the cap closes the outlet to the overflow pipe of the radiator and thus seals the system. Pressure developing within the system raises the boiling point of the coolant and allows higher temperatures without overflow loss from boiling. The pressure valve opens at 15 psi (100 kPa), allowing steam and water to pass out the overflow pipe.

FOR SAFETY: When Servicing Machine, Avoid Contact With Hot Engine Coolant.

ATTENTION! Never pour cold water or cold antifreeze into the radiator of an overheated engine. Allow the engine to cool and avoid the danger of cracking the cylinder head or block. Keep the engine running while adding water.

AIR INTAKE SYSTEM

The importance of maintaining an air filter in proper condition cannot be overemphasized. Dirt induced through improperly installed, improperly serviced, or inadequate air filter elements wears out more engines than long hours of operation. Even a small amount of dirt will wear out a set of piston rings in just a few hours. Operating with a clogged air filter element also causes the fuel mixture to be leaner, which can lead to formation of harmful sludge deposits in the engine. Always cover the air intake when the air filter is removed for servicing. Do not neglect servicing the air filter. Use only approved replacement parts. Keep all other air intake components secure and in good condition to prevent entrance of unfiltered air.

Over-maintenance can cause more damage than good. Removing the air filter element more often than is needed allows contaminants to enter the engine unnecessarily. Clean or replace the air filter element only when the restriction indicator indicates excessive restriction in the system.

AIR FILTER SERVICE INDICATOR

The air filter service indicator signals when to clean or replace the air filter element. Check the service indicator daily. The red line will move on the scale as the air filter element fills with dirt. Do not clean or replace the air filter element until the red line reaches 20 in H₂O (5 kPa) and the "SERVICE WHEN RED" window is filled with red. The service indicator red line may return to a lower reading on the scale when the engine is shut off. The red line will return to a correct reading when the engine is started.

Clean or replace the filter element when the service indicator reads 20 in H₂O (5 kPa). After cleaning or replacing the air filter element, reset the service indicator by pushing the reset button on the end of the indicator.

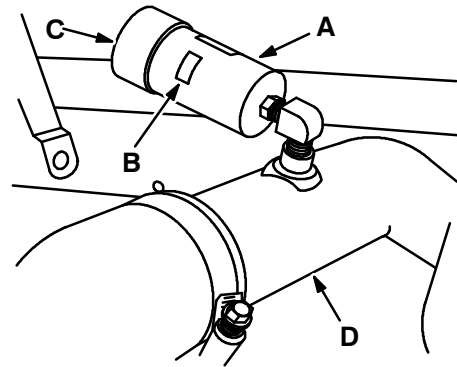

06747

AIR CLEANER SERVICE INDICATOR

- A. Service Indicator**
- B. Red Indicator Window**
- C. Indicator Reset**
- D. Air Intake Tube**

AIR FILTER

The engine air filter element is a dry cartridge-type filter. The air filter element must be cleaned and inspected or replaced whenever the red indicator of the air filter service indicator is visible. The filter must be replaced after it has been damaged or cleaned three times.

Severe Environment Option: The air filter element should not be cleaned, but replaced when the red indicator of the air filter service indicator locks in the visible position.

Service the air filter element only when the service indicator indicates excessive restriction in the system. Do not remove air filter element unless it is restricting air flow.

TO REPLACE AIR FILTER ELEMENT

1. Stop the engine and set the machine parking brake.

FOR SAFETY: Before Leaving Or Servicing Machine; Stop On Level Surface, Set Parking Brake, And Turn Off Machine And Remove Key.

2. Open the right rear access door.
3. Unscrew the clamp ring on the filter.
4. Remove the end cup.
5. Remove the wing nut.
6. Gently pull the element out of the filter housing.

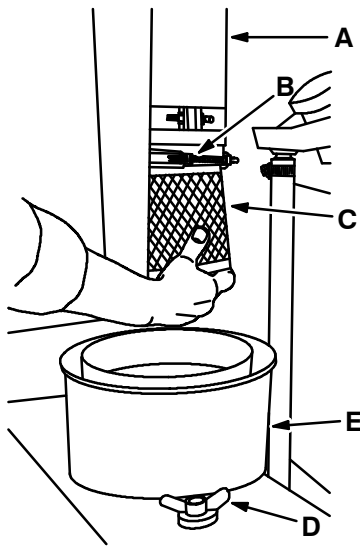

REPLACING AIR FILTER ELEMENT

06748

- A. Filter Housing**
- B. Clamp Ring**
- C. Filter Element**
- D. Wing Nut**
- E. End Cap**

7. Carefully clean out the end cup and interior of the air cleaner housing with a damp cloth. Clean the element housing sealing surfaces.
8. Using an air hose, direct dry, clean air, maximum 30 psi (205 kPa), up and down pleats on the inside of the filter. Do not rap, tap, or pound dust out of the element. Remember, elements may only be safely cleaned three times before they must be replaced.

FOR SAFETY: When Servicing Machine, Wear Eye And Ear Protection When Using Pressurized Air Or Water.

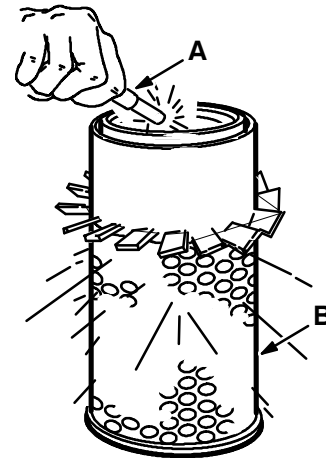

CLEANING AIR FILTER ELEMENT

00051

- A. Air Hose**
- B. Filter Element**

9. After cleaning the air filter element, inspect it for damage by placing a bright light inside. The slightest rupture requires replacement of the filter. Clean and inspect the seals on the end of the element. They should be unbroken and flexible.

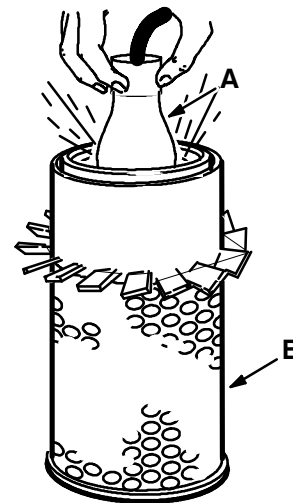

INSPECTING AIR FILTER ELEMENT

00051

- A. Bright Light**
- B. Filter Element**

MAINTENANCE

10. Install the new or cleaned filter element so that the fins on the element are at the intake end of the air cleaner. Use care so that the fins are not damaged. Make sure the element is seating evenly. Tighten the element wing nut.
11. Install the end cap and tighten the clamp ring to hold it in place. Check all intake hose connections for leaks or abrasion.
12. Close the rear access door.
13. Open the engine cover and reset the service indicator.

FUEL SYSTEM

The diesel fuel system is made up of five basic components which are: fuel tank, fuel water trap filter, fuel pump, injection pump, and injectors.

Fuel flows from the fuel tank through the fuel water trap filter. The water trap filter separates water and impurities from the fuel. From the fuel water trap filter, fuel is drawn through the electric fuel pump and pumped to the injection pump. The injection pump pressurizes and sends fuel to the injectors. The injectors atomize and inject proper amounts of fuel into the combustion chamber at the proper times. Excess fuel is returned to the fuel tank through an overflow pipe.

FUEL WATER TRAP FILTER

The fuel water trap filter separates water and impurities from the fuel. It is located next to the fuel tank. The bottom portion of the unit is the water trap, the middle portion is the filter element.

Drain the water trap of water daily. To drain the water trap, loosen the drain knob on the bottom of the unit. First water, then diesel fuel will drain. Tighten the drain knob with diesel fuel appears.

Replace the fuel filter element and clean the water trap after every 400 hours of operation.

TO REPLACE THE FUEL FILTER ELEMENT

1. Stop the engine and set the machine parking brake.

FOR SAFETY: Before Leaving Or Servicing Machine; Stop On Level Surface And Set Parking Brake.

2. Open the right rear access door.
3. Loosen the unit vent plug and open the water trap drain to drain diesel fuel.

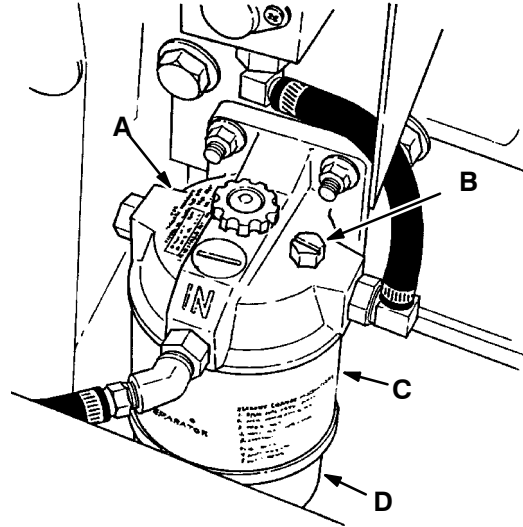

FUEL WATER TRAP FILTER

02765

- A. Filter Head
- B. Vent Plug
- C. Filter Element
- D. Water Trap Bowl

4. Remove the filter element and the water trap from the filter head.
5. Remove the water trap bowl from the filter element.
6. Clean the water trap bowl.
7. Lubricate the o-ring and spin the water trap bowl onto the new filter element.
8. Lubricate the o-ring and spin the filter element and water trap onto the filter head.
9. Prime the fuel system as described in *PRIMING THE FUEL SYSTEM*.
10. Close the right-hand rear door.

FUEL INJECTION PUMP

The fuel injection pump controls the engine speed.

The maximum speed screw is set and sealed by the manufacturer and must not be altered in any way unless factory authority is first obtained. Any adjustments should be carried out by experienced fuel pump technicians. The unauthorized removal of any seals on the pump may void the warranty.

ATTENTION! Unless proper test equipment and trained technicians are available, adjustment or maintenance of the fuel injection pump should not be attempted.

FUEL INJECTORS

When replacing injectors in the cylinder head, it is essential that a new, correct-type heat shield washer be fitted between the nozzle cap and the cylinder head.

Care should be used when replacing the fuel injectors to prevent loosening the injector leak-off nipples.

Be sure to cut a relief in the inside of your socket for clearance. This will prevent an interference between the socket and the leak-off nipple.

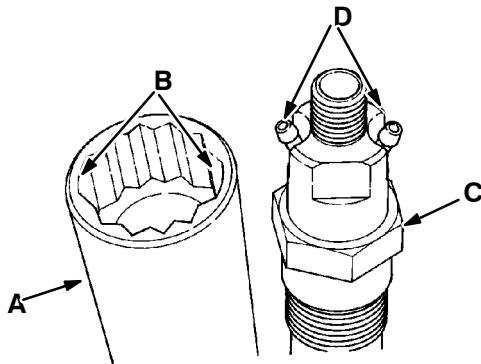

SOCKET RELIEF CLEARANCE

01477

- A. Socket**
- B. Relief**
- C. Injector**
- D. Leak-Off Nipple**

Tighten injectors evenly to 52 ft lb (70 Nm).

Injectors should be taken out only if engine is malfunctioning as outlined below:

- A. Misfiring
- B. Knocking in one (or more) cylinders
- C. Engine overheating
- D. Loss of power
- E. Smoky exhaust (black or white)
- F. Increased fuel consumption

The faulty injector or injectors may be located by loosening the line fitting nut on each, in turn, with the engine running at a fast idle. This allows the fuel to escape and not enter the cylinder. The injector least affecting the engine performance should be removed from the cylinder head and reconditioned or replaced.

! WARNING: Diesel atomizer spray can penetrate skin. Severe personal injury or death can result. Keep away from atomizers when engine is in operation.

NOTE: No attempt should be made to adjust the injection pressure without a proper testing pump and pressure gauge. It is impossible to adjust the setting of the injector with any degree of accuracy without proper equipment.

! WARNING: Do not start the engine with loose injector securing nuts; this may result in the injector flying out.

MAINTENANCE

TO PRIME FUEL SYSTEM

Priming the fuel system removes pockets of air in the fuel lines and fuel components. Air in the fuel system will prevent smooth engine operation.

Prime the fuel system after running out of fuel, changing fuel filter elements or repairing a fuel system component.

Before priming and venting, ensure that the outside of the vent screws and surrounding area is thoroughly clean to prevent dirt and foreign matter from entering the system.

NOTE: Electrical equipment such as starters should be shielded during priming to prevent fuel entry.

TO PRIME THE FUEL SYSTEM

1. Stop the engine and set the machine parking brake.

FOR SAFETY: Before Leaving Or Servicing Machine; Stop On Level Surface And Set Parking Brake.

2. Fill the fuel tank.
3. Open the side and top engine doors.

4. Open the air vent on top of the fuel injection pump.

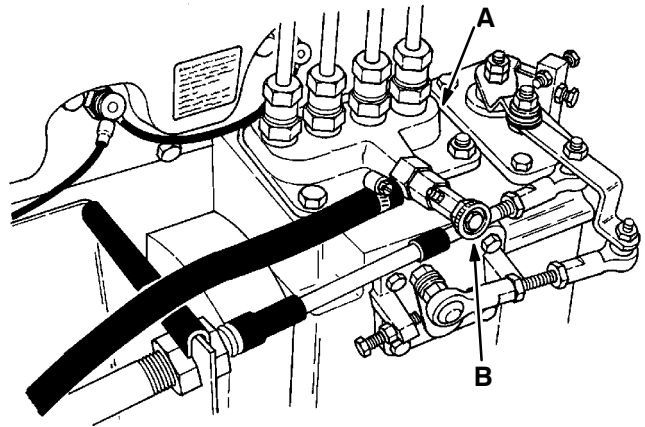

INJECTION PUMP VENTS

06749

- A. Injection Pump**
- B. Air Vent**

5. Start the engine and operate it for one minute, then stop the engine; or operate the starter motor in ten-second intervals until a steady stream of fuel flows from the vent.
6. Close the air vent
7. Close the engine doors.

DIESEL FUEL TROUBLESHOOTING

Problem	Cause	Remedy
Engine will not start	Out of fuel	Fill fuel tank
	Filter plugged	Clean filter
	Air in fuel	Bleed fuel lines
	Water in fuel	Drain water trap
	Fuel too thick	Change fuel grade
	Battery discharged	Charge or replace battery
	Clogged fuel nozzle	Clean or replace nozzle
	Valve clearance wrong	Adjust valves
	Leaking valves	Grind valves
Engine runs unevenly or lacks power	Low compression	Repair engine
	Dirty air filter	Clean or replace filter
	Plugged fuel filter	Clean filter
	Water in fuel	Drain water trap
	Fuel too thick	Change fuel grade
	Clogged fuel nozzle	Clean or replace nozzle
	Low compression	Repair engine
	Engine overheating	Check radiator Check lubricating system
	Valve clearance wrong	Adjust valves
Engine stops suddenly	Injection pump worn	Repair or replace pump
	Fuel leak	Check fuel system
	Out of fuel	Fill fuel tank
	Fuel nozzle bad	Replace nozzle
	Engine overheating	Check radiator Check lubricating system
Exhaust color bad	Fuel governor failure	Repair or replace
	Bad fuel	Change fuel grade
	Fuel nozzle bad	Replace nozzle
	Low compression	Repair engine
	Valve clearance wrong	Adjust valves
	Injection pump worn	Repair or replace pump

MAINTENANCE

CYLINDER HEAD

CYLINDER HEAD

The cylinder head must be properly torqued after servicing to ensure proper operation. A three-stage torque procedure should be used. Snug down the cylinder head bolts and nuts in the proper sequence; first to one-third, then two-thirds, and then to the full torque specification of 58 to 68 ft lb (79 to 83 Nm). Retighten the bolts and nuts after operating the engine for 30 minutes.

NOTE: Power wrench torque limit must be held at least 10 ft lb (15 Nm) below torque specification. Hand tighten to specification.

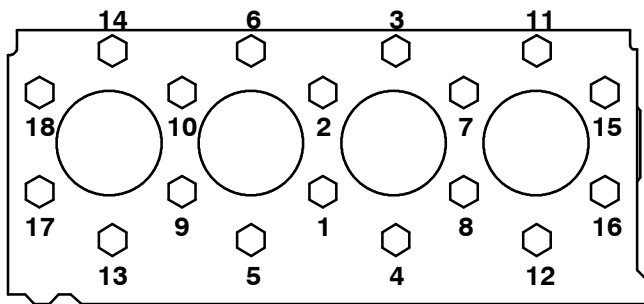

CYLINDER HEAD BOLT TIGHTENING SEQUENCE

VALVE CLEARANCE

The valve clearance must be properly adjusted after servicing or retorquing the cylinder head bolts to ensure proper operation. Measure the clearance with a feeler gauge after aligning each cylinder with the top dead center of compression.

Adjust them with the engine cool to 0.0071 to 0.0087 in (0.18 to 0.22 mm) in the firing order of 1–3–4–2.

ELECTRICAL SYSTEM

BATTERY

The battery is rated at 12 V, 625 ccA. It is located under the operator seat. When removing battery cables, remove the negative (–) cable before the positive (+) cable.

Do not allow the battery to remain in discharged condition for any length of time.

Do not operate the machine if the battery is in poor condition or with only 25% of the charge left.

Clean the top surface and the terminals of the battery periodically. Use a strong solution of baking soda and water. Brush the solution sparingly over the battery top, terminals, and cable clamps. Do not allow any baking soda solution to enter the battery. Use a wire brush to clean the terminal posts and the cable connectors. After cleaning, apply a coating of clear petroleum jelly to the terminals and the cable connectors. Keep the top of the battery clean and dry.

Keep all metallic objects off the top of the battery, as they may cause a short circuit. Replace worn or damaged wires.

The electrolyte level must always be above the battery plates. Add distilled water to maintain solution at the correct level above the plates, but do not overfill. Never add acid to batteries, only water. Keep vent plugs firmly in place at all times, except when adding water or taking hydrometer readings.

FOR SAFETY: When Servicing Machine, Avoid Contact With Battery Acid.

If when checking battery specific gravity, one or more battery cells tests lower than the other battery cells, (0.050 or more) the cell is damaged, shorted, or is about to fail.

NOTE: Do not take readings immediately after adding water – –if the water and acid are not thoroughly mixed, the readings may not be accurate. Check the hydrometer readings against this chart:

SPECIFIC GRAVITY AT 80° F (27° C)	BATTERY CONDITION
1.265	100% charged
1.225	75% charged
1.190	50% charged
1.155	25% charged
1.120	Discharged

NOTE: If the readings are taken when the battery electrolyte is any temperature other than 80° F (27° C), the reading must be temperature corrected.

To determine the corrected specific gravity reading when the temperature of the battery electrolyte is other than 80° F (27° C):

Add to the specific gravity reading 0.004, 4 points, for each 10° F (6° C) above 80° F (27° C).

Subtract from the specific gravity reading 0.004, 4 points for each 10° F (6° C) below 80° F (27° C).

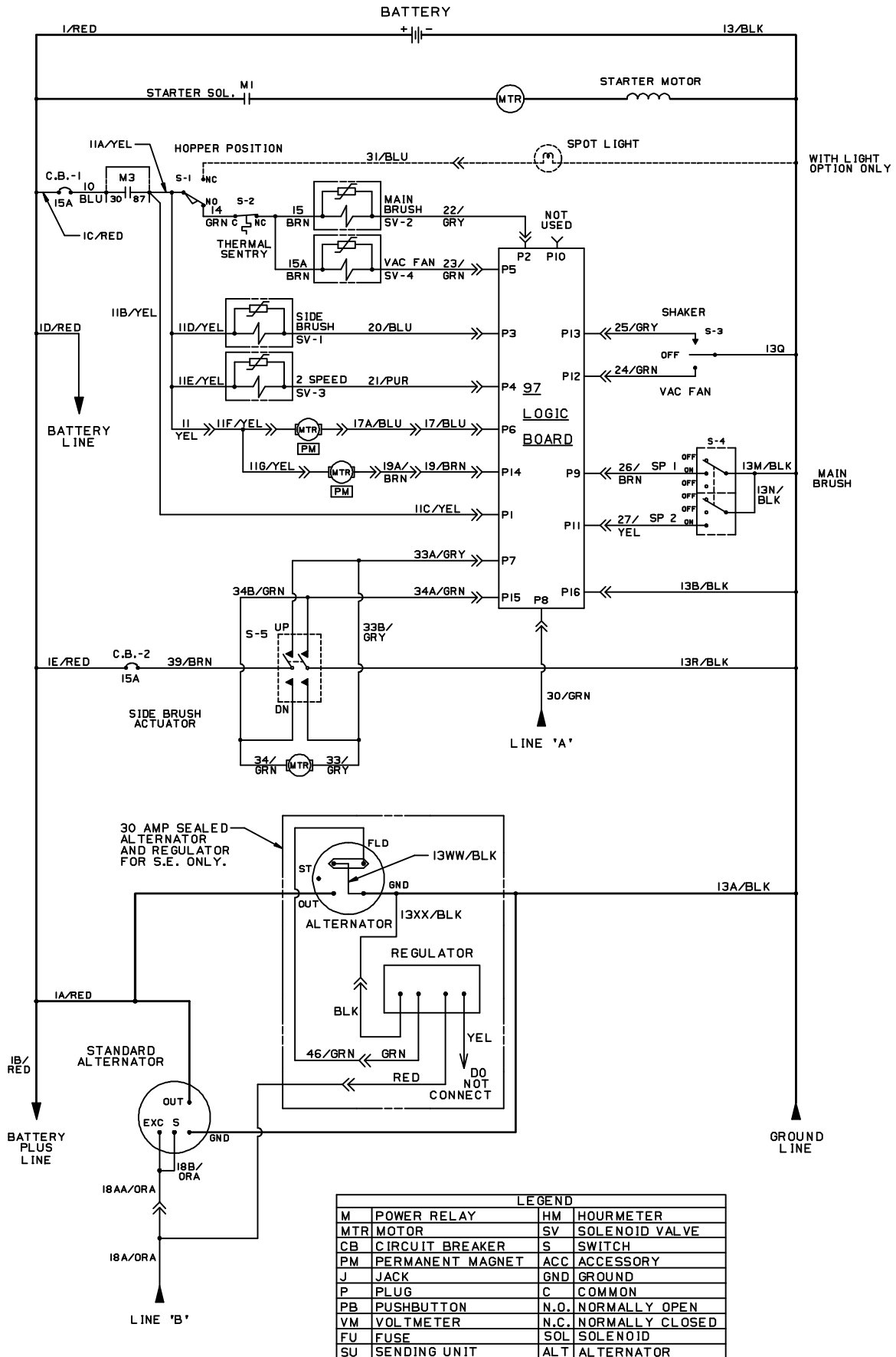

ELECTRICAL SCHEMATIC

06525

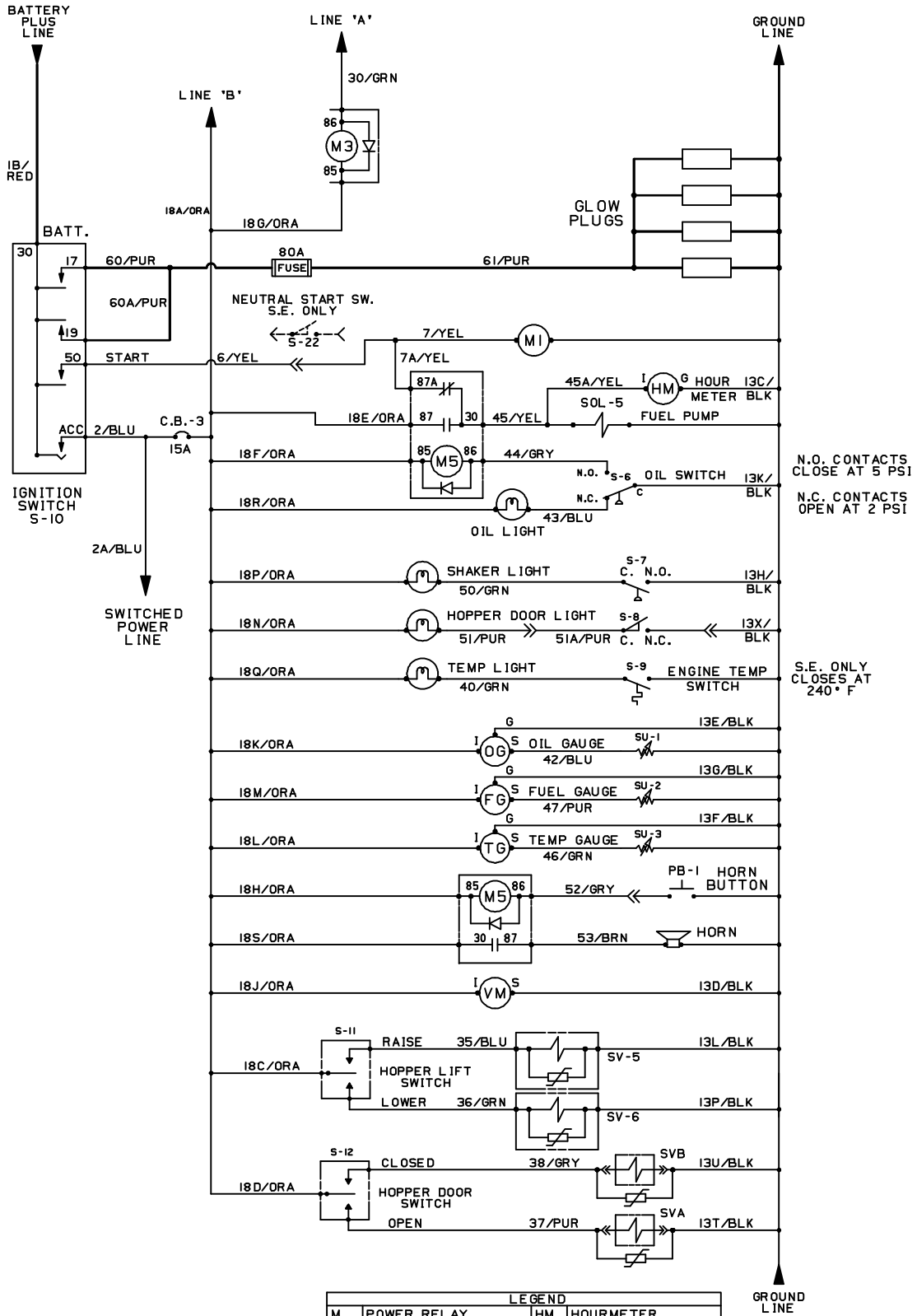

ELECTRICAL SCHEMATIC

06525

MAINTENANCE

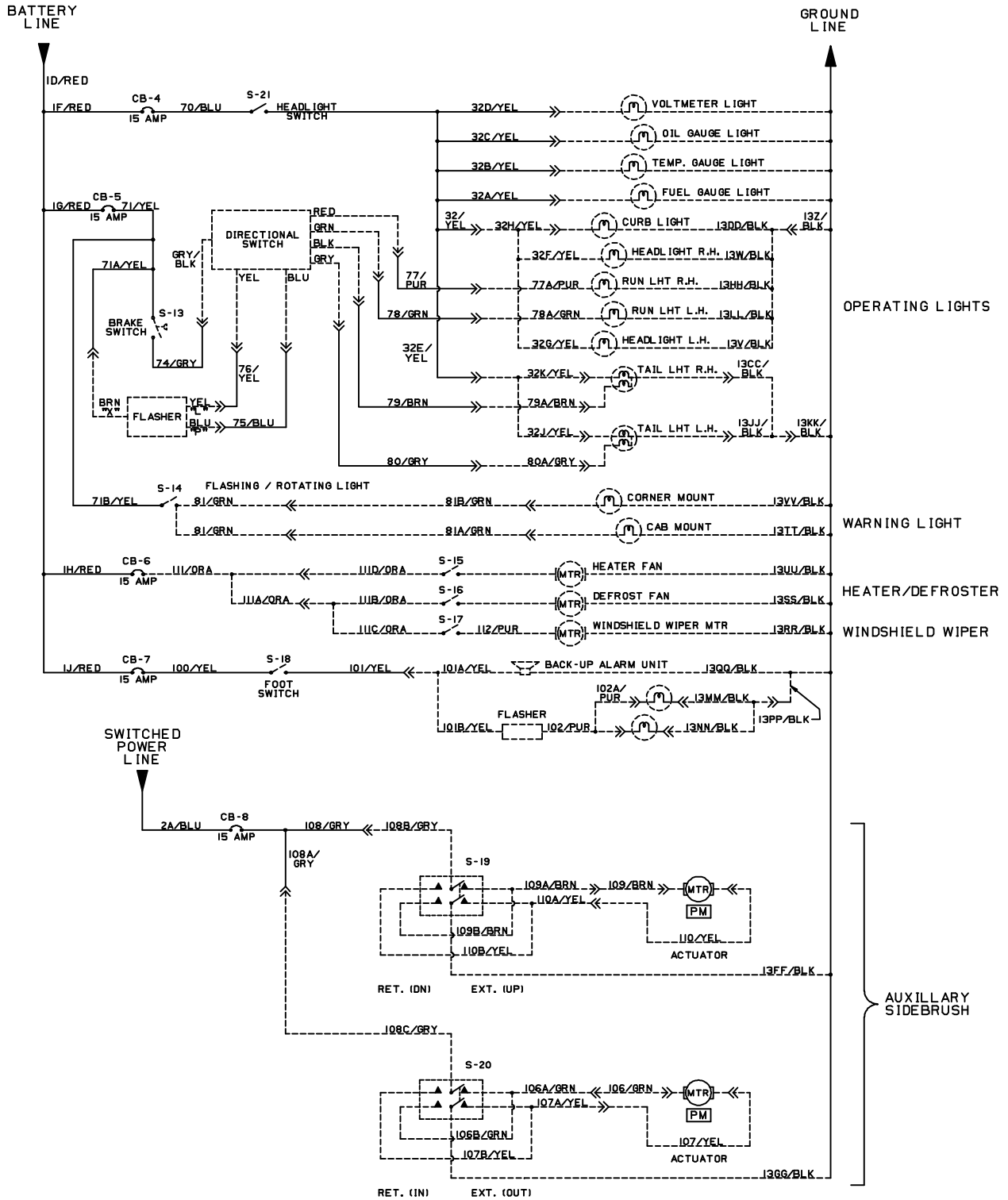

LEGEND			
M	POWER RELAY	HM	HOURLMETER
MTR	MOTOR	SV	SOLENOID VALVE
CB	CIRCUIT BREAKER	S	SWITCH
PM	PERMANENT MAGNET	ACC	ACCESSORY
J	JACK	GND	GROUND
P	PLUG	C	COMMON
PB	PUSHBUTTON	N.O.	NORMALLY OPEN
VM	VOLTMETER	N.C.	NORMALLY CLOSED
FU	FUSE	SOL	SOLENOID
SU	SENDING UNIT	ALT	ALTERNATOR

06525

ELECTRICAL SCHEMATIC

BELTS AND CHAINS

ENGINE FAN BELT

To tighten the fan belt, loosen the alternator adjusting bolts and pull out on the alternator by hand until the belt is just snug. Under no circumstances should a pry bar be used on the alternator to obtain fan belt tension, as damage to the bearings will result. Then tighten the alternator adjusting bolts.

Check the fan belt tension after every 50 hours of operation.

Proper belt tension is obtained when the belt deflects 0.28 in (7 mm) from a force of a finger applied at the midpoint of the longest span.

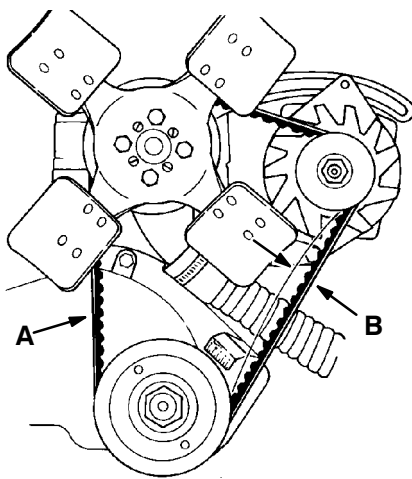

ENGINE FAN BELT

- A. Fan Belt**
- B. Belt Deflection**

00577

STATIC DRAG CHAIN

A static drag chain is provided to prevent the buildup of static electricity in the machine. The chain is attached to the machine by a rear brush skirt retaining bolt.

Check the chain for wear. Make sure that it is making contact with the floor at all times.

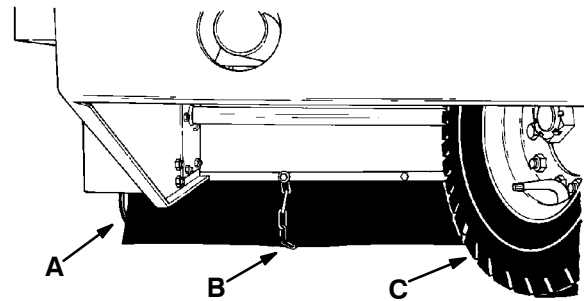

STATIC DRAG CHAIN

- A. Rear Dust Skirt**
- B. Static Drag Chain**
- C. Rear Tire**

01479

DEBRIS HOPPER

HOPPER DUST FILTERS

There are two dust filter panels located inside of the hopper. The dust filters filter the air which is drawn up from the main brush compartment through the hopper. The dust filters are equipped with shaker motors to remove the accumulated loose dust particles. The dust filter shaker motors are operated by the filter shaker and vacuum fan switch. Shake the dust filters before dumping the hopper and at the end of every work shift. Inspect and clean or replace the dust filters after every 100 hours of operation.

To clean the dust filters use one of the following methods:

- **TAPPING** – Tap the filter gently on a flat surface with the dirty side down. Do not damage the edges of the filter element or the filter will not seat properly in the filter frame.
- **AIR** – Blow compressed air, 100 psi (690 kPa) maximum, through the dust filter opposite the direction of the arrows. This may be done with the dust filters in the hopper.
- **WATER** – Soak the dust filter in a water and mild detergent solution. Rinse the dust filter until it is clean. The maximum water pressure allowable is 40 psi (275 kPa). Air dry the wet dust filter; do not use compressed air.

NOTE: Be sure the dust filters are dry before reinstalling them in the machine.

TO REMOVE HOPPER DUST FILTER PANELS

1. Lower the hopper to the sweeping position.
2. Stop the engine and set the machine parking brake.

FOR SAFETY: Before Leaving Or Servicing Machine; Stop On Level Surface, Set Parking Brake, And Turn Off Machine And Remove Key.

3. Release the latches on both sides of the hopper cover.
4. Push in the hopper cover latch release button and lift the hopper cover.

5. Unclip the hopper cover prop arm from its storage location and position it in the hopper cover.
6. Lower the hopper cover onto the prop arm.
7. Unlatch the filter shaker frame and lift up the front of the frame. The filter panels can be removed without removing the filter shaker frame. When doing this, be careful not to bunch the panel seals when removing or installing the filter panels.

If the filter shaker frame is removed to remove the filter panels, unplug the two shaker motors from the machine wire harness before removing the shaker frame.

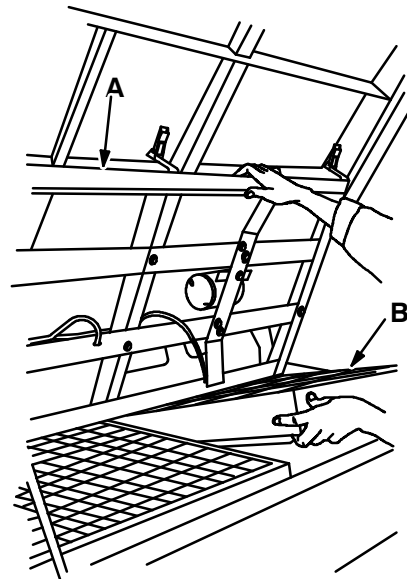

REMOVING FILTER PANELS

- A. Filter Shaker Frame**
- B. Dust Filter Panel**

8. Remove the dust filter panels.
9. Clean or discard the dust filter panels as required.

06750

TO INSTALL HOPPER DUST FILTERS

1. Place the cleaned or new dust filter panels in the hopper dust filter frames with the arrows pointing up. Be careful not to bunch the panel seals when installing the filter panels.
2. Place the filter shaker frame over the dust filter panels. Plug in the shaker motors if the filter shaker frame was removed.
3. Close the filter shaker frame over the dust filter panels and latch the frame in place.
4. Push the hopper cover open, lower and store the prop arm in its retaining clip, and close and latch the hopper cover.

THERMO-SENTRY™

The Thermo-Sentry™ is a thermostat that senses the temperature of the air drawn into the vacuum fan from the hopper. The thermostat controls the solenoid valve that directs hydraulic fluid to the vacuum fan motor. In the event of a fire in the hopper, the high air temperature would trip the thermostat stopping the electric current to the solenoid valve – stopping hydraulic fluid flow to the vacuum fan motor and air flow to the fire. After the thermostat has tripped, it must be manually reset by pushing the reset button in.

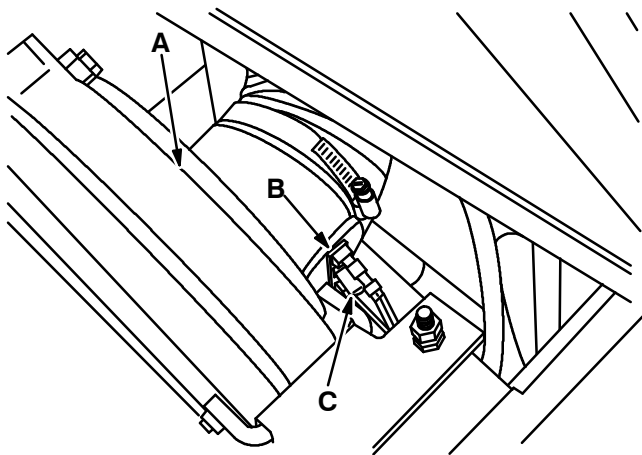

THERMO-SENTRY™

06751

- A. Vacuum Fan**
- B. Thermo-Sentry™**
- C. Reset Button**

DEBRIS HOPPER

The low dump model debris hopper has three adjustments. They are: front bumper alignment, hopper centering adjustment, and hopper floor clearance adjustment.

The multi-level dump model debris hopper has six adjustments. They are: front bumper alignment, hopper centering adjustment, dump height adjustment, dump door and switch adjustment, dump door stop bolts adjustment, and hopper floor clearance adjustment.

All of the adjustments have been made at the factory. Only the hopper floor clearance adjustment should be checked after every 50 hours of operation. In the event that the hopper, the hopper lift arms, or other integral hopper components are repaired or replaced, the hopper must be readjusted for best performance.

The hopper adjustments must be made in the order specified. After making these adjustments, check the side brush adjustments too.

TO ADJUST HOPPER

A. FRONT BUMPER ALIGNMENT – LOW DUMP, MULTI-LEVEL DUMP MODELS

1. Empty the debris hopper.
2. Place the hopper in the sweeping position.
3. Stop the engine and set the machine parking brake.

FOR SAFETY: Before Leaving Or Servicing Machine; Stop On Level Surface, Set Parking Brake, And Turn Off Machine And Remove Key.

4. Position a 24 in (610 mm) long straight edge with one-half of the straight edge on the top of the front bumper, and one-half on the machine side bumper. The bumpers should be level within 0.09 in (2 mm).

To adjust the front bumper, loosen the alignment bolt jam nuts on the side which is most out of alignment. Rotate the alignment bolts until the bumper is level and tighten the jam nuts. Repeat the procedure on the other side if necessary.

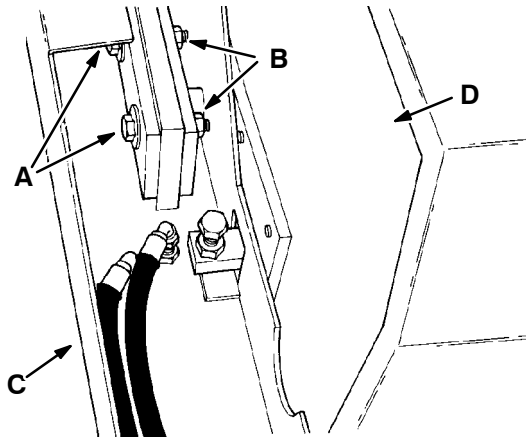

01485

FRONT BUMPER ALIGNMENT BOLT

- A. Alignment Bolt
- B. Jam Nut
- C. Front Bumper
- D. Hopper

B. HOPPER CENTERING ADJUSTMENT – LOW DUMP, MULTI-LEVEL DUMP MODELS

Measure the distance between the right and left side of the hopper and the main frame. The distance measured should be equal within 0.2 in (5 mm).

To adjust the hopper position, raise the hopper and engage the hopper support bar.

! WARNING: Falling Hopper. Engage Hopper Support Bar Before Working Under Hopper.

Open the hopper access door. Turn the set screw inside the hopper adjuster plate recess to the left on the side with less space between the hopper and the frame. Turn the set screw on the other side to the right to reduce the space between the hopper and the frame. Close the hopper access door.

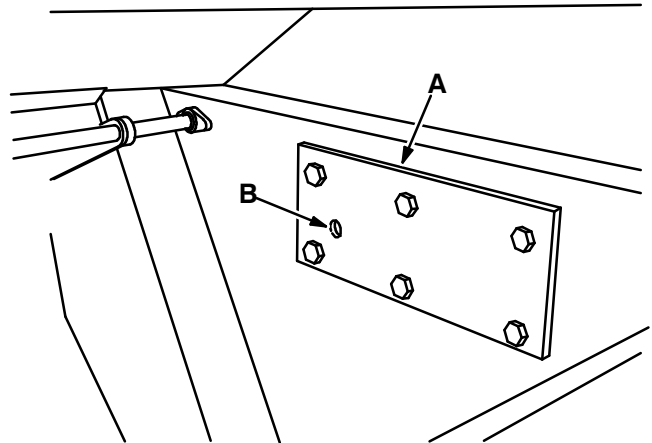

06752

HOPPER ADJUSTER PLATE

- A. Hopper Adjuster Plate
- B. Set Screw

C. DUMP HEIGHT ADJUSTMENT – MULTI-LEVEL DUMP MODEL

Close the hopper door. Measure the distance between the floor and the lowest point on the hopper. It should be 60.5 in (1535 mm).

To adjust the dump height, loosen the lift cylinder clevis jam nut and turn it as far as it will go back towards the cylinder. Continue to rotate the nut to rotate the cylinder rod to adjust the dump height. Loosen the jam nut and retighten it against the cylinder clevis.

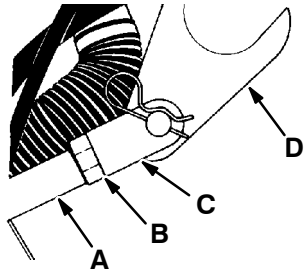

LIFT CYLINDER CLEVIS

- A. Lift Cylinder Rod**
- B. Jam Nut**
- C. Clevis**
- D. Lift Arm**

NOTE: Be sure to keep the clevis thread fully engaged to prevent clevis separation.

**D. HOPPER DOOR AND SWITCH ADJUSTMENT
– MULTI-LEVEL DUMP MODEL**

Open the hopper door. Position a straight edge on the bottom of the hopper and the hopper door. The hopper door should be flat with respect to the bottom of the hopper.

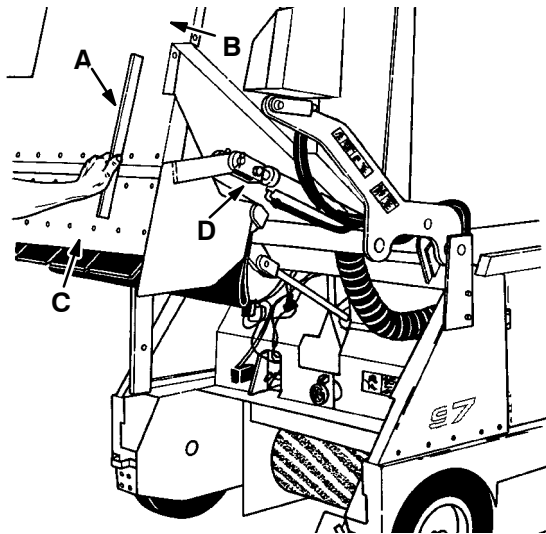

CHECKING DUMP DOOR

- A. Straight Edge**
- B. Hopper Bottom**
- C. Hopper Door**
- D. Door Cylinder**

To adjust the hopper door, loosen the door cylinder clevis jam nuts and turn them as far as they will go back towards the cylinder. Rotate the cylinder rod in the clevis end to adjust the hopper door open position. Tighten the jam nuts when the hopper door base is flat with respect to the hopper bottom.

01508

NOTE: Be sure to keep the clevis thread fully engaged.

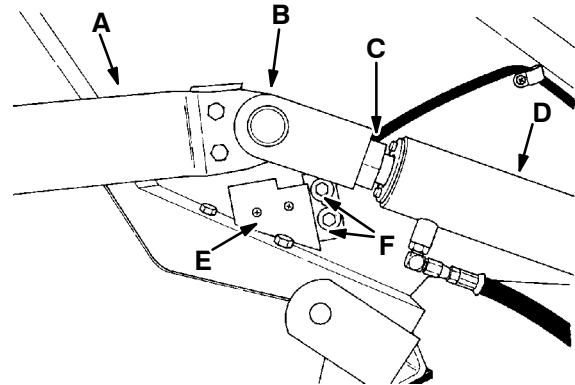

DOOR CYLINDER AND SWITCH

01505

- A. Hopper Door Arm**
- B. Clevis**
- C. Jam Nut**
- D. Door Cylinder**
- E. Switch Bracket**
- F. Adjustment Slot**

Adjust the hopper door switch by loosening the bolts, sliding the switch and bracket up or down, and tightening the bolts so that the switch contacts close when the hopper door is fully open.

06796

E. HOPPER DOOR STOP BOLTS ADJUSTMENT – MULTI-LEVEL DUMP MODEL

Adjust the two hopper door stop bolts so they are 3.1 in (80 mm) long. This will stop the door in the correct “closed” position.

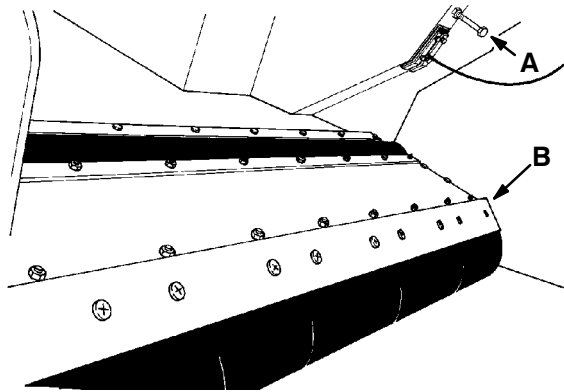

HOPPER DOOR STOP BOLT

01487

- A. Stop Bolt
- B. Hopper Door

F. HOPPER FLOOR CLEARANCE ADJUSTMENT – LOW DUMP, MULTI-LEVEL DUMP MODELS

The hopper floor clearance should be checked after every 50 hours of operation. Proper floor clearance must be maintained to prevent the hopper from trailing debris.

TO CHECK AND ADJUST HOPPER FLOOR CLEARANCE

1. Lower the hopper into the sweeping position, stop the engine, and set the parking brake.

FOR SAFETY: Before Leaving Or Servicing Machine; Stop On Level Surface, Set Parking Brake, And Turn Off Machine And Remove Key.

2. Slide a 1.5 in (40 mm) thick block under each side of the rear of the hopper. This is the amount of floor clearance needed by the hopper. If the hopper needs adjustment, continue.

3. Loosen the floor clearance bolt jam nut on each side of the hopper.

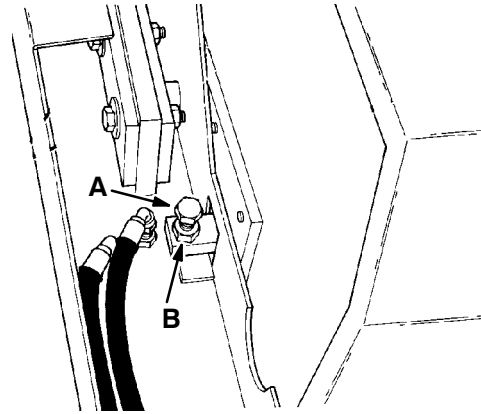

01485

FLOOR CLEARANCE ADJUSTMENT BOLT

- A. Floor Clearance Bolt
- B. Jam Nut

4. Thread the floor clearance bolts in to increase the floor clearance or thread the clearance bolts out to decrease floor clearance.
5. Tighten the jam nuts.

G. OTHER ADJUSTMENTS

After replacing an integral hopper component and making the previous adjustments, also readjust the side brush, the hopper dust dump door, and the hinged top hopper seal on the multi-level dump model.

STABILIZER LEG

The machine stabilizer leg is a safety device which, when the machine is being multi-level dumped, projects downward to act as an anti-tipping device. Check the stabilizer leg daily to be sure it is down when the machine is being multi-level dumped and is fully retracted when the hopper is in the sweeping position. Check for proper operation daily. Lubricate the leg pivot pin after every 200 hours of operation.

TO ADJUST STABILIZER LEG

1. Lower the hopper into the sweeping position.
2. Stop the engine and set the machine parking brake.
3. Check to see if the front bumper is not resting on the stabilizer leg assembly. If it is, loosen the leg assembly mounting bolts, slide the leg assembly down, and retighten the bolts.
4. Loosen the activating arm pinch bolt.
5. Hold the stabilizer leg fully raised.

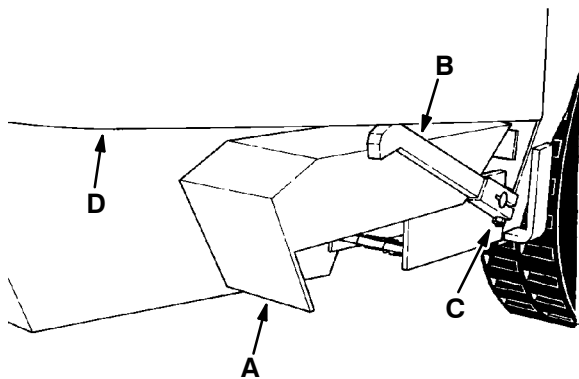

01440

STABILIZER LEG

- A. Stabilizer Leg**
- B. Arm**
- C. Pinch Bolt**
- D. Bumper**

6. Position the arm so it contacts the bottom of the front bumper and tighten the pinch bolt.
7. Start the engine and raise the hopper. Check to make sure the stabilizer leg is lowered.
8. Lower the hopper and check to make sure the leg is fully retracted and raised.

BRUSHES

MAIN BRUSH

The main brush should be inspected daily for wear or damage. Remove any string or wire found tangled on the main brush, main brush drive hub, or main brush idler hub.

Rotate the main brush end-for-end after every 50 hours of operation for maximum main brush life.

The main brush should be replaced when the remaining bristle measures 1.25 in (30 mm) in length.

The main brush pattern should be checked daily. The pattern should be 2 to 2.5 in (50 to 65 mm) wide with the main brush in the (Main Brush Free-Float) position. Main brush pattern adjustments are made by turning the main brush height adjustment knob behind the access door next to the operator's left foot.

TO REMOVE MAIN BRUSH

1. Stop the engine and set the machine parking brake.

FOR SAFETY: Before Leaving Or Servicing Machine; Stop On Level Surface, Set Parking Brake, And Turn Off Machine And Remove Key.

2. Place the main brush position lever in the top (Main Brush Free-Float) position.
3. Open the right side brush access door.
4. Remove the brush idler arm retaining bolt from the arm hub.

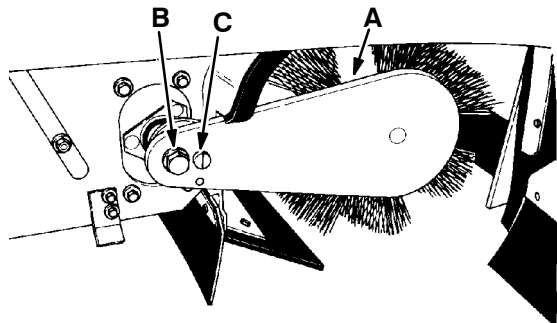

01486

MAIN BRUSH IDLER ARM

- A. Brush Idler Arm**
- B. Arm Retaining Bolt**
- C. Plastic Screw**

5. Pull the brush idler arm off the arm hub.

NOTE: If the brush idler arm does not come off easily, remove the plastic screw which is located next to the hole where the brush idler arm retaining bolt was mounted. Thread the brush idler arm retaining bolt into the threaded hole where the plastic screw was mounted. Tighten the retaining bolt until it forces the brush idler arm loose. Remove the brush idler arm retaining bolt and replace it with the plastic screw.

6. Grasp the main brush; pull it off the brush drive plug and out of the main brush compartment.

TO INSTALL MAIN BRUSH

1. Place the main brush on the floor next to the access door.
2. Align the main brush tube spline with the spline drive on the main brush drive plug.
3. Slide the main brush into the brush compartment and onto the drive plug.
4. Align the main brush idler plug spline with the main brush tube spline.
5. Slide the main brush idler plug into the main brush tube.
6. Slide the brush idler arm onto the arm hub.
7. Thread the brush idler arm retaining bolt through the idler arm and into the arm hub.
8. Tighten the brush idler arm retaining bolt.
9. Close the right side brush access door.
10. Check and adjust the main brush pattern as described in *TO CHECK AND ADJUST MAIN BRUSH PATTERN*.

TO CHECK AND ADJUST MAIN BRUSH PATTERN

1. Apply chalk, or some other material that will not blow away easily, to a smooth, level floor.
2. With the side brush and main brush raised, position the main brush over the chalked area.
3. Start the main brush rotating, while keeping a foot on the brakes to keep the machine from moving.
4. Lower the main brush to the floor for 15 to 20 seconds.

NOTE: If no chalk or other material is available, allow the brushes to spin for two minutes.

5. Raise the main brush.
6. Drive the machine off the test area.
7. Observe the width of the brush pattern. The proper brush pattern width is 2 to 2.5 in (51 to 54 mm).

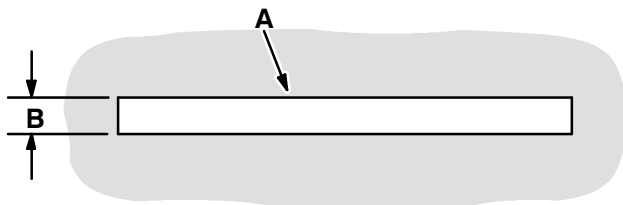

NORMAL MAIN BRUSH PATTERN

00582

- A. Main Brush Pattern**
- B. 2 to 2.5 in (51 to 54 mm)**

To increase the main brush pattern width, loosen the locking wing nut and turn the main brush height adjustment knob to the left from the top. To decrease the main brush pattern width, loosen the locking wing nut and turn the adjustment knob to the right from the top.

Tighten the locking wing nut and recheck the main brush pattern. Repeat the procedure until the main brush pattern is within the specified range.

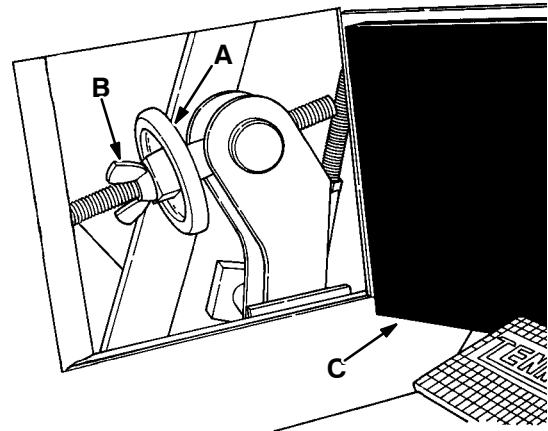

06797

MAIN BRUSH HEIGHT ADJUSTMENT KNOB

- A. Main Brush Height Adjustment Knob**
- B. Wing Nut**
- C. Access Door**

If the main brush pattern is tapered, loosen the left main brush cross shaft bearing mounting brackets and bearing flanges. Pivot the bearing mounting bracket to level the cross shaft. Tighten the bearing mounting bracket and the bearing flanges. Check the main brush pattern and readjust as necessary. Then adjust the width of the main brush pattern.

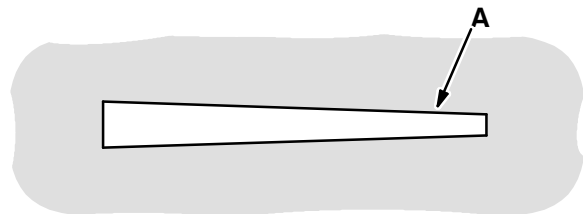

00601

TAPERED MAIN BRUSH PATTERN

- A. Main Brush Pattern**

SIDE BRUSH

The side brush should be inspected daily for wear or damage. Remove any string or wire found tangled on the side brush or side brush drive hub.

The side brush should be replaced when the remaining brush bristle measures 2.5 in (65 mm) in length.

The side brush has four adjustments. The only adjustment which requires regular attention compensates for side brush wear. It is controlled by the side brush height adjustment knob and cable.

To adjust the lowered height, lower the side brush. Loosen the side brush knob. Slide it forward to lower the side brush, or slide it backward to raise the side brush. Tighten the knob after the desired height is reached.

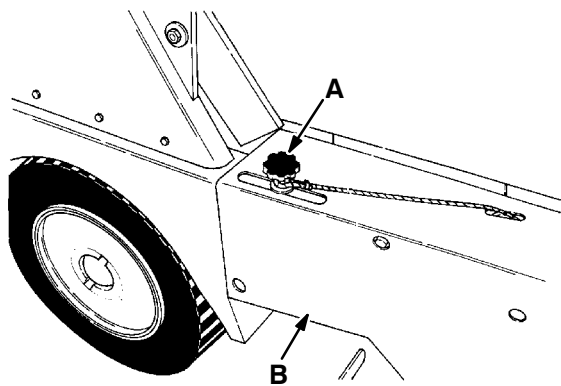

SIDE BRUSH HEIGHT ADJUSTMENT KNOB

- A. Adjustment Knob**
- B. Side Brush Bumper**

The other three adjustments are the maximum raised height adjustment, the side brush height angle adjustment, and the side brush bumper clearance adjustment. These adjustments should be done after replacing any major component of the side brush lift mechanism and after readjusting the hopper.

TO REMOVE SIDE BRUSH

1. Stop the engine and set the machine parking brake.

FOR SAFETY: Before Leaving Or Servicing Machine; Stop On Level Surface, Set Parking Brake, And Turn Off Machine And Remove Key.

2. Raise the side brush.
3. Remove the side brush retaining bolt from the end of the side brush motor drive shaft.

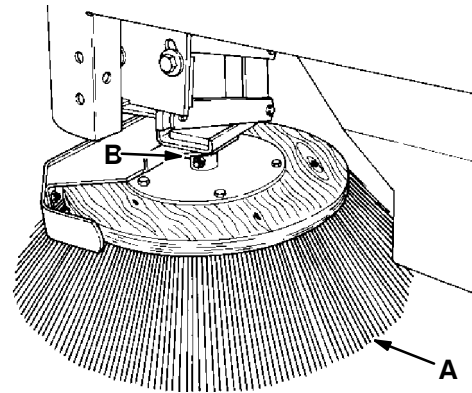

SIDE BRUSH

- A. Side Brush**
- B. Drive Shaft**

4. Slide the side brush off the side brush drive shaft. Keep track of the drive shaft key when removing the brush.

TO INSTALL SIDE BRUSH

1. Slide the side brush onto the side brush drive shaft. Insert the drive shaft key if necessary.
2. Insert the retaining bolt in the end of the side brush drive shaft and tighten the retaining bolt.
3. Adjust the side brush height as described in *TO ADJUST SIDE BRUSH MAXIMUM RAISED HEIGHT*.

TO ADJUST SIDE BRUSH MAXIMUM RAISED HEIGHT

1. Empty the hopper.
2. Park the machine on a level surface and set the parking brake.

FOR SAFETY: Before Leaving Or Servicing Machine; Stop On Level Surface And Set Parking Brake.

3. Raise the hopper, engage the hopper support bar, and lower the hopper onto the support bar.

⚠ WARNING: Falling Hopper. Engage Hopper Support Bar Before Working Under Hopper.

4. Lower the side brush.
5. Stop the engine.
6. Loosen the side brush stop bolts.
7. Position the side brush stop down so the bottom of the side brush is 1 in (25 mm) from the floor when it is in the raised position. Tighten the stop bolts.

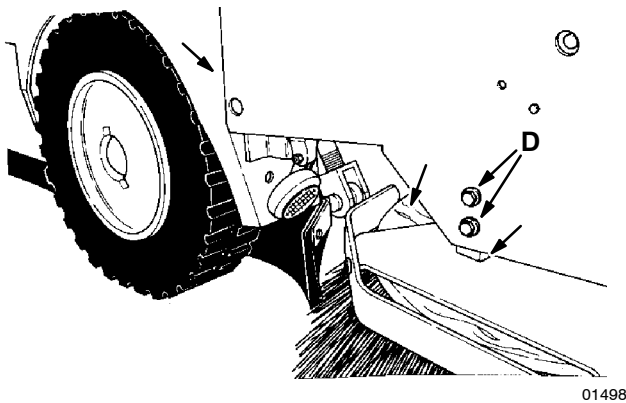

SIDE BRUSH STOP

01498

- A. Stop**
- B. Bumper**
- C. Side Brush Back**
- D. Stop Bolt**

8. Check the side brush raised height.
9. Start the engine, raise the hopper, disengage the hopper support bar, and lower the hopper.
10. Stop the engine.

TO ADJUST SIDE BRUSH HEIGHT ANGLE

1. Raise the side brush.
2. Stop the engine and set the machine parking brake.

FOR SAFETY: Before Leaving Or Servicing Machine; Stop On Level Surface, Set Parking Brake, And Turn Off Machine And Remove Key.

3. Loosen the two side brush angle adjustment bolts.

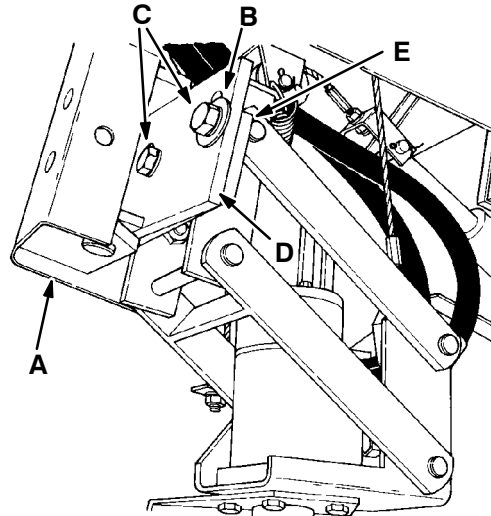

01459

SIDE BRUSH ANGLE ADJUSTMENT

- A. Side Brush Bumper**
- B. Adjustment Slot**
- C. Angle Adjustment Bolt**
- D. Side Edge of Side Brush Pivot**
- E. Side Edge of Side Brush Suspension Bracket**

4. Line up the side edges of the side brush pivot and the side brush suspension bracket to set the side brush angle at 5°.

NOTE: The side brush normally operates at a 5° angle. The angle may be changed to a different angle if the application requires.

5. Tighten the two side brush angle adjustment bolts.

MAINTENANCE

TO ADJUST SIDE BRUSH BUMPER CLEARANCE

1. Empty the hopper.
2. Park the machine on a level surface and set the parking brake.

FOR SAFETY: Before Leaving Or Servicing Machine; Stop On Level Surface, Set Parking Brake, And Turn Off Machine And Remove Key.

3. Raise the hopper, engage the hopper support bar, and lower the hopper onto the support bar.

⚠ WARNING: Falling Hopper. Engage Hopper Support Bar Before Working Under Hopper.

4. Stop the engine.
5. Loosen the bumper clearance bolt jam nut and adjust the bolt so there is 2.45 in (60 mm) clearance between the bumper and the side brush assembly. Tighten the jam nut.

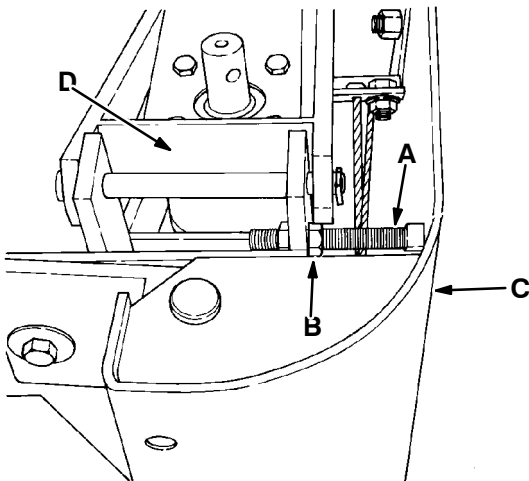

01507

SIDE BRUSH BUMPER CLEARANCE BOLT

- A. Clearance Bolt**
- B. Jam Nut**
- C. Bumper**
- D. Side Brush Assembly**

6. Start the engine, raise the hopper, disengage the hopper support bar, and lower the hopper.
7. Stop the engine.

SKIRTS AND SEALS

HOPPER LIP SKIRTS

The hopper lip skirts are located on the bottom rear of the hopper. Their purpose is to float over debris and help deflect that debris into the hopper. The hopper lip skirts are made up of five bottom lip segments.

The hopper lip skirts should be inspected for wear or damage daily.

TO REPLACE HOPPER LIP

1. Empty the debris hopper.
2. Park the machine on a level surface and set the machine parking brake.

FOR SAFETY: Before Leaving Or Servicing Machine; Stop On Level Surface, Set Parking Brake, And Turn Off Machine And Remove Key.

3. Raise the hopper, engage the hopper support bar, and lower the hopper onto the hopper support bar.

! WARNING: Falling Hopper. Engage Hopper Support Bar Before Working Under Hopper.

4. Stop the engine.
5. Remove the hopper lip retaining strip retaining bolts.
6. Remove the hopper lip retaining strip and worn or damaged hopper lip segments.

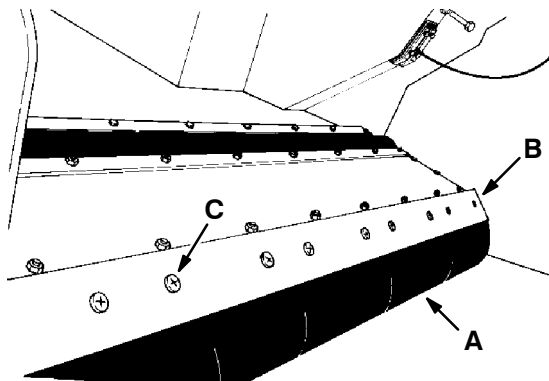

HOPPER LIP SKIRT

01487

- A. Hopper Lip Skirts**
- B. Retaining Strip**
- C. Retaining Bolts**

7. Thread the retaining strip mounting bolts through the retaining strip, the hopper lip segments, and into the hopper.
8. Tighten the mounting bolts.
9. Start the engine. Raise the hopper, lower the hopper support bar, and lower the hopper.
10. Stop the engine.

HOPPER SIDE SEALS

There are two seals, located on the machine frame, that serve as hopper seals. They are the left and right hopper side seals. The seals should be inspected for wear or damage after every 100 hours of operation.

TO REPLACE HOPPER SIDE SEALS

1. Empty the debris hopper.
2. Park the machine on a level surface and set the machine parking brake.

FOR SAFETY: Before Leaving Or Servicing Machine; Stop On Level Surface, Set Parking Brake, And Turn Off Machine And Remove Key.

3. Raise the hopper, engage the hopper support bar, and lower the hopper onto the hopper support bar.

! WARNING: Falling Hopper. Engage Hopper Support Bar Before Working Under Hopper.

4. Stop the engine.

MAINTENANCE

5. Remove the hopper side seal retaining strip retaining bolts.

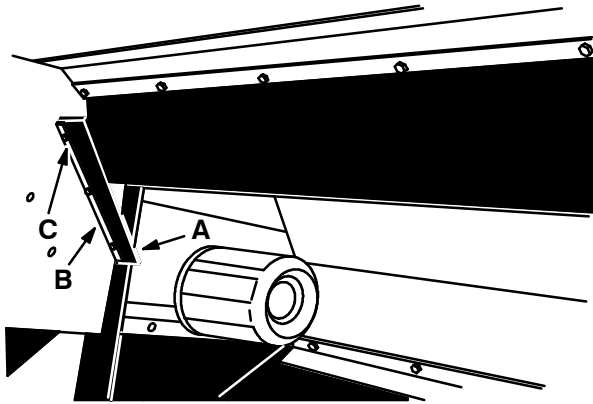

HOPPER SIDE SEALS

06798

- A. Hopper Side Seal
- B. Seal Retaining Strip
- C. Retaining Bolt

6. Remove the hopper side seal retaining strip and hopper side seal.
7. Thread the retaining strip mounting bolts through the retaining strip, the hopper side seal, and into the machine frame.
8. Tighten the mounting bolts.
9. Start the engine. Raise the hopper, lower the hopper support bar, and lower the hopper.
10. Stop the engine.

BRUSH DOOR SKIRTS

The brush door skirts are located on the bottom of each of the two brush compartment doors. These skirts seal the brush compartment. The seals should be inspected for wear or damage daily.

TO REPLACE AND ADJUST BRUSH DOOR SKIRTS

1. Park the machine on a smooth, level surface.
2. Stop the engine and set the machine parking brake.

FOR SAFETY: Before Leaving Or Servicing Machine; Stop On Level Surface, Set Parking Brake, And Turn Off Machine And Remove Key.

3. Open the brush door.

4. Remove the brush door skirt retaining bolts.

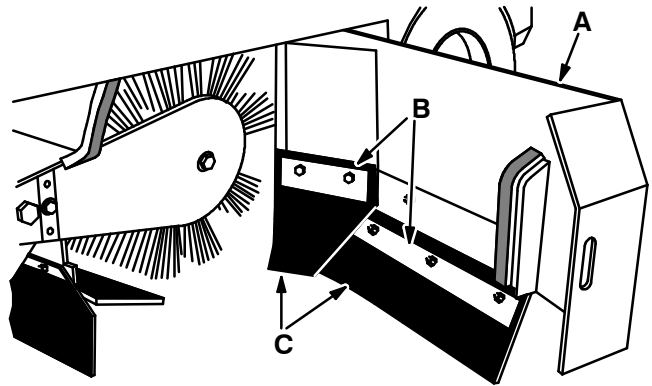

BRUSH DOOR SKIRT

06753

- A. Brush Door
- B. Skirt Retaining Strip
- C. Brush Door Skirt

5. Remove the skirt retaining strip and the door skirt.
6. Position the new door skirt and skirt retaining strip on the brush door.
7. Thread the skirt retaining bolts through the brush door, the door skirt, and into the skirt retaining strip.

NOTE: The brush door skirts have slotted holes to allow for a ground clearance adjustment. The door must be closed for proper adjustment.

8. Slide the brush door skirt up or down so that the skirt clears the floor up to a maximum clearance of 0.12 in (3 mm).
9. Tighten the skirt retaining bolts.
10. Close the brush door.

REAR SKIRTS

The rear skirts are located on the bottom rear of the brush compartment. These skirts seal the brush compartment. The seals should be inspected for wear or damage daily.

TO REPLACE AND ADJUST REAR SKIRTS

1. Park the machine on a smooth, level surface.
2. Stop the engine and set the machine parking brake.

FOR SAFETY: Before Leaving Or Servicing Machine; Stop On Level Surface, Set Parking Brake, And Turn Off Machine And Remove Key.

3. Open the two brush compartment doors.
4. Remove the main brush as described in *TO REMOVE MAIN BRUSH*.
5. Remove the front skirt mounting bracket retaining bolts.
6. Remove the skirt mounting bracket, the rear floor skirt, and the brush contact skirt.

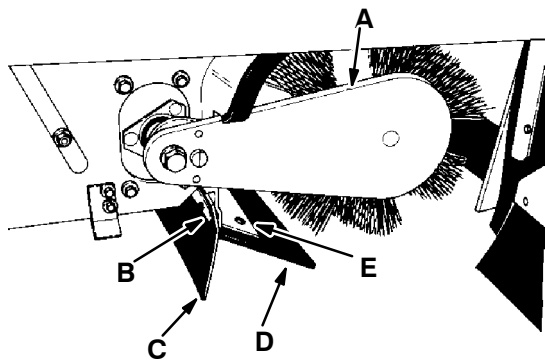

REAR SKIRTS

01486

- A. Brush Idler Arm**
- B. Skirt Retaining Strip**
- C. Rear Floor Skirt**
- D. Brush Contact Skirt**
- E. Skirt Mounting Bracket**

7. Remove the brush contact skirt from the skirt mounting bracket.
8. Mount a new brush contact skirt to the skirt mounting bracket.

9. Position a new floor skirt, floor skirt retaining strip, and the brush contact skirt and mounting bracket on the machine.
10. Thread the skirt mounting bracket retaining bolts through the skirts mounting bracket, the floor contact skirt, the floor contact retaining strip and into the nuts.
11. Slide the rear floor skirt up or down so that the skirt clears the floor up to a maximum clearance of 0.12 in (3 mm).
12. Tighten the retaining bolts.
13. Install the brush as described in *TO INSTALL MAIN BRUSH*.

HOPPER DUST DUMP DOOR SEAL

The hopper dust dump door seal seals the rear opening of the filter cavity. The door opens when the hopper is dumped to allow dust shaken out of the dust filters to exit the filter cavity. The door is made up of a seal and an actuating lever assembly. Check the seal for wear, damage, and adjustment after every 100 hours of operation.

TO REPLACE DUST DUMP DOOR SEAL

1. Empty the hopper.
2. Park the machine on a level surface and set the machine parking brake.

FOR SAFETY: Before Leaving Or Servicing Machine; Stop On Level Surface, Set Parking Brake, And Turn Off Machine And Remove Key.

3. Raise the hopper, engage the hopper support support bar, and lower the hopper onto the support bar.

! WARNING: Falling Hopper. Engage Hopper Support Bar Before Working Under Hopper.

4. Stop the engine.

5. Unbolt the seal and seal backing plate from the cross shaft.

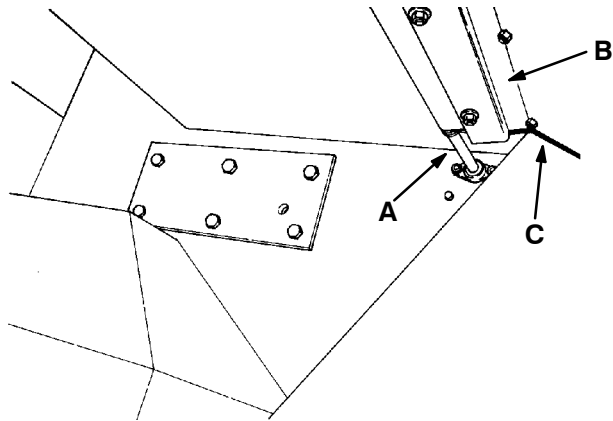

HOPPER DUST DUMP DOOR SEAL

01506

- A. Cross Shaft**
- B. Seal Backing Plate**
- C. Seal**

6. Remove the seal from the seal backing plate.
7. Install a new seal on the backing plate.
8. Bolt the seal and backing plate to the cross shaft.
9. Check the seal adjustment as described in *TO CHECK AND ADJUST HOPPER DUST DUMP DOOR SEAL*.

TO CHECK AND ADJUST HOPPER DUST DUMP DOOR SEAL

1. Empty the hopper.
2. Park the machine on a level surface and set the machine parking brake.

FOR SAFETY: Before Leaving Or Servicing Machine; Stop On Level Surface, Set Parking Brake, And Turn Off Machine And Remove Key.

3. Raise the hopper, engage the hopper support bar, and lower the hopper onto the support bar.



WARNING: Falling Hopper. Engage Hopper Support Bar Before Working Under Hopper.

4. Stop the engine.
5. Check the seal for wear or damage, replace if necessary.

6. Start the engine, raise the hopper, and disengage the hopper support bar.
7. Have an assistant watch the dust dump door cam follower as the hopper lowers. The cam should contact the upper corner and ride on top of the main frame and close the dust dump door.

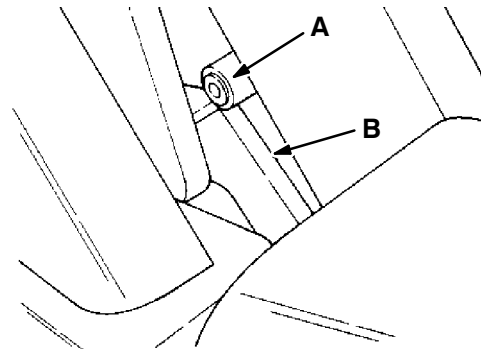

CAM FOLLOWER

01509

- A. Cam Follower**
- B. Main Frame**

To adjust the cam position, loosen the cam arm stop bolt, adjust the position and retighten. Use care when making adjustments. If the cam strikes the main frame at too low an angle, it may be damaged. If the cam strikes the main frame at too high an angle, the dust dump door will not close fully.

TOP HOPPER SEAL – LOW DUMP MODEL

The low dump model top hopper seal is located on the top edge of the main brush opening. It seals the top rear edge of the hopper. The seal should be inspected for wear or damage after every 100 hours of operation.

TO REPLACE TOP HOPPER SEAL

1. Empty the machine debris hopper.
2. Park the machine on a level surface and set the machine parking brake.

FOR SAFETY: Before Leaving Or Servicing Machine; Stop On Level Surface, Set Parking Brake, And Turn Off Machine And Remove Key.

3. Raise the hopper, engage the hopper support bar, and lower the hopper onto the hopper support bar.

! WARNING: Falling Hopper. Engage Hopper Support Bar Before Working Under Hopper.

4. Stop the engine.
5. Remove the hopper top seal retaining strip retaining bolts.
6. Remove the hopper top seal retaining strip and hopper top seal.

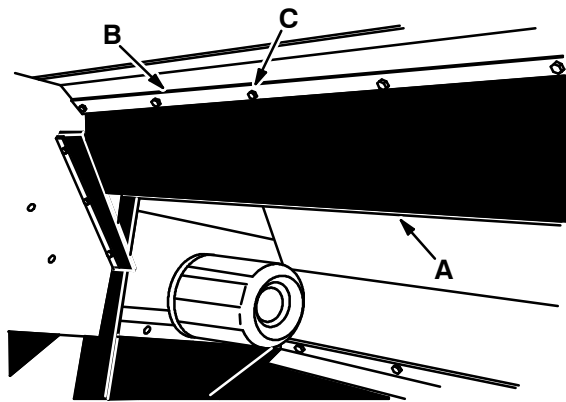

TOP HOPPER SEAL

06798

- A. Top Hopper Seal**
- B. Seal Retaining Strip**
- C. Retaining Bolt**

7. Thread the retaining strip mounting bolts through the retaining strip, the hopper top seal, and into the machine frame.
8. Tighten the mounting bolts.
9. Start the engine. Raise the hopper, lower the hopper support bar, and lower the hopper.
10. Stop the engine.

HINGED TOP HOPPER SEAL – MULTI-LEVEL DUMP MODEL

The hinged top hopper seal is located on the top of the rear hopper opening. It keeps debris in the hopper while the hopper is being raised before the hopper door is opened. The seal should be inspected for wear or damage after every 100 hours of operation.

TO REPLACE AND ADJUST HINGED TOP HOPPER SEAL

1. Empty the hopper.
2. Park the machine on a level surface and set the parking brake.

FOR SAFETY: Before Leaving Or Servicing Machine; Stop On Level Surface, Set Parking Brake, And Turn Off Machine And Remove Key.

3. Raise the hopper, engage the hopper support bar, and lower the hopper onto the hopper support bar.

! WARNING: Falling Hopper. Engage Hopper Support Bar Before Working Under Hopper.

4. Stop the engine.
5. Remove the stationary hinge bracket mounting bolts to remove the hinged top seal assembly.

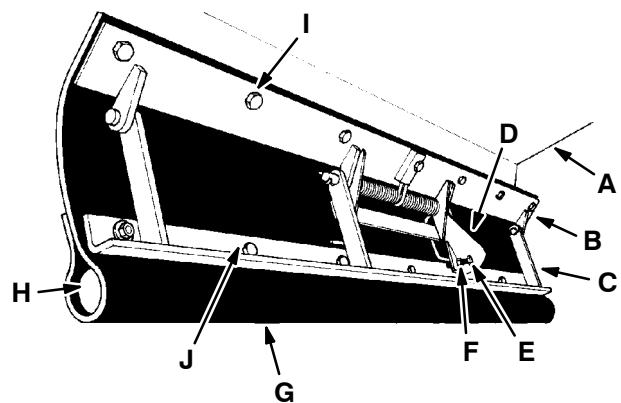

HINGED TOP HOPPER SEAL

01490

- A. Hopper**
- B. Stationary Hinge Bracket**
- C. Movable Hinge Bracket**
- D. Shell Cam**
- E. Adjustment Bolt**
- F. Jam Nut**
- G. Top Hopper Seal**
- H. Sponge Core**
- I. Stationary Hinge Bracket Mounting Bolt**
- J. Movable Hinge Bracket Mounting Bolt**

6. Remove the movable hinge bracket bolts to remove the top seal.

MAINTENANCE

7. Mount the new top seal with the sponge core on the movable hinge bracket.
8. Mount the new top seal and stationary hinge bracket to the hopper.
9. Start the engine, raise the hopper, disengage the hopper support bar, and lower the hopper.
10. Open the right brush door.
11. Remove the main brush as described in *TO REMOVE MAIN BRUSH*.
12. Looking through the right brush door opening, check to make sure approximately three-fourths of the top seal is making contact with the machine frame. If three-fourths of the seal is not making contact, raise the hopper, engage the hopper support bar, loosen the shell cam jam nut, and turn the adjustment bolt to the left to increase the amount of contact or to the right to decrease the amount of contact.

NOTE: If too much of the top hopper seal contacts the machine frame, the hopper may not be able to seat in the sweeping position, causing poor debris pickup.

Tighten the jam nut, raise the hopper, disengage the hopper support bar, lower the hopper and recheck the seal contact. Repeat the procedure as necessary.

HOPPER DOOR HINGE SEAL – MULTI-LEVEL DUMP MODEL

The multi-level dump hopper door hinge seal seals the area between the hopper door and the hopper. Check the seal for wear or damage after every 100 hours of operation.

TO REPLACE HOPPER DOOR HINGE SEAL

1. Empty the hopper.
2. Park the machine on a level surface and set the parking brake.

FOR SAFETY: Before Leaving Or Servicing Machine; Stop On Level Surface, Set Parking Brake, And Turn Off Machine And Remove Key.

3. Raise the hopper, engage the hopper support bar, and lower the hopper onto the hopper support bar.

! WARNING: Falling Hopper. Engage Hopper Support Bar Before Working Under Hopper.

4. Stop the engine.
5. Remove the two seal retainers and the old hinge seal.

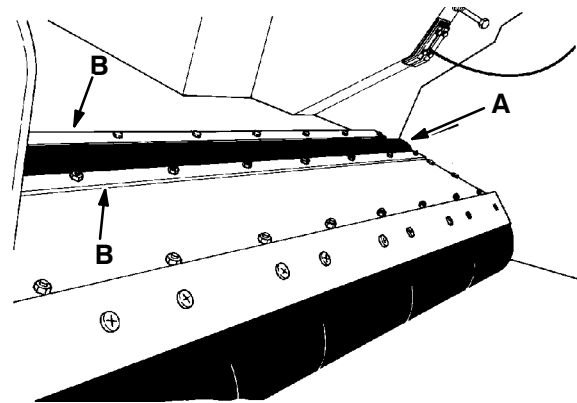

HOPPER DOOR HINGE SEAL

01487

A. Hinge Seal
B. Seal Retainer

6. Position the new seal between the hopper door and the hopper.
7. Secure the seal with the seal retainers and hardware.
8. Start the engine, raise the hopper, disengage the hopper support bar, and lower the hopper.
9. Stop the engine.

LATCHES

HOPPER COVER LATCH

The hopper cover latch should be lubricated with a dry lubricant after every 200 hours of operation. If the hopper cover does not close easily, or if the latch components are replaced, adjust the latch as described.

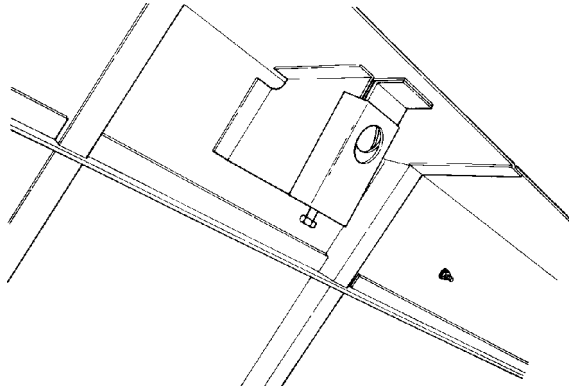

01458

HOPPER COVER LATCH

TO ADJUST HOPPER COVER LATCH

1. Stop the engine and set the machine parking brake.

FOR SAFETY: Before Leaving Or Servicing Machine; Stop On Level Surface, Set Parking Brake, And Turn Off Machine And Remove Key.

2. Push in the hopper cover latch release button and lift the hopper cover.
3. Unclip the hopper cover prop arm from its storage and position it in the hopper cover.
4. Lower the hopper cover onto the prop arm.

NOTE: All hopper cover seals must be in place before adjusting the latch.

5. Loosen the latch stud jam nut.
6. Thread the stud out of the hopper if the latch does not latch. Thread the stud into the hopper if the latch catches but is loose.
7. Tighten the jam nut and check the latch tightness. Readjust if necessary.

SIDE DOOR LATCHES

The side door latches need no regular maintenance. They should be adjusted whenever the door does not latch properly. Loosen the latch nuts, slide the latch in or out to adjust, and tighten the latch nuts.

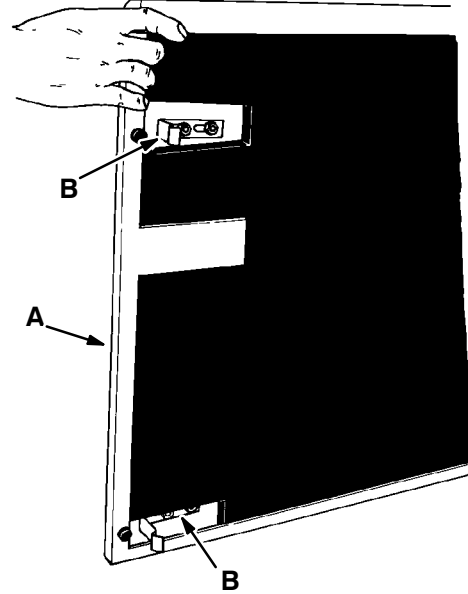

01492

SIDE DOOR LATCHES

- A. Side Door
- B. Latch

HOPPER INSPECTION DOOR LATCH

The hopper inspection door latches need no regular maintenance. They should be adjusted whenever the door does not latch properly. Loosen the latch nuts, slide the latch up or down to adjust, and tighten the latch nuts.

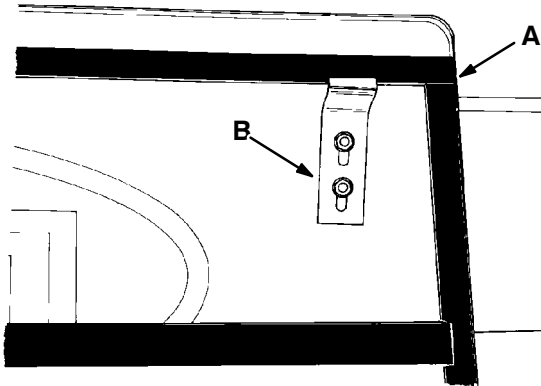

01493

HOPPER INSPECTION DOOR LATCH

- A. Hopper Inspection Door
- B. Latch

REAR ACCESS DOOR LATCH

The rear access door latch needs no regular maintenance. It should be adjusted whenever the door does not latch properly. Loosen the latch nuts, thread them in or out to move the latch tongue, and tighten the latch nuts.

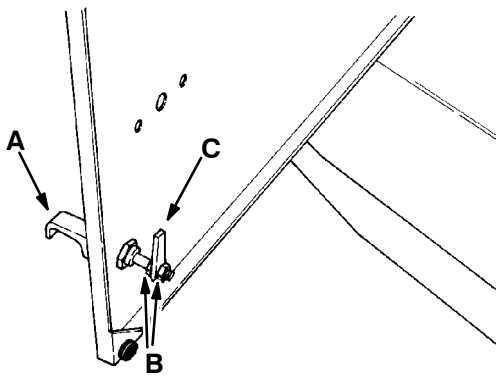

01494

REAR ACCESS DOOR LATCH

- A. Latch
- B. Nuts
- C. Latch Tongue

BRAKES AND TIRES

SERVICE BRAKES

The service brakes are hydraulically activated by a master brake cylinder. Check the master brake cylinder fluid level after every 400 hours of operation and add brake fluid as needed. The master brake cylinder is located at the front of the machine, behind the hopper.

If necessary, adjust the brake clevis on the master cylinder push rod so that the brake pedal is in a horizontal position when the cylinder push rod starts to engage the cylinder piston.

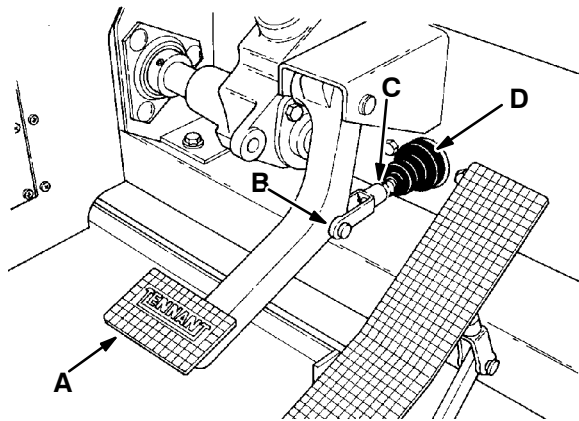

BRAKE PEDAL

01495

- A. Brake Pedal**
- B. Brake Clevis**
- C. Master Cylinder Push Rod**
- D. Push Rod Boot**

Brakes require bleeding whenever air enters the system, lowering the effective braking pressure. Air can enter when the master cylinder or wheel cylinders are serviced or if the fluid in the reservoir runs dry. Air can also enter through a leaky brake line or hose. Find the leaking line and replace it before bleeding the system.

Whenever handling brake fluid, do not get any on the brake pads, brake drums, or body paint. Brake pads will be permanently damaged, requiring replacement. Body paint can be damaged also unless you wipe the area with a clean cloth and wash it with soapy solution immediately.

1. Make sure that the brake fluid reservoir is full and that the vent in the cap is open.
2. Connect a plastic or rubber tube to the bleeder valve on the left front wheel. Suspend the other end of the tube in a jar or bottle filled with a few inches of brake fluid. During the remaining steps, keep this end submerged at all times and never let the level in the brake fluid reservoir drop below one half full.
3. Open the bleeder valve on the left front wheel about one turn. Have an assistant press the brake pedal slowly to the floor. As soon as the pedal is all the way down, close the bleeder valve and let the pedal up. Repeat this step as many times as necessary, until fluid, free of air bubbles, exits from the tube.
4. Bleed the right front wheel in the same manner as described in the steps above. Keep checking the brake fluid reservoir to be sure it doesn't run out of fluid.
5. When all wheels are bled, discard the brake fluid in the jar or bottle; never reuse such fluid.
6. Top up the brake fluid reservoir with clean fluid.

MAINTENANCE

PARKING BRAKES

The parking brakes are mechanically activated by the parking brake lever and two cables.

The parking brakes should be adjusted whenever the machine rolls after engaging the parking brake, or when it becomes very easy to engage the parking brake, and after every 50 hours of operation. The parking brake may be routinely tightened by turning the knurled knob on the end of the parking brake clockwise. If the knob adjustment is inadequate, fully loosen the knob, loosen the brake cable mounting nuts, thread the lower nuts closer to the end of the cable, and retighten the top nuts. Be sure to thread the nuts out the same number of turns. Adjust the parking brake enough to make the parking brake slightly resist being engaged.

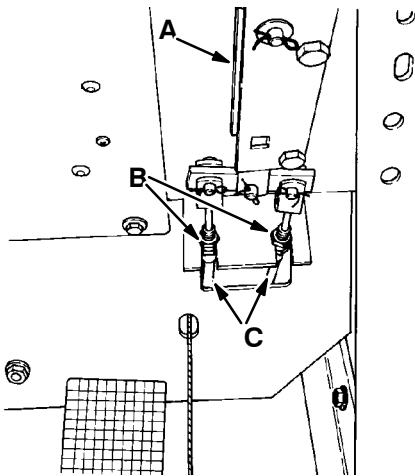

PARKING BRAKE

- A. Parking Brake**
- B. Cable Nut**
- C. Brake Cable**

TIRES

The front machine tires are solid and require no regular maintenance.

The standard rear machine tire on the low dump model is pneumatic. The proper tire pressure is 50 to 55 psi (345 to 380 kPa). Observe the tire daily to see if it appears to be low. Check the tire air pressure after every 50 hours of operation.

An optional Super Rib pneumatic tire is available. The proper tire air pressure is 50 to 55 psi (345 to 380 kPa). Check the tire air pressure after every 50 hours of operation.

An optional foam-filled or a solid rear tire is also available. No regular maintenance is required on either of these tires.

The rear machine tire on multi-level dump model is solid and requires no regular maintenance.

01496

OPTIONS

AIR FILTER OPTION

An air filter option is available on low dump and multi-level dump models.

The filter option is a heavy duty dry cartridge-type filter. The air filter element must be replaced whenever the air filter service indicator reads 20 in H₂O (5 kPa) and the "SERVICE WHEN RED" window is filled with red.

TO REPLACE AIR FILTER ELEMENT

1. Stop the engine and set the machine parking brake.

FOR SAFETY: Before Leaving Or Servicing Machine; Stop On Level Surface, Set Parking Brake, And Turn Off Machine And Remove Key.

2. Loosen the air filter clamp nuts.

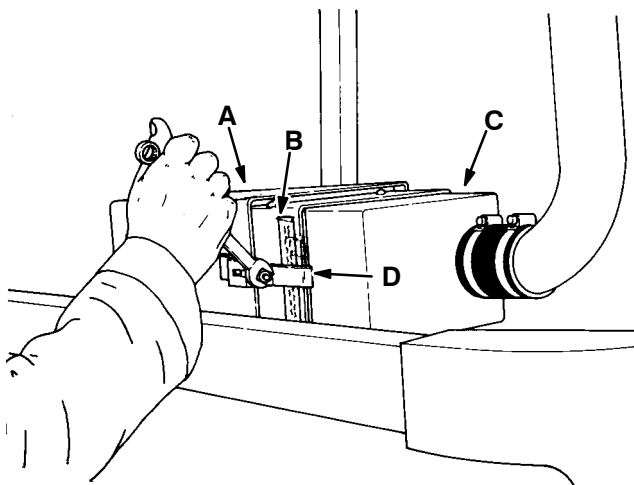

01468

DISASSEMBLING AIR FILTER

- A. Air Filter Housing**
- B. Pre-Cleaner**
- C. Pre-Cleaner Cover**
- D. Air Filter Clamp**

3. Remove the two air filter clamps and swing the pre-cleaner cover out of the way.
4. Remove the pre-cleaner.
5. Slide the air filter element out of the filter housing.

6. Slide a new filter element into the filter housing, rounded end first.

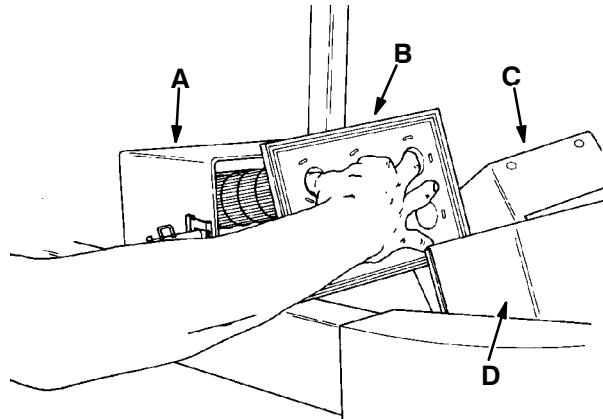

01469

INSTALLING AIR FILTER ELEMENT

- A. Filter Housing**
- B. Air Filter Element**
- C. Pre-cleaner**
- D. Pre-Cleaner Cover**

7. Position the pre-cleaner on the filter housing.
8. Position the pre-cleaner cover on the pre-cleaner with the air filter clamps.
9. Tighten the air filter clamp nuts to 75 in lb (8 Nm).

MAINTENANCE

SEVERE ENVIRONMENT AIR FILTER OPTION

This option is also part of the severe environment option package.

The filter option is a heavy duty filter. The air filter element must be replaced whenever the air filter service indicator reads 20 in H₂O (5 kPa) and the "SERVICE WHEN RED" window is filled with red.

TO REPLACE AIR FILTER ELEMENT

1. Stop the engine and set the machine parking brake.

FOR SAFETY: Before Leaving Or Servicing Machine; Stop On Level Surface, Set Parking Brake, And Turn Off Machine And Remove Key.

2. Loosen the air filter cover knob and pull the cover off the air cleaner.

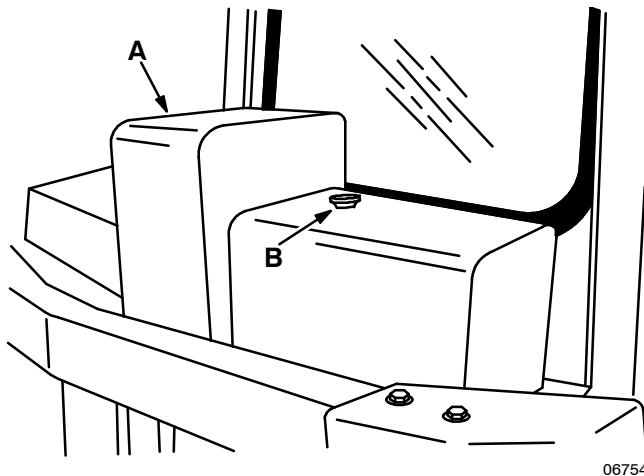

AIR FILTER COVER

- A. Air Filter Cover
- B. Cover Knob

3. Loosen the wing nut on the end cover and remove the end cover.

4. Loosen and remove the element wing nut. Pull out the air filter element.

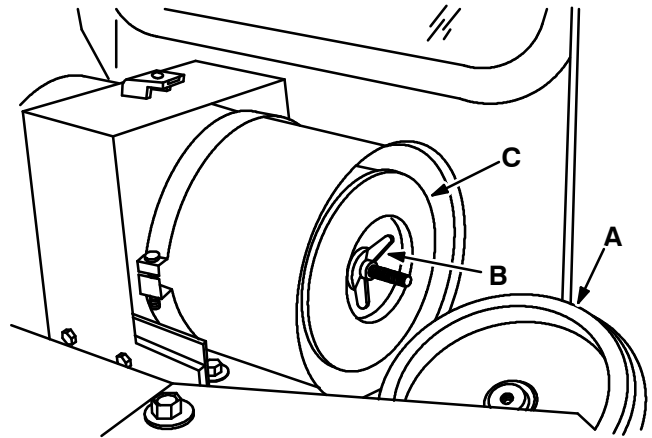

AIR FILTER ELEMENT

- A. End Cover
- B. Element Wing Nut
- C. Filter Element

5. Replace the inside secondary filter every third time the main filter element is replaced, or when if the main filter is damaged.
6. Install the air filter element finned end first. Be careful not to damage the fins. Make sure the element is seating evenly. Tighten the element wing nut.
7. Place the end cover back on the end of the air cleaner and tighten the wing nut.
8. Place the air cleaner cover over the air cleaner and tighten the cover knob.

OPERATING LIGHTS OPTION

The operating lights option includes headlights, taillights, turn signal lights, side brush spotlight; and on the multi-level dump model, a dumpster spotlight.

HEADLIGHT

The headlight mounting brackets have an adjustment screw and slot to allow the headlight beam to be directed closer or further away from the front of the machine. Loosen the adjustment screws, reposition the headlight, and retighten the screws to adjust the head light beam.

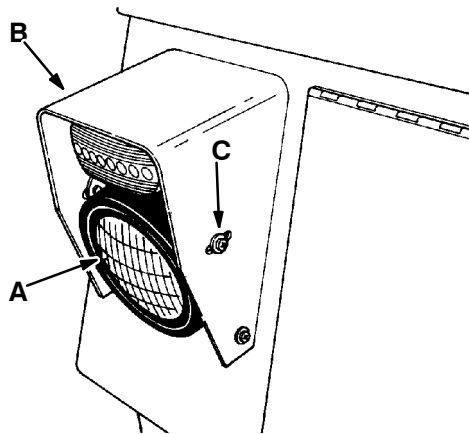

HEADLIGHT

01497

- A. Headlight**
- B. Headlight Mounting Bracket**
- C. Adjustment Screw and Slot**

SIDE BRUSH SPOTLIGHT

The side brush spotlight may be adjusted by loosening the angle adjustment nut or by loosening the mounting bolt. Retighten the bolts after adjusting the spotlight.

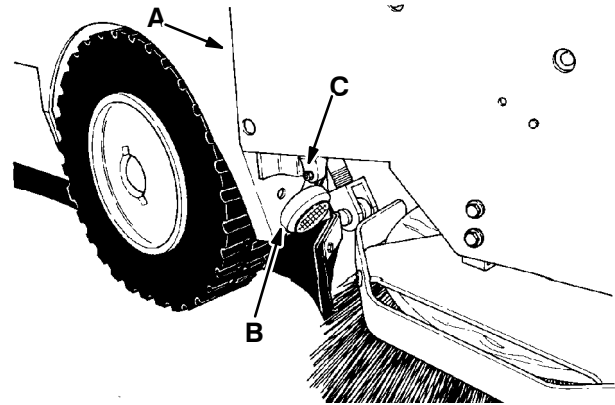

01498

SIDE BRUSH SPOTLIGHT

- A. Side Brush Bumper**
- B. Spotlight**
- C. Angle Adjustment Nut**

DUMPSTER SPOTLIGHT

On multi-level dump model, the dumpster spotlight may be adjusted by loosening the angle adjustment nut. Retighten the nut after adjusting the spotlight.

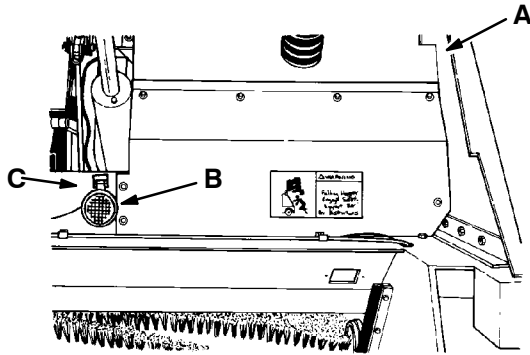

01462

DUMPSTER SPOTLIGHT

- A. Lintel**
- B. Spotlight**
- C. Adjustment Nut**

The dumpster spotlight is turned on and off by the hopper position switch.

DEBRIS DEFLECTOR SKIRTS OPTION

The debris deflector skirts are present on machines with the debris deflector skirts option. The skirts deflect light debris out of the way of the front tires into the path of the main brush. Check the debris deflector skirts for wear or damage daily.

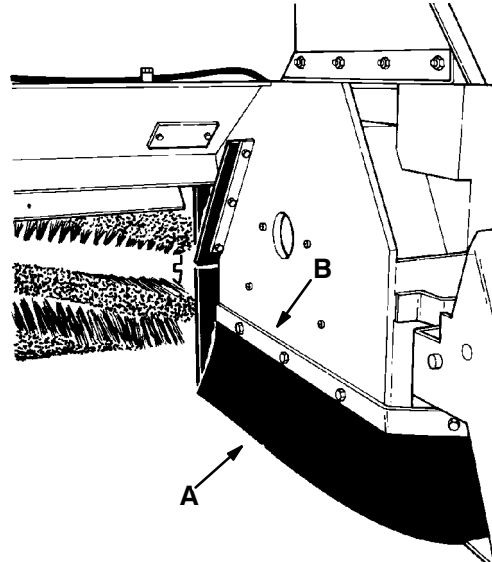

01491

LEFT SIDE DEBRIS DEFLECTOR

- A. Debris Deflector Skirt**
- B. Skirt Retainer**

SIDE BRUSH DUST CONTROL OPTION

The side brush dust control option helps control side brush dust in extremely dusty conditions. The option consists of a number of skirts which are positioned along the outside of the hopper and totally enclose the side brush. Check all of the skirts for wear or damage daily.

SECTION 4

CONTENTS

	Page
HARDWARE INFORMATION	4-3
STANDARD BOLT TORQUE CHART	4-3
METRIC BOLT TORQUE CHART	4-3
BOLT IDENTIFICATION	4-3
THREAD SEALANT AND LOCKING COMPOUNDS	4-3
HYDRAULIC FITTING INFORMATION	4-4
HYDRAULIC TAPERED PIPE FITTING (NPT) TORQUE CHART	4-4
HYDRAULIC TAPERED SEAT FITTING (JIC) TORQUE CHART	4-4
HYDRAULIC O-RING FITTING TORQUE CHART	4-4

HARDWARE INFORMATION

The following charts state standard plated hardware tightening ranges for normal assembly applications. Decrease the specified torque by 20% when using a thread lubricant. Do not substitute lower grade hardware for higher grade hardware. If higher grade hardware than specified is substituted, tighten only to the specified hardware torque value to avoid damaging the threads of the part being threaded into, as when threading into speed nuts or weldments.

STANDARD BOLT TORQUE CHART

Thread Size	SAE Grade 5 Torque ft lb (Nm)	SAE Grade 8 Torque ft lb (Nm)
0.25 in	7–10 (9–14)	10–13 (14–38)
0.31 in	15–20 (20–27)	20–26 (27–35)
0.38 in	27–35 (37–47)	36–47 (49–64)
0.44 in	43–56 (58–76)	53–76 (72–103)
0.50 in	65–85 (88–115)	89–116 (121–157)
0.62 in	130–170 (176–231)	117–265 (159–359)
0.75 in	215–280 (291–380)	313–407 (424–552)
1.00 in	500–650 (678–881)	757–984 (1026–1334)

NOTE: Decrease torque by 20% when using a thread lubricant.

METRIC BOLT TORQUE CHART

Thread Size	Class 8.8 Torque ft lb (Nm)	Class 10.9 Torque ft lb (Nm)
M4	2 (3)	3 (4)
M5	4 (5)	6 (8)
M6	7 (9)	10 (14)
M8	18 (24)	25 (34)
M10	32 (43)	47 (64)
M12	58 (79)	83 (112)
M14	94 (127)	133 (180)
M16	144 (195)	196 (265)
M20	260 (352)	336 (455)
M24	470 (637)	664 (900)

NOTE: Decrease torque by 20% when using a thread lubricant.

Exceptions to the above chart:

Main brush drive plug nut – 30 ft lb (40 Nm)
then tighten to next slot.

Brake unit to hub sockethead screw –
9 to 12 ft lb (12 to 16 Nm) with Loctite 242
blue.

APPENDIX

Front wheel nut – 10 to 12 ft lb (14 to 16 Nm)
while turning wheel, tighten to spec, then
backoff, retighten by hand till snug, then turn to
next slot.

Damper solenoid nut – 20 to 23 in lb
(2.5 to 3 Nm).

Pitman arm to steering column nut – 160 ft lb
(215 Nm).

Propelling motor shaft thin nylon lock nut –
7 to 10 ft lb (9 to 14 Nm).

Propelling motor adapter bolts – 16 to 21 ft lb
(21 to 28 Nm) with Loctite 242 blue on threads.
Use Loctite 515 sealant on the pilot fillet of the
motor and the adapter.

Rear wheel lug nuts – 95 to 110 ft lb
(129 to 150 Nm)

BOLT IDENTIFICATION

Identification Grade Marking	Specification and Grade
---------------------------------	----------------------------



SAE – Grade 5



SAE – Grade 8



ISO – Grade 8.8



ISO – Grade 10.9

01395

THREAD SEALANT AND LOCKING COMPOUNDS

Thread sealants and locking compounds may be
used on this machine. They include the following:

Loctite 515 sealant – gasket forming material.
TENNANT® Part No. 75567, 15 oz (440 ml)
cartridge.

Loctite 242 blue – medium strength thread
locking compound. TENNANT® Part No.
32676, 0.5 ml tube.

Loctite 271 red – high strength thread locking
compound. TENNANT® Part No. 19857, 0.5 ml
tube.

HYDRAULIC FITTING INFORMATION

HYDRAULIC TAPERED PIPE FITTING (NPT)
TORQUE CHART

NOTE: Ratings listed are when using teflon thread seal.

Size	Minimum Torque	Maximum Torque
1/4 NPT	10 ft lb (14 Nm)	30 ft lb (41 Nm)
1/2 NPT	25 ft lb (34 Nm)	50 ft lb (68 Nm)
3/4 NPT	50 ft lb (68 Nm)	100 ft lb (136 Nm)

HYDRAULIC TAPERED SEAT FITTING (JIC)
TORQUE CHART

Tube O.D. (in)	Thread Size	Maximum Torque
0.25	0.44-20	9 ft lb (12 Nm)
0.38	0.56-18	20 ft lb (27 Nm)
0.50	0.75-16	30 ft lb (41 Nm)
0.62	0.88-14	40 ft lb (54 Nm)
0.75	1.12-12	70 ft lb (95 Nm)
1.0	1.31-12	90 ft lb (122 Nm)

HYDRAULIC O-RING FITTING TORQUE CHART

Tube O.D.(in)	Thread Size	Minimum Torque	Maximum Torque
0.25	0.44-20	6 ft lb (8 Nm)	9 ft lb (12 Nm)
0.38	0.56-18	13 ft lb (18 Nm) *10 ft lb (14 Nm)	20 ft lb (27 Nm) 12 ft lb (16 Nm)
0.50	0.75-16	20 ft lb (27 Nm) *21 ft lb (28 Nm)	30 ft lb (41 Nm) 24 ft lb (33 Nm)
0.62	0.88-14	25 ft lb (34 Nm)	40 ft lb (54 Nm)
0.75	1.12-12	45 ft lb (61 Nm)	70 ft lb (95 Nm)
1.0	1.31-12	60 ft lb (81 Nm)	90 ft lb (122 Nm)

NOTE: Do not use sealant on o-ring threads.

*Aluminum bodied components