

New Equipment Warranty

Limited Warranty

Caliber Equipment Inc. warrants new equipment against defects in material and workmanship under normal use and service to the original purchaser. Any statutory implied warranties, including any warranty of merchantability or fitness for a particular purpose, are expressly limited to the duration of this written warranty. **Caliber Equipment Inc.** will not be liable for any other damages, including but not limited to indirect or special consequential damages arising out of or in connection with the furnishing, performance, use or inability to use the machine. This remedy shall be the exclusive remedy of the purchaser. The warranty period is subject to the conditions stated below.

5 Years - Motor and Gearbox. 1 Year- Service Labor

Caliber Equipment Inc. warrants electric motors and transmission gearboxes on this floor machines to be free from defects in material and workmanship, under normal use and service for five (5) years to the original purchaser. Parts replaced or repaired under this warranty are warranted for the remainder of the original warranty period. Service labor charges are covered for one (1) year from the date of purchase, when performed by an authorized-service provider. Freight charges to and from this service providers will be covered for 90 days from the purchase date. After this 90 day period, these freight charges will be paid by the equipment owner. Travel expenses are not covered.

Wear Items on All Machines

Critical Wear Items - bearings, capacitors, clutches, pulleys, rectifiers, relays, switches, wheels, tires and casters are warranted for manufacturing defects for one (1) year from the purchase date.

Normal Wear Items - belts, brushes, bumpers, carbon brushes, cords, finishes, squeegees, actuating cables, and gaskets are warranted for manufacturing defects for ninety (90) days from the purchase date.

All warranties of motors and associated components will be voided; if the machine is used as a floor sander; if the machine is serviced by anyone other than a Mercury-authorized service provider; if the machine is mechanically modified; or if the machine is misused or abused.

The warranty starts on the purchase date by the original purchaser from an authorized Mercury Floor Machines, Inc. distributor, subject to proof of purchase. The Machine Registration Card must be completed and returned immediately at the time of purchase. If proof of purchase cannot be identified, the warranty start date is 90 days after the date of sale to an authorized Mercury Floor Machines, Inc. Distributor.

Caliber
Equipment, Inc.

11482 Fox Cross Rd.
Ashland, VA 23005
Toll free# 888-550-0945
Local# 804-798-4333
Fax# 804-798-4335

Caliber
Equipment, Inc.

C-20LS

1.5 HP / 175 RPM / 20"
Heavy Duty Floor Machines

C-20-LS Design and Engineering

- Powered by a precision-balanced, heavy-duty, 1.5 HP, 66-frame motor for easiest operation.
- The triple-planetary high torque transmission handles the most demanding jobs.
- All metal, 20" reinforced bell housing apron.
- Scrub with a 19" rotary brush or a 20" pad and a pad driver with riser. Easy brush mounting with a "B"/ "92" style drive plug and clutch plate.
- All metal chassis gives extra weight for fastest results. Polished finish looks newer, longer.
- Safety enhanced interlock switch on the handle leaves both hands conveniently in control.
- Safety-enhanced, non-conductive dual triggers on the handle eliminate shock potential.
- 48" tall handle is fully adjustable to be comfortable for all operators.
- Includes a 50-foot safety power cable.
- Motor plugs into cable at the base of the handle for easy maintenance.
- Non-marking super-thick bumper protects walls and baseboards.
- Non-marking retractable 6" wheels make transport easy.
- 5-year warranty on motor, transmission and chassis.

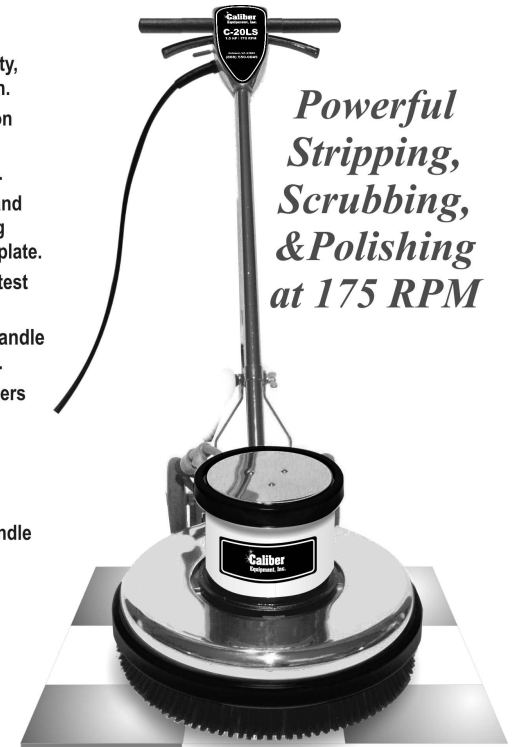

SPECIFICATIONS

Model No.	C-20LS
Apron	20"
Motor Type	1.5 HP A/C 2 capacitors, 13-15 amp draw
Brush Speed	175 RPM
Brush Size	19" Brush, 20" Pad Driver w Riser.
Brush Drive	"92" style / "B" style drive plug and clutch plate
Weight	105 lbs.
Chassis	Polished aluminum
Power Cord	50 foot safety yellow 14/3 Ga.
Wheels	6" non-marking
Warranty	5 years motor, transmission, and chassis

©2009. Caliber Equipment Inc.

1.0 Safe Operating Conditions

READ THIS MANUAL BEFORE USING THIS FLOOR MACHINE.
KNOW THE PROPER OPERATION, CORRECT APPLICATIONS
AND THE LIMITATIONS OF THIS EQUIPMENT **BEFORE** USE.

Reduce the risk of fire, electric shock, or injury:

- This floor machine is designed for indoor use only. Do not use outdoors. Do not expose to rain.
- Do not wash motor with flowing water. If motor gets wet, seek authorized service.
- Keep the vents on this air-cooled motor free of debris. Do not operate with the motor covered or with vents blocked.
- Never operate this floor machine near flammable dusts, liquids or vapors. Never use flammable solvents as a cleaning agent. Engine sparks and operating heat can cause a fire.
- Never handle electrical equipment with wet hands. Never operate this floor machine with bare feet.
- Unplug the floor machine when not in use and when servicing the equipment. To unplug, grasp the plug, not the cord.
- Do not operate a floor machine with damaged handle controls, cord, or plug. If the equipment is not performing properly, seek repair from a qualified service supplier.
- This floor machine is constructed with electrical grounding at the plug. Operate only when connected to a properly grounded outlet. See section 1.2 for grounding details.
- Prevent electrical cord abuse. Do not close a door upon the cord, drive equipment over it, or run the floor machine over it. Do not expose the cord to hot surfaces. Do not lift, pull or carry this floor machine by the cord.
- Never operate the floor machine over sharp objects that can be thrown out and harm the operator and damage the floor. Sweep hard-floors before scrubbing or buffing. Vacuum clean carpets before shampooing or bonnet cleaning.
- Train your staff in the proper use of this floor machine.

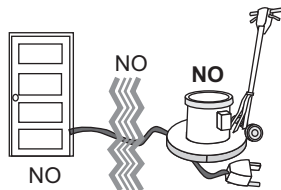
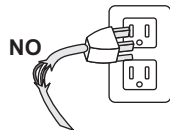

5.2 Scrubbing Brush Filaments

Scrubbing brushes are available with a range of bristle types - - from the softest for the highest gloss floors, to the most aggressive for the heaviest soils. Match your brush to the floor as you match a detergent with the soils.

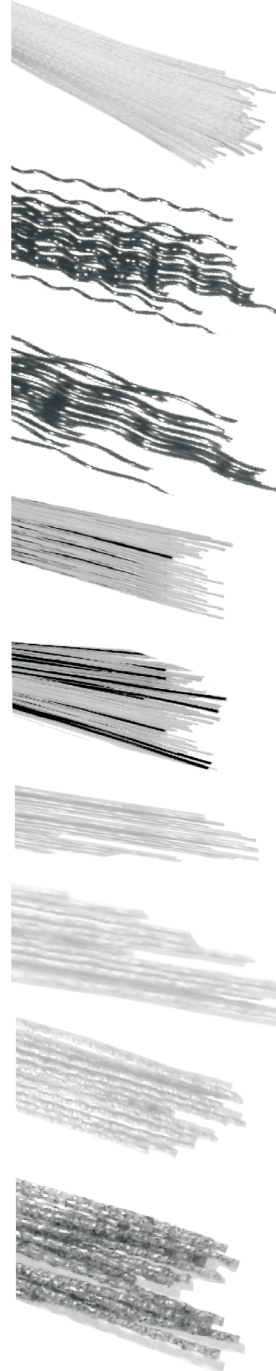

Nylon is used for general scrubbing. Because Nylon softens when wet, it is great for gentle scrubbing, mopping, and polishing of decorative floors. Nylon will not scratch tile, terrazzo or coated surfaces. Nylon brushes are durable and long lasting.

Polypropylene is a common choice for general purpose scrubbing and works well on both concrete and on coated floors. Polypropylene brushes typically cost less than nylon, but do not last as long.

Non-Scuff Poly is a finer diameter (0.015-0.018") filament used for lighter duty scrubbing conditions and on waxed or finished floors.

Bassine is a soft natural fiber. The end of the bristle splits or "flags" to build a polishing surface.

Union Mix is a mixture of Bassine and Tampico (another natural fiber). The mixture is stiffer than bassine alone and is used by more traditional cleaners for scrubbing. Often replaced by poly.

Soft Abrasive Bristle is a 0.018" Nylon filament extruded with a 500 grade grit. For gentle scrubbing. *As aggressive as a white scrub pad.*

Daily Abrasive Bristle is a 0.035" Nylon filament with 180 grade grit. For daily scrubbing of resilient tile and finished floors. *As aggressive as a red scrub pad.*

Stripper Abrasive Bristle is a 0.022" Nylon filament with 120 grade grit. For aggressive scrubbing and light stripping of resilient floors, terrazzo, and concrete. *As aggressive as a blue scrub pad.*

Heavy Duty Stripper Abrasive Bristle is a 0.050" Nylon filament with 80 grade grit. For very aggressive scrubbing and stripping of concrete, brick, and quarry tile. *As aggressive as a black scrub / strip pad.*

2.0 Mount the Handle

This floor machine is shipped from the factory with the handle unattached. You will need two 7/16" wrenches to complete the assembly.

Remove the handle and mounting hardware from its carton. Bolts, nuts, washers and the locking lever assembly are in the plastic bag attached to the handle.

1. Mount the handle on the chassis.

Align the handle with the yoke (1) over the mount (2) on the buffer chassis. The power cord will be facing the motor. Place a flat washer (4) on a 3" bolt (3), then place the bolt through the holes in the yoke and the mount. Place another washer on the bolt and secure with the locking nut (5).

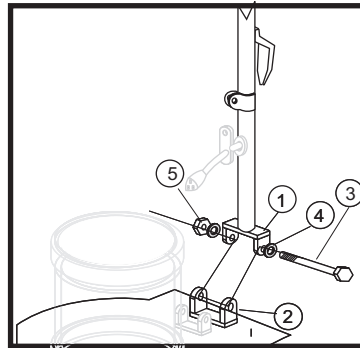

2. Connect the support braces to the handle.

Tip the handle "up". The handle mounting collar (7) is designed to slide freely up and down the handle tube, allowing the handle to be adjusted for the comfortable operation of all users. Line up the mounting collar with the upper holes in the two bent handle braces (6).

- Place the spacer with the rectangular hole (12) onto the locking lever shaft (11). The spacer must fit completely onto the rectangular neck of the lever shaft.
- Insert the shaft through the hole in the left handle brace (6), mounting collar (7), and right handle brace (8).
- Place a spacer (9) on the shaft.
- Place the split washer (10) on the shaft.
- Place the locking wing nut (13) on the shaft.
- Tighten and adjust the wing nut. When correctly installed, the collar slides easily when the cam-engineered locking lever is "up", but is firmly fixed when the lever is "down".

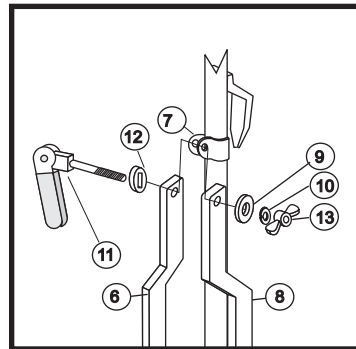

3.2 Transport

To transport this floor machine from the janitor's closet to the work area:

- Lock the handle in the "up" position. Wind the cord around the handles and the bottom cord hook.
- Tip the machine back onto the transport wheels. Push or pull the machine by the handle, not by the cord or any other part of the machine. Travel carefully.

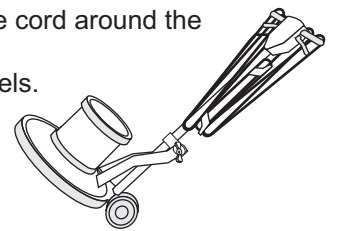

4.0 Troubleshooting

Never operate this floor machine when the equipment is not performing as expected or when any part is visibly damaged. The cause and solution for some basic problems are described below. When repair is needed, take the equipment to an authorized repair service center.

4.1 Floor machine will not run

- Circuit breaker tripped in building. **Check and reset.**
- Equipment unplugged. **Check plug at wall and at machine base. Plug in.**
- Power cord failure. **Test with a working power cord. Lock the handle up and tip the motor back. Unplug the cord at the motor and plug the motor into your working power cord. IMPORTANT! THIS IS JUST FOR TESTING. When you do this, you have removed the safety handle controls from the circuit and you are sending power directly to the motor. If the motor now spins, the problem is in the cord or the handle assembly. Seek authorized repair service.**
- If the motor still does not spin, the problem is either in the male connection at the motor base or in the motor. **Seek authorized repair service.**
- Motor sparks or smokes. **Seek authorized repair service.**

4.2 Electrical shock to operator

- Equipment wiring failure or electrical short in the machine. **Seek authorized service.**
- Poor grounding or no grounding. **Test the outlet with a ground fault interrupter. Retain a certified electrician to inspect and repair grounding. NEVER clip off the ground plug on your cord.**
- Repeated circuit breaking. **High amp draw and circuit breaking can be an electrical or mechanical problem. Seek authorized repair service.**

4.3 High Vibration

- Pad not centered. **Tip machine back and re-center the pad.**
- Unevenly wear or warp to pad or brushes. **Replace.**
- Machine chassis damaged by dropping. **Replace.**

5.0 Brush Construction

Your new floor machine provides reliable, efficient, safe power to your scrubbing brush. To get the best results, you need to use a brush of the best design and construction.

Your floor machine is built with a “B” style **drive plug (1)**. The height and width of the ears on the plug will match a “B”-style or a “Universal” **clutch plate (2)** mounted on the brush block.

The **brush block (3)** is constructed of molded plastic or thick plywood. **Use a brush with a block diameter 2” less than your machine apron size.**

The **bristle material (4)** that actually does the scrubbing is typically 1-1/2” to 2” long. Holes are drilled in the block and bundles of bristles are folded in half, forced into the hole and stapled in place (staple-set).

When the bristles wear down to less than 1/2” long, they have little flexibility and it’s time to replace. Bristle materials are described on page 11.

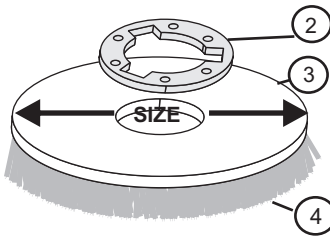
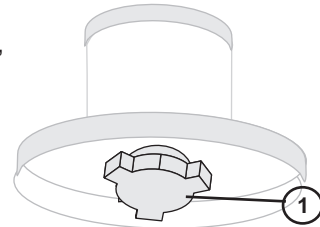

5.1 Pad Driver Construction

If you scrub or polish with a **non-woven pad**, use a **pad driver** to connect the pad to the machine.

The **brush block (3)** is constructed of molded plastic, fit with shorter, stiffer, **pad-holding bristles (5)** or “velcro-like” **pad-holding hooks (6)** and use a **riser (7)** to create extra clearance between the block and the machine apron. With this construction **use a pad driver with block diameter 1” less than your machine apron size.**

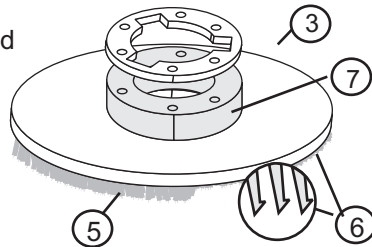

Machine Apron Size	20”
Pad Driver - with 3/4” Riser	20”
Brush - with NO RISER	19”

1.1 Electric Power

This floor machine operates on a 15 amp nominal 115V, 60 HZ, A.C. power circuit. (Motors may be custom wired at the factory for 220 V, 50 Hz international operation.) The amp, hertz, and voltage ratings are listed on the motor spec label found on each machine. Using voltages above or below those indicated on the spec label will damage the motor. Always check your local voltage requirements.

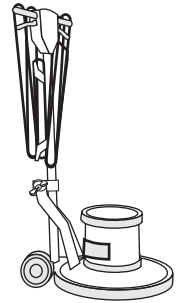

1.2 Grounding Instruction

This floor machine must be **grounded** while in use to protect the operator from electrical shock. This floor machine is built with a 3-wire cord and a 3-prong grounding type plug (Figure 1) to fit the properly grounded receptacle.

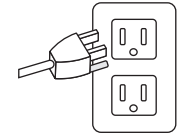

Figure 1

Before using this floor machine, make sure a properly grounded, 3-hole electrical outlet is available. If not, as in some older facilities, use an adapter for connecting a 3-prong plug to a 2-prong receptacle (Figure 2) to ground to the outlet chassis.

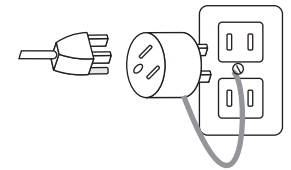

Figure 2

IMPORTANT!! This adaptor may not be used in Canada.

IMPORTANT!! Never cut off the grounding prong for use in a 2-prong outlet. By doing so, you have cut off your protection from electrical shock.

Never assume that all 3-hole outlets are properly grounded. Never assume that an adaptor connection (as in Figure 2) is properly grounded. Check the outlet with a **ground fault interrupter device** which quickly indicates if a ground is connected. Correct a faulty grounding before proceeding.

1.3 Extension Cords

This floor machine is shipped with a 50 foot (15 M) long safety cord which plugs directly into an approved outlet. The use of an extension cord is not recommended.

3.0 Operating Tips

- For indoor use only.
- Sweep abrasive soils before scrubbing.
- While the brush or pad driver is spinning, keep the floor machine moving to avoid “donut” burns on the floor.
- To start operation:
 - Unlock the handle by raising the locking lever.
 - Lower the handle to a comfortable position, typically waist height.
 - Relock the handle by pushing the lever down.
- **NEVER OPERATE THE MACHINE WITH THE HANDLE UNLOCKED.**
- This floor machine has a high torque motor. Hold the machine firmly with both hands when starting up.
- Push the red safety interlock switch forward to unlock the dual triggers.
- Squeeze the dual triggers to release power to the motor. Once power is on, either trigger will keep power to the motor.
- To stop the floor machine, release both triggers.
- The spinning brush helps move the floor machine. (Lift the handle slightly to work to the right. Push the handle down slightly to work to the left.)

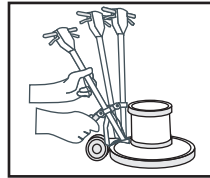

SET HANDLE HEIGHT

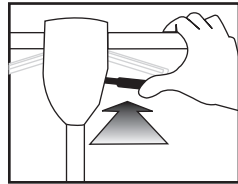

PUSH LOCK FORWARD

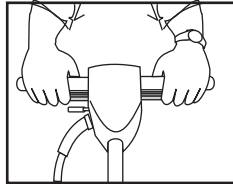

SQUEEZE BOTH TRIGGERS

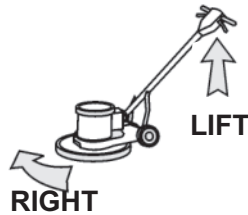

3.1 To store your machine

- Lock the handle in the “up” position. Tilt the machine back and remove the pad driver or brush.
- Wind the cord around the handles and the bottom cord hook.
- Wash brushes or pads and hang to dry.
- Never store machine standing on the brush.
- Inspect and maintain equipment on a regular schedule for best results.
- ✓ Check and clean pads after each operation. Remove soil and chemical buildup. Replace worn or damaged pads.
- ✓ Check the triggers and switches for proper operation.
- ✓ Repair or replace damaged skirts and bumpers.
- ✓ Use air pressure or vacuum to remove dust and debris from the motor vents.

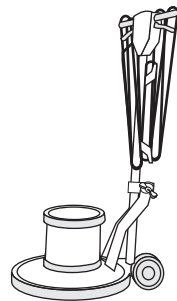
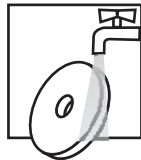

2.1 Attach the Power Cord

The triple-wire grounded power cord has been factory-installed into the handle tube. Plug the male connector (9) coming out of the motor housing into the female connector (10) coming out of the end of the handle tube.

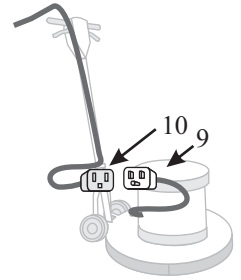

Now, plug the end of the 50 foot cord into a grounded power outlet. Squeeze the triggers on the handle and check for power to the motor.

2.2 Install the Brush or Pad Driver

A brush or pad driver mounts onto your floor machine with a “B” style Universal clutch plate.

Lock the machine handle in the “up” position and tip the floor machine back fully.

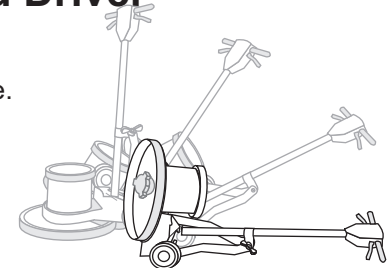

Slide the brush or pad driver clutch plate (11) over the drive plug (12).

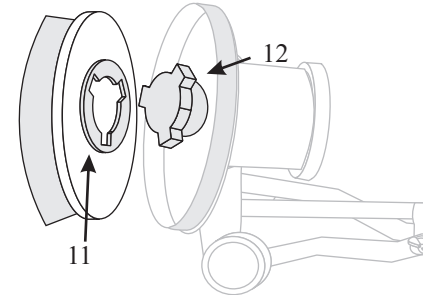

Quickly spin the brush counter-clockwise to lock the brush onto the drive plug.

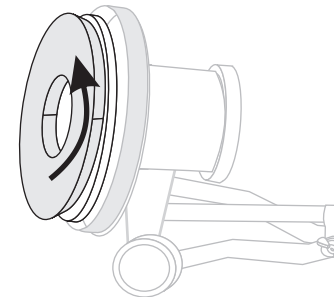

Now, lower the machine back onto the brush. You're ready to go to work.

Caliber
Equipment, Inc.
C-20LS
20" / 1500 RPM

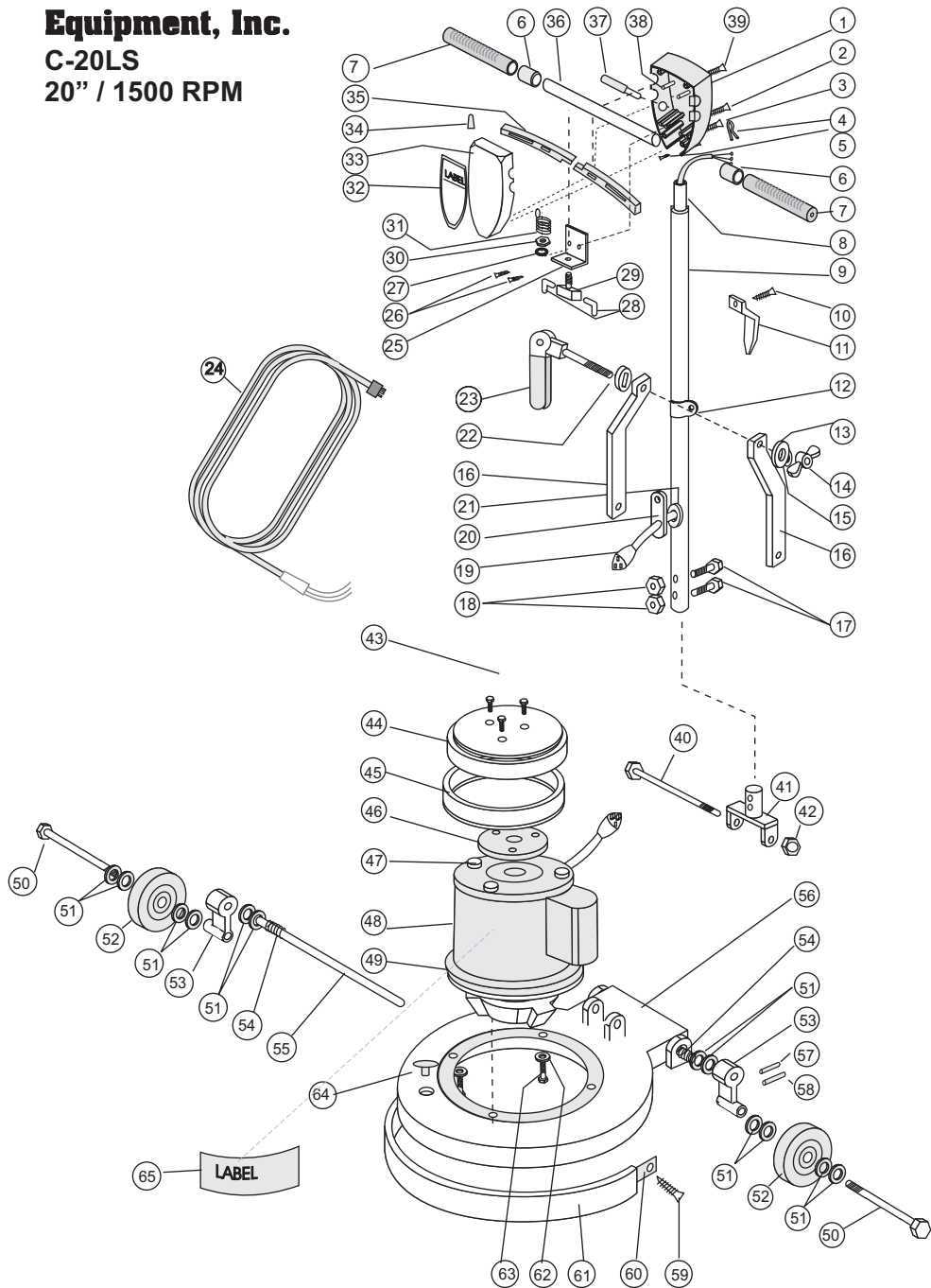

ITEM	DESCRIPTION	PART #	#REQUIRED
1	Switch Box Back	A-104	1
2	Handle Tube Screw	B-23	2
3	Switch Box Closing Screw	B-21	4
4	Strain Relief Clip	M-213	1
5	Ground Wire Screw	B-68	2
6	Rubber Spacer	M-218 Y	2
7	Hand Grip	M-218	2
8	Handle Tube Insert	M-247	1
9	Handle Tube Assembly	M-206	1
10	Cable Hook Screw	B-2	2
11	Cable Hook	A-164	1
12	Sliding Collar	A-111	1
13	Oval Hole Cam Washer	B-37	1
14	Cam Lock Wing Nut	B-25	1
15	Cam Split Washer	B-39	1
16	Bent Brace	M-216	2
17	Yoke Bolt	B-18A	2
18	Yoke Nut	B-19	2
19	Handle Tube Cable	G-16	1
20	Black Rubber Cable Connector	M-249	1
21	Cable Grommet	B-63	1
22	Rectangular Hole Cam Washer	B-67	1
23	Complete Cam Assembly	CCA	1
24	50 Foot Cable 14/3 Yellow	G-14-50-Y	1
25	Switch Mounting Plate	G-30-B	1
26	Switch Plate Screw	B-1	2
27	Int. Tooth Lock Washer (For Switch)	B-35	1
28	Insulated Flag Wire Connector	G-48	2
29	On-Off Switch And Plate Assembly	G-30-AB	1
30	Lock Washer	B-33	1
31	Trigger Return Spring	G-30-CT057	1
32	Label For Switch Box	CALL FOR #	1
33	Switch Box Front	A-103	1
34	Wire Connector	G-47	1
35	Trigger	A-105	2
36	16" Crossbar	M-211-A	1
37	Safety Interlock Assembly	SIA-1	1
38	Trigger Pin	B-70	2
39	Crossbar Screw	B-22	2
40	Yoke Bolt	B-14	1
41	Yoke	A-1001	1
42	Acorn Nut For Yoke Bolt	B-10	1
43	Drip Cap Mounting Screw	B-151	3
44	66 Frame Drip Cap Cover	M-242	1
45	66 Frame Drip Cap Cover Bumper	M-239	1
46	Cork Drip Cap Gasket	M-248	1
47	Split Washer	B-32	4
48	Motor 66 Frame 1.5 HP With Gearbox, 115V	MOTOR 1.5 HP / GB	1
49	Gear Box, 11:1, Triple Planetary	GB96008	1
50	Wheel Axel Bolt	B-15, BDP	2
51	Spring Washer	B-51	12
52	6" Wheel	M-245	2
53	Wheel Carriage	A-117	2
54	Spring	B-30	2
55	9" Axel	M-217	1
56	Base Casting 20"	A-129	1
57	Axel Pin	B-45	2
58	Wheel Axel Pin	B-46	2
59	Bumper Screw	B-68	2
61C	Bumper 20"	M-232-21	1
62	1/4" Medium Split Washer	B-32	3
63	Cap Screw	B-31	3
64	Scrubber Plug	B-50	1
65	Label for Motor	CALL FOR #	1

(6) Caliber C-20LS 175 RPM Floor Machine

Caliber C-20LS 175 RPM Floor Machine (7)