

275 Burnisher

Model 275

Operator Manual *275 Rider Burnisher*

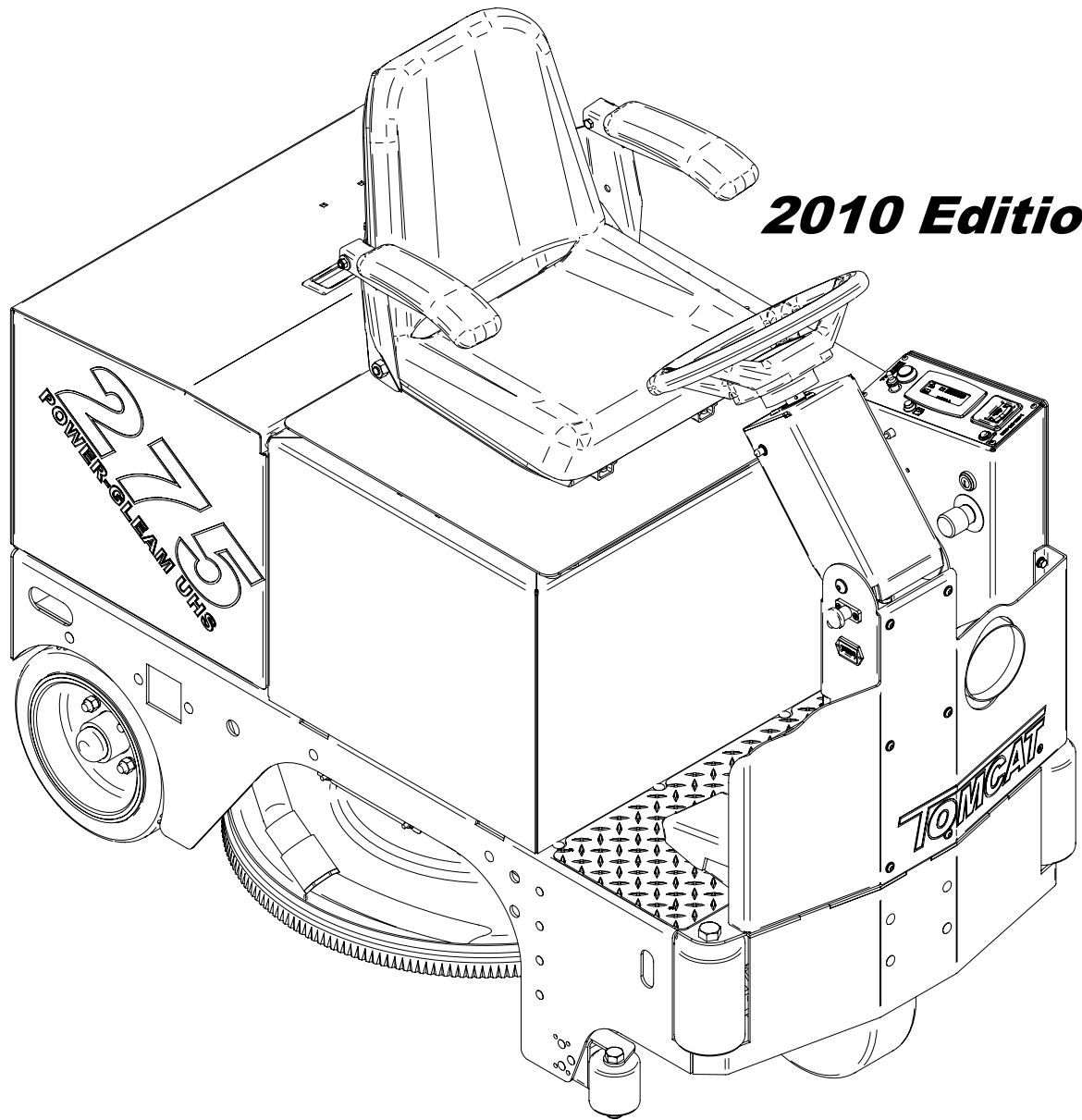

2010 Edition: 1

R.P.S. Corporation
P.O. Box 241
Racine, Wisconsin 53401

Phone: 1-800-450-9824
Fax: 1-866-632-6961

How to use this manual

This manual contains the following sections:

- **HOW TO USE THIS MANUAL**
- **SAFETY**
- **OPERATIONS**
- **MAINTENANCE**
- **PARTS LIST**

The **HOW TO USE THIS MANUAL** section will tell you how to find important information for ordering the correct replacement parts.

Parts may be ordered from authorized dealers. When placing an order for parts, the machine model and serial number are important.

Refer to **MACHINE INFORMATION** on page one of this manual, which is filled out during the installation of your machine.

The serial number of your machine is located on the lower half of steering tower of the machine. (See Picture Below)

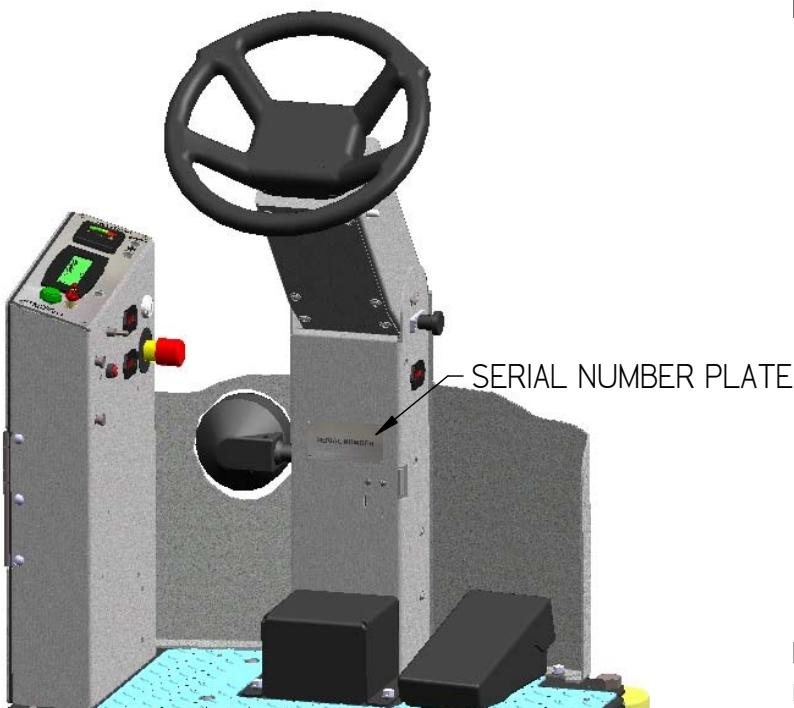

The **SAFETY** section contains important information regarding hazard or unsafe practices of the machine.

Levels of hazards are identified that could result in product or personal injury, or severe injury resulting in death.

The **OPERATIONS** section is to familiarize the operator with the operation and function of the machine.

The **MAINTENANCE** section contains preventative maintenance information to keep the machine and its components in good working condition. They are listed in this general order:

- Batteries
- Burnising Pads
- Cleaning Filter
- Service Schedule
- Machine Trouble shooting

The **PARTS LIST** section contains assembled parts illustrations and corresponding parts list. The parts lists include the following columns of information:

- **ITEM** - Refers to the reference number on the parts illustration.
- **PART NO.** - Lists the part number for the part.
- **QTY** - Lists the quantity of the part used in that area of the machine.
- **DESCRIPTION** - Is a brief description of the part.
- **COMMENTS** - For information not noted by the other columns.

NOTE: If a service or option kit is installed on your machine, be sure to keep the **KIT INSTRUCTIONS** which came with the kit. It contains replacement part numbers needed for ordering future parts.

STANDARD WARRANTY POLICY (RPS Corporation)

RPS Corporation warrants its machines, parts and accessories to be free of manufacturer's defects for the periods specified below. Warranty will be granted at the sole discretion of RPS Corporation and is subject to final claim and parts review by R.P.S. Corporation and its vendors. This policy is effective January 1, 2010 and is subject to change on production units at a future date.

COVERAGE, EXCLUSIONS AND LIMITATIONS:

Coverage:	All Models sold (Sweepers, Scrubbers, Burnishers)
Parts:	36 months / 1,500 hours on "Power On" hour meter
Labor:	12 months
Travel:	3 months (150 mile maximum)
Poly Tanks:	7 Years
OEM Parts:	3 months
Validity:	Fully completed Machine Delivery Form (online or fax) is on record at RPS.
Limitation:	Warranty will begin on date of machine installation to end-user or 6 months after shipment from RPS Corp to the distributor if unsold at that time.

This warranty includes all parts on the machine except normal wear parts. Some of these exceptions are:

1. Any Brooms, Brushes, Pads or Pad Drivers including Center Clip Retainers
 2. Floor Seals, Wipers, Splash Curtains, Squeegees or Gaskets.
 3. Filters, Dust Collection Bags or Screens
 4. The safety pins design to fail in shear, which are a fail-safe device
 5. Belts, Hoses or Tubing.
 6. Caster Wheels, Tires or internal tire tubes.
 7. Vacuum motors with evidence of water/foam passage or more than 450 hours
 8. Lights (Strobe, Headlights or bulbs).
 9. The Batteries (see below).
- ❖ **NOT COVERED:** Routine maintenance, adjustments or parts damaged from abuse, neglect, improper use of the machine, or lack of scheduled "daily, weekly, monthly" maintenance in accordance with our published PM Sheets.

POLY TANKS: 7 Years Coverage against leakage due to manufacturer's defect in materials or workmanship. **NOTE:** Freight coverage for 3-Years under the parts section of warranty.

BATTERIES: Warranted through battery manufacturer for **One (1) Year** (prorated) from the date of delivery. The battery manufacturer approves or denies the warranty coverage after analysis. We rely on solely on their review. **NOTE NOT COVERED:** Damage from lack of water, failure to use OEM charger, or non-distilled water.

Table of contents

Machine information form	Page 1		
Warranty registration form	Page 2		
Machine specifications	Page 3		
Common wear parts	Page 4		
Safety messages	Page 5		
!!Safety precautions!!	Page 6		
Machine controls and features	Page 7		
Controls and functions	Page 8		
Machine preparation	Page 9		
Machine setup	Page 10		
Operation	Page 11		
Pre-burnishing check list	Page 11		
One pass burnishing	Page 11		
Charging batteries	Page 12		
Maintenance	Page 13		
Preventative maintenance records	Page 14-16		
LCD screen menu display	Page 17		
Troubleshooting central command	Page 18-19		
Troubleshooting	Page 20-21		
Machine parts section	Page 22-40		
		<u>Machine Parts Illustration</u>	
		Front wall	Pages 23-24
		Front wheel drive	Pages 25-28
		Filter door and Rear Hood Hinges	Pages 29-30
		Rear axle mount	Pages 31-32
		Burnisher Deck	Pages 33-36
		Actuator Pivot	Pages 37-38
		Steering Upright	Pages 39-40
		Central Command	Pages 41-42
		Machine Top Components	Pages 43-44
		Batteries and Covers	Pages 45-46

Machine information

Please fill this area out at the time of installation for future reference.

Model number _____

Serial number: _____

Installation date: _____

Installing dealer: _____

Dealer contact: _____

Address: _____

City, state, zip: _____

Phone number: _____

This operator and parts manual should be considered a permanent part of the unit and should remain with the unit at all times. This operator and parts manual covers all the tomcat 275 Series burnishers. You may find descriptions and features that are not on your particular model. The information and specification included in this publication were in effect at the time of printing. R.P.S. Corporation reserves the right to make changes without notice incurring any obligation.

To register for warranty, fax your warranty registration form today!

Installing Dealer: _____ Installed By: _____

Location: (City, State): _____ Install Date: _____

End-User Company Name _____ End-User Contact: _____

Address: _____ City/State: _____ Zip _____

Phone: _____ Fax: _____ Email: _____

Model: _____ Serial #: _____ Hour Meter: _____

BUYER'S REPRESENTATIVE HAS RECEIVED INSTRUCTION IN PROPER OPERATION OF THE FOLLOWING CONTROLS AND FEATURES:

SCRUBBERS

- Filling solution tank, Solution tank sight tube, Solution drain hose or valve for flushing and freezing conditions
- Adjusting controls & operation, Double scrubbing, Squeegee lift delay, vacuum switch (horn honking) and vacuum timer
- Recovery tank draining & cleaning, vacuum screen removal and cleaning, drain saver basket emptied.
- Shroud and pad/brush removal and installation
- Side Wiper and Curtain adjustment and maintenance for water control
- Solution valve and filter operation (removal and cleaning)
- LCD display operation, 4 hour meters (key switch, brush, traction drive, vacuum)
- Tank tilt back feature, only when both tanks are fully drained
- Squeegee hose removal and checking for clogs

BURNISHERS

- Train and have customer demonstrate proper removal and replacement of burnishing pad
- Pad pressure gauge and proper operating range to avoid tripping the circuit breaker

SWEEPERS

- Demonstrate proper removal and replacement of main broom and side brooms
- Method for cleaning the dust filter, emptying out the debris hopper and correct installation
- Correct operation of the main broom and side broom levers, and understands to park with brushes in UP position
- Trained on the "Wet-Sweep" bypass door and not to operate through standing water

ALL MACHINES

- Checking battery electrolyte level and confirm monthly check that battery terminals are tight
- Parking brake override
- Charging operation and customer understands batteries have limited "cycles" and recharging = 1 cycle
- Seat and steering wheel adjustment
- Customer has read and understands the list of WARNINGS in the Operator manual
- Battery and Machine Maintenance Guide posters hung up and reviewed
- Manufacturer's website is a good source of information and sign up for quarterly newsletters

In addition to the above items the buyers representative has received the operator's manual and been advised to read the manual before operating the machine.

Installed By (print) _____ Signature _____

Buyers Representative (print) _____ Signature _____

Buyer agrees to pay for any repairs, adjustments, or secondary training that manufacturer determines is excluded from the warranty.

COMPLETE AND FAX FORM TO 1-866-632-6961 or online www.factorycat.com

Specifications

275

CONSTRUCTION

Frame:	(7-gauge) 3/16" steel
Rear Axle Capacity:	5,200 pounds
Rear Wheels (non-marking):	(2) 12" x 5"
Front Wheel Drive Capacity:	2,300 pounds
Front Wheel (non-marking):	(1) 12" x 4"
Dimensions: (L x W x H):	59" x 30" x 50"
Weight (w/ batteries):	1,566 pounds
Weight (w/out batteries):	846 pounds

BURNISHING SYSTEM

Pad Diameter:	(1) 27 inches
Pad Motor Power (standard):	(1) 4.0 hp
Pad Motor Power (optional):	(1) 4.0 hp
Pad Speed:	1527 rpm
Pad Engagement:	Dual Belt
Pad Pressure:	0 - 75 pounds
Pad Pressure Settings:	Infinite

BATTERY SYSTEM

Battery AH Rating:	(6) 396 AH or (12) 396 AH
Battery Run Time:	Up to 8 hours
Charger (110v / 60 Hz / automatic):	36 volt / 36 amp

FILTERING SYSTEM

Vacuum Description:	PASSIVE or ACTIVE
Filtering Material:	Polymer Felt
Filter Rating:	1 Micron
Size:	220 square inches
Filter Capacity:	150 cubic Inches
Screen Material:	Stainless Steel
Vacuum Power:	0.75 hp (optional)
Airflow Rating:	70 cfm

DRIVE SYSTEM

Transport Power:	2.0 hp
Forward Speed Control:	0 - 5 mph
Reverse Speed Control:	0 - 3 mph
Braking System:	Dynamic w/ Auto Parking Brake
Minimum Aisle for U-Turn:	63"

PRODUCTIVITY

Cleaning Rate/Hour (Max):	47,000 sq. ft./hr
Cleaning Rate/Hour (Normal):	36,849 sq. ft./hr

GENERAL

Sound Level:	70 dBA at Driver's Position
Gradeability:	11 degrees / 19%

Manufactured By:
R.P.S. Corporation
P.O. Box 386
Racine, WI 53401
Phone: (800) 634-4060 (N. America)
Fax: (866) 901-3335

Copyright R.P.S. Corporation 2005. All rights reserved.
Since our policy is one of constant improvement, all specifications are subject to change without notice.

Common wear parts

<u>Pad</u>	<u>Pad Function</u>	<u>Results</u>	<u>275 Part Number</u>
Image ultra high speed - beige	Ultra high speed High speed buffing And burnishing.	For high speed buffing and burnishing. For frequent burnishing on soft to medium finishes.	27-4221
Luster lite - blue	Ultra high speed buffing and burnishing.	For burnishing soft floor finishes. May be used on a daily basis. Ideally suited for top dressing highly polished floors.	27-4222
Combo ultra high speed	Ultra high speed buffing and burnishing.	Blended polyester and natural fibers. For frequent burnishing on medium finishes.	27-4223
Porko ultra high speed	Ultra high speed buffing and burnishing.	Blended natural fiber pad. For frequent minimal burnishing on hard finishes.	27-4224
Porko elite	Ultra high speed buffing and burnishing.	Blended natural fiber pad works on all UHS machines. For minimal burnishing on medium to hard finishes.	27-4225
Porko plus	Ultra high speed buffing and burnishing.	High content of natural fibers. Ideal for minimal burnishing on hard finishes.	27-4226

Safety Messages

Your safety, and the safety of others, is very important and operating this unit safely is an important responsibility.

To help you make informed decisions about safety, we have provided operating procedures and other safety information in this manual. This information informs you of potential hazards that could hurt you or others.

It is not practical or possible to warn you of all the hazards associated with operating this unit. You must use your own good judgment.

This is intended for commercial use. It is designed to be used on hard floors in an indoor environment, with the recommended pads.

1. DO NOT OPERATE UNIT:

Unless trained and authorized.
Unless operator manual is read and understood.
If unit is not in proper operating condition.

2. WHEN OPERATING UNIT:

Remove loose objects from the floor that may be projected from the revolving burnisher pad.
Keep hands and feet away from revolving pads.
Do not operate machine where flammable liquids or gasses are present.
Use extreme caution when maneuvering.

3. BEFORE LEAVING:

Make sure machine is turned off.
Stop on level surfaces.
Disconnect batteries.

4. BEFORE SERVICING:

Stop on level surface, and secure machine.
Disconnect batteries.

!! Safety Precaution!!

WARNING: Hazardous voltage. Shock, burns or electrocution can result. Always disconnect the batteries before servicing machine.

WARNING: Batteries emit hydrogen gases. Explosion or fire can result. Keep sparks and open flames away.

WARNING: Charge unit in a well ventilated area, and keep battery compartment open when charging. Explosion or fire could result.

WARNING: Battery acid can cause burns. Wear protective eye wear and gloves when servicing batteries.

WARNING: Do not store outdoors or pressure wash. Prevent electronic components from getting wet.

WARNING: The use of parts and solutions other than that recommended by the manufacturer may cause damage or endanger people.

WARNING: Dress safely. Do not wear rings or metal wrist watches while working on this machine. They can cause an electrical short, which, can cause serious burns. Do not work on this machine while wearing a tie, scarf or other loose, dangling neckware or clothing. These loose items can tangle in the rotating parts and cause serious injury or even death.

WARNING: Do not use the machine as a step ladder or chair.

WARNING: Only operate this machine from the operators position. It was not designed to carry passengers.

WARNING: Do not operate this machine on ramps or uneven surfaces. When climbing a ramp, always drive the machine in forward straight up or down the ramp. Never drive across the incline. Do not back down or turn on ramps!

WARNING: Always use the charger provided by the manufacturer to charge the machine. It is an automatic charger, specifically designed to charge at the appropriate rate. If you must use a different charger, disconnect the batteries before charging. This will prevent damage to the electronic speed controller.

WARNING: Understand the dynamic braking system before you operate the machine on ramps. Machine does not coast.

WARNING: Do not park the machine on ramps or slopes.

WARNING: Do not operate the machine if any parts have been removed or damaged.

WARNING: Do not remove, paint over, or destroy warning decals. If warning decals become damaged, they must be replaced.

WARNING: Do not operate machine in unsafe condition. If the machine is in need of repair or is in any way unsafe to operate, the matter should be reported immediately to the shift supervisor. Do not operate the machine until it is returned to proper operating condition.

WARNING: This machine must only be operated by trained operator. As part of his or her training, they must read this manual thoroughly. If extra copies are needed, contact your local dealer.

WARNING: Always turn off the machine, before leaving it unattended.

WARNING: Do not operate over electrical floor outlets. May result in serious injury.

Machine Controls and Features

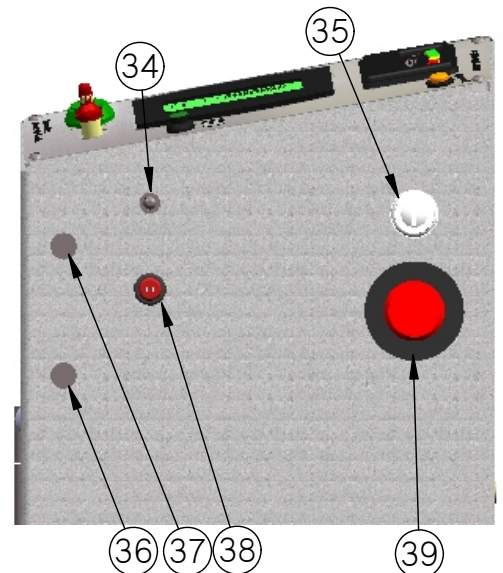
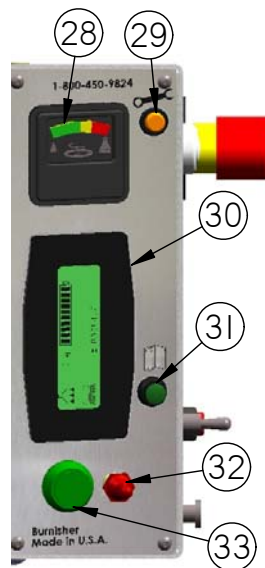
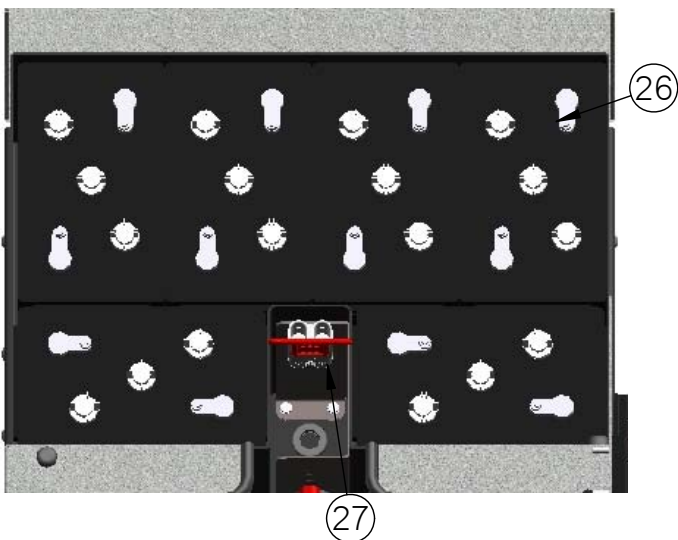
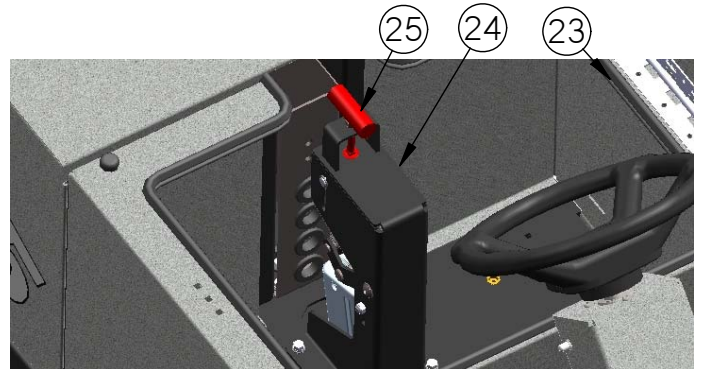
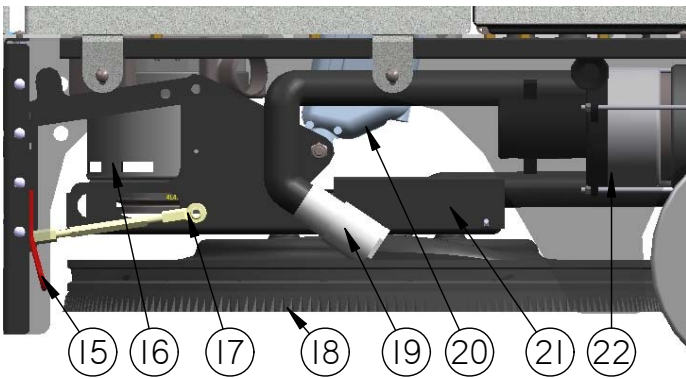
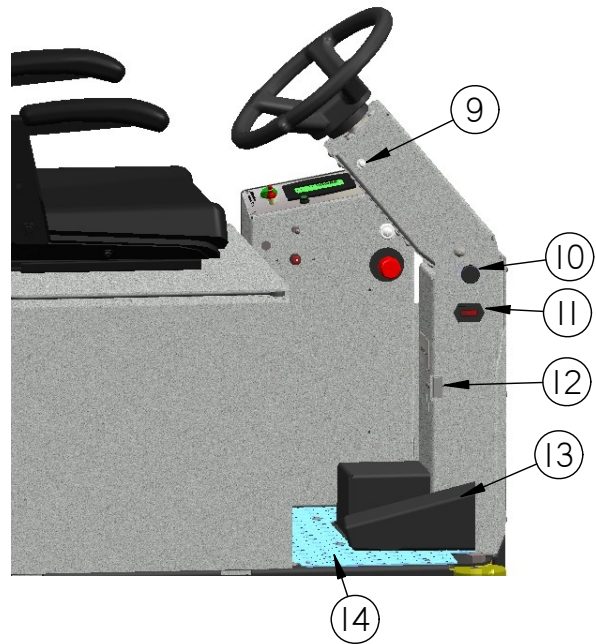
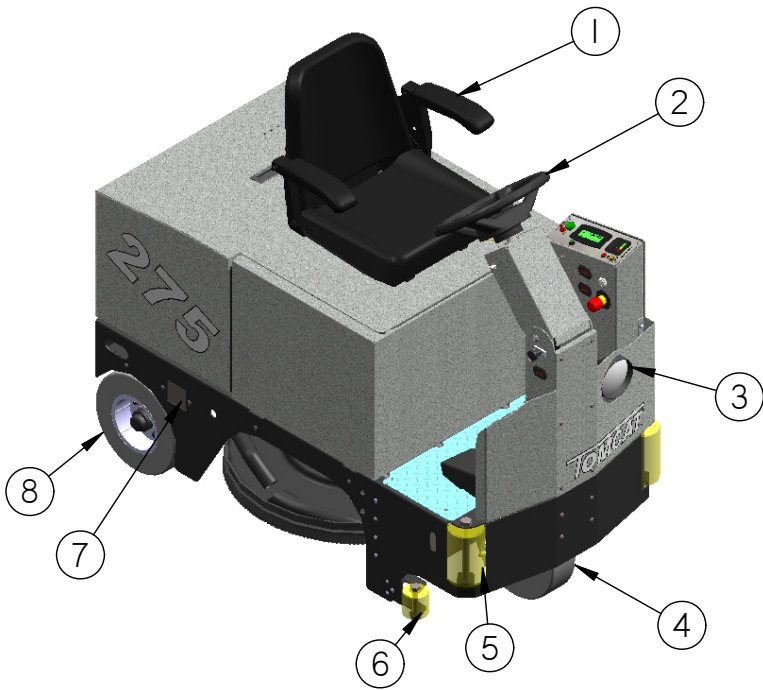

Controls and Functions

See figures (1-6) on page 7

1. **Seat:** Adjustable seat for operator comfort and ease of entry.
2. **Steering wheel:** Used to steer the machine.
3. **Headlight:** Helps you see in low light areas and to warn oncoming traffic.
4. **Front wheel:** Steers and propels machine.
5. **Corner roller bumpers:** helps prevent damage to machine when cleaning close to walls and other objects.
6. **Lower roller bumpers:** Helps prevent damage to deck.
7. **Onboard Charger:** Plug charger into outlet to charge machine. *(optional)*
8. **Rear tires:** Non-marking and extra wide tires for stability.

9. **Horn button:** sounds horn.
10. **Adjustable steering:** adjustable steering wheel for comfort and ease of entry.
11. **Hour Meter:** Keeps track of how many hours are on the machine.
12. **Charge port:** Gray 50 used to receive charger input. (Note: only use charger provided)
13. **Foot pedal:** Makes machine go and release pedal to stop.
14. **Non slip floor plate:** helps prevent slipping when getting on and off of machine.

15. **Quick disconnect power:** Allows you to easily disconnect power to the deck.
16. **Burnisher motor:** This motor drives the burnishing deck through two rpm reducing pulleys.
17. **Adjustable Arm:** Adjusts the pitch of the burnishing deck.
18. **Shroud:** The shroud contains dust created from burnishing.
19. **Dust control hose:** Two dust control hoses pull dust and debris from shroud to filter box.
20. **Actuator:** The actuator lifts and lowers the deck.
21. **Belt Guard:** The belt guard protects the belts and pulleys from debris.
22. **Vacuum motor:** Provides suction to vac box.

23. **Second Battery Compartment:** The machine is capable of holding a second set of six batteries.
24. **Actuator tower:** Provides down pressure adjustment.
25. **Spring Adjustment Knob:** Increases or decreases the pad pressure.

26. **Batteries:** The machine comes with one *(standard)* set of six batteries.
27. **Quick Disconnect battery plug:** Allows you to disconnect the batteries easily to work on machine safely.

28. **Burnishing deck pressure gauge:** Settings green (safe operating range) - red (overload).
29. **Burnishing motor brush indicator:** Indicates when the burnisher motor needs new brushes.
30. **LCD screen display:** Lists functions and settings of the machine.
31. **Menu control:** Scrolls through different options on the LCD display.
32. **Forward/Reverse switch:** Controls the direction of the traction motor.
33. **One touch button:** Activates the burnishing deck, and dust control system simultaneously.

34. **Vacuum switch:** Allows you to turn on vacuum motor separate from the one touch button.
35. **Key switch:** Turns power to machine on and off.
36. **(+) 15 amp resettable circuit breaker:** (15 amp) positive bus bar.
37. **(-) 15 amp resettable circuit breaker:** (15 amp) negative bus bar.
38. **Resettable 80 amp burnisher motor circuit breaker:** .
39. **Emergency shut off:** *(optional)* Shuts machine down in an emergency.

Machine Preperation

Uncrating machine

Carefully check the crate for any sign of Damage. Batteries are in the unit.

To uncrate the machine, remove banding from around the crate. Take off the top and sides And dispose of properly. Remove banding from machine. Remove the chocks around the drive wheels. Fold down ramp, and roll machine off of the base. Notify the carrier immediately if concealed damage is discovered.



Connecting batteries

Your machine is equipped with (six) 6 volt, Deep cycle, 395 amp hours batteries, which Form a 36 volt system. Maximum battery Dimensions are 7" w x 15" l x 15" h.

1. Turn all switches to the off position and remove key.
2. Hinge open the battery access lid to access the battery compartment.
3. All of the six battery cables are connected to the batteries. Locate any loose ones and connect to the open terminal. Tighten with 9/16" wrench. *(see below)*
4. Turn on main power switch and check the battery condition meter to ensure correct installation. Charge batteries if needed. *(see: battery charging)*

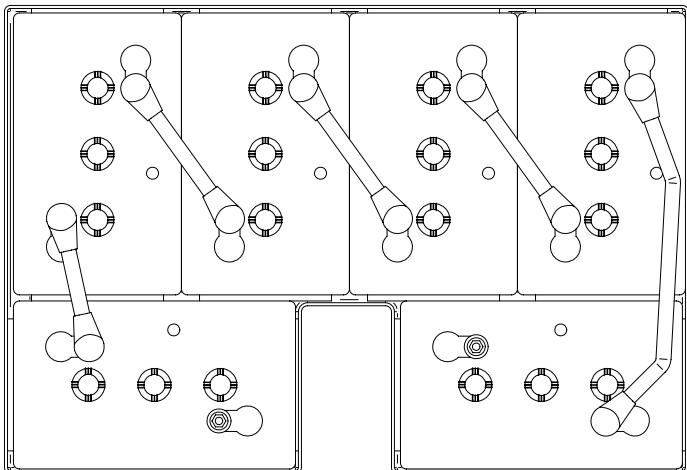

Connecting hoses

Your machine is also equipped with two vacuum hoses which need to be connected for the dust control to work properly.

1. Turn all switches to the off position.
2. Hinge open the battery access lid to access the rear of the filter box and fan connections.
3. Check to see if hoses are clamped down to the shroud and the filter box securely. (you should not be able to pull them off easily) if hoses are loose tighten the hose clamp with a screwdriver. *(see below)*

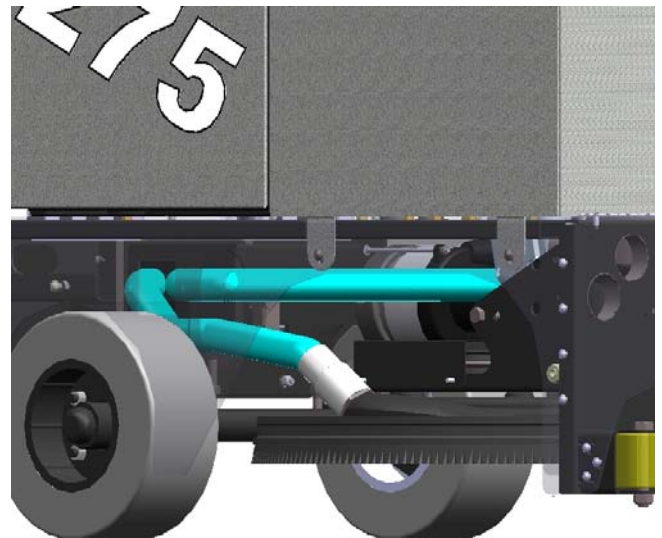

4. Check to see if hoses are clamped down to the shroud. Hose should have just enough slack to move up and down with the scrub deck and not interfere with other moving parts. *(See below)*

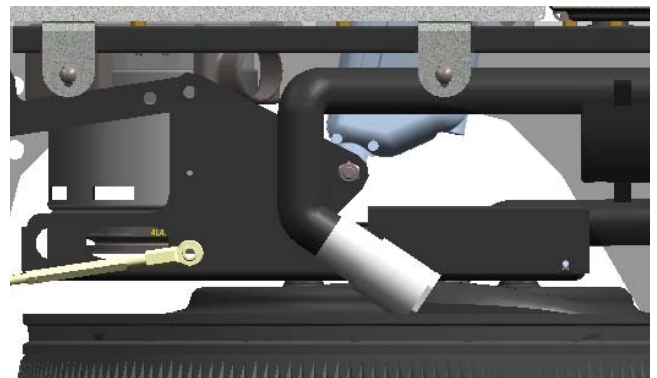

MACHINE SETUP

ATTACHING PAD

1. Turn on machine power

2. Assure that the deck is raised to the up position by verifying that the uni-touch button is not depressed (*A yellow ring will appear around the side of the uni-touch button*). Turn machine power back off and remove key. (*See right*)

3. Remove blue big mouth from pad holder.

4. Place pad on top of locking clip and slide both below burnishing deck directly into the center of one burnishing disk. (*see below*)

5. With pad and clip directly in the center of the burnishing disk push up and screw in the pad clip. (Hand tighten only) (*see below*)

6. Run machine and check for vibrations. If deck vibrates badly the pad may not be centered on disk correctly. Remove pad and reinstall pad in the center of disk.

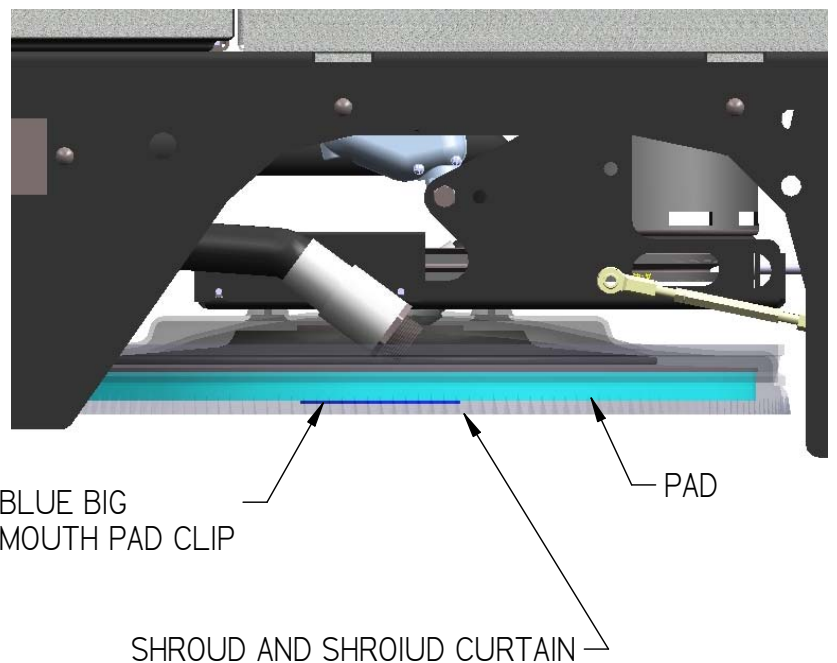
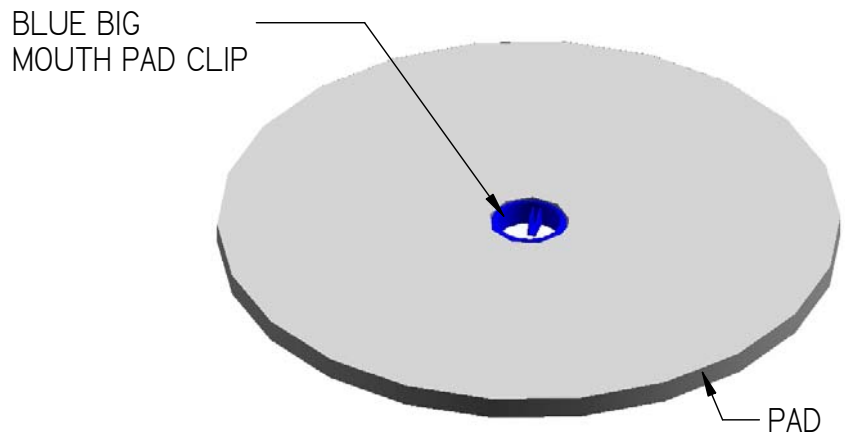
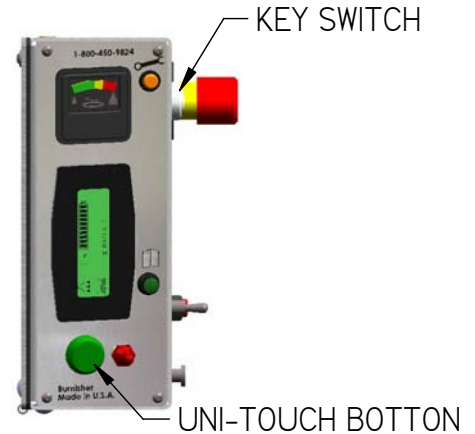

FOR CORRECT PAD APPLICATION, CALL YOUR LOCAL DEALER

Operation

Read and understand the safety section on page 5 and 6 before operating machine.

Pre- burnishing Check list

1. Check battery condition gauge on the central command II LCD screen. *(See below)* To check gauge push menu control button until battery gauge appears. Make sure batteries are fully charged before using.

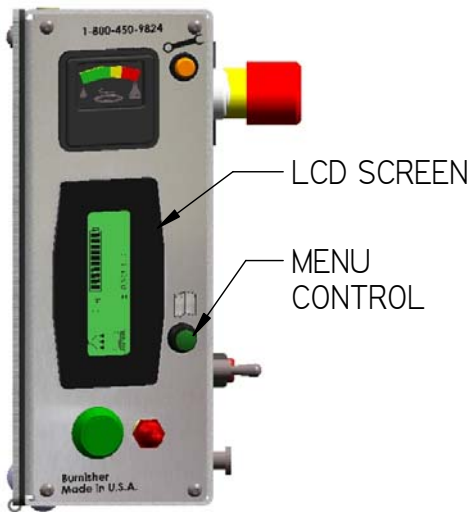

2. Check condition of pad and make sure it is securely in place.

3. Check hose connections from filter box to fan and, from filter box to shroud. *(See below)*

5. Check condition of shroud curtain shroud curtain needs to be in good condition for dust control system to work properly. *(See below)*

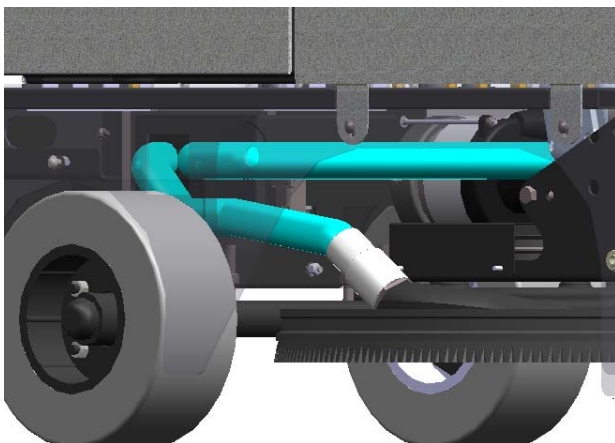

Operating hints

One Pass Burnishing

Steps: (see below)

1. Turn machine on with the key switch.

2. Lower burnishing head to the floor by simply depressing the green "uni touch" button.

3. The dust control will activate automatically when you begin burnishing.

4. Begin burnishing by depressing the foot pedal slowly and then to the speed required, the headlight will illuminate.

6. Once the pad begins to move, check the pressure gauge. Start burnishing with in the green marks, do not use yellow marks without management approval.

7. To operate machine in reverse, simply switch the reverse switch to the reverse position, back up alarm will sound (*if equipped*) and your speed is reduce to roughly 50% of forward speed.

8. To stop the machine, let off the foot pedal, and the machine will stop automatically.

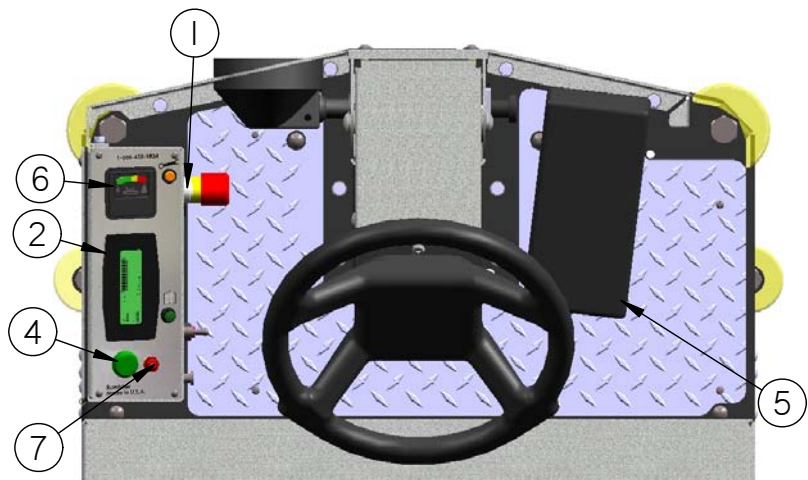

Battery charging

CAUTION: The following instructions are intended for the 36v charger supplied with the machine. Do not use any other charger with this machine.

Charger specifications

Output voltage of 36 volts.

Output current of 36 amps max.

Input voltage of 110 volts/60 Hz.

Automatic shut off circuit.

Made for deep cycle batteries.

Danger: always charge batteries in a well ventilated area. Batteries emit hydrogen gas. Explosion or fire can result. Keep sparks and flame away. Shield eyes when servicing batteries and avoid contact with battery acid. **Leave rear hood open when charging!**

1. Transport machine to a well ventilated area for charging.
2. Turn the machine off.
3. Hinge opens the battery access hood to expose the batteries. (Caution: always wear eye protection when batteries are exposed)
4. Check the water level in each battery. Do not charge the machine unless the water is slightly higher than the plates. If needed, add enough distilled water to just slightly cover the plates. Do not over fill. Batteries can overflow during charging. Replace caps before charging.
5. With the grey charger plug disconnected from the machine, plug the charger power cord into a grounded 110 volt standard wall outlet.
6. Connect the grey charger plug into the battery charging port located on the lower portion of the steering tower.
7. The charger will automatically begin charging, and automatically shut off when fully charged (check gauge)
8. After the charger has turned off, unplug the grey charger plug from the machine and disconnect the charger from the wall outlet.
9. Recheck the cell level after charging. If needed, add distilled water up to the correct level. Be certain to replace the caps securely and to wipe off the top of the batteries with a clean cloth.

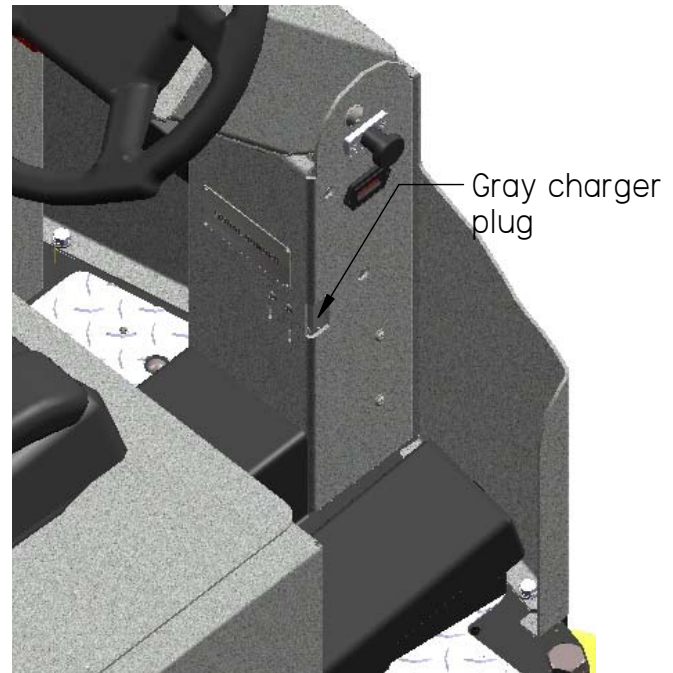
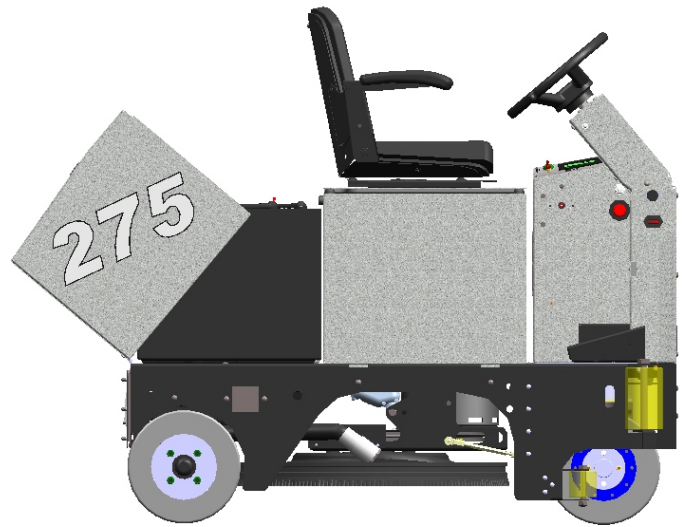

Maintenance

Daily Maintenance

1. Check pad condition. (Replace if necessary)
2. Check battery charge.
3. Clean dust control filters.
4. Check hoses and verify there are no clogs.
5. Check pads for wear and replace if needed.
6. Charge unit and verify that charger is operating properly

Monthly Maintenance

1. Check flex driver
2. Check to see if battery cables are tightened and clean. (Tighten if needed)
3. Check parking brake
4. Check condition of burnishing deck actuator.
5. Check condition of burnishing deck drive belts

Weekly Maintenance

1. Check battery water level.
2. Check condition of all three tires.
3. Check condition of dust curtains on shroud.
4. Check condition of dust control hoses.
5. Check to see if vacuum exhaust is clear.

Yearly Maintenance

1. Call your local dealer for yearly maintenance

Preventative maintenance records

CUSTOMER INFORMATION							
CUSTOMER							
ADDRESS							
CITY				STATE		ZIP CODE	
MACHINE INFORMATION							
MODEL #				SERIAL #			
WORK ORDER#				HOUR METER:			
BATTERY CONDITION			Cell #1	Cell #2	Cell #3		
Battery # 1 Hydrometer Reading							
Battery # 1 Water Condition							
Battery # 2 Hydrometer Reading							
Battery # 2 Water condition							
Battery # 3 Hydrometer Reading							
Battery # 3 Water Condition							
Battery # 4 Hydrometer Reading							
Battery # 4 Water condition							
Battery # 5 Hydrometer Reading							
Battery # 5 Water Condition							
Battery # 6 Hydrometer Reading							
Battery # 6 Water Condition							
Battery # 7 Hydrometer Reading							
Battery # 7 Water Condition							
Battery # 8 Hydrometer Reading							
Battery # 8 Water condition							
Battery # 9 Hydrometer Reading							
Battery # 9 Water Condition							
Battery # 10 Hydrometer Reading							
Battery # 10 Water condition							
Battery # 11 Hydrometer Reading							
Battery # 11 Water Condition							
Battery # 12 Hydrometer Reading							
Battery # 12 Water Condition							
Clean Battery Tops. Check Battery Cable and Terminal Condition							
NOTES:							
PAD CONDITION							
Pad			Good	Worn	Needs Replacement		
Pad retainer			Good	Worn	Needs Replacement		

Preventative maintenance records

PAD CONDITION							
Pad			Good	Worn	Needs Replacement		
Pad retainer			Good	Worn	Needs Replacement		
Pad Holder Condition			Good	Worn	Needs Replacement		
CHECK OPERATION AND CONDITION OF:							
	IN SPEC	REPAIR	PROBLEM				
Steering wheel Tilt Mechanism							
Key Switch							
Horn							
Head Light							
LCD Display							
Page Button							
Pad Pressure Adjustment							
Foot Pedal							
Reverse Switch							
Back Up Alarm							
Burnish Switch							
Burnishing Deck Lift System							
Pad Motors & Motor Brushes							
Active Vacuum Switch							
Vacuum Motor performance							
Strobe Light							
Battery Charger Connectors							
Battery Charger							

LCD Screen Menu Displays

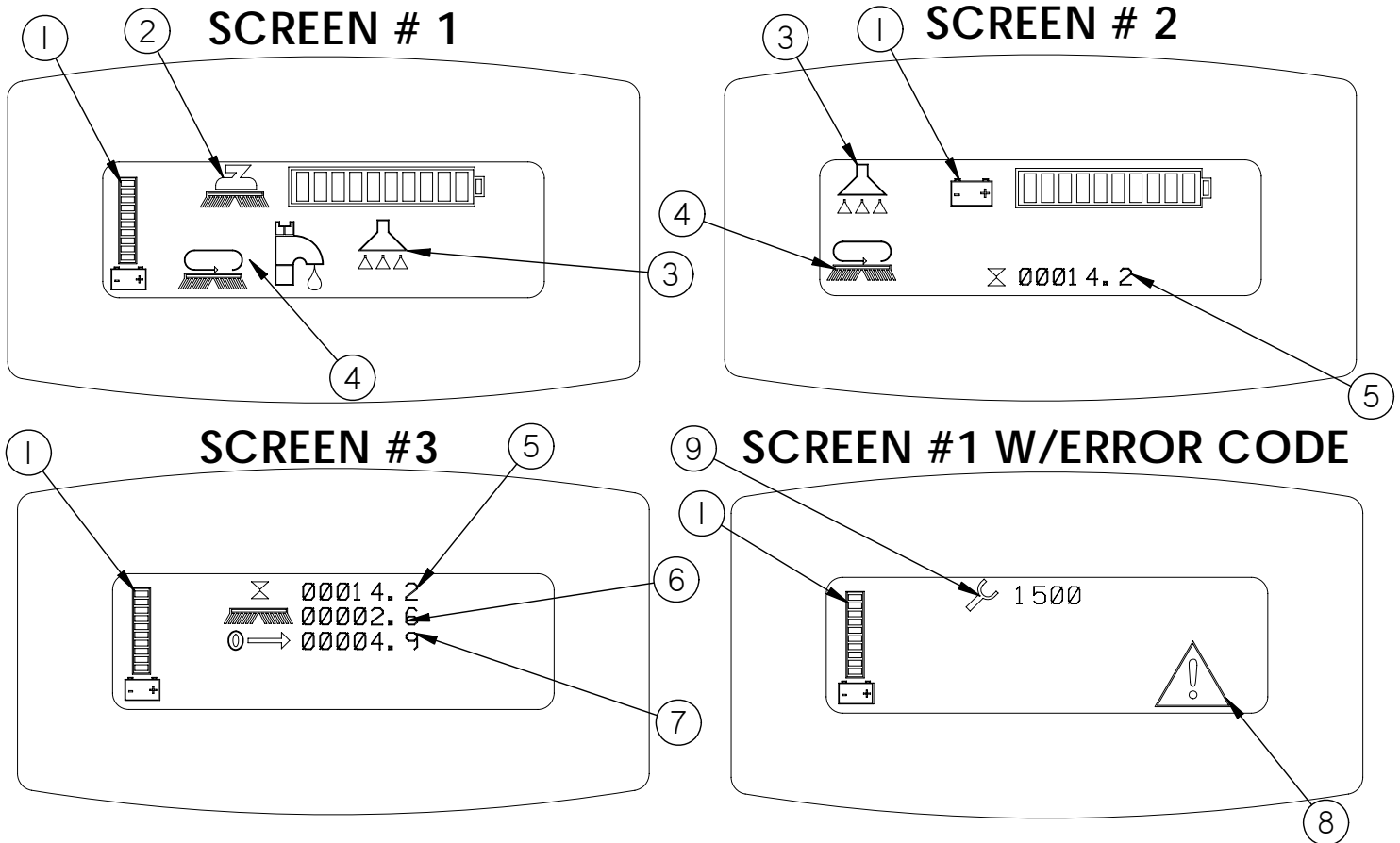

*** USE GREEN MENU SELECTION BUTTON ON CONTROL PANEL TO CHANGE SCREENS***

1. **Battery level indicator** - indicates the energy level remaining in the batteries. *(Shown on all menu displays)*
2. **Burnisher deck down pressure gauge** - Indicates pressure on the burnishing pads.
3. **Vacuum/fan on** - tells you when the active dust collection fan is on.
4. **Burnishing motors on** - tells you when the burnishing motor is running.
5. **Key switch hour meter** - tells you the total hours the machine has been on.
6. **Burnishing pad hour meter** - tells you the total hours the burnishing motors have been used.
7. **Transport hour meter** - tells you the total hours the drive system has been used.
8. **Error warning symbol** - indicates when there is machine fault,- Displays diagnostic error code.
9. **Diagnostic code** - when the machine has detected an error it will display the warning symbol and a diagnostic code which indicates what's wrong.

(For common error codes and descriptions see page 18)

Troubleshooting Central Command

NOTE: This machine is operated by a sophisticated electronic "*controller*" that has many fail-safes within it. The controller analyzes problems and displays a four-digit numeric code of what is wrong in the LCD window.

Most of these codes require a technician's attention. You should not attempt repairs you are uncomfortable with, especially if you are not used to working on electronics.

The complete list of codes is published in the simplified electronic troubleshooting manual, which is available to technical people. However, we have included the basic codes that you can usually resolve yourself.

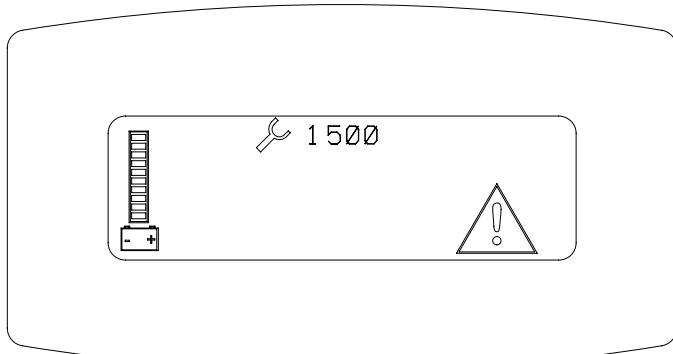

1. 1500 ERROR. Parking brake circuit fault. Call a technician.

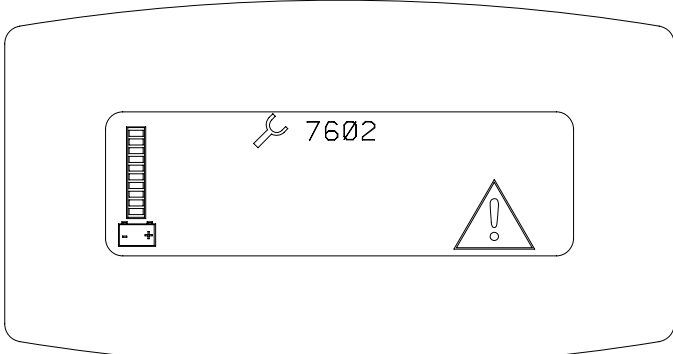

2. 7601 AND 7602 ERROR. Pad current over load. This can occur when the pads hit a bump in the floor. To restart the pads, turn off the key and turn it on again. To avoid this error, either slow down on bumpy parts of the floor, or reduce downpressure on the pads.

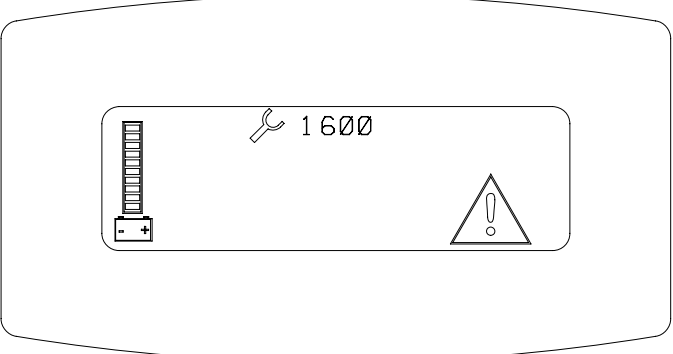

3. 1600 ERROR. Voltage exceeds the maximum. Either the batteries are mis-wired, or the charger is still plugged into the machine.

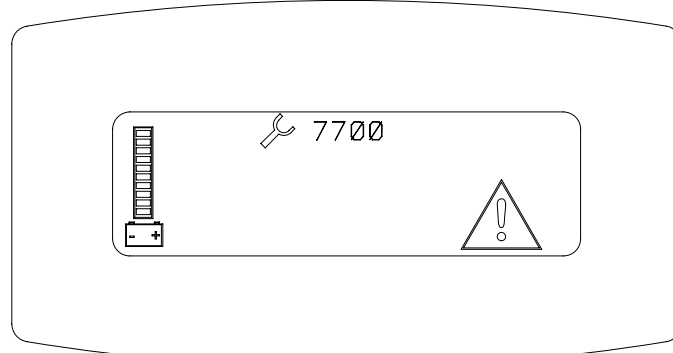

4. 7700, 7701, 7702, AND 7703 ERROR. The vacuum system has malfunctioned. Turn off key and turn on again to clear. If the code does not clear call a technician.

Troubleshooting Central Command

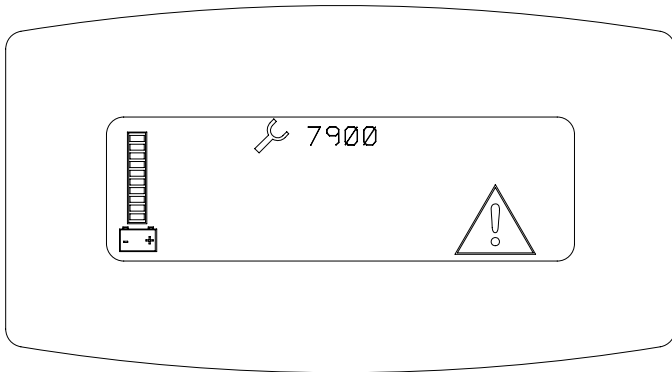

5. **7900 AND 7901 ERROR.** The emergency stop button is depressed.

6. **HIGH THROTTLE ERROR.** You pressed the drive button before turning on the key. Turn off the key, release the drive button and try again.

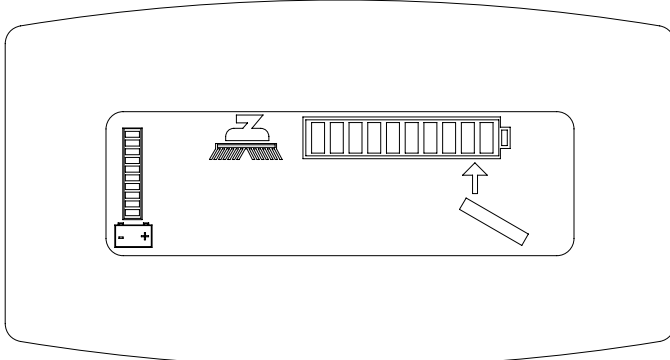

7. **2C00 AND 2C01 ERROR.** Low voltage warning. Voltage has dropped down below the minimum required to operate the machine. If you wait a few minutes, the batteries may coast up a bit in voltage, allowing you to drive very slowly to the recharge station.

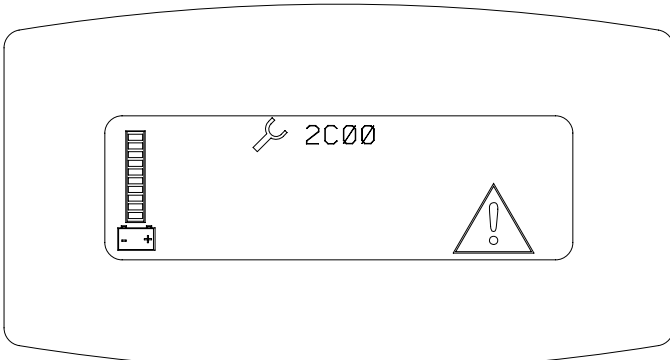

8. **7802 ERROR.** The traction motor was used to climb a ramp, and was running up the ramp for more than the 60 seconds allowed for this. Turn off the key, turn on again, and continue. You should not use this machine to climb ramps so steep and so long that this code comes up repeatedly, or you could overheat the traction motor.

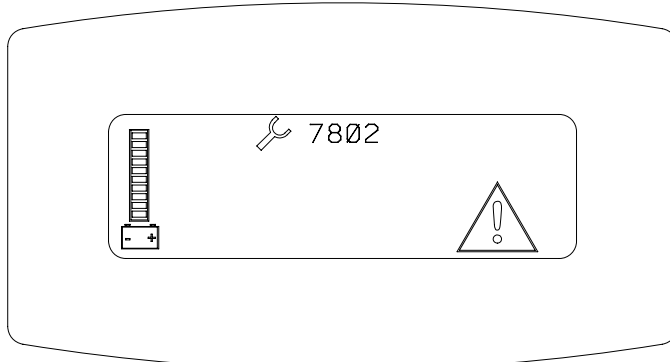

9. All other error codes. Turn off the key, and disconnect the positive battery cable from the batteries for more than one minute (*the time is needed to drain the controller's on-board capacitor*). Reconnect the cables, being sure that they are tight, if they are loose you will burn the battery cables or the battery. If you overtighten the cables you can damage the battery's lead terminal.

10. If the problem cannot be solved by any of these solution's call your local dealer's service department.

Trouble Shooting

<u>Problem</u>	<u>Cause</u>	<u>Solution</u>
No power, nothing operates.	Faulty key switch. Batteries need charging. Faulty battery. Loose battery cable. Main circuit breaker tripped.	Contact local servicing dealer. See charging batteries. Replace battery. Tighten loose cable. Wait 5 minutes for auto reset. determine cause and correct.
Burnishing motor does not operate.	Burnishing deck is not down. Foot pedal is not depressed. Burnishing circuit breaker tripped. Carbon brushes worn. Faulty motor or wires.	Put deck down. Engage foot pedal. Wait 5 minutes for auto reset Determine cause and correct. Contact local servicing dealer. Contact local servicing dealer.
Drive motor does not operate.	Recharge switch misadjusted. Faulty speed controller or wires. Faulty drive motor. Faulty wiring. Carbon brushes worn.	Contact local servicing dealer. Contact local servicing dealer. Contact local servicing dealer. Contact local servicing dealer. Contact local servicing dealer.
Dust control fan does not operate.	Faulty vacuum switch. Vacuum circuit breaker tripped. Faulty vacuum motor. Carbon brushes worn.	Try operating "white " toggle. Wait 5 minutes for auto reset. Determine cause and correct. Contact local servicing dealer. Contact local servicing dealer.
Drive motor runs incorrectly.	Faulty speed controller or wires. Faulty potentiometer. Loose wires.	Contact local servicing dealer. Contact local servicing dealer. Contact local servicing dealer.

Trouble Shooting

<u>Problem</u>	<u>Cause</u>	<u>Solution</u>
Poor dust control.	Main vacuum hose disconnected. Burnishing deck hose disconnected. Burnishing deck hose clogged. Damaged main vacuum hose. Damaged burnishing deck hose. Filter clogged. Filter door not closed tightly. Filter door gasket faulty. Filter full. Torn shroud curtain. Faulty vacuum Motor. Battery charge is low.	Reconnect hose. Reconnect hose. Remove debris. Contact local servicing dealer. Contact local servicing dealer. Clean out filters. Adjust screw on door clamp to tighten seal. Contact local servicing dealer. Remove debris. Contact local servicing dealer. Contact local servicing dealer. Charge batteries overnight.
Poor burnishing quality.	Burnishing pads worn out. Debris stuck to burnishing pad. Torn burnishing pad. Faulty disk pad motor. Battery charge is low.	Replace pads. Remove debris. Replace pads. Contact local servicing dealer. Charge batteries overnight.
Burnishing scrub deck noisy.	Missing burnishing pad. Burnishing pad worn out. Torn curtain hitting burnishing disks. Damaged shroud.	Replace pads. Replace pads. Contact local servicing dealer. Fix or replace shroud.
Rear tires noisy.	Bearings dry. Faulty hubs.	Grease bearings. Contact local servicing dealer.
Poor traction.	Excessive burnishing pad. Pressure. Worn drive tire.	Reduce pressure with switch. Contact local servicing dealer.
Short run time.	Batteries run down. Batteries still down. Batteries low on water. Batteries over cycled.	Charge batteries twice Contact local servicing dealer. Fill with distilled water to 3/4" above the lead plates. Contact local servicing dealer.