

**Clarke®**

*Encore Series* Walk-Behind Scrubbers



# High Performance Walk Behinds Meet Your Most Demanding Needs

## Hard Working Mid-Size Scrubbers

- Encore 24/26 features changeable scrub deck width (24 in. to 26 in.) to fit specific applications.
- 26 in. dual brush floating scrub deck on Encore L26 Cylindrical allows recovery of debris while scrubbing.
- 20 gallon solution and recovery tanks reduce trips to dump and refill tanks.
- 195, 250 or 330 AH battery packs extend the run-time for increased productivity (Encore L26 Cylindrical - 250 or 330 AH only).
- Infinitely variable forward and reverse traverse speed with easy-to-reach control dial (“L” Model only).

## Rugged Features - Designed To Last

- Patented break-away squeegee eliminates damage and offers no-tool blade change.
- Cast aluminum brush deck (Encore L26 Cylindrical) with wall rollers for strength and durability.
- Heavy duty transaxle cleans inclines and makes for easy loading and unloading.
- Warranty = 8 years tank and frame, 3 years parts, 1 year labor. No need to read the fine print ... **YOU'RE COVERED!**

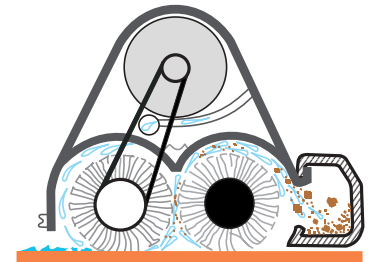
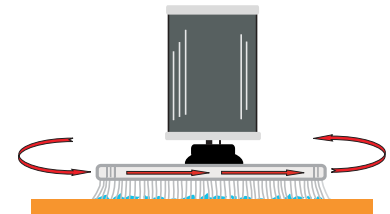

Choose disk scrubbing (above) or cylindrical scrubbing (below) with debris pick up to meet facility's cleaning needs.



Changing the scrub deck width on the Encore 24/26 from 24 to 26 inches is simply a matter of lifting the black knob and rotating the deck.



Easy access to brush replacement and servicing.



Why sweep before you scrub? Consider the Encore L26 Cylindrical. Debris is picked up while you scrub, which eliminates sweeping. The dual cylindrical scrub brushes clean tough dirt and grease imbedded in grout and cracks

# Service is a Breeze with the Encore 24/26 Scrubbers

*Easy-to-reach and refill batteries  
(250 AH or 330 AH)*

*Large, 20-gallon solution/recovery tanks  
meet long distance scrubbing needs.*



*Heavy-duty 1-hp motors provide  
more torque to the floor for more  
scrubbing power*

*Squeegee changing without  
any tools means more time  
scrubbing and less time  
maintaining the machine*

*Bristle type selection that  
meet your cleaning needs*

*The only walk-behind scrubber  
with true double-scrub capacity*



Flood control or off-aisle cleaning is an easy task with the spray and vac wand - a hard working option on the Encore 24/26.



Encore L26 Cylindrical counter-rotating brushes remove wood chips, gravel and rock without pre-sweeping. The combination of cleaning chemical and aggressive brushes will clean, disinfect and deodorize filthy otherwise hard to clean multi-surface floors.

# ENCORE™ Mid-Size Series

## Walk-Behind Scrubbers

# Clarke®

Division of  
**ALTO®**

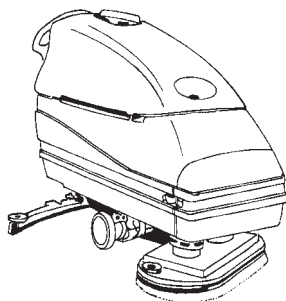

### KEY FEATURES

- Power forward and reverse
- Picks up water even in the tightest turns
- Floating brush deck
- Heavy duty brush drive motors provide aggressive scrubbing
- Impressive warranties

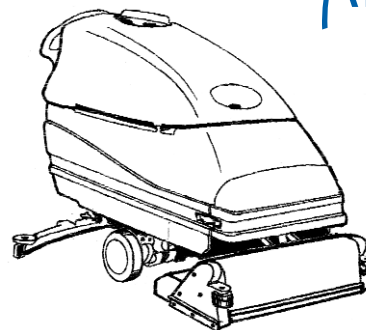

## SPECIFICATIONS

Model	24/26	L26 Cylindrical
<b>Power Supply</b>	(2) 12 Volt 195 AH, (4) 6 volt 250 or 330 AH, deep cycle batteries	24 Volt D.C. (4) 250 or 330 AH, deep cycle batteries
<b>Vacuum Motor</b>	.75 HP (.56 kW) 3-stage tangential discharge	
<b>Brush Motors</b>	(2) .75 HP (.56 kW)	.5 HP (.37 kW)
<b>Traction Motor</b>	.5 HP (.37 kW)	
<b>Cleaning Swath</b>	Variable 24 or 26 in. (61 or 66 cm)	26 in. (66 cm)
<b>Brush Down Pressure</b>	0 - 150 lbs. (0 - 68 kg)	100 lbs. (45.4 kg)
<b>Brush Size / Speed</b>	(2) 13 in. (33 cm) / 200 rpm	4 in. x 26 in. (10.1 cm x 66 cm) / 1000 rpm
<b>Traverse Speed</b>	Variable to 250 ft. (76 m) / min. forward and 190 ft. (58 m) / min. reverse	
<b>Forward / Reverse</b>		
<b>Solution / Recovery Tank</b>	20 / 20 gal. (75 / 75 l)	
<b>Squeegee Size / Type</b>	32 in. (81.3 cm) / Accu-Track™ w/break-away feature	39 in. (99 cm) / Accu-Track™ break-away feature w/3 position manual lever
<b>Drive Wheels / Casters</b>	(2) 8 in. x 2 in. (20.3 cm x 5 cm) neoprene tread / 4 in. x 2 in. (10.1 cm x 5 cm) dual casters	
<b>Dimensions L x W x H</b>	59 in. x 29 in. x 43 in. (150 cm x 73.7 cm x 109.2 cm)	
<b>Weight</b>	704 lbs. (319.3 kg) w/330 AH batteries	610 lbs. (276.7kg) with 250 AH batteries, or 710 lbs. (322 kg) with 330 AH batteries
<b>Shipping Weight</b>	953 lbs. (432.3 kg)	

### WHO USES THIS MACHINE?

- Manufacturing plants and warehouses
- Beverage, food production plants and bakeries
- Cleaning contractors
- Hospitals, schools

### WHAT DOES IT DO BEST?

- Maneuvers well into tight, confined areas
- Reduces operator fatigue with easy-to-operate controls
- Low maintenance provides more productivity and less downtime

### WHAT ENHANCES ITS PRODUCTIVITY?

- Battery packs to provide long run time
- Large solution/recovery tanks
- Heavy-duty brush drive motors
- Solution and brushes turn off when machine is not moving

### WHAT ADDS TO ITS DURABILITY?

- Heavy gauge welded steel chassis and Corrosion-proof Polydur® solution/recovery tanks
- Industrial quality switches and controls
- Break-away squeegee and non-marking solid wheels

### WHAT ARE THE SAFETY FEATURES?

- All electrical circuits with breaker protection
- Safety yellow palm start buttons
- Recovery tanks tilt 90 degrees for battery compartment access
- Recessed key switch to prevent unauthorized use

### WHAT ARE THE OPTIONAL FEATURES?

- Off-aisle spray and vac wand, parking brake, soft casters, pad drivers and wide variety of brushes
- ESP (recycling)
- Our meter

### Clarke®

2100 Hwy. 265  
Springdale, AR 72764

DISTRIBUTED BY:

Customer Service: 1-800-253-0367  
Fax Orders to: 1-800-825-2753  
Technical Service: 1-800-356-7274

©2002 ALTO U.S. Inc., All Rights Reserved. Specifications subject to change without notice. P/N 70393A