



5280

Scrubber

Model No.:
610678
610679 - PAC

Operator and Parts Manual

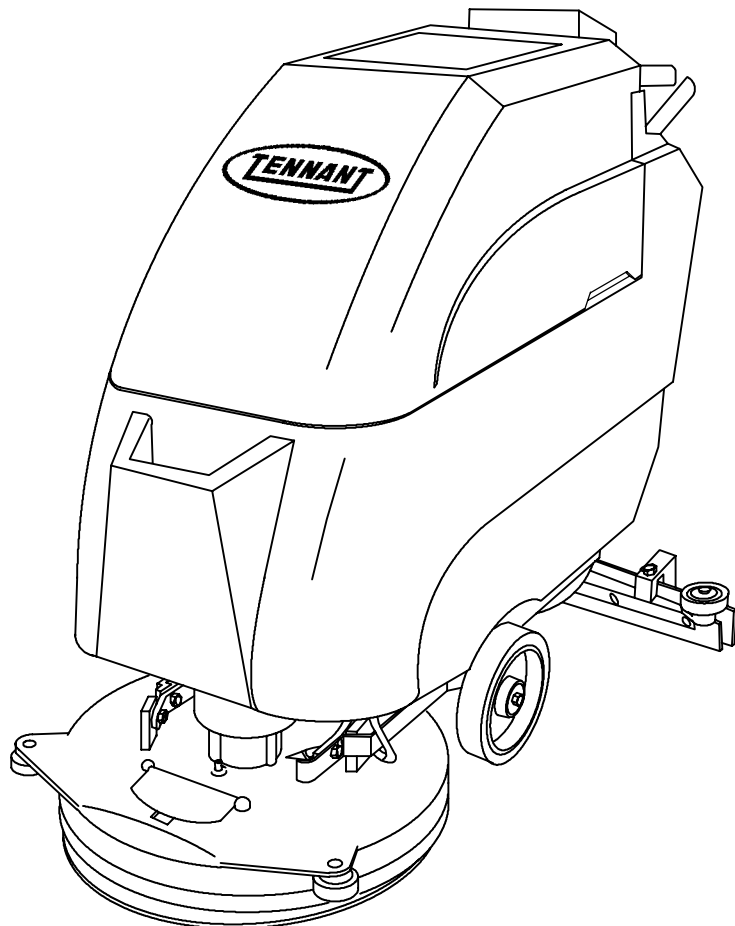

610168
Rev. 02 (10-04)

OPERATION

This manual is furnished with each new model. It provides necessary operation and maintenance instructions and an illustrated parts list.

Read this manual completely and understand the machine before operating or servicing it.

Use the illustrated Parts Lists to order parts. Before ordering parts or supplies, be sure to have your machine model number and serial number handy. Parts and supplies may be ordered by phone or mail from any authorized parts and service center, distributor or from any of the manufacturer's subsidiaries.

This machine will provide excellent service. However, the best results will be obtained at minimum costs if:

- The machine is operated with reasonable care.
- The machine is maintained regularly - per the maintenance instructions provided.
- The machine is maintained with manufacturer supplied or equivalent parts.

MACHINE DATA

Please fill out at time of installation for future reference.

Model No.- _____

Install. Date - _____

Serial No.- _____

©2000, 2002, 2004 Tennant Company

Printed in U.S.A.

Tennant Company

PO Box 1452

Minneapolis, MN 55440

Phone: (800) 553-8033 or (763) 513-2850

www.tennantco.com

TABLE OF CONTENTS

SAFETY PRECAUTIONS	4	MACHINE JACKING	24
SAFETY LABELS	5	TRANSPORTING MACHINE	24
MACHINE COMPONENTS	6	STORING MACHINE	24
CONTROLS AND INSTRUMENTS	7	RECOMMENDED STOCK ITEMS	24
CONTROL PANEL SYMBOLS	7	TROUBLESHOOTING	25
MACHINE INSTALLATION	8	SPECIFICATIONS	27
UNCRATING MACHINE	8	MACHINE DIMENSIONS	27
INSTALLING BATTERIES	8	ELECTRICAL DIAGRAMS	28
MACHINE SETUP	9	PARTS LIST	30
ATTACHING SQUEEGEE ASSEMBLY	9	REPLACEMENT BRUSHES AND	
LEVELING SQUEEGEE	9	PAD DRIVER GROUP	30
ATTACHING BRUSH/PAD DRIVER	10	SOLUTION TANK AND	
REMOVING BRUSH/PAD DRIVER	10	VACUUM MOTOR GROUP	32
ADJUSTING SCRUB HEAD SKIRT HEIGHT	11	SOLUTION CONTROL GROUP	34
FILLING SOLUTION TANK	11	RECOVERY TANK GROUP	36
MACHINE OPERATION	12	CONSOLE GROUP	38
PRE-OPERATION CHECKS	12	CONSOLE PANEL GROUP	40
SCRUBBING WITH MACHINE	12	MAIN FRAME GROUP	42
OPERATING ES (OPTION)	14	SCRUB HEAD LIFT GROUP	44
WHILE OPERATING MACHINE	15	SCRUB BRUSH DRIVE GROUP	46
CIRCUIT BREAKERS	15	SCRUB BRUSH DOWN PRESSURE GROUP	48
OPERATING OFF-AISLE WAND (OPTION)	15	SQUEEGEE LIFT GROUP	50
DRAINING TANKS	17	SQUEEGEE GROUP	52
DRAINING RECOVERY TANK	17	BATTERY AND CHARGER GROUP	54
DRAINING SOLUTION TANK	18	BATTERY CABLE GROUP	55
CHARGING BATTERIES	18	OPTIONS	56
BATTERY DISCHARGE INDICATOR	20	WET PICK-UP TOOL KIT	56
MACHINE MAINTENANCE	20	NON-POWER WAND GROUP	57
DAILY MAINTENANCE	20	POWER WAND GROUP	58
MONTHLY MAINTENANCE	21	DELUXE POWER WAND GROUP	60
QUARTERLY MAINTENANCE	22	NON-POWER WAND HOSE GROUP	62
BATTERY MAINTENANCE	22	POWER WAND HOSE GROUP	63
SQUEEGEE BLADE REPLACEMENT	23	ACCESSORY CONSOLE GROUP	64
SCRUB HEAD SKIRT REPLACEMENT	23	WAND PUMP PLUMBING GROUP	66
		ES (EXTENDED SCRUB)	
		PLUMBING GROUP	67
		SOUND KIT	68

SAFETY PRECAUTIONS

This machine is intended for commercial use. It is designed exclusively to scrub hard floors in an indoor environment and is not constructed for any other use. Use only recommended pads, brushes and commercially available floor cleaners intended for machine application.

All operators must read, understand and practice the following safety precautions.

The following warning alert symbol and the "FOR SAFETY" heading are used throughout this manual as indicated in their description:

 **WARNING:** To warn of hazards or unsafe practices which could result in severe personal injury or death.

FOR SAFETY: To identify actions which must be followed for safe operation of equipment.

Failure to follow these warnings may result in personal injury, electrical shock, fire or explosion.

 **WARNING:** Fire Or Explosion Hazard:

- Never Use Flammable Liquids Or Operate Machine in Or Near Flammable Liquids, Vapors Or Combustible Dusts.

This machine is not equipped with explosion proof motors. The electric motors will spark upon start up and during operation which could cause a flash fire or explosion if machine is used in an area where flammable vapors/liquids or combustible dusts are present.

- Do Not Pick Up Flammable Materials Or Reactive Metals.
- Batteries Emit Hydrogen Gas. Keep Sparks And Open Flame Away. Keep Battery Compartment Open When Charging.

 **WARNING:** Electrical Hazard. Disconnect Battery Cables Before Servicing Machine.

 **WARNING:** Spinning Brush. Keep Hands Away. Turn Off Power Before Working On Machine.

The following information signals potentially dangerous conditions to the operator or equipment:

FOR SAFETY:

1. Do not operate machine:
 - With flammable liquids or near flammable vapors as an explosion or flash fire may occur.
 - Unless trained and authorized.
 - Unless operation manual is read and understood.
 - If not in proper operating condition.
2. Before operating machine:
 - Make sure all safety devices are in place and operate properly.
3. When using machine:
 - Go slow on inclines and slippery surfaces.
 - Wear non-slip shoes.
 - Reduce speed when turning.
 - Report machine damage or faulty operation immediately.
 - Never allow children to play on or around.
 - Follow mixing and handling instructions on chemical containers.
4. Before leaving or servicing machine:
 - Stop on level surface.
 - Turn off machine.
 - Remove key, if equipped.
5. When servicing machine:
 - Avoid moving parts. Do not wear loose jackets, shirts, or sleeves.
 - Block machine tires before jacking up.
 - Jack machine up at designated locations only. Block machine up with jack stands.
 - Use hoist or jack that will support the weight of the machine.
 - Do not power spray or hose off machine. Electrical malfunction may occur.
 - Disconnect battery connections before working on machine.
 - Wear protective gloves and eye protection when handling batteries or battery cables.
 - Avoid contact with battery acid.
 - Use manufacturer supplied or approved replacement parts.
 - All repairs must be performed by a qualified service person.
 - Do not modify the machine from its original design.

6. When transporting machine:

- Turn machine off.
- Get assistance when lifting machine.
- Do not lift machine when batteries are installed.

- Use a recommended ramp when loading/unloading into/off truck or trailer.
- Use tie-down straps to secure machine to truck or trailer.
- Put the scrub head in the lowered position.

SAFETY LABELS

The safety labels appear on the machine in the locations indicated. Replace labels if they are missing or become damaged or illegible.

WARNING LABEL -

Located on the recovery tank cover.



READ MANUAL LABEL -

Located on control panel.

FOR SAFETY: Do not operate machine unless operator manual is read and understood.

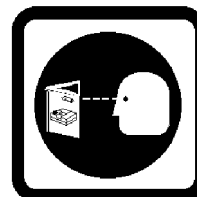

MOVING PARTS LABEL -

Located on scrub head

⚠ WARNING: Spinning Brush. Keep Hands Away. Turn Off Power Before Working On Machine.

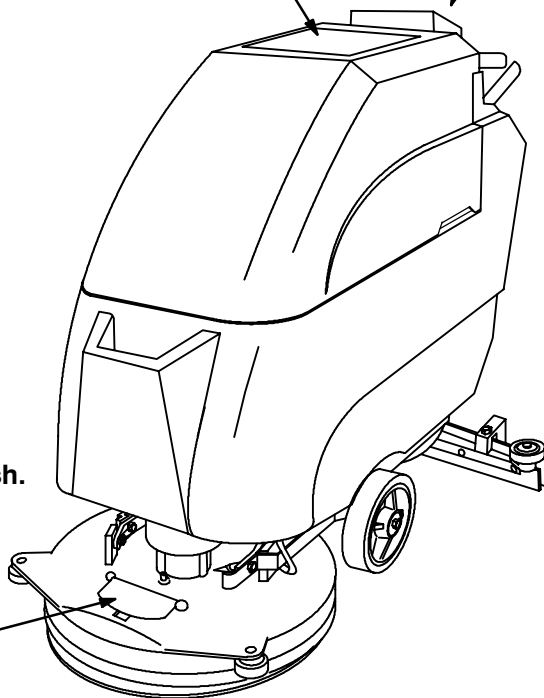



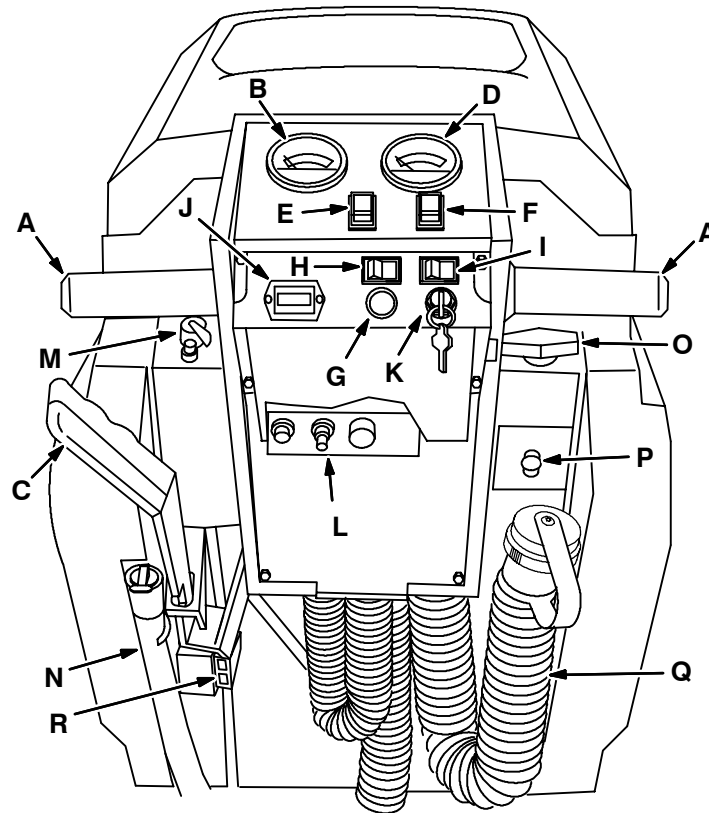









CONTROLS AND INSTRUMENTS



- | | |
|--------------------------------|-------------------------------|
| A. Control Grips | J. Hourmeter (Option) |
| B. Battery Discharge Indicator | K. On-off Key Switch (Option) |
| C. Squeegee Lever | L. Circuit Breakers |
| D. Brush Pressure Gauge | M. Solution Flow Knob |
| E. Machine Power Switch | N. Solution Tank Drain Hose |
| F. Solution Switch | O. Brush Pressure Knob |
| G. ES Pump On Light (Option) | P. Brush Pressure Indicator |
| H. ES Switch (Option) | Q. Recovery Tank Drain Hose |
| I. Power Wand Switch (Option) | R. Charger Plug |

CONTROL PANEL SYMBOLS

- | | | | |
|---|--|---|--|
|  Main Power |  Light Brush Pressure |  Extended Scrub (Option) |  Scrub Brush Circuit Breaker |
|  Key Switch (Option) |  Heavy Brush Pressure |  ES Pump Light (Option) |  Vacuum Motor Circuit Breaker |
|  Solution Flow |  Hour Meter (Option) |  Off-Aisle Wand (Option) |  Main Power Circuit Breaker |
|  Battery Discharge Indicator | | | |

OPERATION

MACHINE INSTALLATION

UNCRATING MACHINE

1. Carefully check carton for signs of damage. Report damages at once to carrier.
2. Check Carton Contents list, contact distributor for missing items.

Carton Contents:

- 1 - Battery Tray #601991
- 1 - Red Battery Cable #603061
- 4 - Battery Post Caps #45962
- 1 - Red Battery Boot #611222
- 1 - Black Battery Boot #611221
- 2 - Bumper Wheels #579184 (to be installed on scrub head)
- 4 - Battery Spacers #630375
- 1 - Squeegee Assembly #610989
- 2 - Batteries #130869 (included with Machine PAC #610679)
- 1 - Battery Charger #603553 (included with Machine PAC #610679)
- 1 - Pad Driver #222303 (included with Machine PAC #610679)

NOTE: Brushes and Pads must be purchased separately.

3. To uncrate your machine, unbolt scrub head from shipping pallet and remove the shipping hardware and straps that secure the machine to the pallet. Position a ramp at the rear of the machine and carefully back the machine off the pallet.

ATTENTION: Do not roll machine off pallet unless a ramp is used, machine damage may occur.

ATTENTION: To prevent possible machine damage, install batteries after removing machine from shipping pallet.

4. Install bumper wheels on scrub head.

INSTALLING BATTERIES

⚠ WARNING: Fire Or Explosion Hazard. Batteries Emit Hydrogen Gas. Keep Sparks And Open Flame Away. Keep Battery Hood Open When Charging.

FOR SAFETY: When servicing machine, wear protective gloves and eye protection when handling batteries and battery cables. Avoid contact with battery acid.

Recommended Battery Specifications:

Two 12 volt, deep cycle, 130 Amp hour lead acid batteries. Maximum battery dimensions are 178 mm (7 in) W x 381 mm (15 in) L x 372 mm (14.63 in) H.

1. Hinge open recovery tank to access battery compartment (Figure 1).

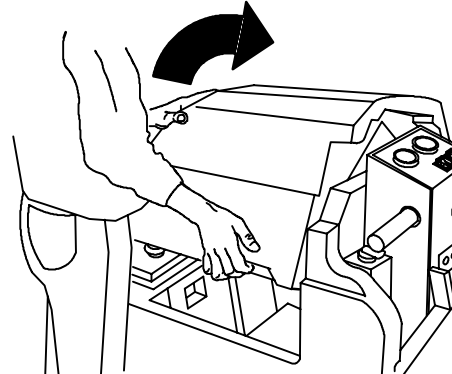

FIG. 1

2. Carefully install batteries into battery compartment tray with battery posts positioned as shown. Secure batteries with battery stops (Figure 2).

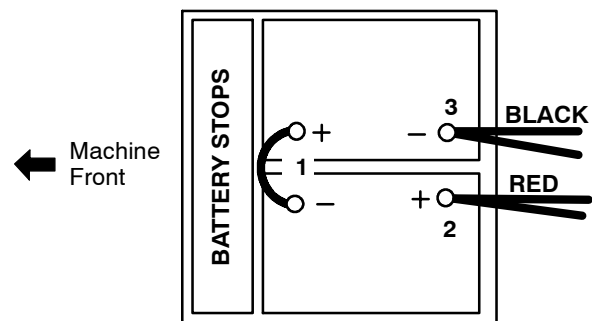

FIG. 2

ATTENTION: Do not drop the batteries into the compartment, battery and machine housing damage may result.

3. Before connecting battery cables, make sure terminals and posts are clean. Use a post cleaner and wire brush to clean posts and terminals.
4. Apply a light coating of non-metallic grease or protective spray on the cable connections to prevent battery corrosion.
5. Connect cables to battery posts in numerical order as labeled, RED TO POSITIVE & BLACK TO NEGATIVE, use battery post covers and rubber boots supplied (Figure 2).
6. Check battery discharge indicator. Machine must be in full operation for accurate reading (See MACHINE OPERATION). Charge batteries if necessary.

MACHINE SETUP

ATTACHING SQUEEGEE ASSEMBLY

FOR SAFETY: Before leaving or servicing machine, stop on level surface and turn off machine.

1. Pull squeegee lever outward and to the right to lock the squeegee pivot bracket in the raised position (Figure 3).

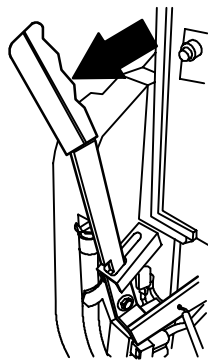

FIG. 3

2. Place squeegee under pivot bracket, line up mounting studs with squeegee slots and tighten thumbscrews (Figure 4).

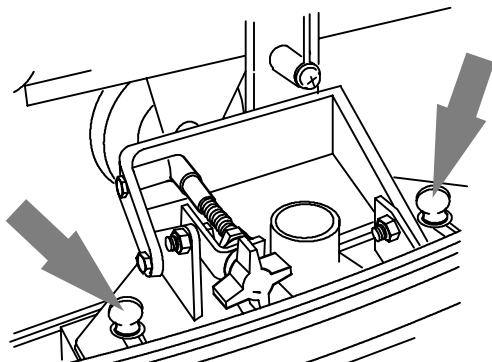

FIG. 4

3. Connect the vacuum hose to the squeegee assembly. Loop the hose as shown using the hose clip provided (Figure 5).



FIG. 5

4. Lower squeegee, push machine forward and check that the blade has even contact the full length of the squeegee (Figure 6). If blade is not even, leveling is required (See LEVELING SQUEEGEE).

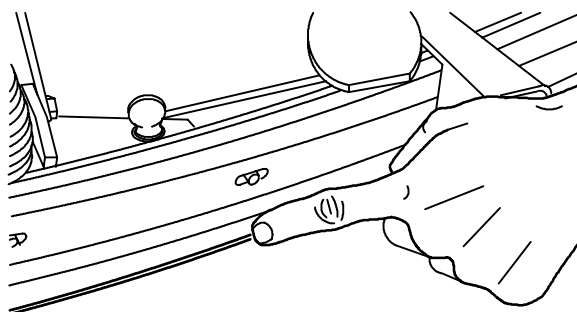

FIG. 6

LEVELING SQUEEGEE

Leveling of squeegee assures even contact the length of squeegee blade. Make sure floor is level when making adjustments.

FOR SAFETY: Before leaving or servicing machine, stop on level surface and turn off machine.

1. Lower squeegee to floor.
2. Push machine forward to deflect squeegee blade (Figure 6).
3. Turn the squeegee leveling knob counter-clockwise to decrease deflection at squeegee ends, or clockwise to increase (Figure 7).

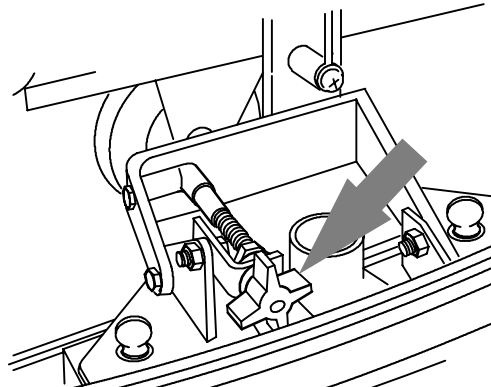

FIG. 7

4. Push machine forward again to check blade deflection, readjust squeegee leveling knob as necessary.

OPERATION

ATTACHING BRUSH/PAD DRIVER

NOTE: Consult your authorized distributor for pad and brush recommendations.

1. Cleaning pads must be placed on pad drivers before attaching pad driver. Secure cleaning pad to pad driver with center lock (Figure 8).

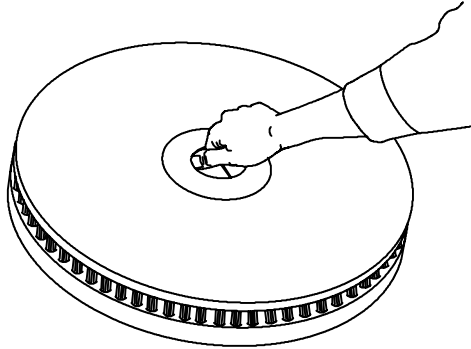

FIG. 8

2. Turn machine power off.

FOR SAFETY: Before leaving or servicing machine, stop on level surface and turn off machine.

3. Raise the scrub head with the scrub head lift pedal (Figure 9).

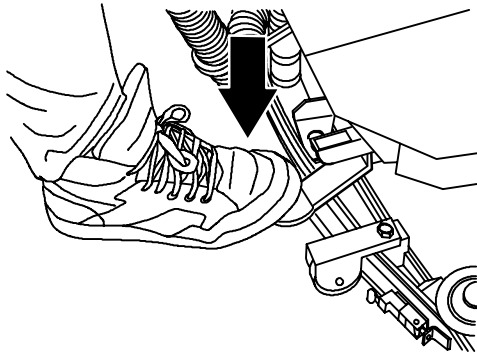

FIG. 9

4. Open access cover on front of scrub head. Turn drive plate until pin slot is visible (Figure 10).

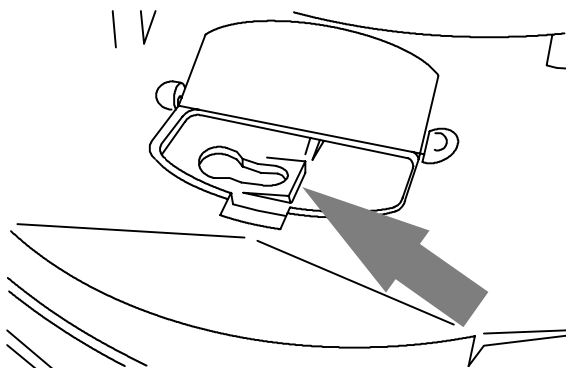

FIG. 10

5. Place scrub brush under scrub head. Make sure one of brush drive pins is facing front (Figure 11).

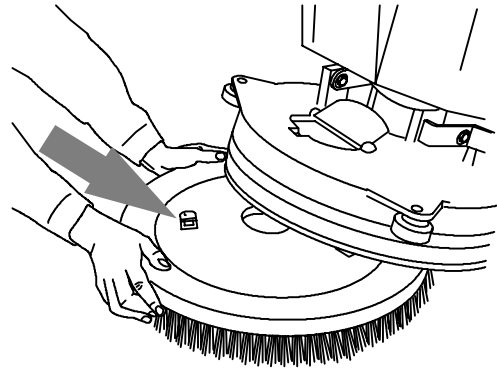

FIG. 11

6. Align brush drive pin with the drive pin slot on drive plate. Lift scrub brush and turn brush counter-clockwise to engage drive pins into drive slots (Figure 12).

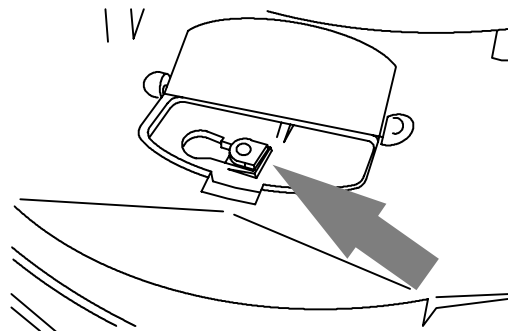

FIG. 12

7. Check the brush to make sure it is securely mounted on the brush drive hub. Close the scrub head access cover.

REMOVING BRUSH/PAD DRIVER

1. Turn machine power off.

FOR SAFETY: Before leaving or servicing machine, stop on level surface and turn off machine.

2. Raise the scrub head with the scrub head lift pedal (Figure 13).

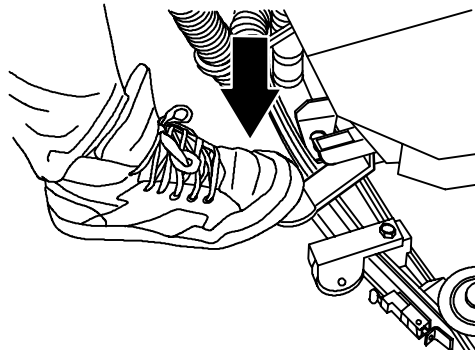

FIG. 13

- Open access cover on scrub head and turn brush until drive pin is visible (Figure 14).

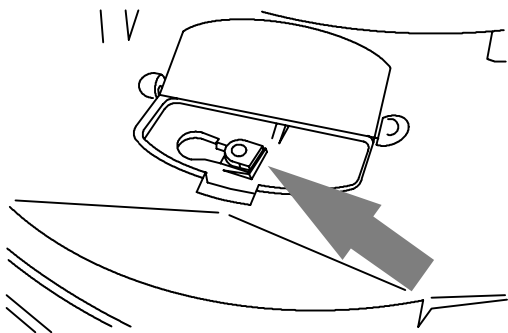

FIG. 14

- Press down on the brush lock pin and turn brush clockwise. The brush will drop off drive plate (Figure 15).

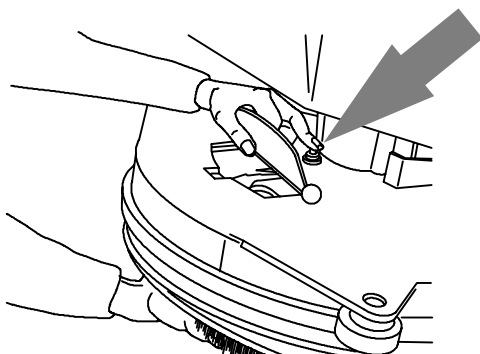

FIG. 15

- Adjust skirt height by sliding skirt up or down by hand. Skirt band clamp should only be slightly tightened to allow for easy hand adjustment (Figure 17).

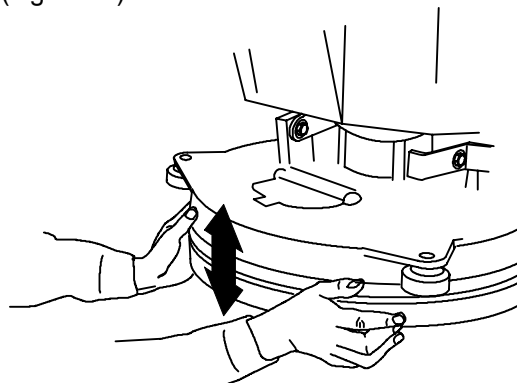

FIG. 17

- If skirt band is too tight, slightly loosen clamp at rear of scrub head (Figure 18).

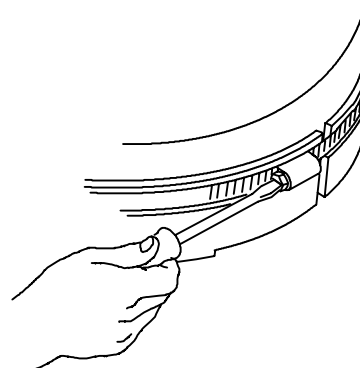

FIG. 18

ADJUSTING SCRUB HEAD SKIRT HEIGHT

- Place machine on a level surface and turn off machine.
- Lower scrub head with pad/brush installed.
- Check to see if skirt height is 1.5 mm (.062 in.) from floor all away around scrub head (Figure 16).

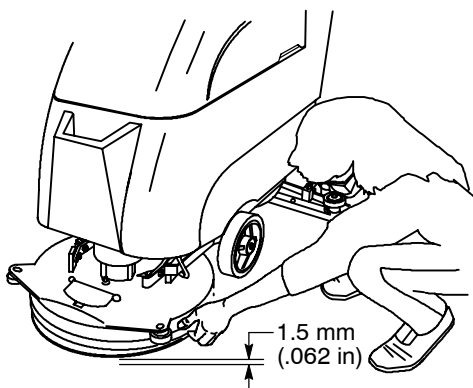

FIG. 16

FILLING SOLUTION TANK

- Push machine to filling site and turn off machine.

FOR SAFETY: Before leaving or servicing machine, stop on level surface and turn off machine.

- Remove the fill-port cover at the front of the machine and fill solution tank to the opening screen with clean water, 60°C (140°F) maximum (Figure 19).

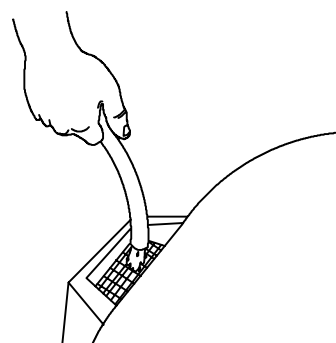

FIG. 19

OPERATION

NOTE: The water must **not** be hotter than 60°C (140°F) or tank damage may occur.

NOTE: If filling with a bucket be certain that bucket is clean. This will prevent possible solution line clogs.

3. Add cleaning chemical. See proper dilution ratio instructions on bottle. Solution tank capacity is 45L (12 gal).

FOR SAFETY: When using machine, follow mixing and handling instructions on chemical containers.

ATTENTION: Use only recommended detergents. Machine damage due to improper detergent usage will void the manufacturer's warranty. Contact your Tennant Sales Representative for detergent recommendations.

⚠ WARNING: Fire Or Explosion Hazard. Never Use Flammable Liquids.

4. ES Mode Option: Open the recovery tank cover and fill the recovery tank with no more than 23L (6 gal) of water (Figure 20).

NOTE: When using the ES option, make sure to activate the ES option ON/OFF switch.

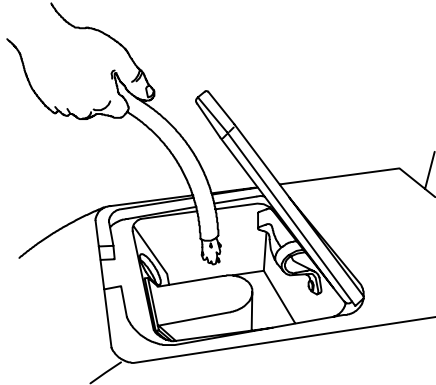

FIG. 20

MACHINE OPERATION

FOR SAFETY: Do not operate machine, unless operation manual is read and understood.

⚠ WARNING: Fire or Explosion Hazard. Never Operate Machine In Or Near Flammable Liquids, Vapors Or Combustible Dusts.

PRE-OPERATION CHECKS

1. Sweep floor and pick up any material which could become wrapped around scrub brush.
2. Check battery discharge indicator. For accurate reading, machine must be in operation.
3. Check that pads/brushes are installed (See MACHINE SETUP).
4. Check squeegee for proper deflection (See MACHINE SETUP). Check blade for wear, rounded corners, nicks or cuts.
5. Check that scrub head skirt is approximately 1.5 mm (.062 in.) from the floor all the way around scrub head.

SCRUBBING WITH MACHINE

1. Adjust control console to a comfortable operating height. To adjust height, pull control console trigger, move console up or down, then release trigger (Figure 21).

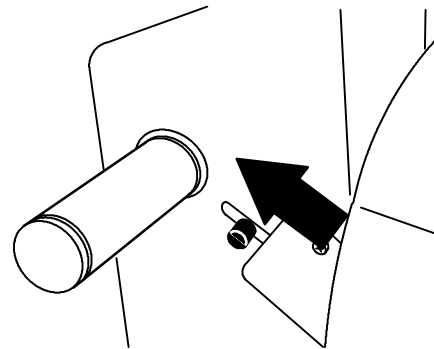

FIG. 21

2. Push machine to area to be scrubbed. Make sure scrub head and squeegee are raised off floor.

- Turn on machine power switch, and key switch if equipped (Figure 22).

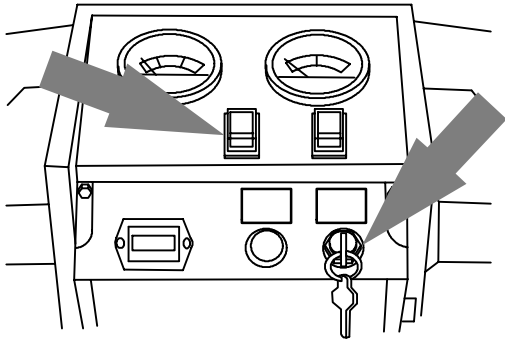

FIG. 22

- ES SCRUBBING: Press the right side of the ES switch to activate the ES system. The switch will light up (Figure 23).

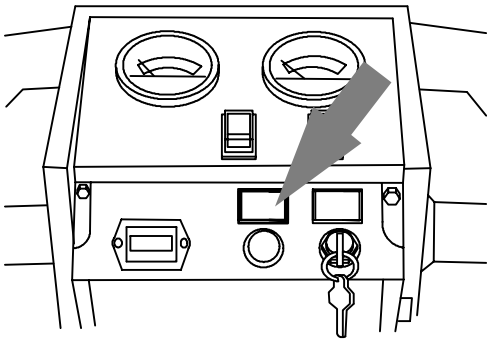

FIG. 23

- Lower squeegee to floor with squeegee lever. This lever will also turn on vacuum system (Figure 24).

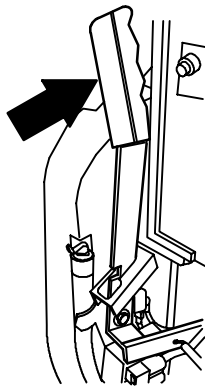

FIG. 24

- Turn solution switch on. The solution will not flow until control grips are rotated (Figure 25).

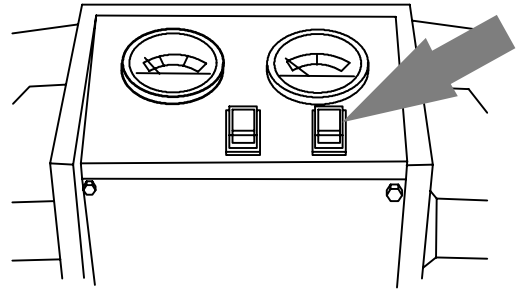

FIG. 25

- Lower the scrub brush by stepping down on the scrub head release pedal (Figure 26).

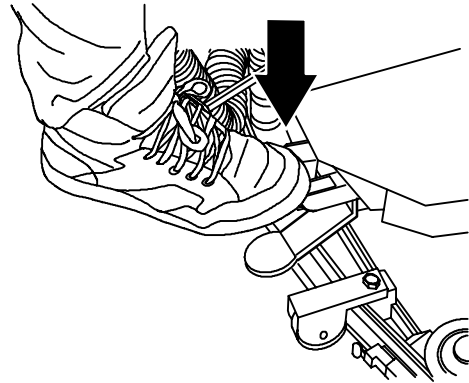

FIG. 26

- Rotate control grips in either direction and push machine forward to begin scrubbing. The scrub brush will assist in propelling the machine forward (Figure 27).

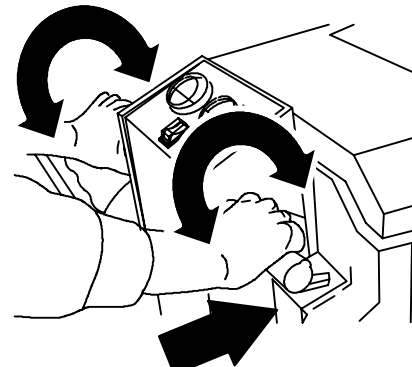

FIG. 27

⚠ WARNING: Fire Or Explosion Hazard. Do Not Pick Up Flammable Materials Or Reactive Metals.

OPERATION

- Adjust solution flow rate. Turn solution flow knob counter-clockwise to increase flow or clockwise to decrease (Figure 28).

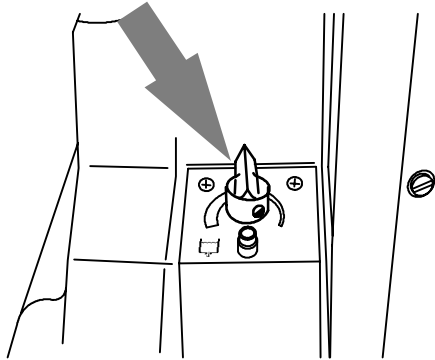

FIG. 28

- Turn brush pressure knob to adjust pressure for cleaning application. The indicator below the knob shows if brush pressure is increasing or decreasing (Figure 29).

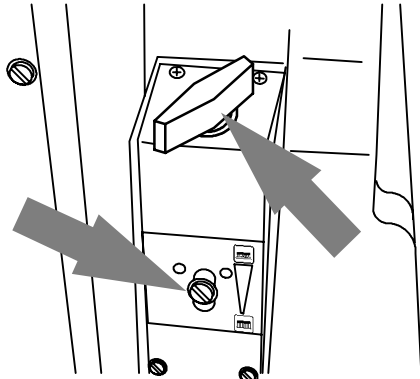

FIG. 29

- Observe brush pressure gauge. The brush pressure gauge should be operated in the GREEN zone. Operating machine with gauge in the RED zone will cause scrub brush circuit breaker to trip (Figure 30).

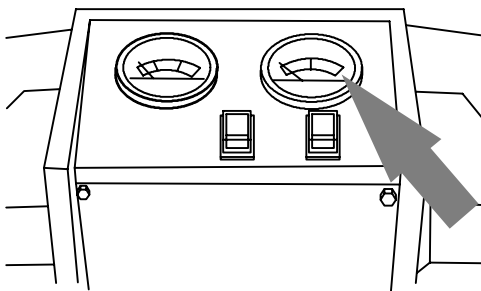

FIG. 30

OPERATING ES (OPTION)

ES option extends scrubbing time by reusing recovered water. The recovered water is filtered and recycled back into the solution tank for reuse.

- Pour up to 23L (6 gal) of clean water, 60° C (140° F) maximum temperature, into recovery tank when filling solution tank (Figure 31).

⚠ WARNING: Fire Or Explosion Hazard. Never Use Flammable Liquids Or Operate Machine In Or Near Flammable Liquids, Vapors Or Combustible Dusts.

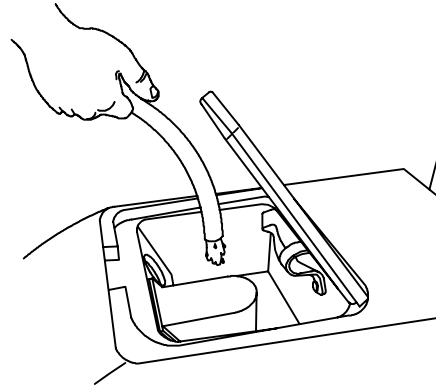

FIG. 31

- Turn ES switch on when ready to begin scrubbing. The ES indicator light will automatically turn on when recovery tank reaches its recycling level (Figure 32).

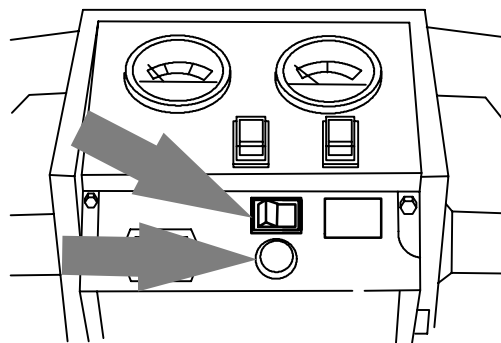

FIG. 32

NOTE: If ES indicator light remains on, drain tanks and clean ES filter located in recovery tank.

- Drain and flush recovery and solution tanks as needed (See DRAINING TANKS).

WHILE OPERATING MACHINE

⚠ WARNING: Fire Or Explosion Hazard. Do Not Pick Up Flammable Materials Or Reactive Metals.

1. Overlap each path by 50 mm (2 in.).
2. Keep machine moving to prevent damage to finish or floor.
3. Avoid floor obstructions, such as grates, to prevent pad damage.

FOR SAFETY: When using machine, go slow on inclines and slippery surfaces.

4. Periodically observe recovery tank for excessive foam. Pour a recommended foam control solution into recovery tank if excessive foam appears.

ATTENTION: Do not allow foam to enter float shut-off screen, vacuum motor damage will result; not covered by warranty. Foam will not activate float shut-off screen.

5. For heavily soiled areas, double scrubbing is recommended. First scrub area with squeegee up, let solution set for 15-20 minutes, then scrub area a second time with squeegee down.

ATTENTION: Do not operate machine with pad pressure meter in red zone, circuit breakers will trip and floor damage may occur.

6. Change or turn pads over when worn.
7. If squeegee leaves streaks, raise and wipe blades with a cloth. Pre-sweep area to prevent streaking.
8. Observe battery discharge indicator. When needle drops to the red zone, stop scrubbing and recharge batteries (Figure 33).

ATTENTION: Do not operate machine with battery discharge indicator in this red zone, battery damage will result.

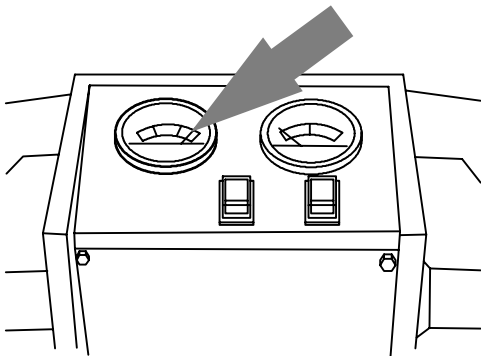

FIG. 33

9. ES SCRUBBING: Drain tanks and clean ES filter if ES indicator light remains on.

CIRCUIT BREAKERS

The machine is equipped with three resettable circuit breakers. They are designed to stop current flow in the event of a circuit overload. If a circuit breaker should trip during operation, determine the cause, allow breaker to cool and then manually reset the circuit breaker button. Circuit breaker panel is located at rear of machine (Figure 34).

- 7 A Main Circuit Breaker
- 17 A Vacuum Motor Circuit Breaker
- 35 A Brush Motor Circuit Breaker

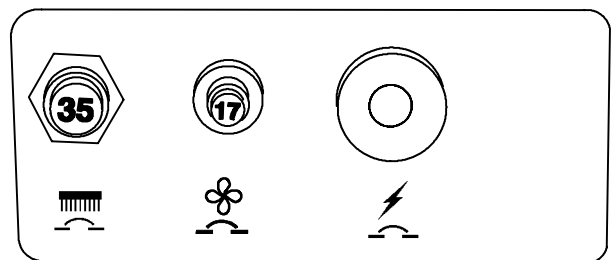

FIG. 34

OPERATING OFF-AISLE WAND (OPTION)

The off-aisle wand allows you to scrub/vacuum areas that the machine is unable to reach.

1. Turn machine power off.

FOR SAFETY: Before leaving or servicing machine, stop on level surface, and turn off machine.

2. Disconnect squeegee vacuum hose from squeegee assembly (Figure 35).

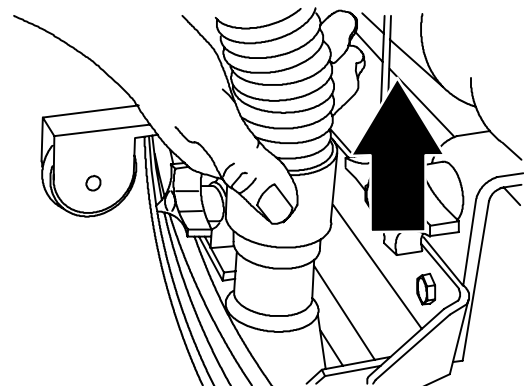

FIG. 35

OPERATION

3. Connect wand's vacuum hose using hose adapter supplied with wand (Figure 36).

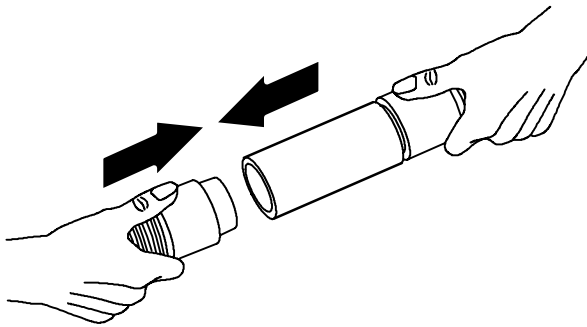

FIG. 36

4. If machine is equipped with Off-Aisle Wand Pump option, connect solution hose to quick disconnect coupler located behind left wheel (Figure 37).

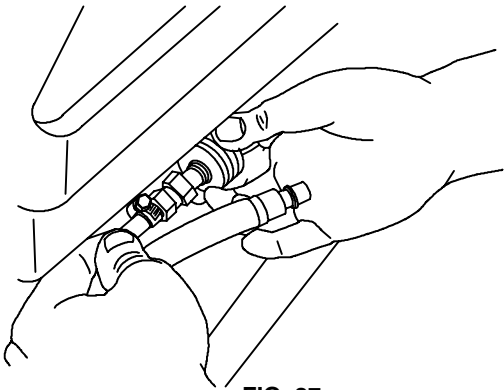

FIG. 37

5. Attach vacuum hose and solution hose to wand (Figure 38).

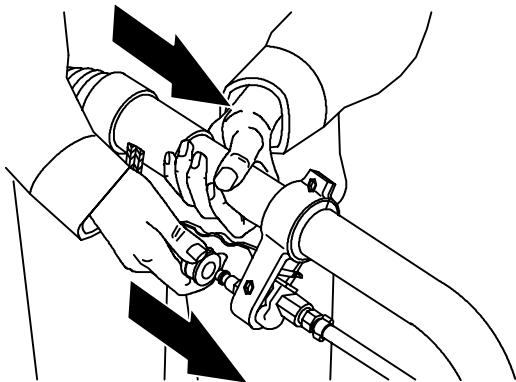

FIG. 38

6. Turn machine power and wand pump switch on (Figure 39).

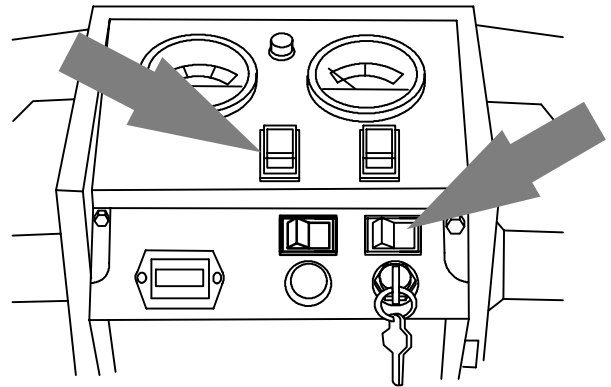

FIG. 39

7. Lower squeegee to turn on vacuum system (Figure 40).

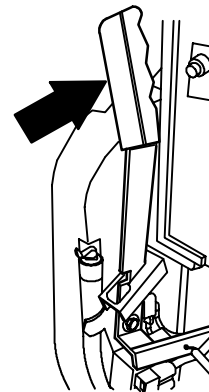

FIG. 40

8. Squeeze lever on wand and spray solution on floor. Scrub floor with brush side of wand and vacuum up solution with squeegee side of wand (Figure 41).

⚠ WARNING: Fire Or Explosion Hazard. Do Not Pick Up Flammable Materials Or Reactive Metals.

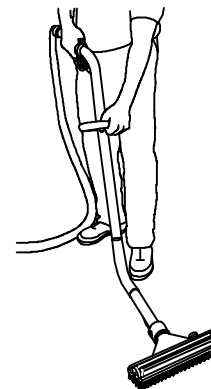

FIG. 41

9. Hard Floor Wand Option: If wand is hard to push, or has poor pick up, turn black adjustment knob to adjust roller wheel (Figure 42).

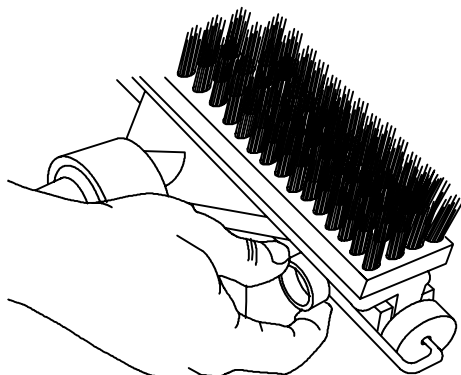

FIG. 42

10. When finished, turn off machine power and wand pump switch, and raise squeegee to shut off vacuum system. Disconnect hoses and reattach squeegee hose.

DRAINING TANKS

The recovery tank must be drained and cleaned out after every use.

The solution tank should be cleaned out periodically to remove any corrosion. When using the ES option, the solution tank must be drained and cleaned out after every use.

Transport the machine to a draining site, turn the machine off and follow the draining instructions below:

FOR SAFETY: Before leaving or servicing machine, stop on level surface and turn off machine.

DRAINING RECOVERY TANK

1. Remove recovery tank drain hose from hose hook (Figure 43).

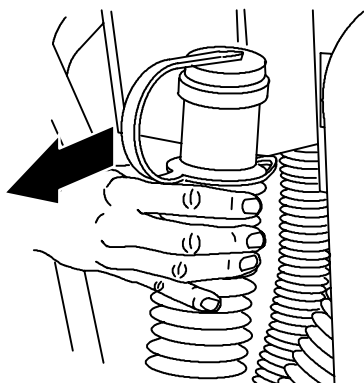

FIG. 43

2. Remove the drain hose cap while holding the hose up, then slowly lower the drain hose to the floor drain or sink (Figure 44).

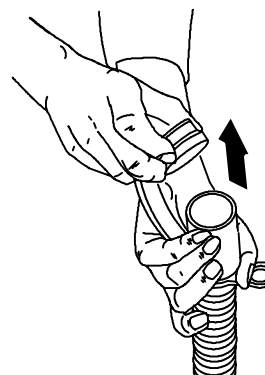

FIG. 44

NOTE: If using a bucket to drain machine, do not use same bucket for filling solution tank. This will prevent possible solution line clogs.

3. Flush out inside of recovery tank with clean water (Figure 45).

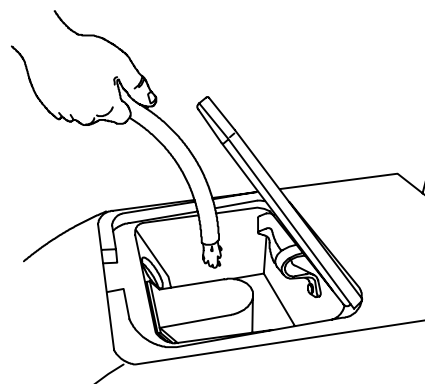

FIG. 45

4. Remove and rinse off the float shut-off screen located in recovery tank (Figure 46).

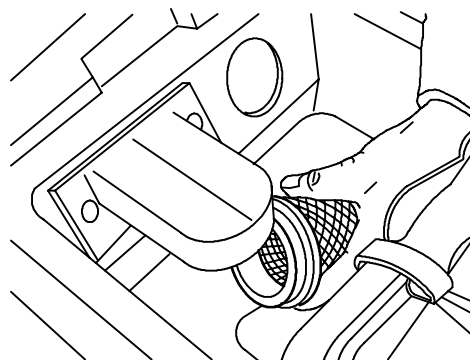

FIG. 46

OPERATION

5. If equipped with ES option, remove ES filter from recovery tank and clean (Figure 47).

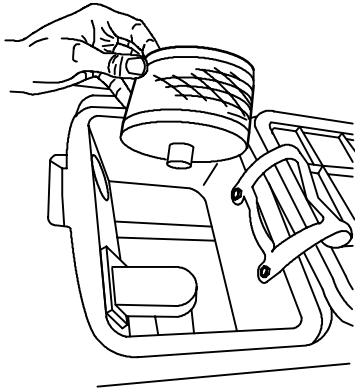

FIG. 47

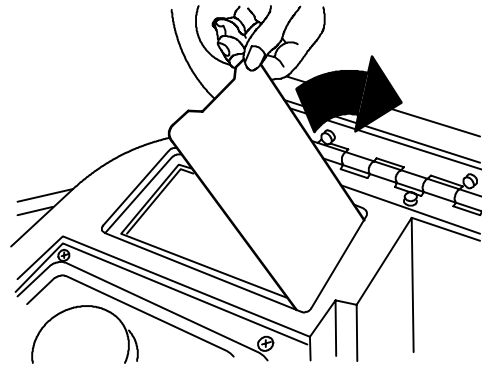

FIG. 50

DRAINING SOLUTION TANK

1. Remove solution tank drain hose from hose clip (Figure 48).

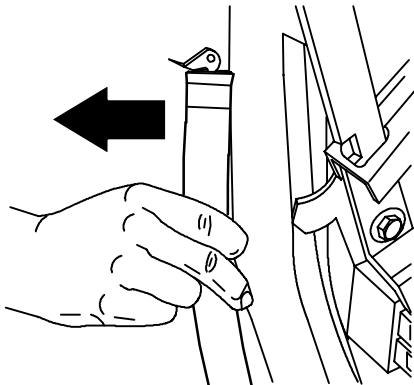

FIG. 48

2. Release retainer tab on hose plug and pull out plug while holding hose up, then slowly lower the drain hose to the floor drain (Figure 49).

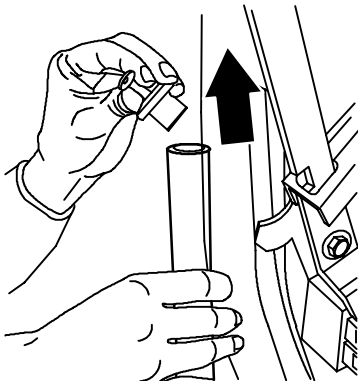

FIG. 49

4. ES option: Hinge open recovery tank to access solution tank. Lift solution tank cover and flush out solution tank with clean water. Rinse filter at bottom of solution tank (Figure 50).

CHARGING BATTERIES

ATTENTION: To prolong the life of the batteries and to provide optimum machine performance, **ONLY** recharge the batteries after a total of 30 minutes of use or more. Do not leave batteries discharged for lengthy periods.

The following charging instructions are intended for battery chargers supplied with the machine. Only use a battery charger with the following specifications to prevent battery damage.

BATTERY CHARGER SPECIFICATIONS:

- CHARGER TYPE: FOR LEAD ACID BATTERIES
- OUTPUT VOLTAGE - 24 VOLTS
- OUTPUT CURRENT - 12 AMPS for 130 AH Batteries
- OUTPUT CURRENT - 20 AMPS for 215 AH Batteries
- AUTOMATIC SHUTOFF CIRCUIT
- FOR DEEP CYCLE BATTERY CHARGING

1. Transport the machine to a well ventilated area for charging.

⚠ WARNING: Fire Or Explosion Hazard. Batteries Emit Hydrogen Gas. Keep Sparks And Open Flame Away. Keep Battery Compartment Open When Charging.

2. Park the machine on a level surface and turn the machine off.
3. Before charging the batteries, check the electrolyte level in each battery cell.

FOR SAFETY: When servicing machine, wear protective gloves and eye protection when handling batteries or battery cables. Avoid contact with battery acid.

The electrolyte level (A) should slightly cover the battery plates (B). Add distilled water as needed. DO NOT OVERFILL, the fluid may expand and overflow while charging. Replace cell caps before charging (Figure 51).

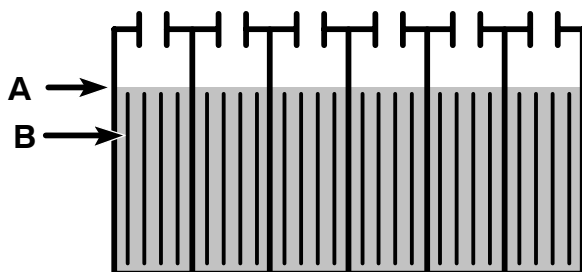

FIG. 51

- Rest the recovery tank on the support stand to promote ventilation during charging (Figure 52).

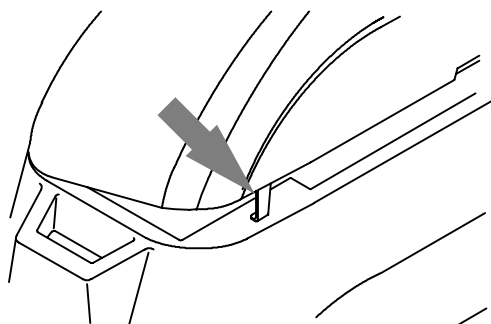

FIG. 52

- Connect the charger's AC power supply cord to a properly grounded receptacle (Figure 53).

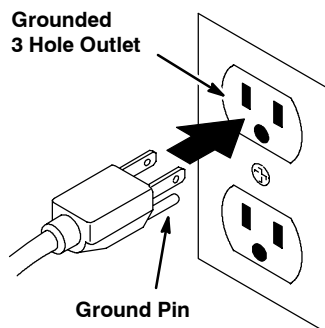

FIG. 53

- Connect the charger's DC cord to the machine's battery receptacle at the rear of the machine (Figure 54).

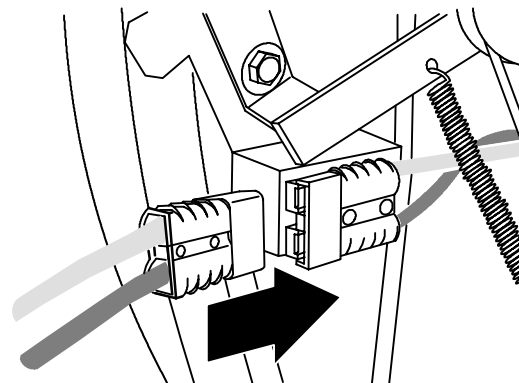

FIG. 54

- The charger will automatically begin charging and shut off when fully charged.

NOTE: The machine will not operate once the battery charger is connected.

ATTENTION: Do not disconnect the charger's DC cord from the machine's receptacle when the charger is operating. Arcing may result. If the charger must be interrupted during charging, disconnect the AC power supply cord first.

⚠ WARNING: Fire Or Explosion Hazard. Batteries Emit Hydrogen Gas. Keep Sparks And Open Flame Away. Keep Battery Compartment Open When Charging.

- After charging, check the electrolyte level (A) again. The level should be approximately 1 cm from the bottom of the fill-port (B) (Figure 55). Add distilled water if needed. DO NOT OVERFILL.

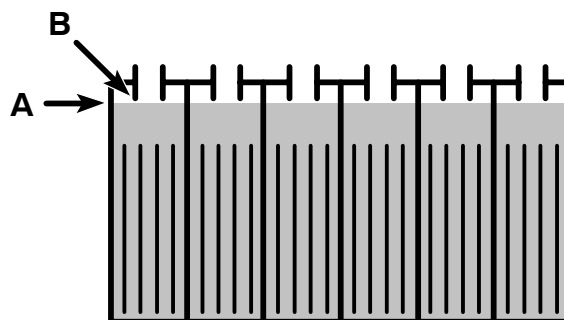

FIG. 55

OPERATION

BATTERY DISCHARGE INDICATOR

Battery discharge indicator shows charge level of batteries. The needle should be far right of green zone when batteries are fully charged. As batteries are discharged, the needle will move to the left red zone. Recharge batteries when needle reaches the red zone (Figure 56).

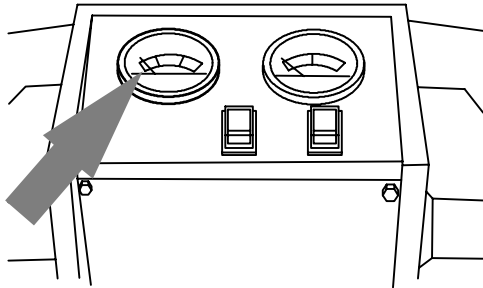

FIG. 56

MACHINE MAINTENANCE

To keep the machine in good working condition, simply follow the daily, monthly and quarterly maintenance procedures.

FOR SAFETY: Electrical Hazard. Disconnect Battery Cables Before Servicing Machine.

DAILY MAINTENANCE

1. Drain and clean out the recovery tank (Figure 57).

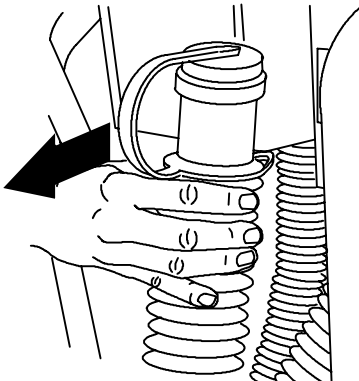

FIG. 57

2. Remove and clean the float shut-off screen located in the recovery tank (Figure 58).

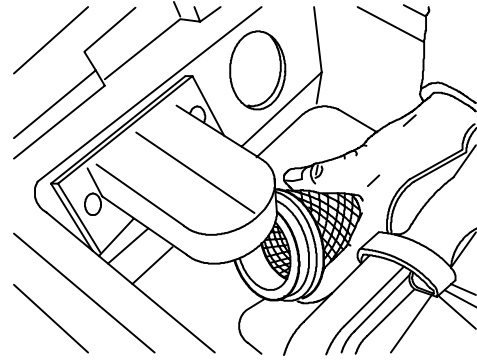

FIG. 58

3. If equipped with ES option, remove ES filter from recovery tank and clean (Figure 59).

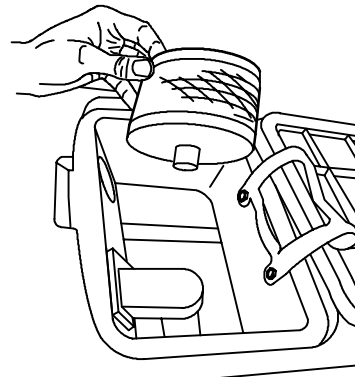

FIG. 59

4. If equipped with ES option, drain and rinse out the solution tank with clean water.
5. Remove and clean pads or brushes. Never use soiled pads when cleaning. Rotate pad or replace when worn (Figure 60).

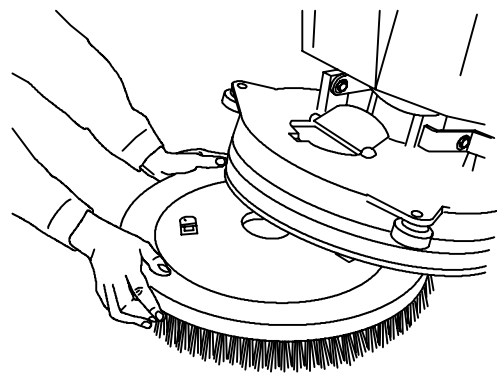

FIG. 60

6. Check scrub head skirt for wear. Replace if worn or damaged. Make sure skirt height is 1.5 mm (.062 in) from floor all away around scrub head with pad/brush installed (Figure 61).

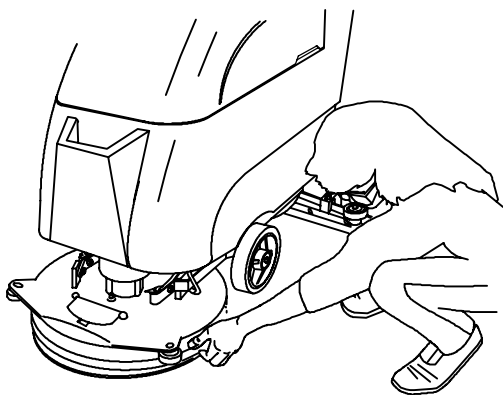

FIG. 61

7. Check squeegee blades for damage and wear. Wipe the squeegee blades clean. Store the squeegee assembly in the raised position to prevent blade damage (Figure 62).

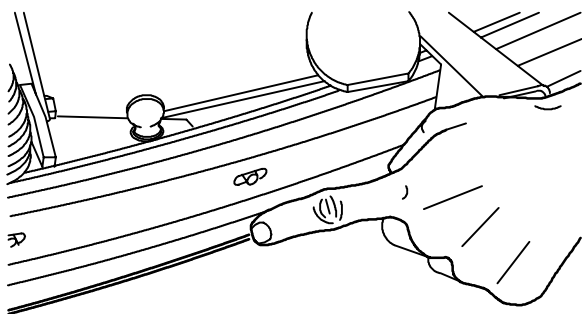

FIG. 62

8. Clean the machine with an all purpose cleaner and damp cloth (Figure 63).

FOR SAFETY: When cleaning machine, do not power spray or hose off machine. Electrical malfunction may occur.

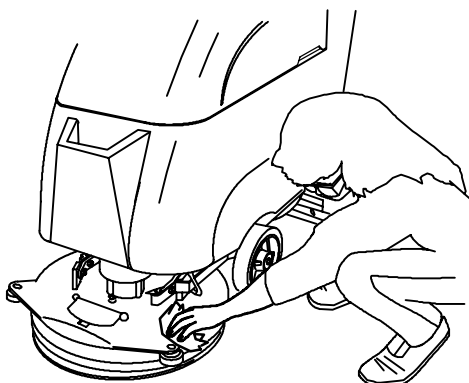

FIG. 63

9. Recharge the batteries after a total of 30 minutes of use or more (See CHARGING BATTERIES).

MONTHLY MAINTENANCE (Every 80 Hours of Use)

1. Flush solution system with a mixture of water and a recommended neutralizer liquid. Pour 11.3 L (3 gal) of clean water into solution tank, 60°C (140°F) maximum temperature. Add neutralizer liquid according to mixing instructions. Over a floor drain, briefly operate machine, ES option, and wand option for 30 seconds each. Turn machine off and leave machine sit overnight. Next day, disperse remaining mixture then rinse solution system with clean water.

NOTE: Contact your chemical supplier for a recommended neutralizer liquid.

⚠ WARNING: Flammable materials can cause an explosion or fire. Do not use flammable materials in tank(s).

FOR SAFETY: When using machine, follow mixing instructions on chemical containers.

2. Clean the battery tops to prevent corrosion (See BATTERY MAINTENANCE).
3. Check for loose battery cable connections.
4. Lubricate swivel caster grease fitting with a water resistant grease (Figure 64).

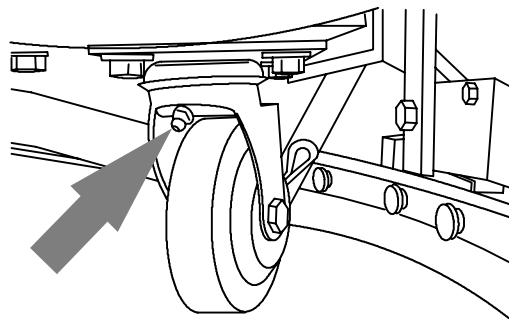

FIG. 64

5. Lubricate all pivot points and rollers with silicone spray then coat with a water resistant grease to maintain smooth operation.
6. Check the machine for loose nuts and bolts.
7. Check the machine for leaks.

OPERATION

QUARTERLY MAINTENANCE (Every 250 Hours of Use)

Check the vacuum motor and the brush motor for carbon brush wear. Replace carbon brushes when worn to a length of 10 mm or less.

Contact an Authorized Service Center for machine repairs.

⚠ WARNING: Electrical Hazard. Disconnect Battery Cables Before Servicing Machine.

BATTERY MAINTENANCE

⚠ WARNING: Fire Or Explosion Hazard. Batteries Emit Hydrogen Gas. Keep Sparks And Open Flame Away. Keep Battery Compartment Open When Charging.

FOR SAFETY: When servicing machine, wear protective gloves and eye protection when handling batteries and battery cables. Avoid contact with battery acid.

1. Check the specific gravity using a hydrometer to determine the charge level and the condition of the batteries (Figure 65). If one or more of the battery cells read lower than the other battery cells (0.050 or more), the cell is damaged, shorted, or is about to fail. Check the hydrometer readings against the following chart to determine the remaining battery charge level.

NOTE: Do not take readings immediately after adding distilled water. If the water and acid are not thoroughly mixed, the readings may not be accurate.

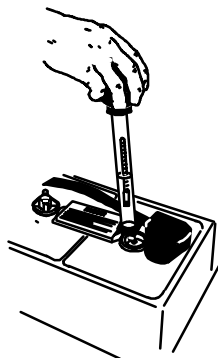

FIG. 65

SPECIFIC GRAVITY at 27° C	BATTERY CHARGE
1.265	100% CHARGED
1.223	75% CHARGED
1.185	50% CHARGED
1.148	25% CHARGED
1.110	DISCHARGED

NOTE: If the readings are taken when the battery electrolyte is any temperature other than 27° C (80° F), the reading must be temperature corrected. Add or subtract to the specific gravity reading 0.004, 4 points, for each 6° C (43° F) above or below 27° C (80° F).

2. Always follow proper charging instructions (See CHARGING BATTERIES).
3. Check the electrolyte level (A) in each battery cell **after charging batteries**. The level should be approximately 1 cm (.375 in) from the bottom of the fill-port (B). Add distilled water if needed (Figure 66) **DO NOT OVERFILL**.

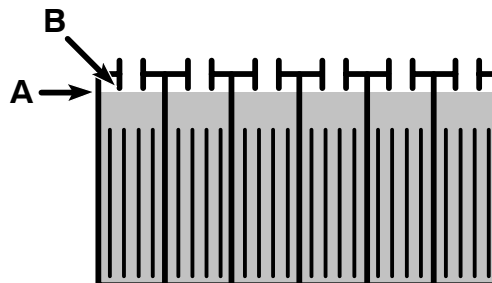

FIG. 66

4. Keep the battery tops clean to prevent battery corrosion.

To clean batteries:

FOR SAFETY: When servicing machine, wear protective gloves and eye protection when handling batteries and battery cables. Avoid contact with battery acid.

- a. Mix a strong solution of baking soda and water (Figure 67).



FIG. 67

- b. Brush the solution sparingly over the battery tops and cable connectors.

NOTE: Do not allow baking soda solution to enter battery cells.

- c. Use a wire brush to clean the battery terminals and cable connectors.
 - d. After cleaning, apply a coating of clear battery post protectant to the terminals and cable connectors.
5. Check for loose or worn cables. Replace if worn.

SQUEEGEE BLADE REPLACEMENT

Each squeegee blade has four wiping edges. When the blades become worn, simply rotate the blades end-for-end or top-to-bottom for a new wiping edge. Replace blade if all four edges are worn.

1. Remove the squeegee assembly from the machine.
2. To remove front squeegee blade, unthread six thumbscrews and remove retainer band and squeegee blade from squeegee frame (Figure 68).

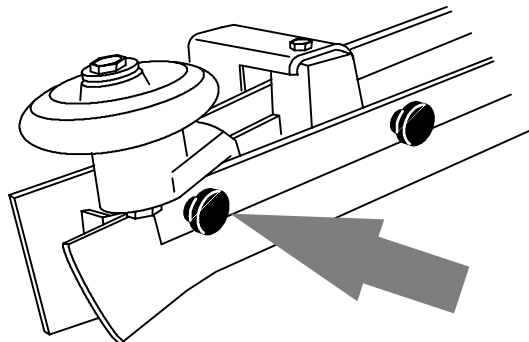

FIG. 68

3. Replace or rotate blade end for end to allow a new edge to face forward.
4. Replace retainer band and secure with six thumbscrews.
5. To remove rear squeegee blade, unlatch retainer clamp and remove retainer band and squeegee blade from squeegee frame (Figure 69).

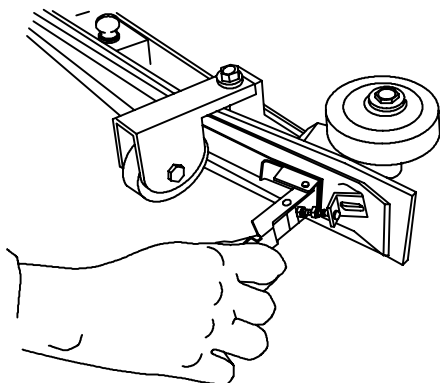

FIG. 69

6. Replace or rotate blade end for end to allow a new edge to face forward.
7. Replace retainer band and secure with clamp.
8. Check squeegee for proper deflection (See LEVELING SQUEEGEE).

SCRUB HEAD SKIRT REPLACEMENT

1. Turn machine power off.

FOR SAFETY: Before leaving or servicing machine, stop on level surface and turn off machine.

2. Raise scrub head.
3. Loosen skirt band clamp and remove clamp from band. Remove old skirt and band from scrub head (Figure 70).

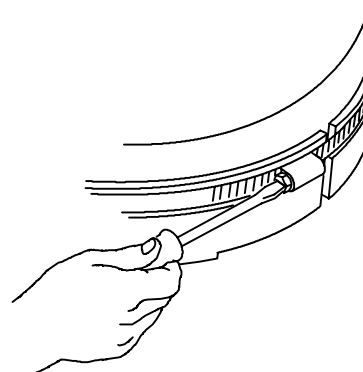

FIG. 70

4. Route skirt band through new skirt, place skirt on scrub head and replace screw clamp. Make sure clamp is at rear of scrub head.
5. Slightly tighten skirt band screw clamp to allow for easy hand adjustment (Figure 71).

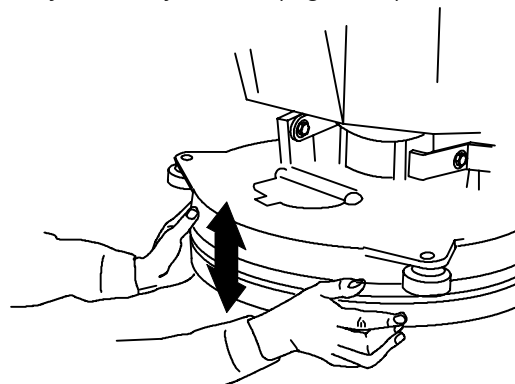

FIG. 71

6. Adjust skirt height (See ADJUSTING SCRUB HEAD SKIRT HEIGHT).

OPERATION

MACHINE JACKING

Use designated location on machine frame for jacking up machine. Once jacked up, block machine frame up with jack stands to secure machine (Figure 72).

Always jack machine on a flat level surface and block machine tires before jacking up machine.

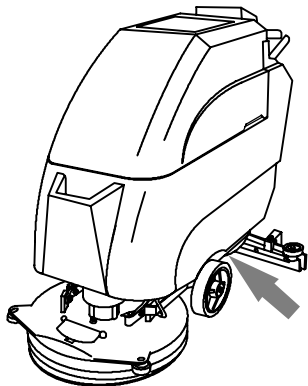

FIG. 72

FOR SAFETY: When servicing machine, block machine tires before jacking machine up. Jack machine up at designated locations only. Block machine up with jack stands. Use hoist or jack of adequate capacity to lift machine.

TRANSPORTING MACHINE

When transporting the machine by use of a trailer or truck, be certain to follow the tie-down procedures below:

FOR SAFETY: When using machine, go slow on inclines and slippery surfaces.

1. Remove squeegee assembly and brush/pad driver from machine.
2. Load machine using a recommended loading ramp. Use assistance or winch when ramp loading machine.
3. Position the front of machine up against the front of the trailer or truck. Once the machine is positioned, lower the scrub head and squeegee, if left installed.
4. Place a block behind each main wheel to prevent machine from rolling.
5. Place tie-down straps over the top of machine to prevent it from tipping. It may be necessary to install tie-down brackets to the floor of your trailer or truck.

NOTE: Do not use control grips to secure machine for transporting.

FOR SAFETY: When transporting machine, use a recommended ramp when loading/unloading into/off truck or trailer. Use tie-down straps to secure machine to truck or trailer.

STORING MACHINE

1. Charge batteries before storing. Never store machine with discharged batteries.
2. Drain and rinse the tanks thoroughly.
3. Store the machine in a dry area with the squeegee and scrub head in the up position.
4. Open the recovery tank cover to promote air circulation.

ATTENTION If storing machine in freezing temperatures, be certain to drain machine of all water. Damage due to freezing temperatures is not covered by warranty.

ATTENTION: Do not expose machine to rain, store indoors.

RECOMMENDED STOCK ITEMS

Refer to the Parts List section for recommended stock items. Stock Items are clearly identified with a bullet preceding the parts description. See example below:

Ref.	Part No.	Description	Qty.
1	701100	ASSEMBLY, STANDPIPE	1
2	180613	• FLOAT, SHUTOFF	1
3	230187	NIPPLE	1
4	101714	• GASKET	1
5	210240	NUT, FLANGED	1

TROUBLESHOOTING

PROBLEM	CAUSE	SOLUTION
Machine will not operate.	Faulty machine power switch.	Contact Service Center.
	Batteries need charging.	See CHARGING BATTERIES.
	Faulty battery(s).	Replace battery(s).
	Loose battery cable.	Tighten loose cable.
	MAIN circuit breaker has tripped.	Determine cause and reset breaker.
Brush motor will not operate.	Faulty roll switch in console.	Contact Service Center.
	Control grips not rotated.	Rotate grips.
	Brush circuit breaker has tripped.	Replace pad or adjust pad pressure and reset brush circuit breaker button.
	Faulty brush motor or wiring.	Contact Service Center.
	Worn carbon brushes.	Contact Service Center.
	Faulty switch on head lift bracket.	Contact Service Center.
Vacuum motor will not operate.	Faulty switch on squeegee lift arm.	Contact Service Center.
	Squeegee is raised off floor.	Lower squeegee.
	Main circuit breaker has tripped.	Remove obstruction and reset circuit breaker button.
	Vacuum motor circuit breaker has tripped.	Determine cause and reset circuit breaker button.
	Faulty vacuum motor or wiring.	Contact Service Center.
	Worn carbon brushes.	Contact Service Center.
Little or no solution flow.	Solution switch is not activated.	Turn solution switch on.
	Control grips not rotated.	Rotate grips.
	Clogged solution line or solution tank filter.	Remove hose and blow compressed air through it. Flush solution tank after each use.
	Clogged solution valve or solenoid.	Remove valve or solenoid and clean. Do not scratch inside of valve.
	Faulty solution switch or solenoid.	Contact Service Center.
	Solution flow knob not activated.	Turn solution flow knob.
	Loose set screw on solution knob.	Calibrate knob and tighten screw.
	Broken solution control cable.	Replace cable.
	Faulty switch on head lift bracket.	Contact Service Center.
Poor scrubbing performance.	Worn or improper brush/pad.	Replace brush/pad.
	Debris caught in brush/pad.	Remove debris.
	Tripped brush motor circuit breaker.	Reset circuit breaker.
	Low battery charge.	Charge batteries.
	Incorrect brush/pad pressure.	Readjust brush/pad pressure.

OPERATION

TROUBLESHOOTING - continued

Poor water pickup.	Recovery tank is full.	Empty recovery tank.
	Foam filling recovery tank.	Empty recovery tank.
	Clogged float shut-off screen inside recovery tank.	Remove screen and clean.
	Clogged squeegee.	Clean squeegee.
	Worn squeegee blades.	Replace squeegee blades.
	Loose vacuum hose connections.	Push hose cuffs firmly on connections.
	Clogged vacuum hose.	Remove clogged debris.
	Damaged vacuum hose.	Replace damaged hose.
	Recovery tank inlet hole is obstructed.	Empty recovery tank and tilt tank sideways to access inlet hole, remove obstruction.
	Worn gasket on recovery tank cover.	Replace gasket.
	Loose drain hose plug.	Tighten plug.
	Recovery tank cover not in place.	Properly position cover.
	Battery charge level is low.	Charge batteries. Do not run machine when battery meter is in the red zone.
ES option will not operate.	ES ON/OFF switch not activated.	Turn ES switch on.
	ES filter is clogged.	Remove and clean ES filter.
	Faulty ES pump.	Contact Service Center.
	Faulty ES ON/OFF switch.	Contact Service Center.
	ES float switch is clogged.	Rinse off float switch located in recovery tank.
	Faulty ES float switch.	Contact Service Center.
Short run time.	Batteries not fully charged.	Charge batteries.
	Faulty Battery(s).	Replace battery.
	Batteries need maintenance.	See BATTERY MAINTENANCE.
	Faulty charger.	Replace charger.
	Excessive brush/pad pressure.	Properly adjust pressure.

SPECIFICATIONS

MODEL	5280
LENGTH	1181 mm (46.5 in)
WIDTH	546 mm (21.5 in)
HEIGHT	984 mm (38.75 in)
WEIGHT	93 Kg (205 lb) without batteries
RECOVERY TANK CAPACITY	49 L (13 Gal)
SOLUTION TANK CAPACITY	45 L (12 Gal)
ES OPTION SOLUTION FILL CAPACITY	64 L (17 Gal)
CLEANING RATE	1908 m ² per hour (20,536 sq ft)
CLEANING PATH WIDTH	508 mm (20 in)
PAD PRESSURE	Variable 18–32 Kg (40–70 lb)
BRUSH PRESSURE	Variable 20–39 Kg (45–85 lb)
SQUEEGEE WIDTH	724 mm (28.5 in)
TOTAL POWER CONSUMPTION	30–35 Amp nominal
BRUSH MOTOR	0.56 Kw (0.75 hp), 200 rpm, 24 V, 33 A
VACUUM MOTOR	0.56 Kw (0.75 hp), 2-stage 5.7 in, 24 V, 15 A
WATER LIFT	1140 mm (45 in)
BATTERIES	Two - 12 V, 130 AH, 32 Kg (70 lb ea.)
BATTERY CHARGER	24 VDC, 12 Amp, 60 Hz, 120 VAC
RUN TIME PER CHARGE	Up to 3 hours
DECIBEL RATING AT OPERATOR'S EAR, INDOORS ON TILE.	71 dB(A)

MACHINE DIMENSIONS

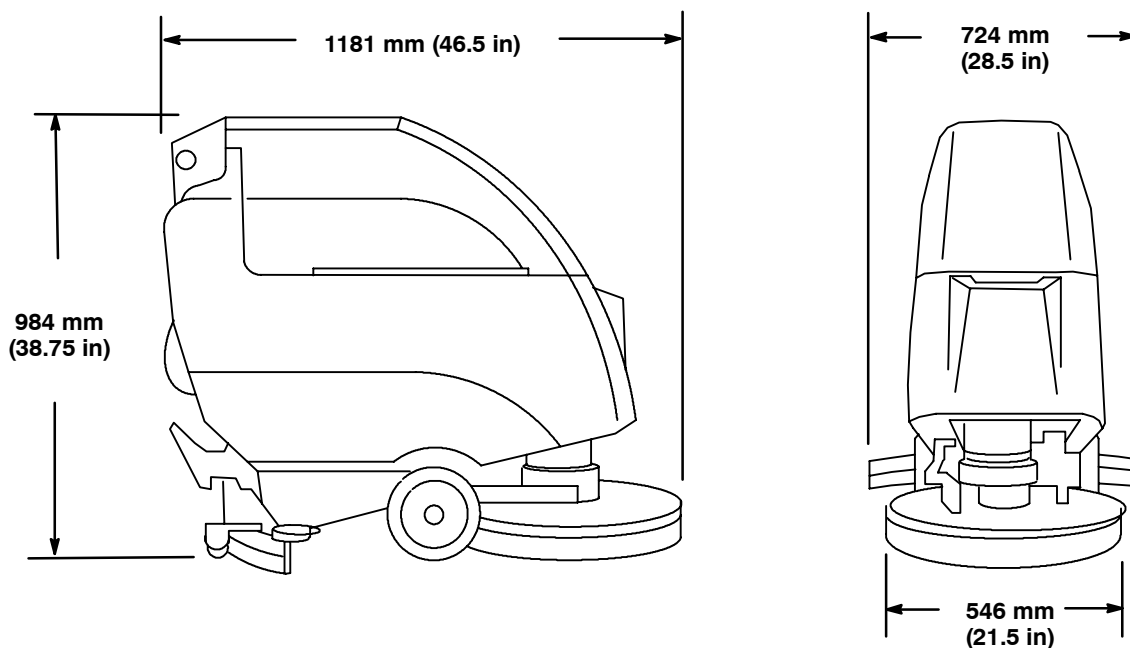

LADDER DIAGRAM

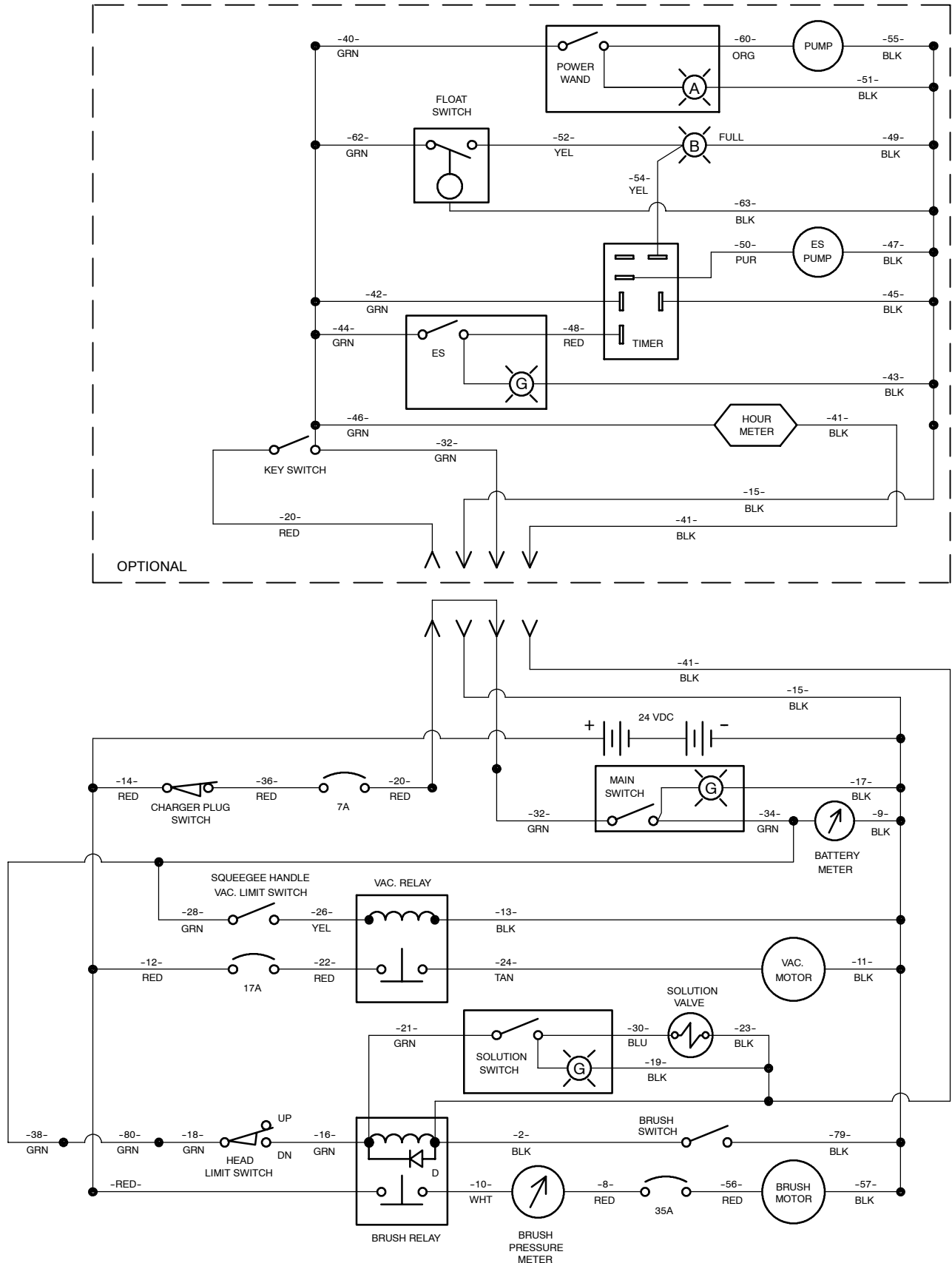

REPLACEMENT BRUSHES AND PAD DRIVER GROUP

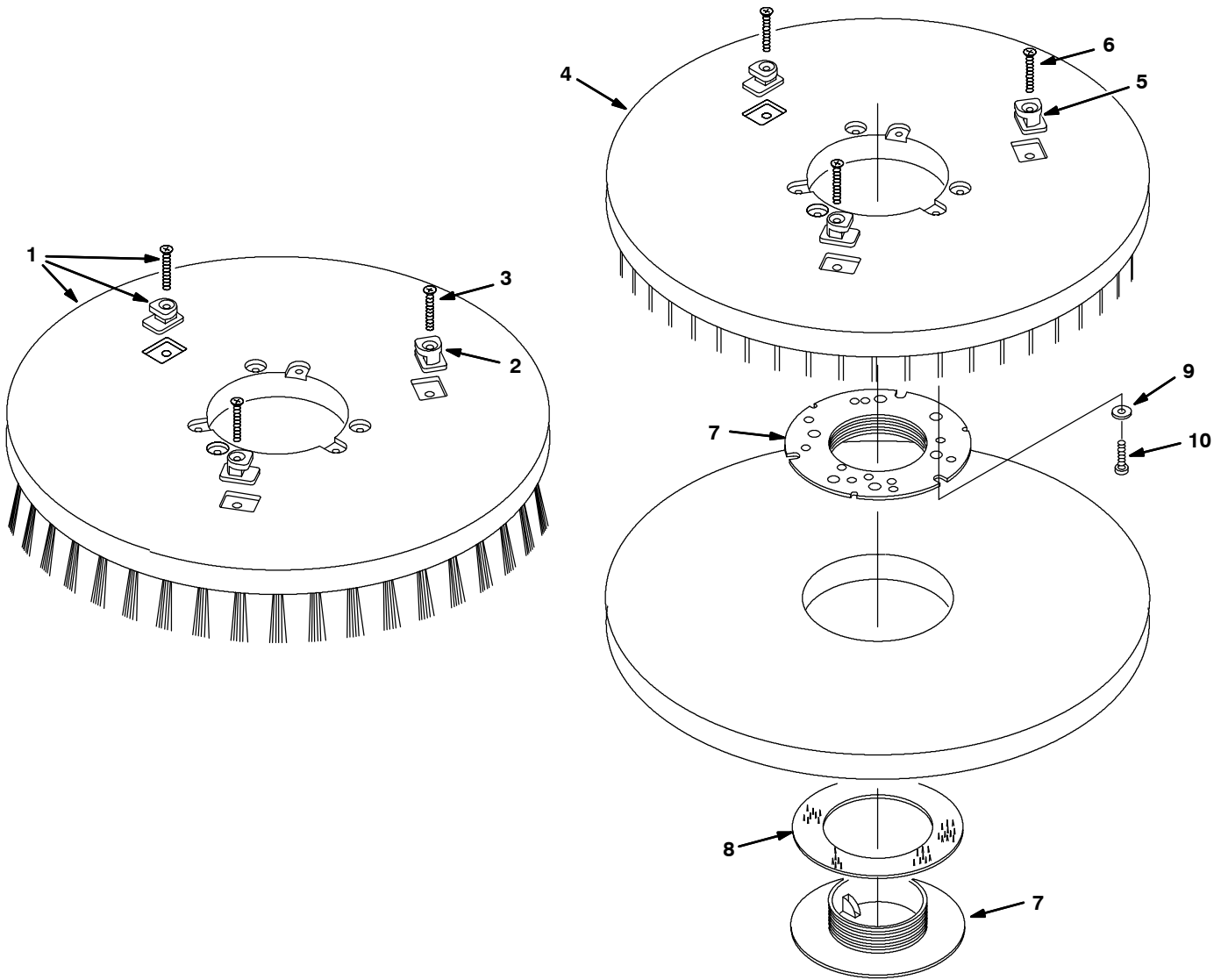

REPLACEMENT BRUSHES AND PAD DRIVER GROUP

REF	PART #	DESCRIPTION	QTY.
∇ 1	222301	BRUSH ASSY, DISK, SCB, 20.0D, NYLON	1
▲ 2	630214	●STUD, PLASTIC BRUSH	3
▲ 3	66016	SCREW, FLT, M6X1.0X40, 4.8	3
∇ 1	222300	BRUSH ASSY, DISK, SCB, 20.0D, POLYPROPYLENE	1
▲ 2	630214	●STUD, PLASTIC BRUSH	3
▲ 3	66016	SCREW, FLT, M6X1.0X40, 4.8	3
∇ 1	222302	BRUSH ASSY, DISK, SCB, 20.0D, ABRASIVE GRIT	1
▲ 2	630214	●STUD, PLASTIC BRUSH	3
▲ 3	66016	SCREW, FLT, M6X1.0X40, 4.8	3

REF	PART #	DESCRIPTION	QTY.
∇ 4	222303	●DRIVER ASSY, PAD, 20D, BRUSH	1
▲ 5	630214	●STUD, PLASTIC BRUSH	3
▲ 6	66016	SCREW, FLT, M6X1.0X40, 4.8	3
▲ 7	32506	●PAD, HOLDER	1
▲ 8	32505	WASHER, 3.60B 5.65D .06 BRUSH PAD	1
▲ 9	41579	WASHER, FLAT, #08 SS	3
▲ 10	04403	SCREW, PAN, M4X0.7X25, SS, NL	3

∇ ASSEMBLY

▲ INCLUDED IN ASSEMBLY

● RECOMMENDED STOCK ITEMS

SOLUTION TANK AND VACUUM MOTOR GROUP

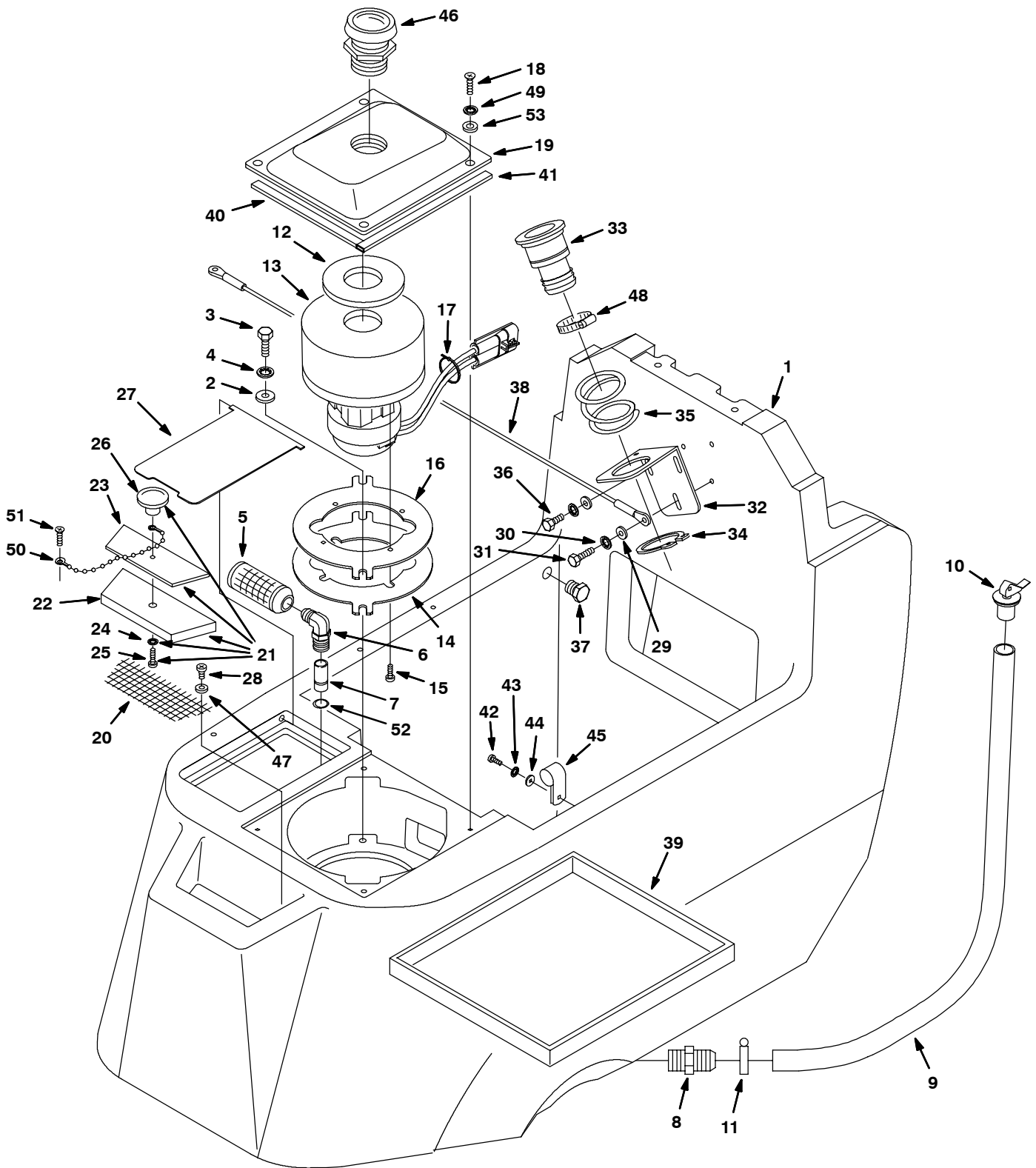

SOLUTION TANK AND VACUUM MOTOR GROUP

REF	PART #	DESCRIPTION	QTY.
1	602698	TANK, SOLTN, RM-TL	1
2	32491	WASHER, FLAT, 0.31 STD	2
3	16931	SCREW, HEX, M8X1.25X20, 8.8	2
4	200370019	WASHER, LOCK, M8.4 ZN	2
5	630024	●FILTER, SCREEN 060 MESH SS	1
6	630371	FITTING, PLSTC, E90, BM08/BM10	1
7	601105	SPACER, .50X.62X1.62 CPVC	1
8	612146000	FITTING, PVC, STR, PM12/BM12	1
9	630018	HOSE, 3/4ID X 33	1
10	630019	●PLUG, EXPANSION, .75ID	1
11	630369	CLAMP, HOSE, WORMDRIVE, 0.50-1.10D, .56W	1
12	102557	●GASKET, VAC MOTOR SEAL	1
13	607003	●FAN, VACUUM, 5.7D 2S 24VDC	1
	190163	●BRUSH CRBN, MOTOR, ELE, (1PC=1PACK=2BRSH)	1
14	630013	GASKET, BRKT, MOTOR, VAC 630014	1
15	140340	SCREW, PAN, #10-24X0.62, SS, TYP 25	4
16	630014	BRACKET, VAC MOTOR 20" SCRUBBER	1
17	130040	TIE, CABLE, NYL, 06.0L .12W	1
18	608322	SCREW, TRS, M6X1.0X16, PHL, SS	4
19	630015	COVER, VAC MOTOR, 20" SCRUBBER	1
20	630006	FILTER, SCREEN, SOL-FILL	1
▽ 21	630602	KIT, FILL COVER	1
▲ 22	630338	COVER, SOL FILL, 5300, NEO-PRENE	1
▲ 23	630341	STIFFENER, SOL FILL COVER	1
▲ 24	07514	WASHER, LOCK, INT, #10, SS	1
▲ 25	578201000	SCREW, PAN, #10-32X0.50, PHL, ZN	1
▲ 26	578301	KNOB, RND	1

▽ ASSEMBLY

▲ INCLUDED IN ASSEMBLY

● RECOMMENDED STOCK ITEMS

REF	PART #	DESCRIPTION	QTY.
27	630007	DOOR, ACCESS, TANK, SOLTN, 1/16 ABS	1
28	140872	SCREW, PAN, #06-32X0.38, ZN, HI-LO	2
29	579210	WASHER, FLAT, M6.4X18X1.5 ZN	3
30	578244000	WASHER, M6.4X10 LCK SS	3
31	08716	SCREW, HEX, M6X1.0X20, SS	1
32	630012	BRACKET, VAC TRANS MOUNT	1
33	630011	TUBE, VAC TRANS, FLANGE AND BARB	1
34	630016	RING, RETAINING EXT, 1.82D	1
35	630267	SPRING, CMPR, 59.9D, 3.0W, 50.8L MW ZN	1
36	200031436	SCREW, HEX, M6X1.0X16	2
37	630146	FITTING, PLUG, PM06, NYL	1
38	630021	CABLE ASSY, TANK SUPPORT, 20.5"	1
39	601991	TRAY, BATTERY	1
40	630380	KIT, GASKET 191MM FR VAC MTR COVER	2
41	630381	GASKET, 223MM, MOTOR, VAC	2
42	200070340	SCREW, PAN, M4X0.7X8, PHL, ZN	2
43	02938	WASHER, LOCK, INT, 08, SS	2
44	200301014	WASHER, M4.3X10.1X1 FLT ZN	2
45	630343	CLAMP, CABLE, STL, 0.88DX0.50W, 1H, VYL	2
46	630017	FILTER, SCREEN, VAC FAN, 20" SCRUB	1
47	140032	WASHER, #6 FLT SS	2
48	140308	CLAMP, HOSE, WORMDRIVE, 1.31-2.25D, SS	1
49	578244000	WASHER, M6.4X10 LCK SS	4
50	621443	CHAIN, BALL, #10X157L, SS	1
51	140826	SCREW, PAN, #06-32X0.75, PHL, SS SHTMTL	1
52	630508	SEAL, ORG, .070X.366ID	1
53	19066	WASHER, FLAT, #10	4

SOLUTION CONTROL GROUP

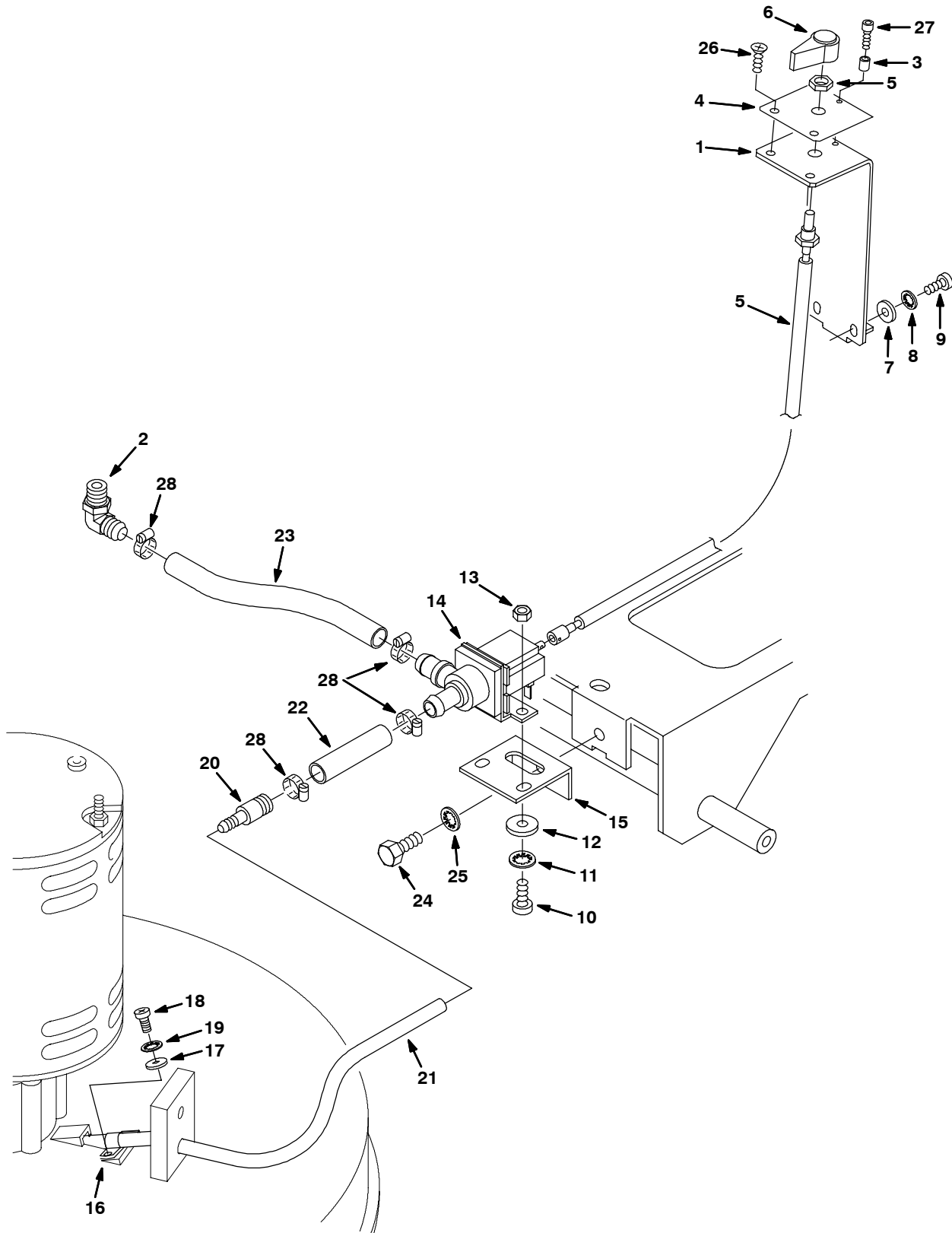

SOLUTION CONTROL GROUP

REF	PART #	DESCRIPTION	QTY.
1	630057	BRACKET, SOL. ADJ. KNOB 11GA, BR	1
2	1013505	FITTING, PLSTC, E90, PM08/BM08, NYL	1
3	630452	SPACER, 4.3X8.0X5.0 NY	1
4	630233	DECAL, FLOW CONTROL	1
5	630117	CABLE, WATER FLOW CONTROL, 44" LG	1
6	630116	KNOB, STAR, 1.25D 1EAR 0.6L .25-13 PLSTC	1
7	200315016	WASHER, FLAT, M5.3X15.0X1.6 ZN	2
8	07514	WASHER, LOCK, INT, #10, SS	2
9	575569000	SCREW, PAN, M5X0.8X16 PHL, DIN7985	2
10	608322	SCREW, TRS, M6X1.0X16, PHL, SS	2
11	578244000	WASHER, M6.4X10 LCK SS	2
12	19066	WASHER, FLAT, #10	2
13	579029	NUT, HEX, STD, M6X1.0 DIN 934P	2
14	630022	●VALVE, WATER, SOL, 24VDC 08BM/08BM	1
	614265	●KIT, VALVE, WATER, REBUILD	1

● RECOMMENDED STOCK ITEMS

REF	PART #	DESCRIPTION	QTY.
15	630059	BRACKET, VALVE 11GA CRS ZN	1
16	140328	CLAMP, CABLE, NYL, 0.38D, BLACK	1
17	200301014	WASHER, M4.3X10.1X1 FLT ZN	1
18	579259	SCREW, PAN, M4X0.7X12, PHL, ZN	1
19	02938	WASHER, LOCK, INT, 08, SS	1
20	630164	FITTING, PLSTC, STR, BM08/BM04	1
21	630366	HOSE, .25IDX345MM	1
22	613509	TUBING 1/2IDX3/4OD VINYL 611259 FT 0.16	1
23	613519	TUBING 1/2IDX3/4OD VINYL 611259 FT 0.710	1
24	16931	SCREW, HEX, M8X1.25X20, 8.8	1
25	200370019	WASHER, LOCK, M8.4 ZN	1
26	069764140	SCREW, FLT, M5X0.8X16, PHL, BO	2
27	200001343	SCREW, SOC, M4X0.7X12, ZN	1
28	54333	CLAMP, HOSE, WORMDRIVE, 0.31-0.88D, .31W	4

RECOVERY TANK GROUP

REF	PART #	DESCRIPTION	QTY.
1	610935	TANK, REC. RM-TL	1
2	200031486	SCREW, HEX, M8X1.25X16	1
3	140015	WASHER, LOCK, SPLT, 0.31 SS	1
4	140027	WASHER, FLAT, 0.35B 0.75D .04, SS	2
5	611418	SLEEVE, P/M, 0.437D 0.315B 0.14L STL PLT	1
6	606527	SUPPORT, TANK, RECVY	1
7	1014544	BUMPER, RBR	1
8	610979	CAP, PLUG 2" RED	1
9	630134	SEAL, ORG, 03.5MM X 16MM ID	1
10	630139	FITTING, PIPE, PLUG, BSP06 HEX	1
11	19066	WASHER, FLAT, #10	8
12	578244000	WASHER, M6.4X10 LCK SS	9
13	608322	SCREW, TRS, M6X1.0X16, PHL, SS	8
14	630048	HINGE, .25PIN .09 1.9W 18.0L, YLW ZN	1
15	140308	CLAMP, HOSE, WORMDRIVE, 1.31-2.25D, SS	1
16	200031436	SCREW, HEX, M6X1.0X16	1
▽ 17	1008639	●CAP, DRAIN ASSEMBLY	1
▲ 18	1008637	●O-RING, 1.48"ID, 1.76"OD	1
▲ 19	1019563	●STRAP, DRAIN CAP	1
20	630068	HOSE, DRAIN, 1.50ID X 32L	1

REF	PART #	DESCRIPTION	QTY.
21	059650283	WASHER, FLAT, M6.4X18X1.6 SS	2
22	600385	SCREW, PAN, M6X1.0X20, PHL, SS	2
23	578244000	WASHER, M6.4X10 LCK SS	2
24	630053	MOUNT, FLOAT-CAGE	1
▽ 25	613716	ASM, LID & LABEL	1
▲ 26	613287	LABEL, WARNING DC WB BRN/SCR/EXT 6X2.25	1
▲ 27	630367	●GASKET, COVER, TANK, RECVY, 33.75" LONG	1
28	1009168	WASHER, FLAT, 0.17B 0.75D .04 SS	4
29	630056	HINGE, COVER, TANK LID	1
30	140872	SCREW, PAN, #06-32X0.38, ZN, HI-LO	4
31	630147	FITTING, PLSTC, PLUG, PM12 HEX	1
32	630255	GASKET, FLOAT, MOUNT	1
33	630368	●GASKET, 650MM, RAC, VAC	1
34	610281	DECAL, MODEL "5280"	2
35	630229	LABEL, LOGO, TENNANT, OVAL, 257L, WHT	1
36	630010	●GASKET, 70OD, 43ID, 12.7THK	1
37	19066	WASHER, FLAT, #10	1
38	630052	●FLOAT, SHUT-OFF (2) BALL 1.75DIA	1
39	N/A	CAP, DRAIN ASSEMBLY - REPLACED BY ASSEM. ITEM #17	1

▽ ASSEMBLY

▲ INCLUDED IN ASSEMBLY

● RECOMMENDED STOCK ITEMS

CONSOLE GROUP

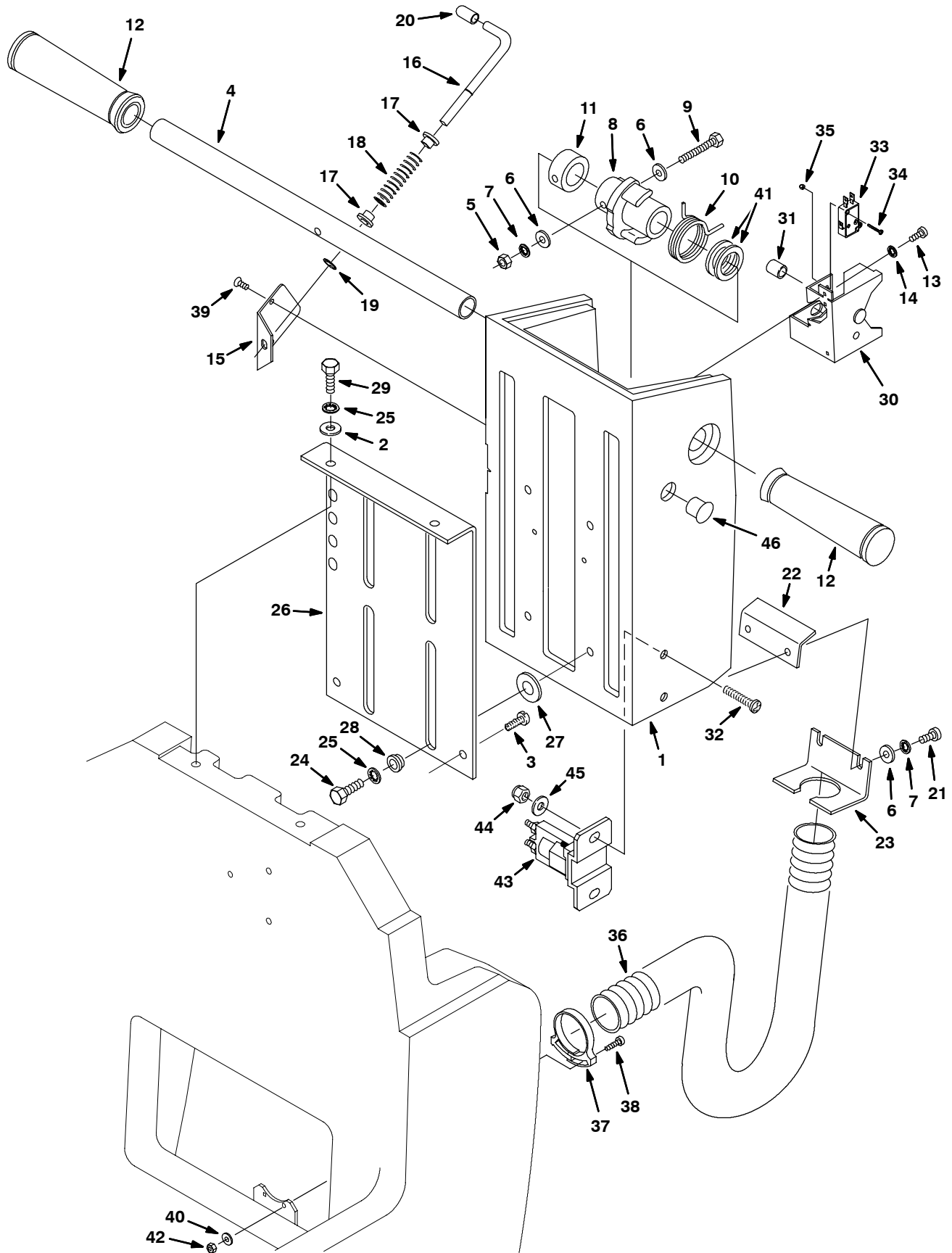

CONSOLE GROUP

REF	PART #	DESCRIPTION	QTY.
1	610922	CONT. HSG. TEAL	1
2	140027	WASHER, FLAT, 0.35B 0.75D .04, SS	2
3	630306	SCREW, FLT, M8X1.25X16, PHL, ZN	2
4	630093	HANDLE, BAR, .875"OD X 15.5"LG	1
5	579029	NUT, HEX, STD, M6X1.0 DIN 934P	1
6	579210	WASHER, FLAT, M6.4X18X1.5 ZN	4
7	578244000	WASHER, M6.4X10 LCK SS	3
8	630109	HUB/GEAR ASSY, 22.4ID, 20" SCR	1
9	630431	SCREW, HEX, M6X1.0X40, DIN933	1
10	630088	SPRING, TORS, CENTER, .072MW, ZN	1
11	630217	COLLAR, 1.38D 0.88B .63L	1
12	222648	GRIP, HANDLE, ROUND	2
13	200070340	SCREW, PAN, M4X0.7X8 PHL, ZN	2
14	02938	WASHER, LOCK, INT, 08, SS	2
15	630087	PLATE, LATCH, RETAINER	1
16	630081	LEVER, LATCH, CONSOLE ADJUST	1
17	630083	BUSHING, LATCH	2
18	630082	SPRING, CMPR, 10.7D 0.9W 44.4L MW ZN	1
19	630084	RING, RETAINING, EXT. 4.62MM	1
20	630094	CAP, VINYL, 2.26IDX12.7LG, BLK	1
21	608322	SCREW, TRS, M6X1.0X16, PHL, SS	2
22	630086	PLATE, STRAIN-RELIEF, 11GA ZN	1
23	630108	BRACKET, CONDUIT MOUNT, 16GA, ZP	1

REF	PART #	DESCRIPTION	QTY.
24	200031486	SCREW, HEX, M8X1.25X16	4
25	200370019	WASHER, LOCK, M8.4 ZN	6
26	582078	PLATE, CONSOLE SLIDE, 20" SCRUB	1
27	20536-2	WASHER, FLAT, 0.47B 1.19D .03, NYL	4
28	630095	BEARING, .38IDX.50ODX.25LG FLG	4
29	16931	SCREW, HEX, M8X1.25X20, 8.8	2
30	630079	BRACKET, LIMIT SWITCH MOUNT	1
31	630260	SPACER, 6.5X12.7X15.9 NY	1
32	15858.12	SCREW, FLT, #10-24X0.75, PHL, ZN	2
33	611006	●KIT, SWITCH REPLACEMENT	1
34	579213	SCREW, HEX, M3X.5X20, ZN	2
35	579211	NUT, HEX, LOCK, M3X.5, SS	2
36	630113	CONDUIT, CONVOLUTED, BLACK	1
37	140322	CLAMP, VACUUM HOSE PICKUP TOOL	1
38	578403000	SCREW, PAN, M3X0.5X20, PHL, ZN	2
39	630114	SCREW, FLT, M4X0.7X8, PHL, ZN	2
40	200301012	WASHER, FLAT, M3	2
41	069760582	WASHER, FLAT, M23X34X0.8, NYL	2
42	579211	NUT, HEX, LOCK, M3X.5, SS	2
43	603008	●RELAY, 24VDC, 100A, SP	1
44	140552	NUT, HEX, LOCK, #10-24, NL, SS	2
45	19324	WASHER, FLAT, #10 SAE	2
46	130280	PLUG, DOME, .437D, BLACK	1

● RECOMMENDED STOCK ITEMS

CONSOLE PANEL GROUP

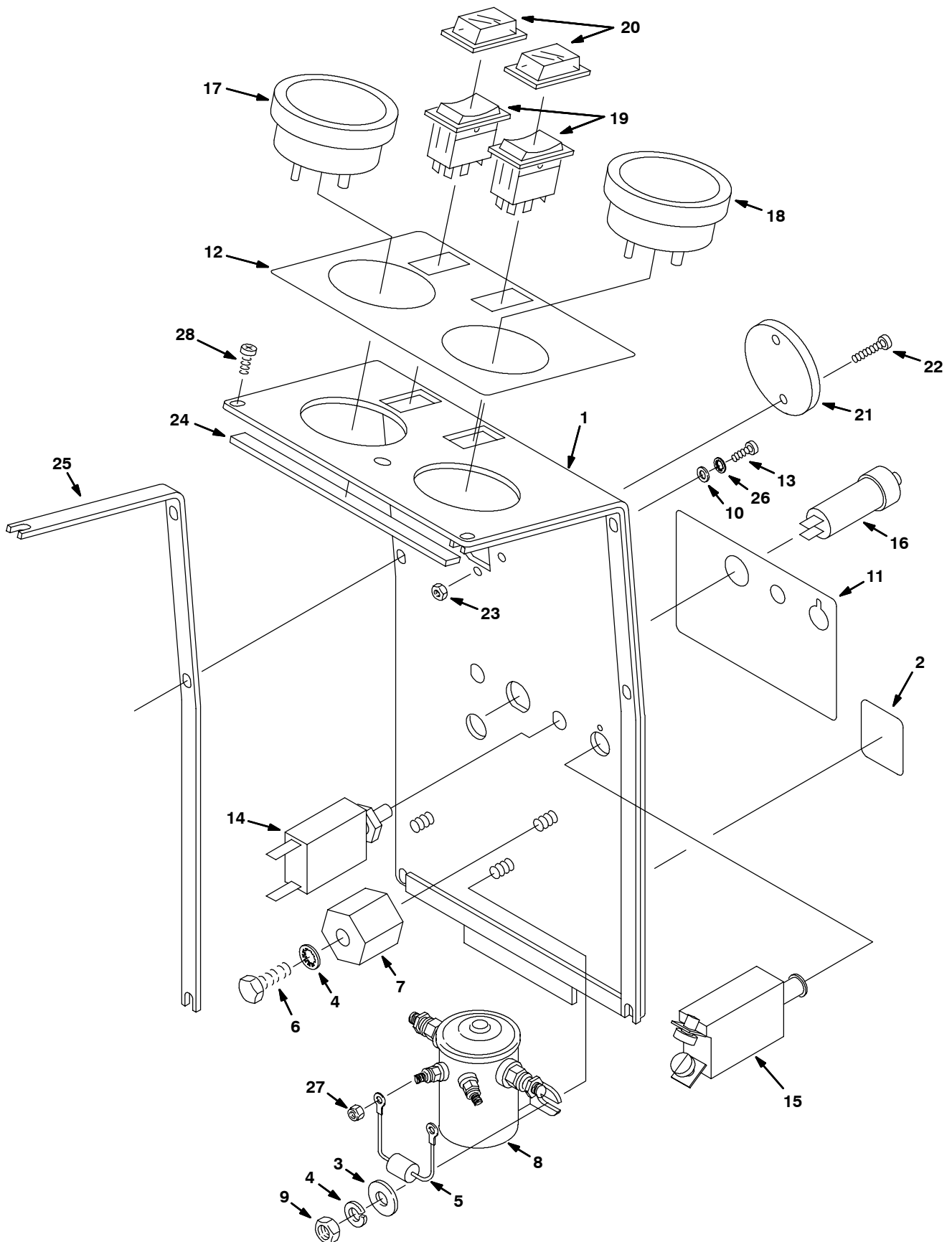

CONSOLE PANEL GROUP

REF	PART #	DESCRIPTION	QTY.
1	602477	PLATE SWITCH 20DC W/O CONTACTR	1
2	606105	LABEL, HZRD, DO NOT SPRAY	1
3	140000	WASHER, FLAT, 0.28B 0.62D .04, SS	2
4	578244000	WASHER, M6.4X10 LCK SS	3
5	606404	●DIODE, ASSY W/RING TERMINALS	1
6	069762115	SCREW, HEX, .25-20X0.50	1
7	76062	INSULATOR, PANEL & SWITCH- BOARD	1
8	605905	●SOLENOID, 24VDC 125A 050OHM	1
9	14501	NUT, 1/4-20 FULHEX ZN	2
10	200301014	WASHER, M4.3X10.1X1 FLT ZN	4
11	610282	DECAL, CIRC BRKR - 5280	1
12	610283	DECAL, CONSOLE - 5280	1
13	200070340	SCREW, PAN, M4X0.7X8, PHL, ZN	4
14	605201	●CIRCUITBREAKER, 17.0A 120VAC	1
15	602951	●CIRCUITBREAKER, 35.0A	1
16	630102	●CIRCUITBREAKER, 7.0A	1

● RECOMMENDED STOCK ITEMS

N/S = NOT SHOWN

REF	PART #	DESCRIPTION	QTY.
17	630090	●GAUGE, AMMETER, RND, 24VDC, 0-50A	1
18	630091	●GAUGE, DISCHARGE, BATTERY, 16-32VDC, RND	1
19	630419	●SWITCH, ROCKER, 28VDC A SPST	2
20	578720	●SPLASHGUARD, ROCKER SWITCH	2
21	607002	COVER PLATE 5300 BLACK WRINKLE	1
22	200070340	SCREW, PAN, M4X0.7X8, PHL, ZN	2
23	02850	NUT, HEX, LOCK, M4X0.7, NL	2
24	630453	GASKET, 143MM, FR CONSOLE, PANEL	2
25	630119	GASKET, CONSOLE 3.1X8.0X420	2
26	02938	WASHER, LOCK, INT, 08, SS	4
27	575380	NUT, HEX, STD, #10-32-2B, ZN	2
28	1009324	SCREW, PAN, #10-16X0.50, PHL, TY-17 BLK	4
N/S	607789	HARNESS, 5300 MAIN W/WATERPROOF	1
N/S	611028	ASM WIRE, #16X3GRN 1/4M-1/4M	1
N/S	611029	ASM WIRE, #18X19" BLK 1/4FX1/4R	1

MAIN FRAME GROUP

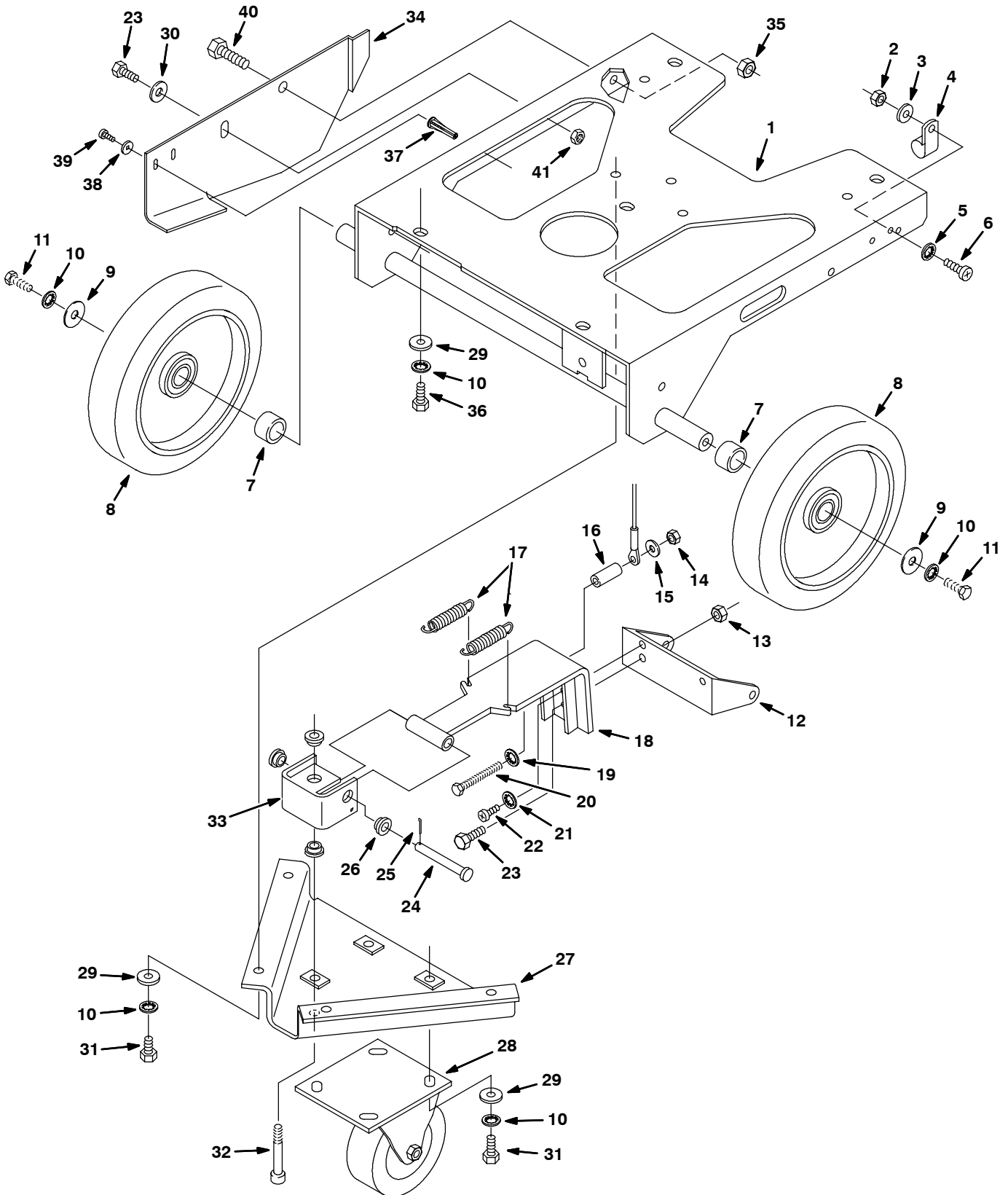

MAIN FRAME GROUP

REF	PART #	DESCRIPTION	QTY.
1	1013209	FRAME WLDT, MAIN, W/AXLE	1
2	579029	NUT, HEX, STD, M6X1.0 DIN 934P	1
3	579210	WASHER, FLAT, M6.4X18X1.5 ZN	1
4	630428	CLAMP, CABLE, STL, 1.0DX.50W, .25 MOUNT	1
5	578244000	WASHER, M6.4X10 LCK SS	1
6	608322	SCREW, TRS, M6X1.0X16, PHL, SS	1
7	610287	SLEEVE, P/M, 1.125D 0.750B 0.50L STL	2
8	1009333	●WHEEL, 8 X 2 W/HUB	2
9	069764631	WASHER, FLAT, M8.4X25.4X4.8	2
10	200370019	WASHER, LOCK, M8.4 ZN	15
11	16931	SCREW, HEX, M8X1.25X20, 8.8	2
12	630278	BRACKET, TIP ADJUST	1
13	08709	NUT, HEX, LOCK, M8X1.25, NL	1
14	41169	NUT, HEX, LOCK, .25-20, NL, SS	1
15	140000	WASHER, FLAT, 0.28B 0.62D .04, SS	1
16	610209	SPACER, .62HEX X .88LG 1/4-20TH	1
17	610285	SPRING, EXTENSION .500D X 2.25LG	2
18	610208	ARM, SQUEEGEE	1
19	578244000	WASHER, M6.4X10 LCK SS	1
20	610288	SCREW, HEX, .25-20X1.62 SS	1
21	578244000	WASHER, M6.4X10 LCK SS	1

● RECOMMENDED STOCK ITEMS

REF	PART #	DESCRIPTION	QTY.
22	363503	SCREW, PAN, M6X 1.0X12, SS	1
23	16931	SCREW, HEX, M8X1.25X20, 8.8	2
24	630047	PIN, CLEVIS 0.38DX0.75L	1
25	39005	PIN, COTTER, .094X0.75	1
26	630095	BEARING, .38IDX.50DX.25LG FLG	4
27	630003	FRAME, CASTER MOUNT	1
28	1010388	●CASTER, SWIVEL, 4.0D 1.38W 5.28H	1
29	32491	WASHER, FLAT, 0.31 STD	13
30	200303019	WASHER, M8.4X18X1.6 FLT ZN	1
31	200031486	SCREW, HEX, M8X1.25X16	8
32	630345	BOLT, SHLD, .38DX2.00, .31-18	1
33	630045	BRACKET, SQUEEGEE LIFT	1
34	630307	BRACKET, SAFETY AND LIMIT	1
35	41430	NUT, HEX, LOCK, M10X1.5, NL	1
36	16931	SCREW, HEX, M8X1.25X20, 8.8	5
37	578329000	SCREW, #6 ANCHOR NY	2
38	140032	WASHER, #6 FLT SS	2
39	590137	SCREW, TRS, #06-32X0.38, PHL, ZN	2
40	09291	SCREW, HEX, M10X1.5X20, SS	1
41	08709	NUT, HEX, LOCK, M8X1.25 NL	1

SCRUB HEAD LIFT GROUP

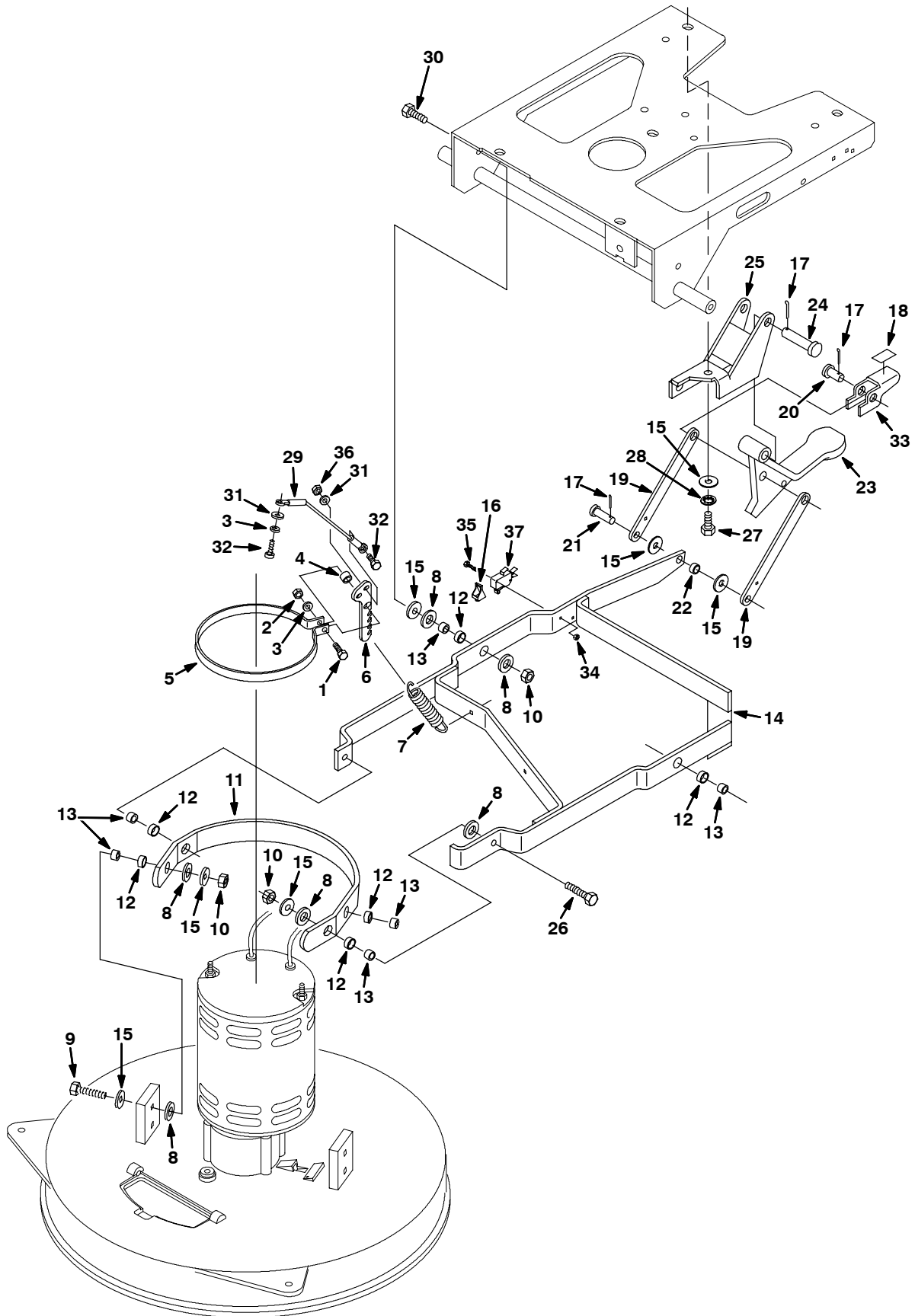

SCRUB HEAD LIFT GROUP

REF	PART #	DESCRIPTION	QTY.
1	200031444	SCREW, HEX, M6X1.0X30	1
2	579029	NUT, HEX, STD, M6X1.0 DIN 934P	1
3	578244000	WASHER, M6.4X10 LCK SS	2
4	140154	SLEEVE, P/M, 0.380D 0.255B 0.31L	1
5	630050	BAND, MOTOR SPRING MOUNT	1
6	630377	BRACKET, SCRUB HEAD LEVEL	1
7	630208	SPRING, EXTN, MOTOR COUNTER TORQUE	1
8	20536-2	WASHER, FLAT, 0.47B 1.19D .03, NYL	12
9	200031496	SCREW, M8X1.25X35	2
10	08709	NUT, HEX, LOCK, M8X1.25, NL	6
11	630177	BRACKET, MOTOR PIVOT	1
12	630188	BEARING, JOURNAL, .50IDX.25L	6
13	630189	SLEEVE, P/M, 0.496D 0.318B 0.21L STL PLT	6
14	630176	HEAD LIFT, WELDMENT	1
15	32491	WASHER, FLAT, 0.31 STD	11
16	600372	BOOT, SWITCH	1
17	578421	PIN, COTTER, .125DX1.00L	3
18	600721	PAD, ADH, NON-SLIP, .62X1.25, BLK	1
19	630182	ARM, LINK, HEADLIFT	2

REF	PART #	DESCRIPTION	QTY.
20	600720	PIN, CLEVIS, 0.50DX1.06L, ZN	1
21	630258	PIN, CLEVIS, 0.38DX1.00L	1
22	630259	BEARING, 9.5ID, 12.7OD, 6.4LG, BRZ	1
23	630181	PEDAL, FOOT HEADLIFT	1
24	630448	PIN, CLEVIS, 0.50DX2.25L	1
25	630206	BRACKET, HEADLIFT ASSY	1
26	200031494	SCREW, HEX, M8X1.25X30	2
27	16931	SCREW, HEX, M8X1.25X20, 8.8	1
28	200370019	WASHER, LOCK, M8.4 ZN	1
29	630384	CABLE, .093DX6.63, SS, VINYL-CTD	1
30	09010	SCREW, HEX, M8X1.25X25 SS	2
31	19066	WASHER, FLAT, #10	2
32	200031436	SCREW, HEX, M6X1.0X16	2
33	600719	LATCH, HEAD RELEASE	1
34	579211	NUT, HEX, LOCK, M3X.5, SS	2
35	579213	SCREW, HEX, M3X.5X20, ZN	2
36	08708	NUT, HEX, LOCK, M6X1.0, NL	1
37	611006	●KIT, SWITCH REPLACEMENT	1

● RECOMMENDED STOCK ITEMS

SCRUB BRUSH DRIVE GROUP

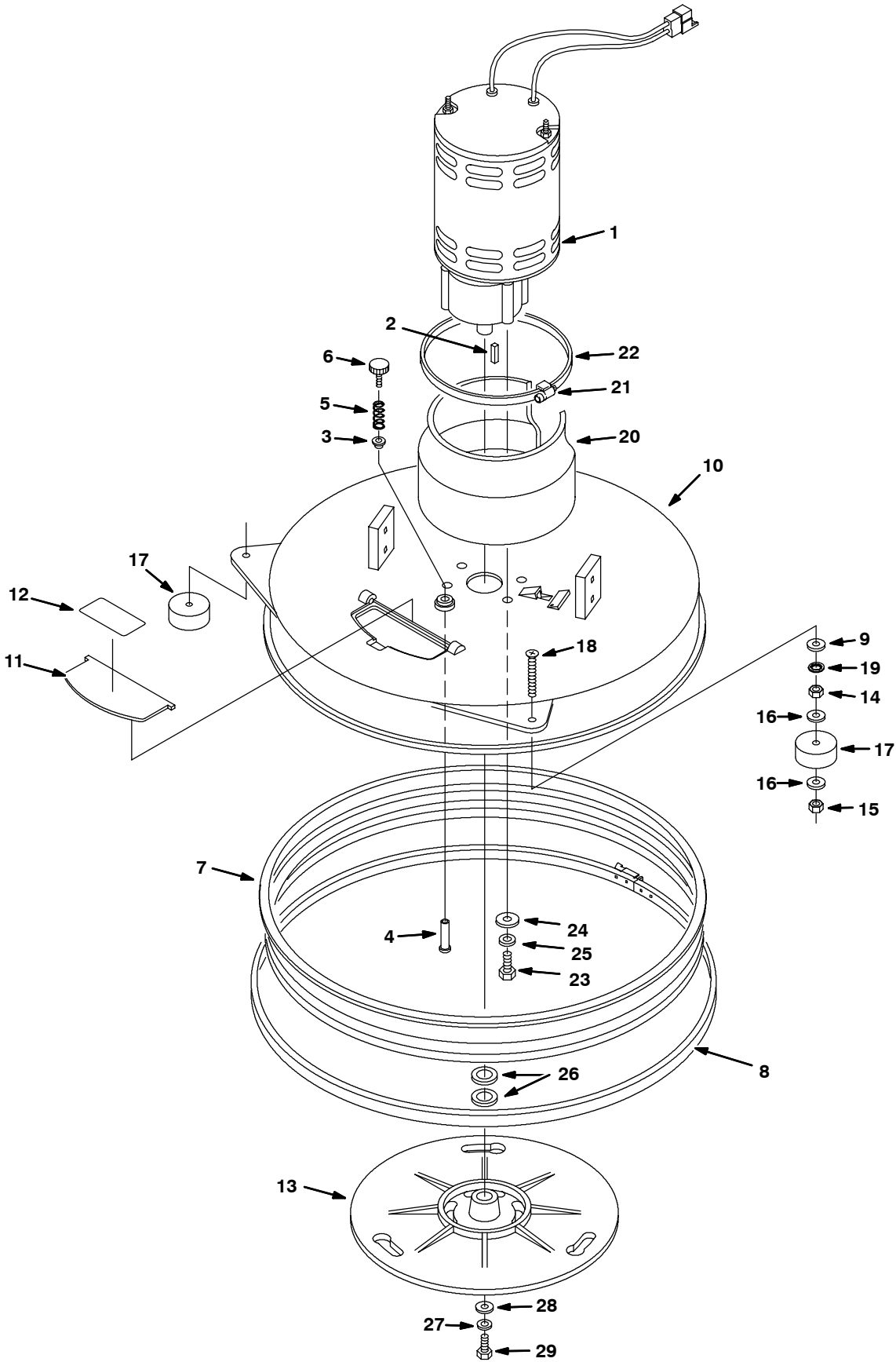

SCRUB BRUSH DRIVE GROUP

REF	PART #	DESCRIPTION	QTY.
▽ 1	610263	●MOTOR, ELE, 24VDC 0.75HP, 0200RPM, 33A	1
	190970	●BRUSH, CARBON, MOTOR, ELE	4
	611024	BRUSH BOARD ASM	1
	630609	GEARBOX ASSY	1
▲ 2	630454	KEY, 1/4X1/4X1-1/8	1
3	605825	SCREW, STOP, HEAD PIN	1
4	630308	PIN, CLEVIS, 8.3DX46.9L, M6X1	1
5	630310	SPRING, CMPR, HEAD STOP	1
6	603012	KNOB, RND, 19D, PLSTIC, M6X12 STUD, ZN	1
7	630506	●SKIRT, SCRBR HEAD, HEAVY DUTY	1
8	602045000	STRIP, SS	1.6M
	602044000	FASTENER, ADJUSTING	1
9	32491	WASHER, FLAT, 0.31 STD	2
10	630026	HEAD, SCRUBBER 20"	1
▽ 11	630603	KIT, BRUSH DOOR W/DCL	1
▲ 12	578769	LABEL, MOVING PARTS	1

REF	PART #	DESCRIPTION	QTY.
13	630039	HUB, DRIVE, BRUSH, STUD, 019MMB 0279MMBC	1
14	200101017	NUT, HEX, JAM, M8X1.25	2
15	08709	NUT, HEX, LOCK, M8X1.25, NL	2
16	630446	WASHER, FLAT, 0.31B 0.75D .06 NY	4
17	579184	WHEEL, 2.2D 0.88W .31B, RBR	2
18	630430	SCREW, FLT, M8X1.25X50, PHL, ZN	2
19	200370019	WASHER, LOCK, M8.4 ZN	2
20	611691	SHROUD, WATER MOTOR	1
21	602044000	FASTENER, ADJUSTING	1
22	606883	BAND, SS, 16.12"	1
23	059650308	SCREW, HEX, .38-16X1.00	4
24	140028	WASHER, FLAT, 0.42B 1.00D .05 SS	4
25	140017	WASHER, LOCK, SPLT, 0.38 SS	4
26	069760023	WASHER, FLAT, 0.77B 1.26D .03 SS	2
27	140015	WASHER, LOCK, SPLT, 0.31 SS	1
28	069764631	WASHER, FLAT, M8.4X25.4X4.8	1
29	140219	SCREW, HEX, .31-18X1.00 SS	1

▽ ASSEMBLY

▲ INCLUDED IN ASSEMBLY

● RECOMMENDED STOCK ITEMS

SCRUB BRUSH DOWN PRESSURE GROUP

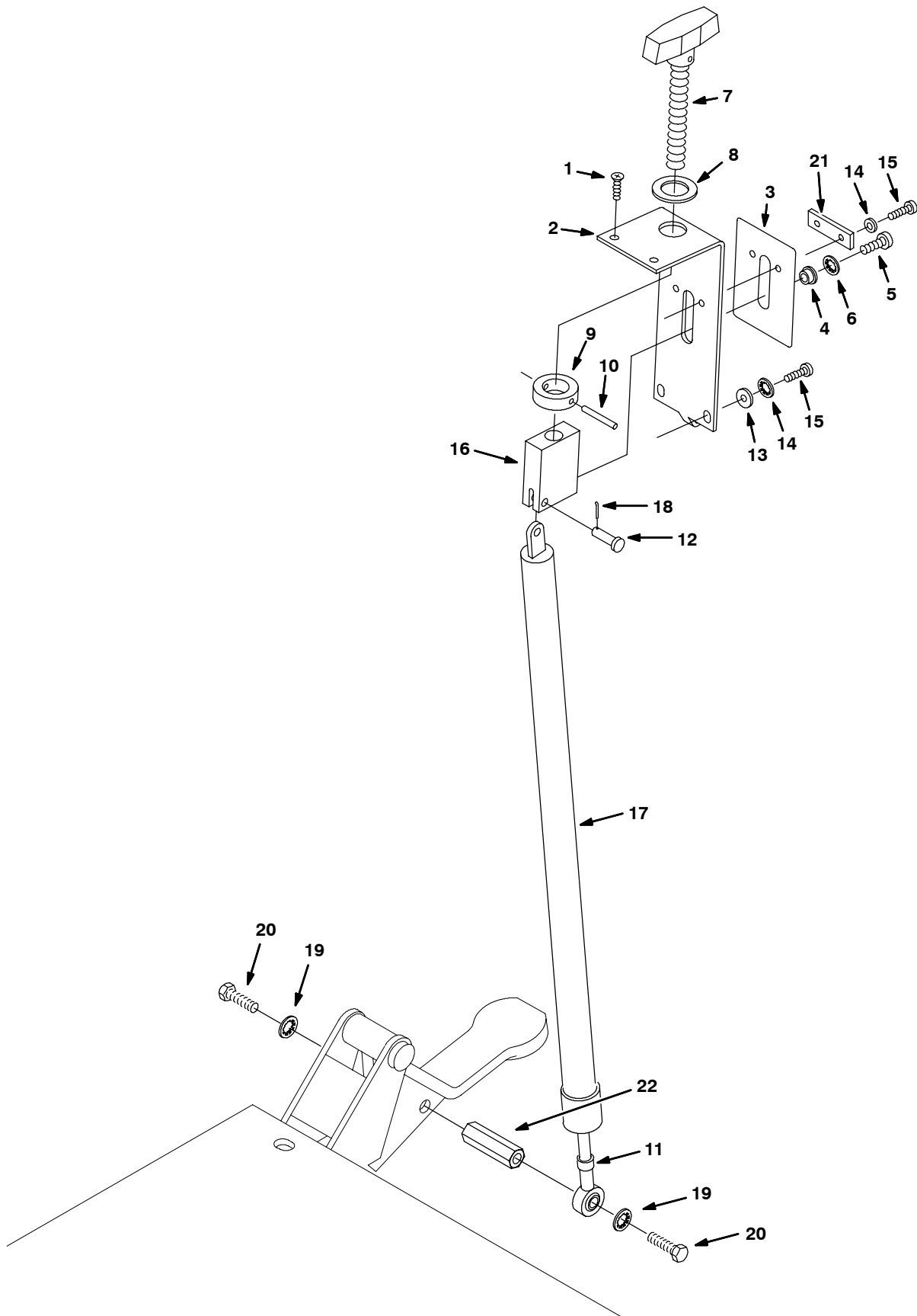

SCRUB BRUSH DOWN PRESSURE GROUP

REF	PART #	DESCRIPTION	QTY.
1	069764140	SCREW, FLT, M5X0.8X16, PHL, BO	2
2	630197	BRACKET, DOWN PRESSURE	1
3	630234	DECAL, DOWN PRESSURE	1
4	630482	BEARING, FLANGE OILITE #FF310-3	1
5	363503	SCREW, PAN, M6X1.0X12, SS	1
6	578244000	WASHER, M6.4X10 LCK SS	1
7	630195	KNOB ASSY, TEE, 2.5X0.7 .50-13 2.1L PLST	1
8	630358	WASHER, FLAT, 0.75B 1.00D .03 NY	1
9	630355	COLLAR, 1.06D 0.76B 0.3L .16H PLT	1
10	630382	PIN, SPRING, .16DX1.25L, ZN	1
11	612776	ROD-END, SHORT	1
12	630357	PIN, CLEVIS, 5.9DX20.2L	1

● RECOMMENDED STOCK ITEMS

REF	PART #	DESCRIPTION	QTY.
13	200315016	WASHER, FLAT, M5.3X15.0X1.6 ZN	2
14	07514	WASHER, LOCK, INT, #10, SS	4
15	575569000	SCREW, PAN, M5X0.8X16, PHL, DIN7985	4
16	630354	BLOCK, COUPLER, DOWN-PRESSURE, SHOCK	1
17	612060	●SHOCK, DOWN PRESSURE DBL SEAL (VERS. 3)	1
18	39005	PIN, COTTER, .094X0.75	1
19	200370019	WASHER, LOCK, M8.4 ZN	2
20	09010	SCREW, HEX, M8X1.25X25, SS	2
21	630356	BRACKET, STOP, DOWN PRESSURE	1
22	611378	SPACER, SHOCK	1

SQUEEGEE LIFT GROUP

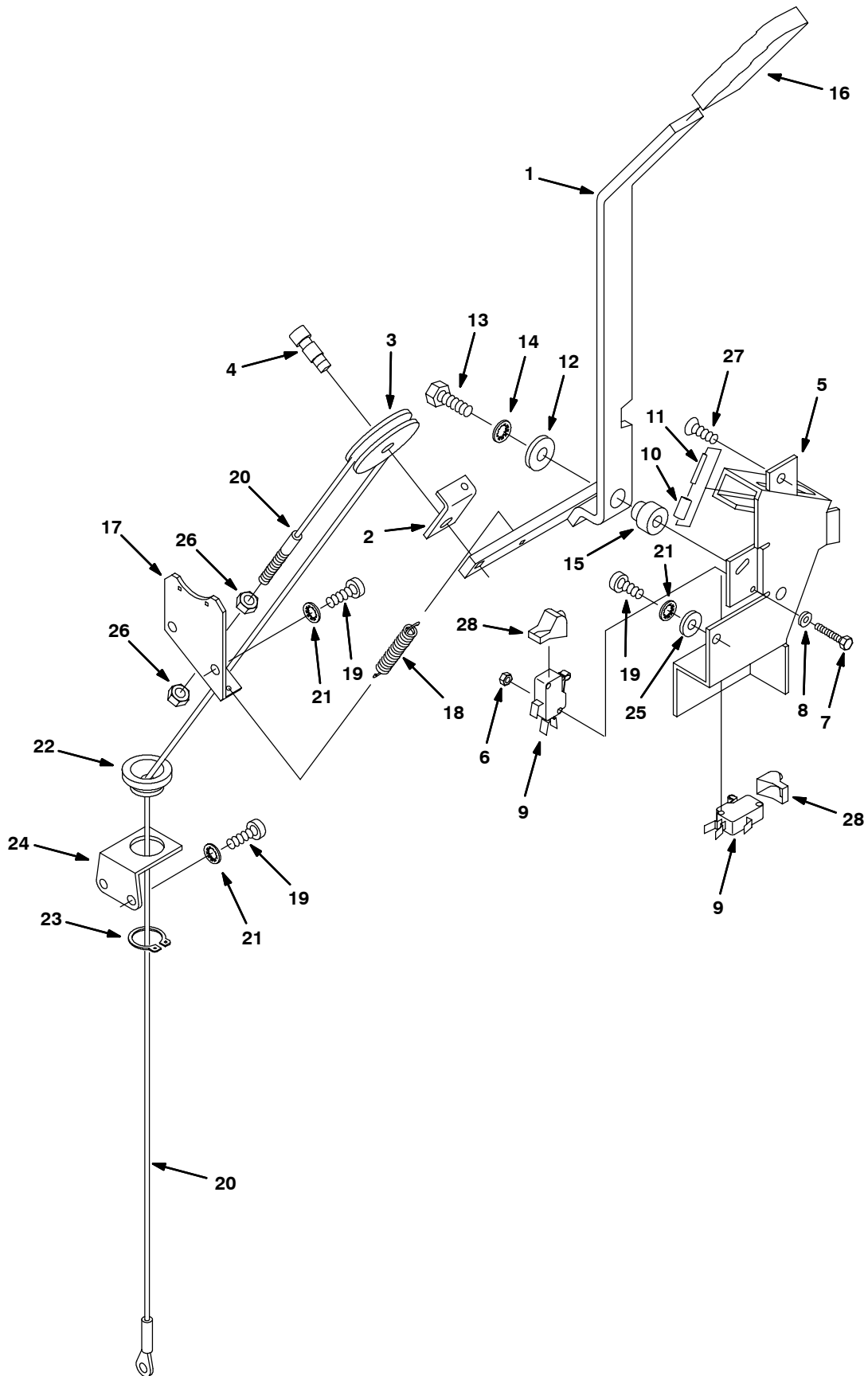

SQUEEGEE LIFT GROUP

REF	PART #	DESCRIPTION	QTY.
1	630151	ARM, LIFT, SQGE	1
2	630427	BRACKET, SQUEEGEE SHEAVE	1
3	630426	PULLEY, CABLE DIA. 2"X 3/16"	1
4	630470	BOLT, SHLD, .38DX.50, .31-18	1
5	630150	BRACKET, SQUEEGEE LIFT ARM	1
6	579211	NUT, HEX, LOCK, M3X.5, SS	4
7	579213	SCREW, HEX, M3X.5X20, ZN	4
8	601127000	WASHER, M3.7X8X.5 FLT ZN	4
9	611006	●KIT, SWITCH REPLACEMENT	2
10	630207	TUBE, 00.31D 00.10B 00.5L SS	1
11	630262	PIN, ROLL, .094DX0.87L, .094/.097 ZN	1
12	32490	WASHER, FLAT, 0.25 STD	1
13	200031496	SCREW, M8X1.25X35	1
14	200370019	WASHER, LOCK, M8.4 ZN	1

● RECOMMENDED STOCK ITEMS

REF	PART #	DESCRIPTION	QTY.
15	630160	SLEEVE, P/M, FLNG 0.75D 0.31B 0.7L	1
16	630209	GRIP, SQUEEGEE LIFT	1
17	630155	BRACKET, SQUEEGEE CABLE 11GA ZP	1
18	630158	SPRING, EXTN, .38X3.00X.045 MW ZN	1
19	608322	SCREW, TRS, M6X1.0X16, PHL, SS	5
20	1015636	CABLE, SQUEEGEE LIFT	1
21	578244000	WASHER, M6.4X10 LCK SS	5
22	1009363	BUSHING, CABLE	1
23	621236000	RING, RETAINING .810 DIA	1
24	630157	BRACKET, CABLE GUIDE, 11GA, ZP	1
25	140000	WASHER, FLAT, 0.28B 0.62D .04, SS	1
26	32520	NUT, HEX, JAM, .25-20	2
27	069762098	SCREW, FLT, M6X1.0X16, PHL, SS	1
28	600372	BOOT, SWITCH	2

SQUEEGEE GROUP

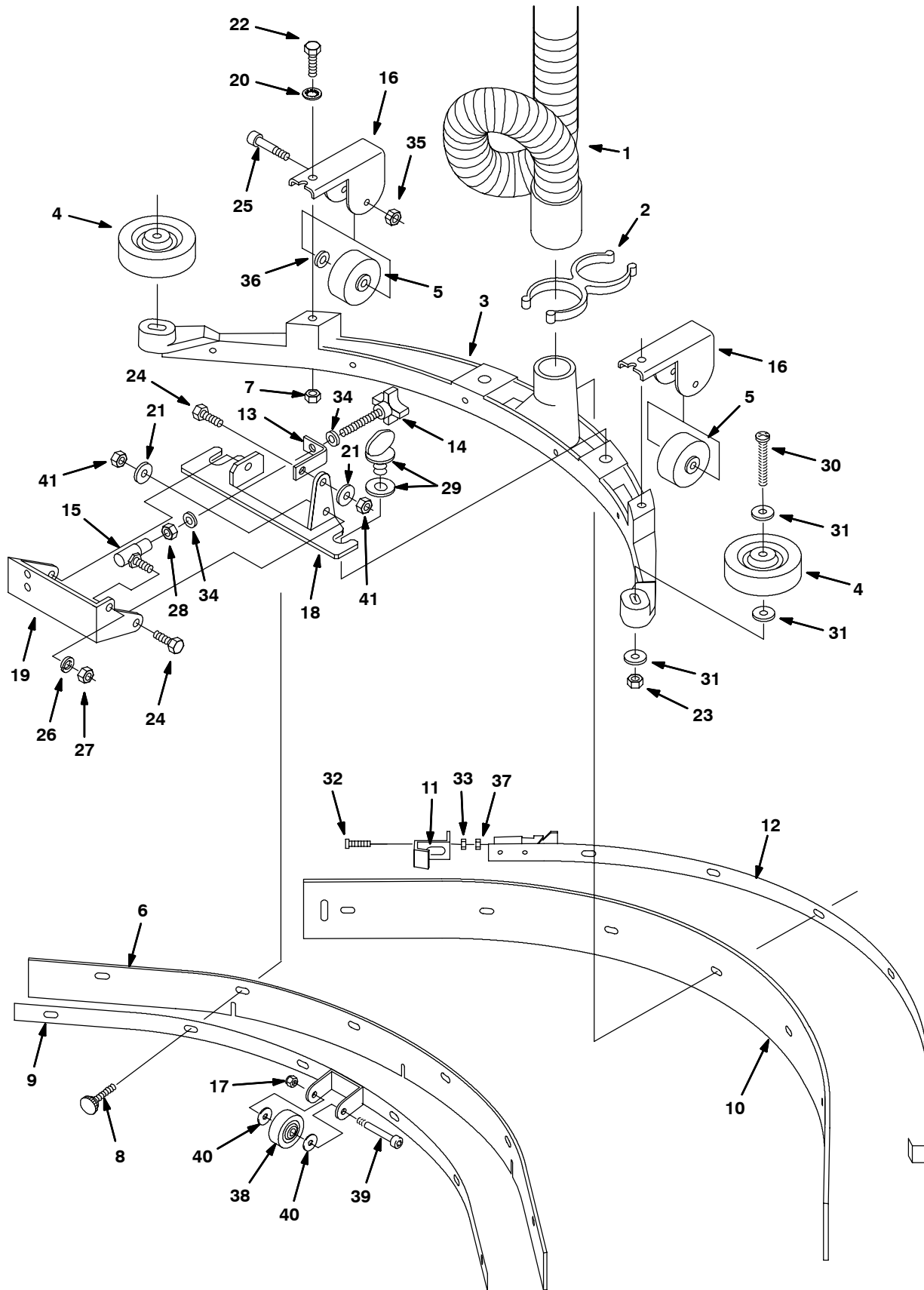

SQUEEGEE GROUP

REF	PART #	DESCRIPTION	QTY.	
▽	610989	ASM, SQUEEGEE	1	
1	630339	●HOSE ASSY, SQGE	1	
2	1014079	CLIP, HOSE, GRIPPER	1	
▲	3	630311	SQUEEGEE, CURVED	1
▲	4	1014918	WHEEL, RBR, 3"X1" W/BUSHING	2
▲	5	579184	●WHEEL, 2.2D 0.88W .31B, RBR	2
▲	6	610148	●BLADE, SQGE, FRONT 30"L LINATEX	1
		610147	●BLADE, SQGE, FRONT 30"L GUM RBR	1
		610149	●BLADE, SQGE, FRONT 30"L URETHANE	1
	QUARRY TILE BLADES			
	630288	●BLADE, SQGE, FRONT 762MML SEMI CRVD LINATEX	1	
	630291	●BLADE, SQGE, FRONT 762MML SEMI GUM RBR	1	
	600207	●BLADE, SQGE, FRONT 762MML URETHANE	1	
▲	7	07786	NUT, HEX, STD, M8X1.25, SS	2
▲	8	603012	KNOB, RND, 19D, PLSTIC, M6X12 STUD, ZN	6
▲	9	610257	STRAP ASSY, SQGE, 500MM	1
▲	10	610150	●BLADE, SQGE, REAR, 31.81"L LINATEX	1
		630344	●BLADE, SQGE, REAR, 808MML GUM RBR	1
		610691	●BLADE, SQGE, REAR 31.81"L URETHANE	1
▲	11	610850	CLIP, BAND FULL CURVE	1
▲	12	630350	STRAP ASSY, SQGE, 500MM	1
	13	630279	BRACKET, TIP ADJUST PIVOT	1
	14	630281	KNOB ASSY, STAR, 1.50D 4EAR .31-24 2.0L	1

REF	PART #	DESCRIPTION	QTY.	
	15	140119	BALLJOINT, .31-24 FEM, .31-24 MAL	1
▲	16	630314	BRACKET, SQ, BACKUP, WHEEL	2
▲	17	601108000	NUT, 5/16-18 HXLCK THIN NY	1
	18	630277	BRACKET, SQUEEGEE ATTACH	1
	19	630278	BRACKET, TIP ADJUST	1
▲	20	200370019	WASHER, LOCK, M8.4 ZN	2
	21	200303019	WASHER, M8.4X18X1.6 FLT ZN	3
▲	22	200031494	SCREW, HEX, M8X1.25X30	2
▲	23	08709	NUT, HEX, LOCK, M8X1.25, NL	2
	24	16931	SCREW, HEX, M8X1.25X20, 8.8	3
▲	25	630480	BOLT, SHLD, .31DX1.25, .25-20	2
	26	140015	WASHER, LOCK, SPLT, 0.31 SS	1
	27	140508	NUT, 5/16-24 HEX ZN	1
	28	630388	NUT, 5/16-24 HXLCK NY ZN	1
▲	29	630393	●SCREW, THUMB W/WASHER ASSY	2
▲	30	630424	SCREW, PAN, M8X1.25X70, PHL ZN	2
▲	31	630303	WASHER, FLAT, M8.4X25.4X2.0 ZN	6
▲	32	630389	SCREW, PAN, M5X0.8X45, PHL SS	1
▲	33	09739	NUT, HEX, LOCK, M5X0.8, NL, SS	1
	34	630446	WASHER, FLAT, 0.31B 0.75D .06 NY	2
▲	35	41169	NUT, HEX, LOCK, .25-20, NL, SS	2
▲	36	200651019	WASHER, FLAT, M8.4X17X1.6 SS	2
▲	37	140297	NUT, HEX, STD, M5X0.8, SS	1
▲	38	630477	●WHEEL, 2.0D 0.38W POLY GRAY	1
▲	39	600187	BOLT, SHLD, .38DX1.25, .31-18	1
▲	40	140028	WASHER, FLAT, 0.42B 1.00D .05 SS	2
	41	08709	NUT, HEX, LOCK, M8X1.25, NL	3

▽ ASSEMBLY

▲ INCLUDED IN ASSEMBLY

● RECOMMENDED STOCK ITEMS

BATTERY AND CHARGER GROUP

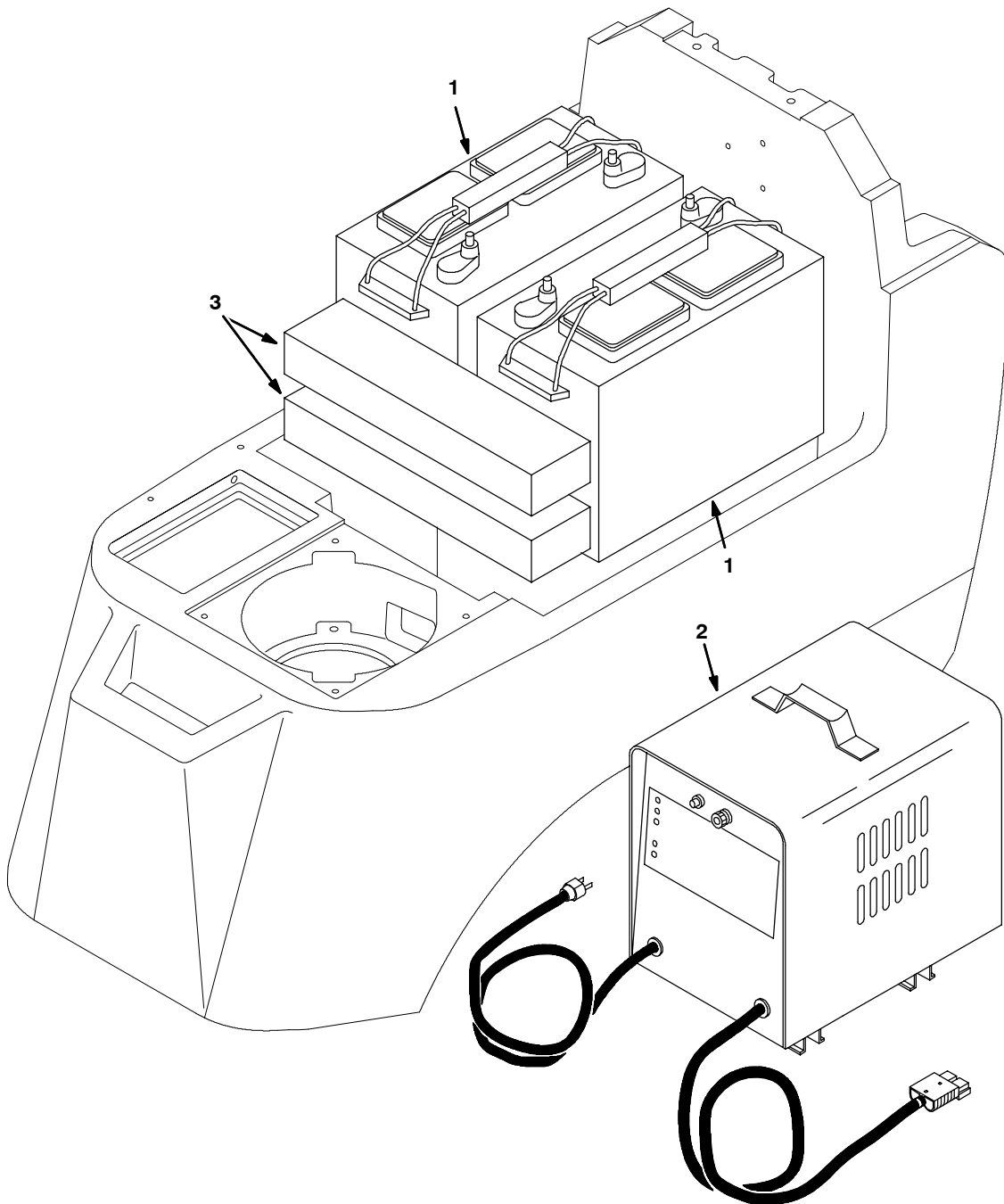

REF	PART #	DESCRIPTION	QTY.
1	130869	●BATTERY, 12VDC, CCA, 130AH (30XHS-WNT)	2
	600394	BATTERY, 12VDC, CCA, 215AH DUAL POST	2

● RECOMMENDED STOCK ITEMS

REF	PART #	DESCRIPTION	QTY.
2	603553	●CHARGER 24DC/12A 120V DUAL-MODE (FOR 130AH BATTERIES)	1
	603235	CHARGER, 24DC/20A/120AC (FOR 215AH BATTERIES)	1
3	630375	SPACER, BATTERY FOAM	4

BATTERY CABLE GROUP

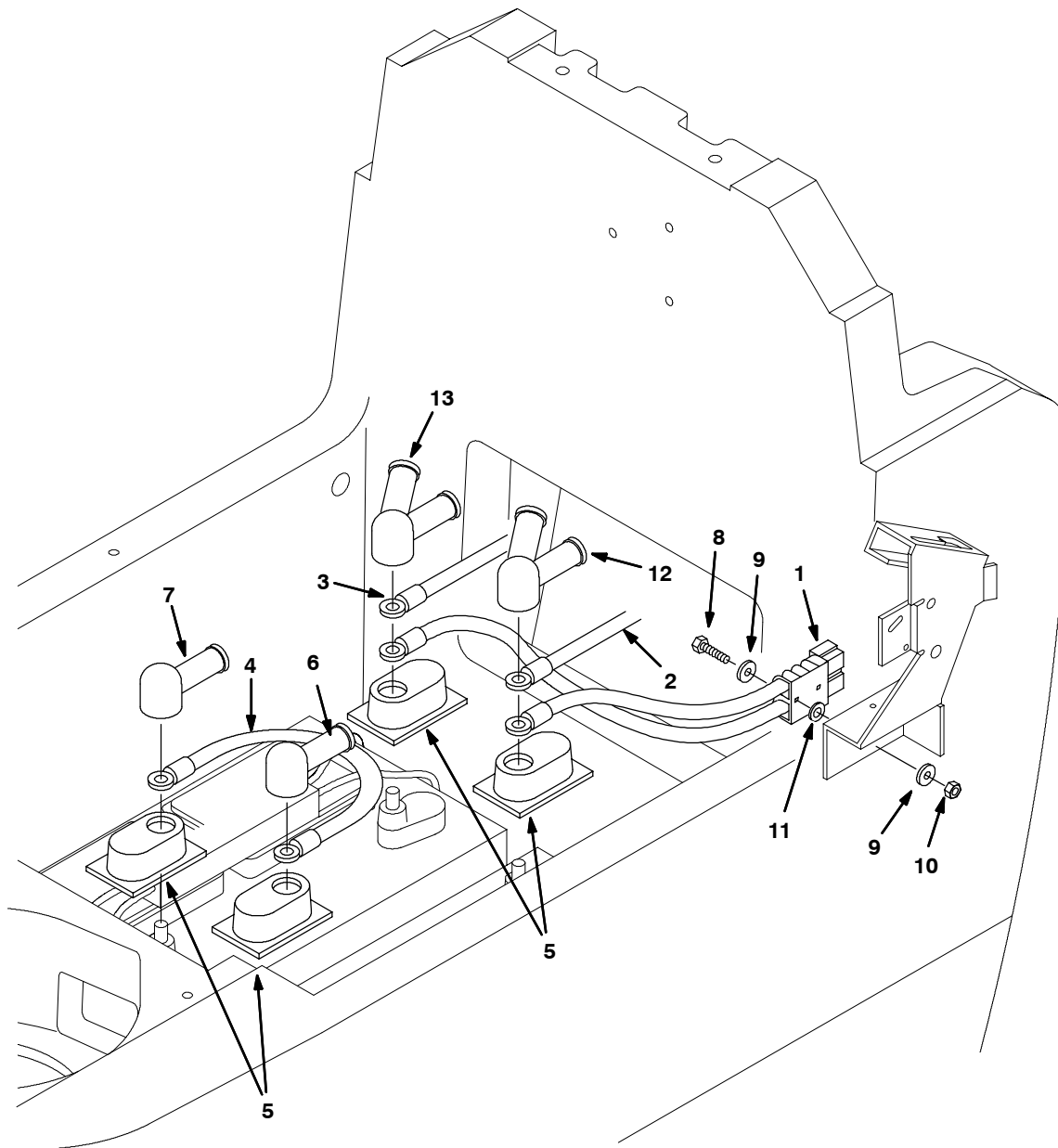

REF	PART #	DESCRIPTION	QTY.
1	630118	CABLE, BATTERY, W/RED CHARGE PLUG	1
2	630110	CABLE, BATTERY, 4GA, 813MM, RED	1
3	630111	CABLE, BATTERY, 4GA, 864MM, BLACK	1
4	603061	CABLE, BATTERY, 6GA, 305MM, RED	1
5	45962	CAP, PLSTC, .04 1.38X2.30 .05L	4

REF	PART #	DESCRIPTION	QTY.
6	611221	BOOT, CABLE, BATTERY, BLACK	1
7	611222	BOOT, CABLE, BATTERY, RED	1
8	200051274	SCREW, FIL, M3X.5X30, SLOT	2
9	601127000	WASHER, M3.7X8X.5 FLT ZN	4
10	579211	NUT, HEX, LOCK, M3X.5, SS	2
11	140019	WASHER, LOCK, EXT, #06 ZN	2
12	606011	BOOT, INSULATING CABLE, RED	1
13	606010	BOOT, INSULATING CABLE, BLK	1

WET PICK-UP TOOL KIT

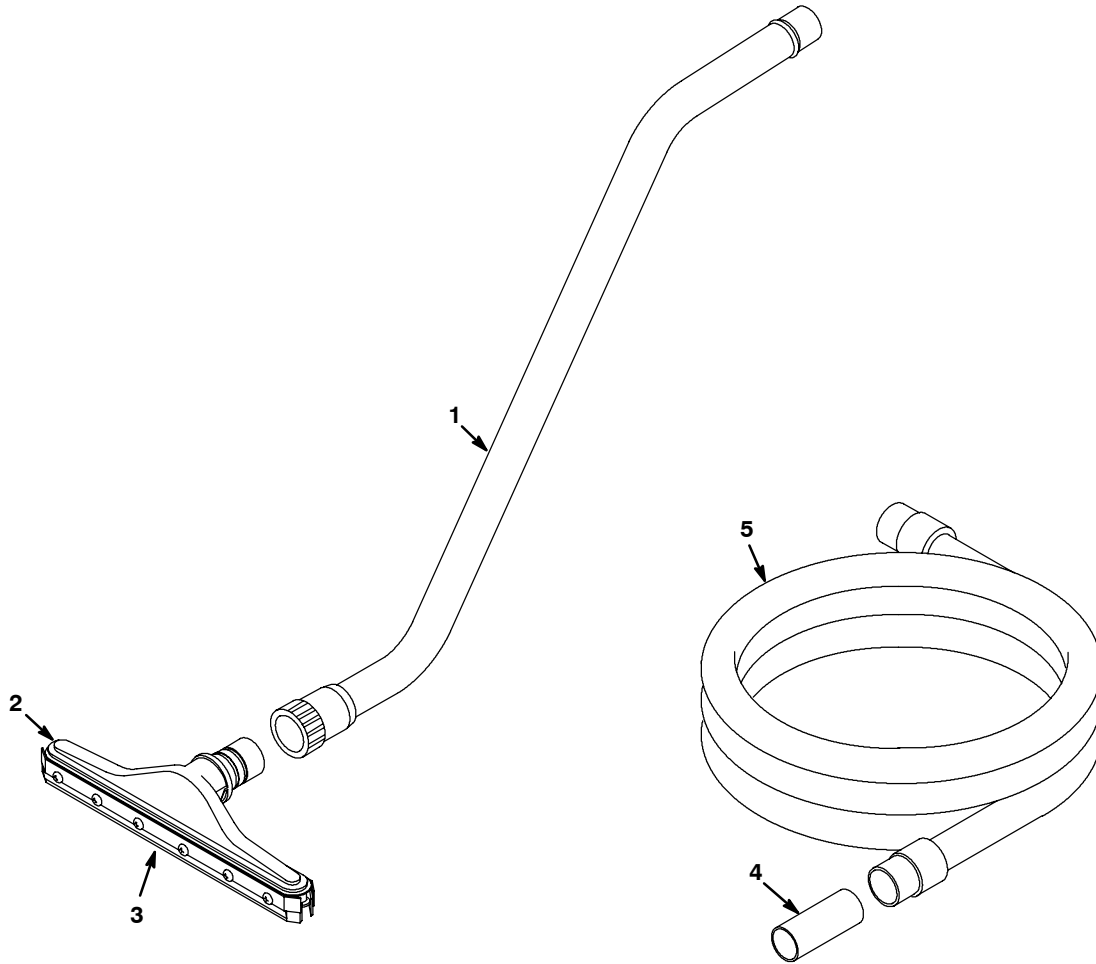

REF	PART #	DESCRIPTION	QTY.
▽	190928	●KIT, AUTOSCRUB WET PICK-UP	1
▲▽ 1	6108.1	●WAND, TWO BEND ALUMINUM	1
▲	605257	●RING, LOCK	1
▲	600828	●NUT, WAND COUPLING	1
▲▽ 2	13840	●SQUEEGEE ASSEM, PUSH/PULL 14"	1
▲	605137	●BLADES, REPLACEMENT (SET OF 4)	1

REF	PART #	DESCRIPTION	QTY.
▲ 4	160451	●CONNECTOR, 1-1/2 VACUUM HOSE	1
▲ 5	160481	●HOSE, VACUUM 1.5DX10'L, 1-SWIVEL CUFF	1

▽ ASSEMBLY

▲ INCLUDED IN ASSEMBLY

● RECOMMENDED STOCK ITEMS

NON-POWER WAND GROUP

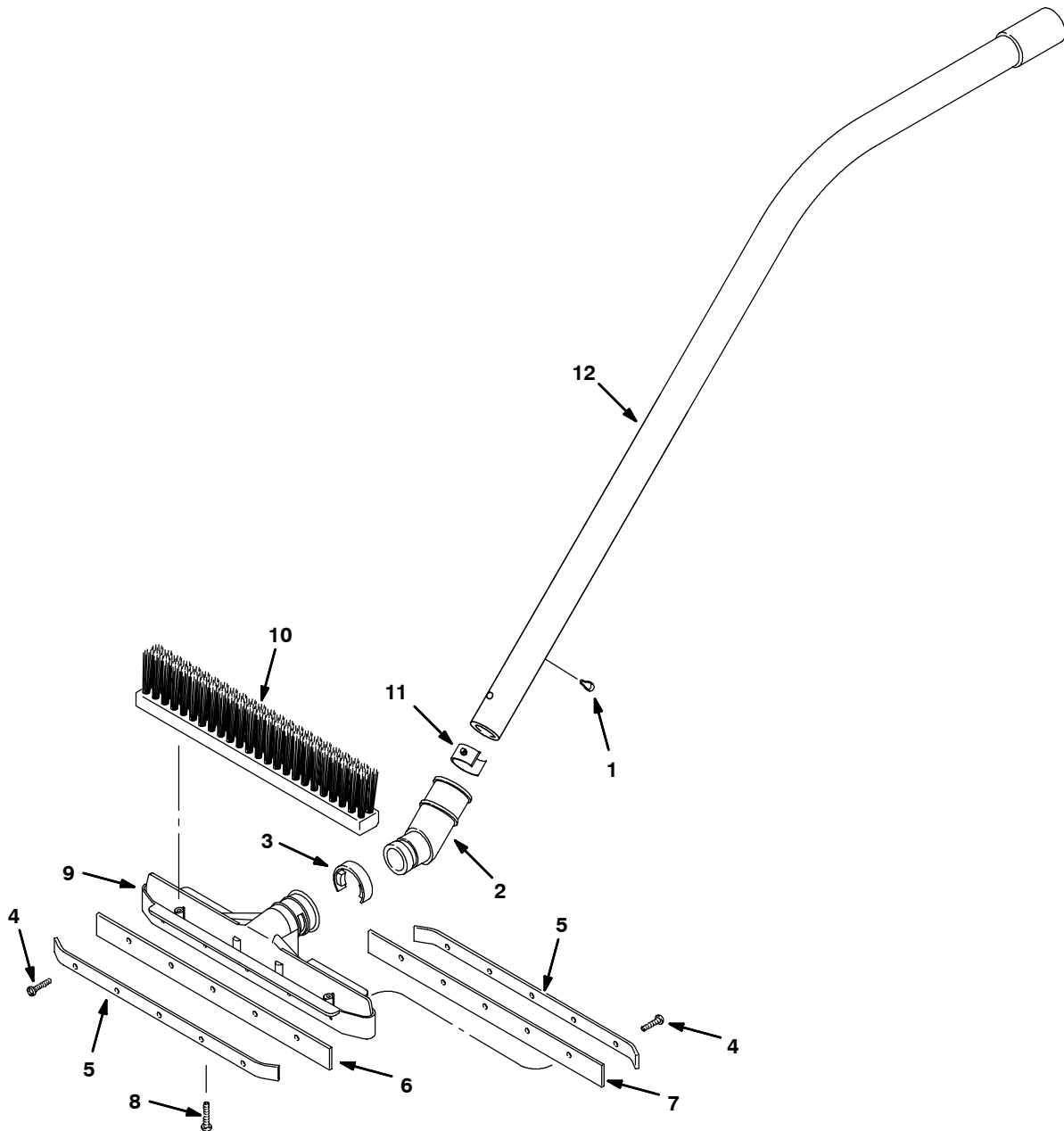

REF	PART #	DESCRIPTION	QTY.
∇	630732	●KIT, WAND, NON-POWER	1
▲ 1	630269	●BUMPER, MUSH/STEAM STYLE, 4.8DIA	2
▲ 2	579113	●SWIVEL, WAND ATTACHMENT	1
▲ 3	579132	●RING ATTACHMENT	1
▲ 4	579135	●SCREW, SELF TD UNITED EL P1545S	10
▲ 5	579103	●RETAINER WAND BLADE	2

REF	PART #	DESCRIPTION	QTY.
▲ 6	579239	●BLADE, SQGE, FRONT 333MML URETHANE (150)	1
▲ 7	579230	●BLADE, SQGE, REAR 333MML URETHANE (150)	1
▲ 8	579147	●SCREW, PAN, #06-32X1.5, T-CUT, B	2
▲ 9	579101	●HEAD WAND E150	1
▲ 10	579102	●BRUSH WAND 2-ROW	1
▲ 11	579187	●CLIP SPRING 32MM	1
▲ 12	579109	●WAND, SINGLE BEND 31.8	1

∇ ASSEMBLY

▲ INCLUDED IN ASSEMBLY

● RECOMMENDED STOCK ITEMS

POWER WAND GROUP

REF	PART #	DESCRIPTION	QTY.
▽	579908	●WAND ASSY, E150, SNGL BN NO HOSE	1
▲ 1	578091000	●FITTING, BRS, QDC, PM04 PLUG	1
▲ 2	578160000	CLAMP, HOSE, EAR, 11-13MM, SS	4
▲ 3	613536	●HOSE, 1/4IDX7/16OD REINF578227000 M 0.400	1
▲ 4	579107	●VALVE, WATER, FLOW CNTRL 04BM	1
▲ 5	150525	FITTING, BRS, STR, PM02/BM04	2
▲ 6	613537	●HOSE, 1/4IDX7/16OD REINF578227000 M 1.083	1
▲ 7	579112	FITTING SPRAY NOZZLE ADAPTER	1
▲ 8	579198	RIVET, BLIND, .156DX0.31X.38D, SS	2
▲ 9	579137	●FITTING, BRS, TIP, 9508, 1/8V-JET	1
▲ 10	579113	SWIVEL WAND ATTACHMENT	1
▲ 11	579132	RING ATTACHMENT	1

REF	PART #	DESCRIPTION	QTY.
▲ 12	579135	SCREW, SELF TD UNITED EL P1545S	10
▲ 13	579103	RETAINER WAND BLADE	2
▲ 14	579239	●BLADE, SQGE, FRONT 333MML URETHANE (150)	1
▲ 15	579230	●BLADE, SQGE, REAR 333MML URETHANE (150)	1
▲ 16	579147	SCREW, PAN, #06-32X1.5, T-CUT, B	2
▲ 17	579101	HEAD WAND E150	1
▲ 18	579102	●BRUSH WAND 2-ROW	1
▲ 19	579187	CLIP SPRING 32MM	1
▲ 20	150208	FITTING, BRS, STR, PM02 PLUG	1
▲ 21	579109	WAND, SINGLE BEND	1
▲ 22	150510	FITTING, BRS, STR, PF04/BM04	1

▽ ASSEMBLY

▲ INCLUDED IN ASSEMBLY

● RECOMMENDED STOCK ITEMS

DELUXE POWER WAND GROUP

REF	PART #	DESCRIPTION	QTY.
▽	578905000	●WAND ASSY 170ER/BR, DBLBN, 38.1	1
▲ 1	578060000	WAND, DOUBLE BEND, DIA 38.1MM	1
▲ 2	578077000	BRACKET VALVE MOUNTING WAND	1
▲ 3	578061000	ADAPTER HEAD/WAND 17B/E	2
▲ 4	578214000	FITTING, PLSTC, E90, PM02/BM04	1
▲ 5	579112	FITTING, SPRAY NOZZLE ADAPTER	1
▲ 6	579198	RIVET, BLIND, .156DX0.31X.38D, SS	2
▲ 7	578066000	●FITTING, BRS, TIP, 75, 1/8K-JET	1
▲ 8	578073000	●BRUSH DECK POLYPRO BLOCK	1
▲ 9	578063000	HEAD, WAND, 17B/E	1
▲ 10	578078000	RETAINER, SQUEEGEE WAND	2
▲ 11	578074000	●BLADE, SQUEEGEE WAND, 17B/E	2
▲ 12	578124000	BRACKET, AXLE, 1 HOLE, 17B/E	1
▲ 13	578439	NUT, THUMB, M6X1.0, 30DIA	1
▲ 14	613732	SPRING, CMPR, CONICAL 15MM	1
▲ 15	578143000	SCREW, SET, M6X1.0X40, CUPPT, SS	1
▲ 16	578126000	AXLE, WAND, 17B/E	1
▲ 17	578125000	●WHEEL, 41.3D, 19.1W, RBR	2
▲ 18	578123000	BRACKET, AXLE, 3HOLE, 17B/E	1

▽ ASSEMBLY

▲ INCLUDED IN ASSEMBLY

● RECOMMENDED STOCK ITEMS

REF	PART #	DESCRIPTION	QTY.
▲ 19	578155000	WELDMENT HANDLE WAND	1
▲ 20	578154000	BRACKET HANDLE WAND	1
▲ 21	578091000	●FITTING, BRS, QDC, PM04, PLUG	1
▲ 22	578164000	GROMMET, 0.38"ID, 0.62"GD, .06"GW	1
▲ 23	578821000	●HOSE, 1/4IDX3/8ODX1.22M	1
▲ 24	578161000	CLAMP, HOSE, EAR, 8-11MM, SS	1
▲ 25	578094000	FITTING, BRS, STR, PM04/BM04	1
▲ 26	578064000	●VALVE, WATER CONTROL	1
▲ 27	150208	FITTING, BRS, STR, PM02, PLUG SKHD	1
▲ 28	20399	BOLT, CARRIAGE, .25-20X0.75	2
▲ 29	200304017	WASHER, FLAT, M6.4X13X1.6 ZN	2
▲ 30	41169	NUT, HEX, LOCK, .25-20, NL, SS	2
▲ 31	07785	NUT, HEX, STD, M6X1.0, A2, SS	1
▲ 32	578144000	SCREW, PAN, M5X0.8X16, PHL, SS, DN7985A	4
▲ 33	578141000	SCREW, PAN, M5X0.8X10, PHL, SS, DN7985A	4
▲ 34	07514	WASHER, LOCK, INT, #10, SS	8
▲ 35	140885	SCREW, TRS, .25-20X0.50, PHL, SS	2
▲ 36	578566	SCREW, 4X30 FLTPHL SS	2
▲ 37	33932	NUT, HEX, LOCK, M4X0.7, NL, SS	2
38	65582	●BRUSH, POWER WAND, W/FASTENER, ABR (OPTIONAL)	1

NON-POWER WAND HOSE GROUP

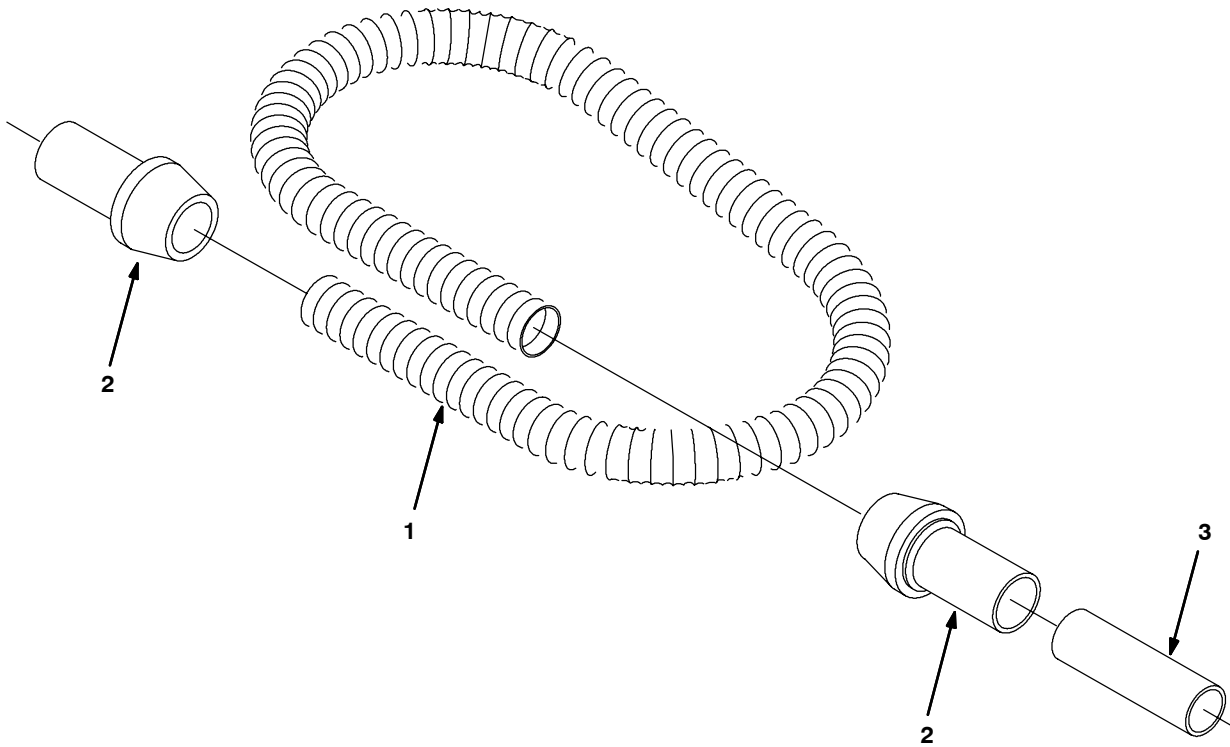

REF	PART #	DESCRIPTION	QTY.
▽	630739	●HOSE ASSY, VAC, DIA 38.1X3.05M	1
▲ 1	578276000	HOSE, VACUUM, 1.5DX10'L, GRAY	1

REF	PART #	DESCRIPTION	QTY.
▲ 2	630449	●CUFF, HOSE, 1.50 SOFT	2
▲ 3	231031	●TUBE, 01.50D 05.0L	1

▽ ASSEMBLY

▲ INCLUDED IN ASSEMBLY

● RECOMMENDED STOCK ITEMS

POWER WAND HOSE GROUP

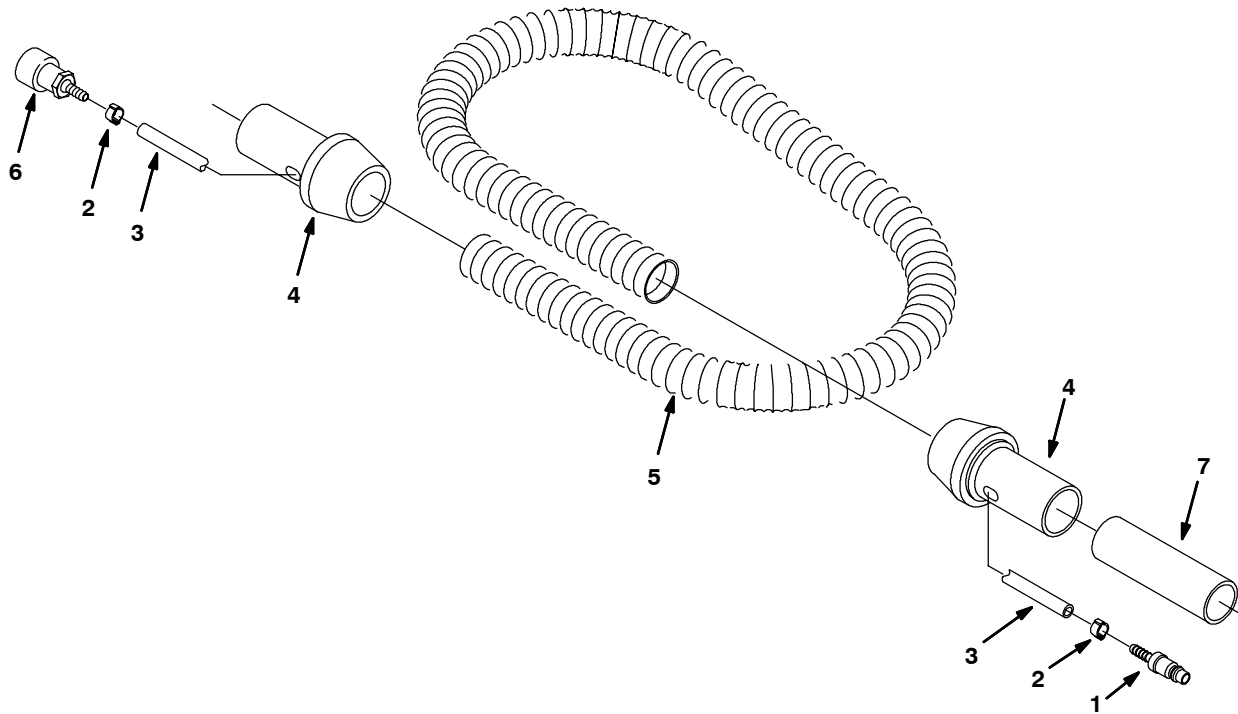

REF	PART #	DESCRIPTION	QTY.
∇	578903000	●HOSE ASSY, 170ER/BR, DIA 38.1	1
▲ 1	578318000	●FITTING, STL, QDC, PM06/BM04	1
▲ 2	140325	CLAMP, HOSE, EAR, 0.50D, SS	2
▲ 3	578820000	HOSE, .25"ID, .44"OD, 4.0M LG	1

REF	PART #	DESCRIPTION	QTY.
▲ 4	578072000	●CUFF SWIVEL, 1-1/2 BLACK	2
▲ 5	578276000	HOSE, VACUUM, 1.5DX10'L, GRAY	1
▲ 6	578071000	●QUICK CONN, FEMALE 1/4"X1/4"H	1
▲ 7	231031	●TUBE, 01.50D 05.0L	1

∇ ASSEMBLY

▲ INCLUDED IN ASSEMBLY

● RECOMMENDED STOCK ITEMS

ACCESSORY CONSOLE GROUP

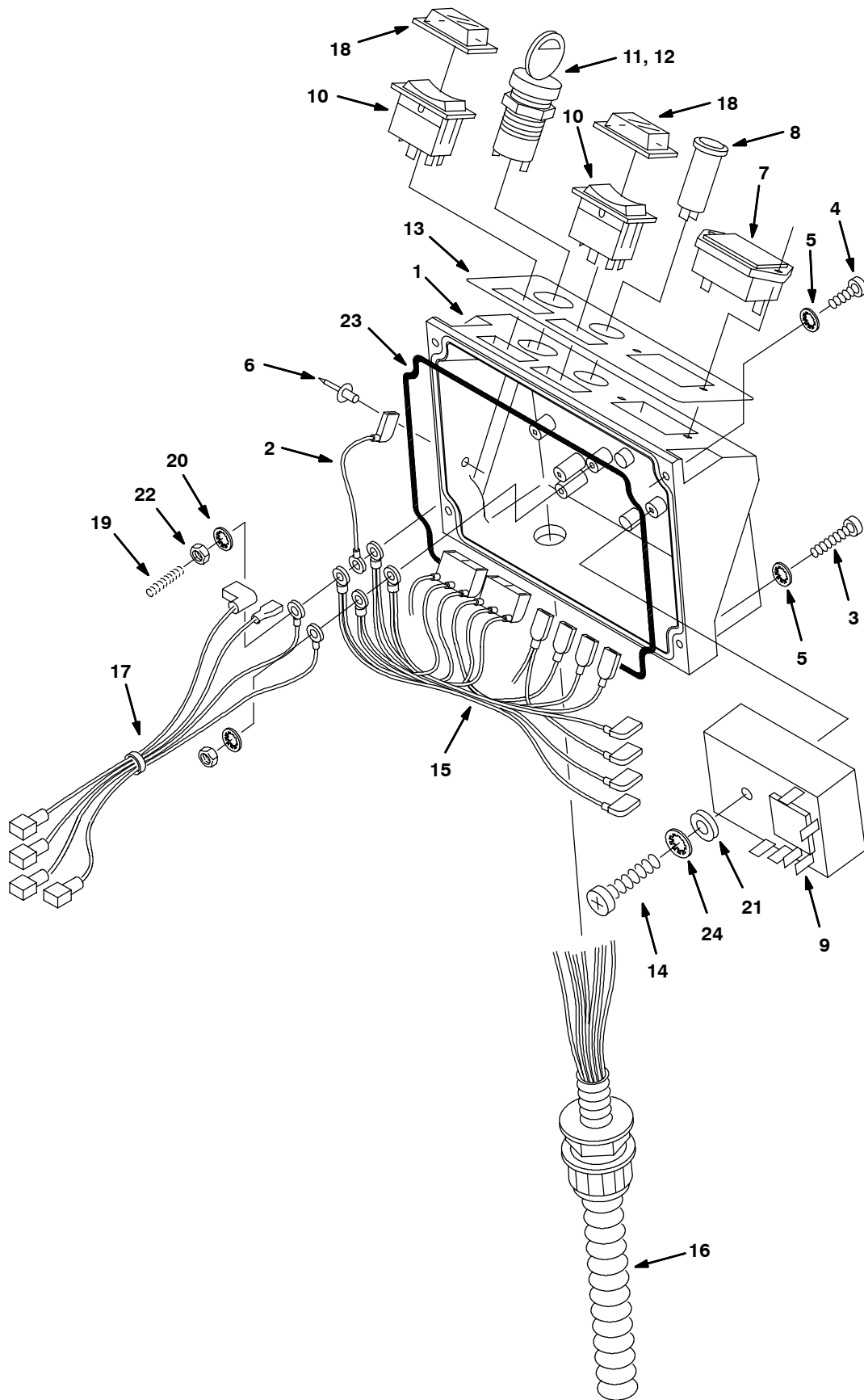

ACCESSORY CONSOLE GROUP

REF	PART #	DESCRIPTION	QTY.
	607486	KIT, KEY/HR MTR	1
	607487	KIT, ES/KEY/HR MTR	1
	607488	KIT, ES/WAND PUMP/KEY/HR MTR	1
	607489	KIT, WAND PUMP	1
	607490	KIT, KEY/HR MTR/WAND PUMP	1
1	630140	CONSOLE, OPTIONS, 20" SCRUBBER	1
2	630331	WIRE ASSY, KEY SWITCH	1
3	200070354	SCREW, PAN, M4X0.7X30, PHL, ZN	2
4	140287	SCREW, PAN, M4X0.7X16, PHL, ZN	2
5	02938	WASHER, LOCK, INT, 08, SS	4
6	578852	RIVET, PLSTC, .200DX0.20, SNAP	1
7	1010555	GAUGE, HOURMETER, 14-48VDC, LCD, RT	1
8	630142	LIGHT, PILOT, 24VDC, BLUE	1
9	630145	TIMER	1
10	630419	SWITCH, ROCKER, 28VDC, A SPST	2
11	607475	SWITCH, KEYLOCK, 12AMP	1
12	607821	KEY, REPLACEMENT, STEEL	1

REF	PART #	DESCRIPTION	QTY.
13	630235	DECAL, OPTION KEY/HOURMETER	1
	630236	DECAL, OPTION ES/KEY/HR/LGT	1
	630237	DECAL, OPTION ES/KEY/HR/LGT/WP	1
	630238	DECAL, OPTION WAND PUMP	1
	630239	DECAL, OPTION KEY/HR/W.PUMP	1
14	630334	SCREW, PAN, #06-32X1.38 PHL, TCUT, B	1
15	606499	HARNESS, WIRE OPTION	1
16	630342	HARNESS, ES	1
17	606502	HARNESS, ACCESSORY	1
18	578720	SPLASH GUARD, ROCKER SWITCH	2
19	601271	SCREW, STUD, M4X0.7X25, ZN	2
20	02938	WASHER, LOCK, INT, 08, SS	2
21	140026	WASHER, #6 FLT SAE ZN	1
22	200102014	NUT, HEX, STD, M4X0.7, DIN 934P	2
23	630442	SEAL, O-RING, 540MM	1
24	07514	WASHER, LOCK, INT, #10, SS	1

WAND PUMP PLUMBING GROUP

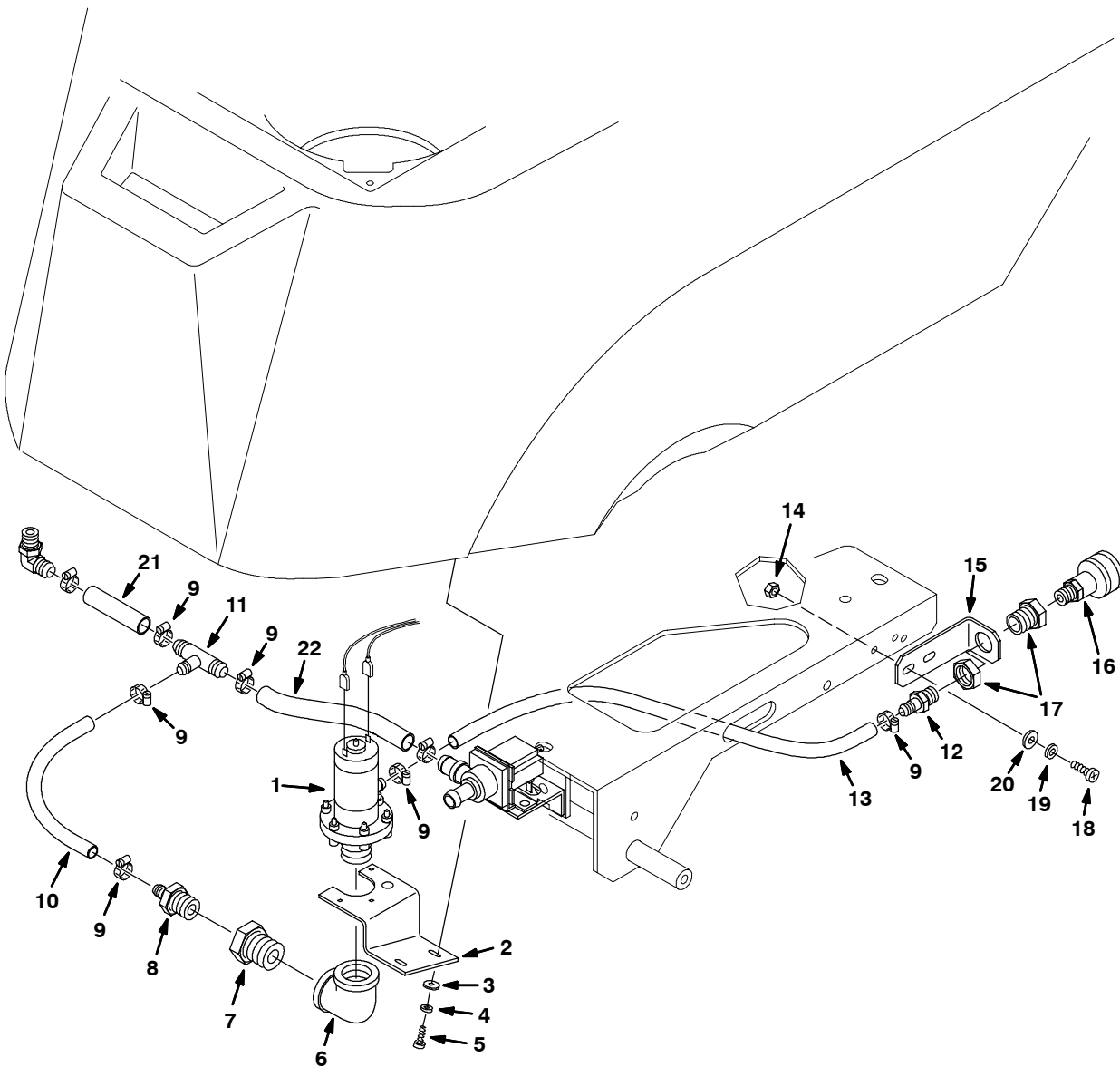

REF	PART #	DESCRIPTION	QTY.
1	630136	●PUMP, SOL, 24VDC 3/16" TERM 3/4"	1
2	630335	BRACKET, MTG, PUMP	1
3	200315016	WASHER, FLAT, M5.3X15.0X1.6 ZN	2
4	07514	WASHER, LOCK, INT, #10, SS	2
5	200070384	SCREW, PAN, M5X0.8X14, PHL, ZN	2
6	630251	FITTING, PIPE, E90, PF12/PF12 (FORGED)	1
7	630252	FITTING, BRS, STR, PM12/PF06, BUSHING	1
8	150538	FITTING, PLSTC, STR, PM06/BM06	1
9	54333	CLAMP, HOSE, WORMDRIVE, 0.31-0.88D, .31W	6
10	630417	HOSE, 6.5" FR WAND PUMP/TEE	1

● RECOMMENDED STOCK ITEMS

REF	PART #	DESCRIPTION	QTY.
11	630372	FITTING, PLSTC, TEE, BM08/BM06/BM08	1
12	150516	FITTING, BRS, STR, BM06/PM04	1
13	630418	HOSE, 27.5" OF 376720	1
14	579029	NUT, HEX, STD, M6X1.0, DIN 934P	2
15	630256	BRACKET, MTG., Q.K CONN. 11GA	1
16	608292	●QUICK CONN. FEMALE 3/8"X1/4" NPT	1
17	150300	FITTING, BRS, STR, PF04/PF04, BH	1
18	608322	SCREW, TRS, M6X1.0X16, PHL, SS	2
19	578244000	WASHER M6.4X10 LCK SS	2
20	579210	WASHER, FLAT, M6.4X18X1.5, ZN	2
21	613511	TUBING, 1/2IDX3/4OD VINYL 611259 FT 0.212	1
22	613518	TUBING, 1/2IDX3/4OD VINYL 611259 FT 0.670	1

ES (EXTENDED SCRUB) PLUMBING GROUP

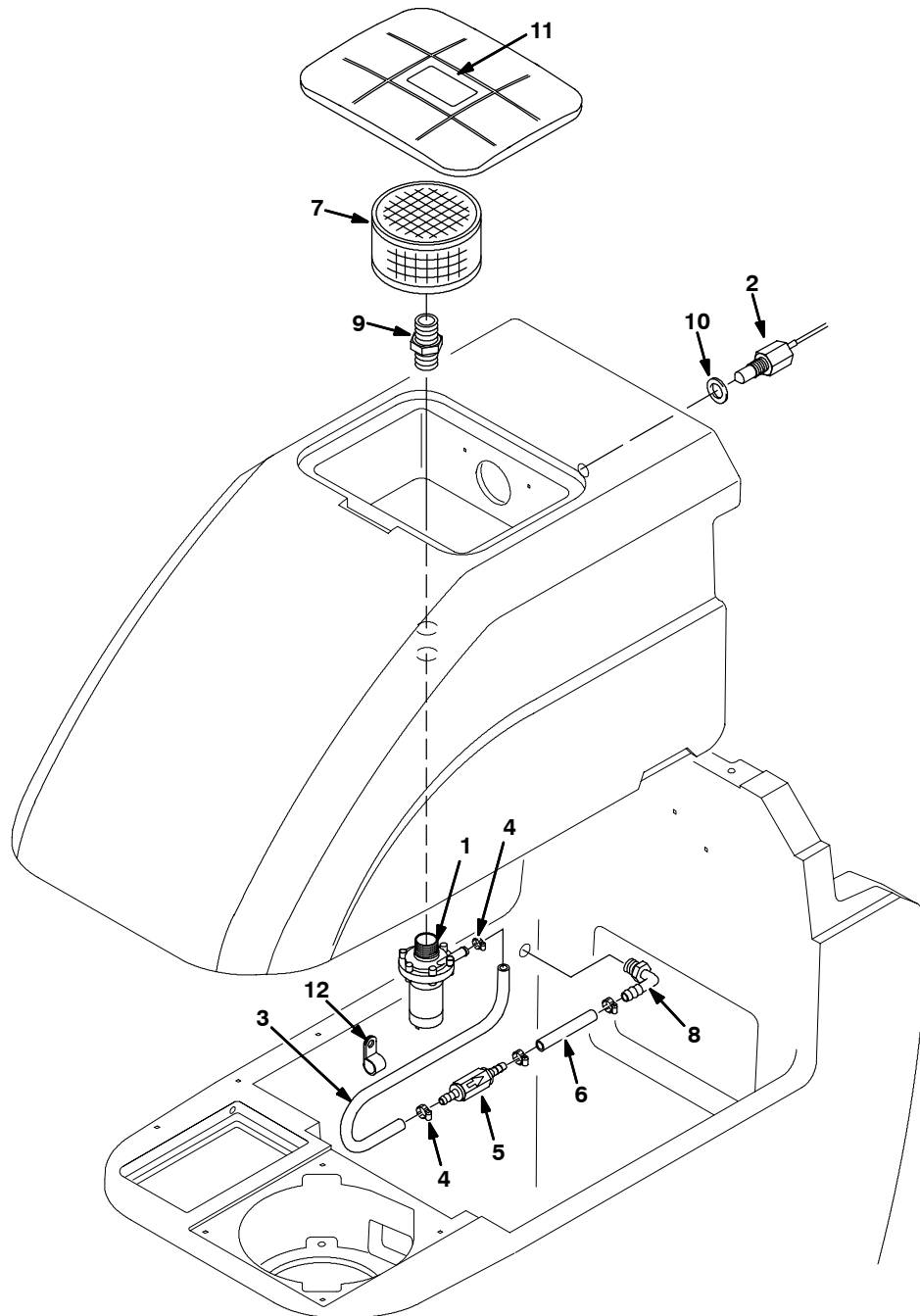

REF	PART #	DESCRIPTION	QTY.
1	630136	●PUMP, SOL, 24VDC 3/16" TERM 3/4"	1
2	630137	●SENSOR, LEVEL, LIQUID, 10-40VAC	1
3	606325	HOSE, 3/8IDX5/8ODX24" (376720)	1
4	54333	CLAMP, HOSE, WORMDRIVE, 0.31-0.88D, .31W	4
5	210044	●VALVE, CHECK, GPM 1PSI BM06/BM06	1
6	560497	HOSE, 6" OF RAW HOSE #25160	1

REF	PART #	DESCRIPTION	QTY.
7	630138	●FILTER, SCREEN, 100 MESH	1
8	150412	FITTING, PLSTC, E90 PM06/BM06	1
9	630385	FITTING, PLSTC, STR PM12/PM12 01.5L	1
10	630479	WASHER, FLAT, M17.5X25.4X3.2 NY	1
11	630440	DECAL, FILTER REMOVE	1
12	140314	CLAMP, CABLE, STL, 0.75DX0.75W, 1H, VYL	1

● RECOMMENDED STOCK ITEMS

SOUND KIT

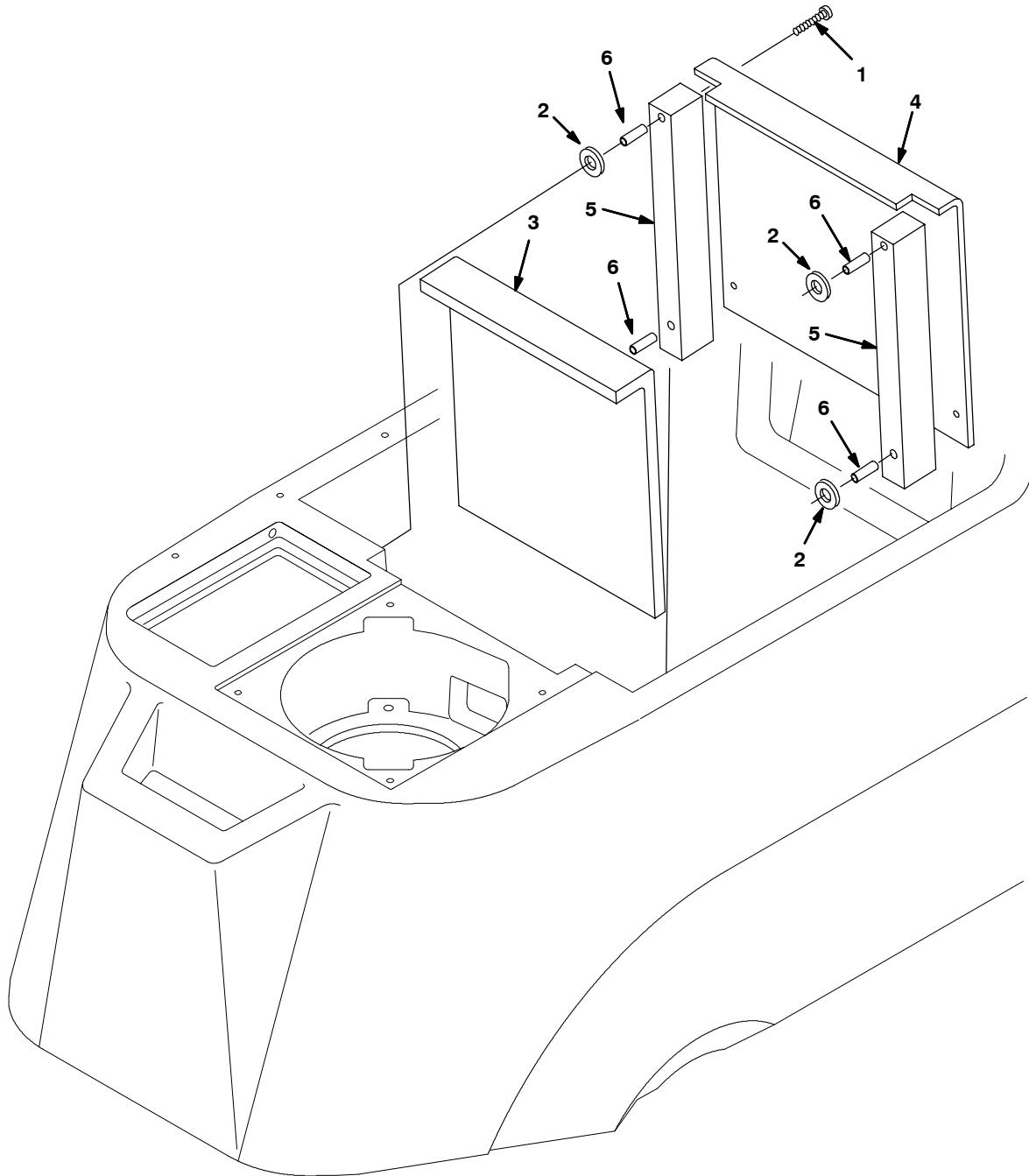

REF	PART #	DESCRIPTION	QTY.	
▽	630735	●KIT, SOUND, LOW DB	1	
▲	1	600393	SCREW, FLT, M5X0.8X40	4
▲	2	200315016	WASHER, FLAT, M5.3X15.0X1.6, ZN	4
▲	3	630441	SOUND FOAM, MAIN COVER	1

REF	PART #	DESCRIPTION	QTY.	
▲	4	630395	PLATE, COVER, SOUND	1
▲	5	630397	INSULATION, ACSTC, 10.3X1.1 C-O	2
▲	6	630398	SLEEVE, P/M, 0.315D 0.217B 0.98L STL PLT	4

▽ ASSEMBLY

▲ INCLUDED IN ASSEMBLY

● RECOMMENDED STOCK ITEMS