

34 RST, 34 RST EcoFlex™

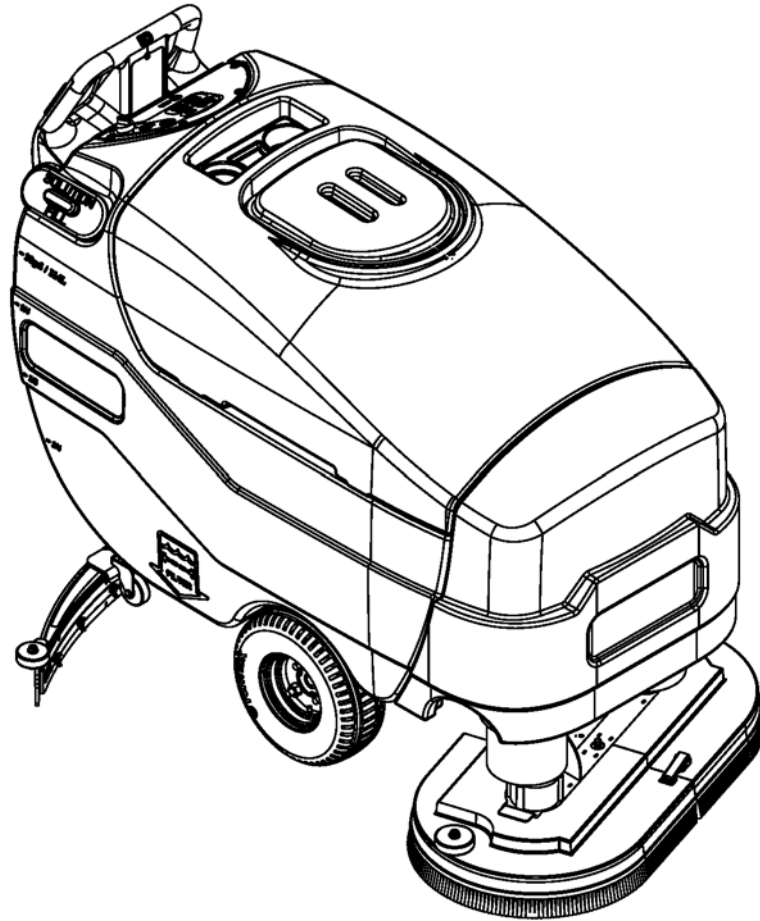

PARTS LIST

Standard Models:

56315900(34 RST D), 56315901(34 RST D-C)

56315902(34 RST D / W/Strainer)

56315903(34 RST D / W/Battery Watering),

56381809(34 RST D-C / W/Strainer)

EcoFlex Models:

56381029 (X34D), 56381031 (X34D-C)

<u>DESCRIPTION</u>	<u>PAGE</u>
Chassis System	2-3
Chassis System (Squeegee Linkage Assy)	4-5
Decal System.....	6-7
Recovery System.....	8-9
Scrub System	10-11
Solution / Electrical System (EcoFlex™)	12-15
Solution / Electrical System (STD).....	16-19
Chemical Assembly (EcoFlex™)	20-21
Handle Assembly	22-23
Squeegee Assembly	24-25
Wiring Diagram	26-27
Battery Watering System	28-29
Optional Kits & Accessories.....	30
Brush Selector Guide-Disk	31

WHEN ORDERING PARTS

- * Use the part numbers from the "Ref. No." columns in this parts list.
- * Specify the model and serial number of the machine.
- * Use the space below to record the model and serial number for future reference.

Model _____ Serial No. _____

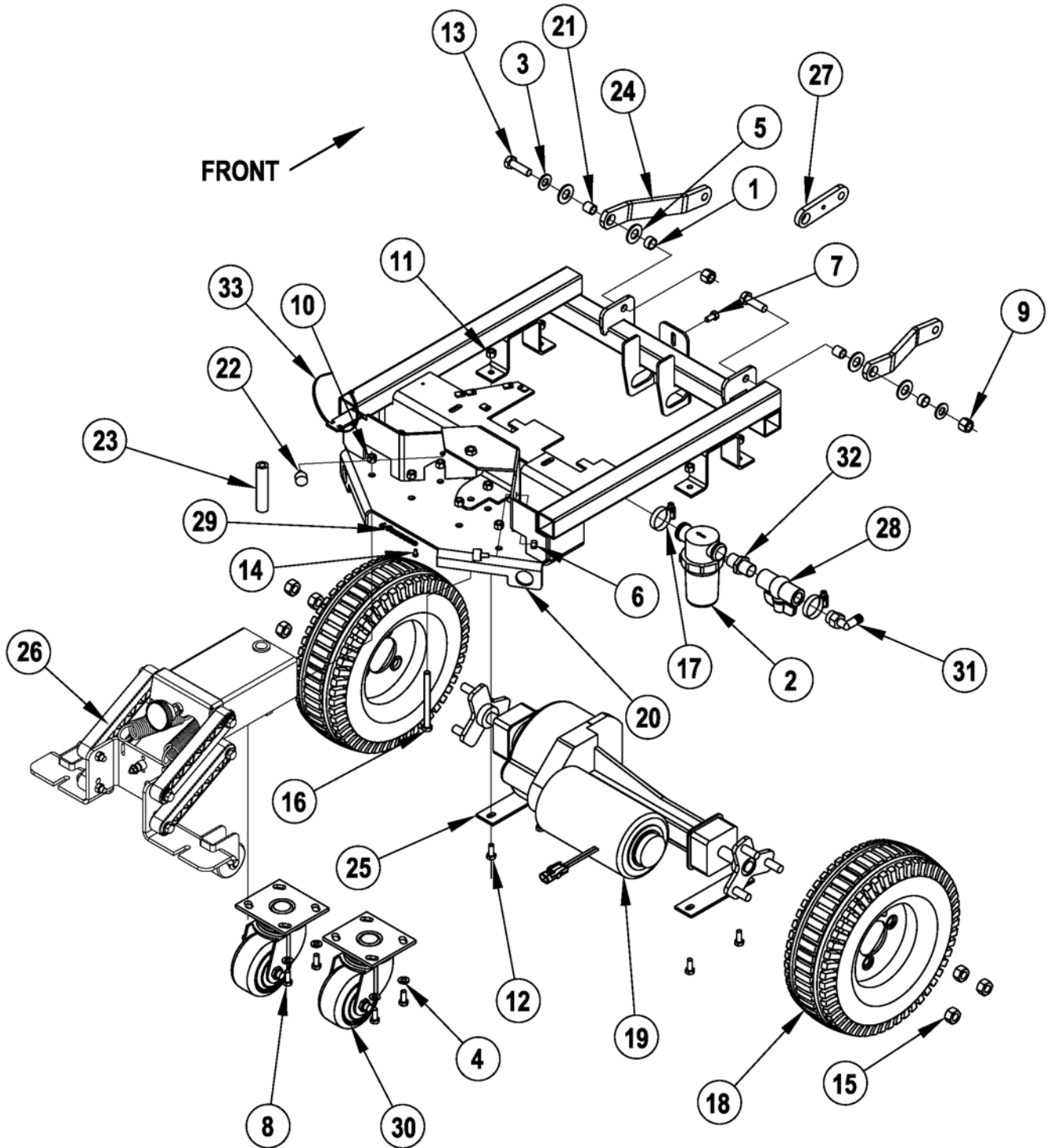

07-9	CHASSIS SYSTEM			
11-2	34 RST			3

Item	Ref. No.	Qty	Description
1	56370878	2	Bearing, Sleeve
2	56412173	1	Solution Filter
3	56001879	2	Wsh, Flt SAE 1/2
4	56001939	10	Wsh, Flt SAE 5/16
5	56002022	4	Wsh, Flt SAE 5/8
6	56002708	2	Nut, Hex Nyl Loc 1/4-20
7	56003012	3	Scr, Hex SS 5/16-18 X .75
8	56003179	8	Scr, Hex Thd To Hd M8-1.25 X 20mm
9	56003312	2	Nut, Hex Nyl Loc M12-1.75
10	56003389	8	Nut, Hex Nyl Loc M8-1.25
11	56003405	4	Nut, Hex Nyl Loc SS M8-1.25
12	56003435	4	Scr, Hex SS M8-1.25 X 20mm
13	56003637	2	Scr, Hex M12-1.75 X 40mm
14	56009030	1	Scr, Pan Phil Thd Form 10-24 X .38
15	56009116	6	Nut, Hex Hvy 1/2-20
16	56009241	1	Scr, Hex 3/8-16 X 4.25
17	56131601	2	Clamp, Hose SAE #16
18#	56315171	1	Kit, Drive Wheel TSBUS2010-1074 (Before February 2011)
18#	56315177	2	Wheel, Drive (After February 2011)
	9096219000	2	Wheel, Polyurethane-Traction (optional)
19	56315063	1	Transaxle, 36v (M1)
[]	56315676	1	Motor
[]	56315677	4	Carbon Brush
[]	56315678	2	Neoprene Mounting Sleeve
[]	56380511	A/R	Kit-Hub Transaxle 36V TSBUS2008-1023 / TSBUS2009-1042
[]#	56381779	1	Transaxle Service Kit
[]	56380161	1	Kit-Coupling
20	56315073	1	Weldment, Chassis
21	56315080	2	Bushing
22	56315111	2	Cylindrical Mount
23	56315154	1	Bushing, Spacer
24	56315918	2	Linkage Arm
25#	56315202	2	Plate, Transaxle Mount TSBUS2010-1074
26	56315210	1	Assembly, Squeegee Linkage Large
27	56315239	1	Linkage Arm,
28#	56381475	1	Ball Valve
29	56315691	1	Ground Chain
30	56365555	2	Caster Swivel 4.0x2.0
31	56409152	1	Barb, 90 Elbow 1/2 X 1/2npt
32	56412182	1	Nipple, Hex 3/4-14
33	56478523	1	Tie, Cable

[] = Not Shown

= Revised or new since last update

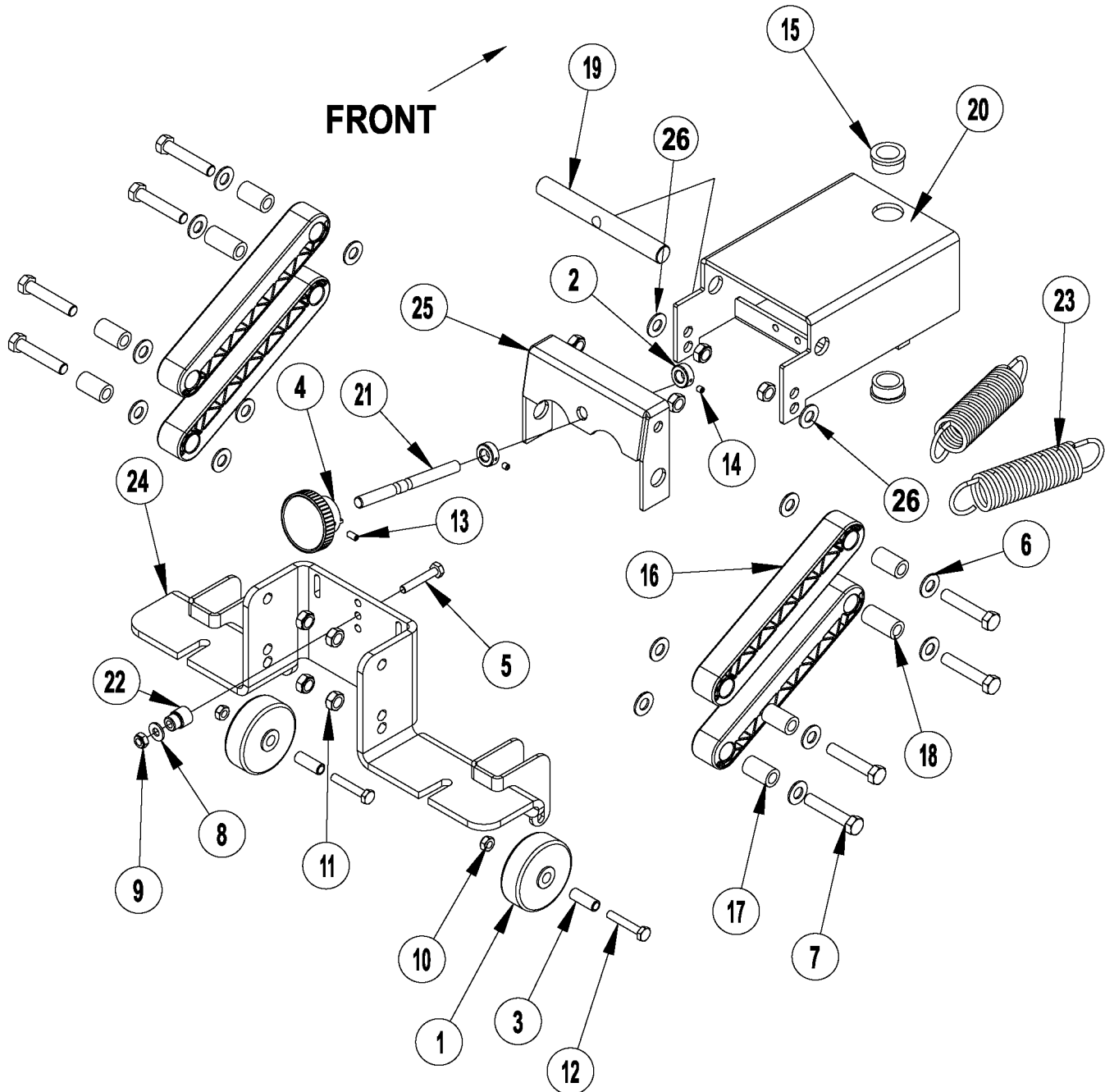

07-9	CHASSIS SYSTEM (squeegee linkage assy)		
10-2	34 RST		5

Item	Ref. No.	Qty	Description
	56315210	1	Squeegee Linkage Assembly
1	56324350	2	Wheel
2	56331076	2	Collar
3	56315580	2	Bushing
4	56475480	1	Knob
5	56001833	1	Scr, Hex 1/4-20 X 1.50
6	56002063	14	Wsh, Flt SAE 3/8
7	56002091	8	Scr, Hex 3/8-16 X 2.00
8	56002098	1	Wsh, Flt SAE 1/4
9	56002840	1	Nut, Hex Nyl Loc-Thin 1/4-20
10	56002850	2	Nut, Hex Nyl Loc-Thin SS 1/4-20
11	56002852	8	Nut, Hex Nyl Loc-Thin SS 3/8-16
12	56002880	2	Scr, Hex SS 1/4-20 X 1.75
13	56003123	1	Scr, Soc Set 10-2 4x .38
14	56009084	2	Scr, Soc Set Loc 10-24 X .19
15	56250414	2	Bearing, Flange
16	56315941	4	Linkage Arm, Molded
17	56315067	6	Spacer, Phenolic
18	56315068	2	Spacer, Phenolic
19	56315082	1	Pin
20	56315208	1	Weldment, Squeegee Large
21	56315240	1	Rod, Adjustment
22	56315245	1	Bushing, Squeegee Cable
23	56315295	2	Spring, Extension
24	56315698	1	Weldment, Squeegee Mount
25	56315713	1	Bracket, Squeegee Level
26	56002940	2	Wsh, Flt SAE SS 5/8

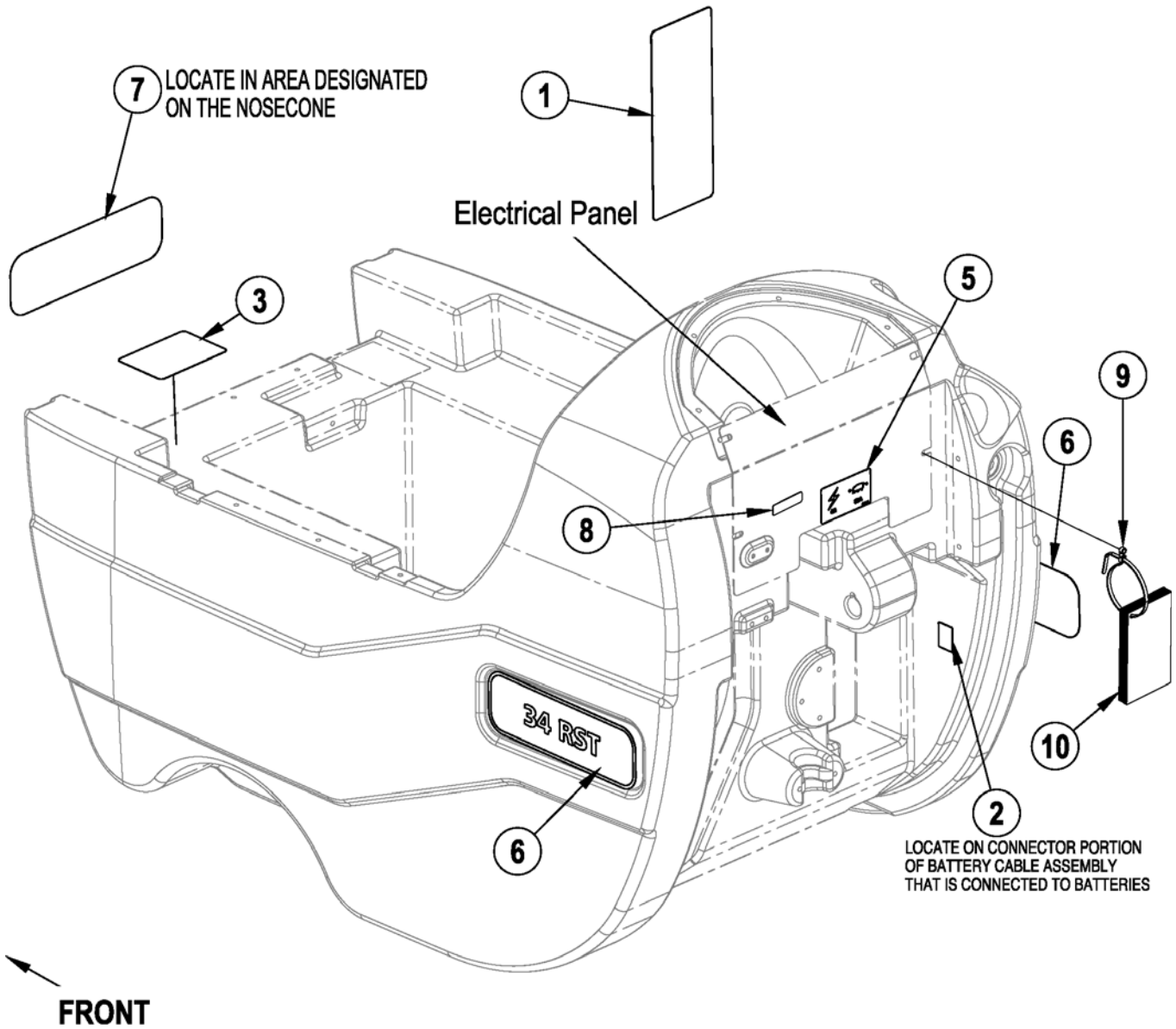

07-9	DECAL SYSTEM		
10-2	34 RST		7

Item	Ref. No.	Qty	Description
1	56014601	1	Decal, Caution
2	56016324	1	Decal, Charger
3	56015259	1	Decal, Battery Wiring
5	56016690	1	Decal, Circuit Breaker
6	56315919	2	Decal-34RST (STD models)
	56381115	2	Decal-34RST EcoFlex (EcoFlex models)
7	56016730	1	Decal, Advance
8	56014450	1	Decal, Patent Number
9	2-00-04937	1	Hose Tie W/Eyelet
10	L3018A	1	Instruction Booklet

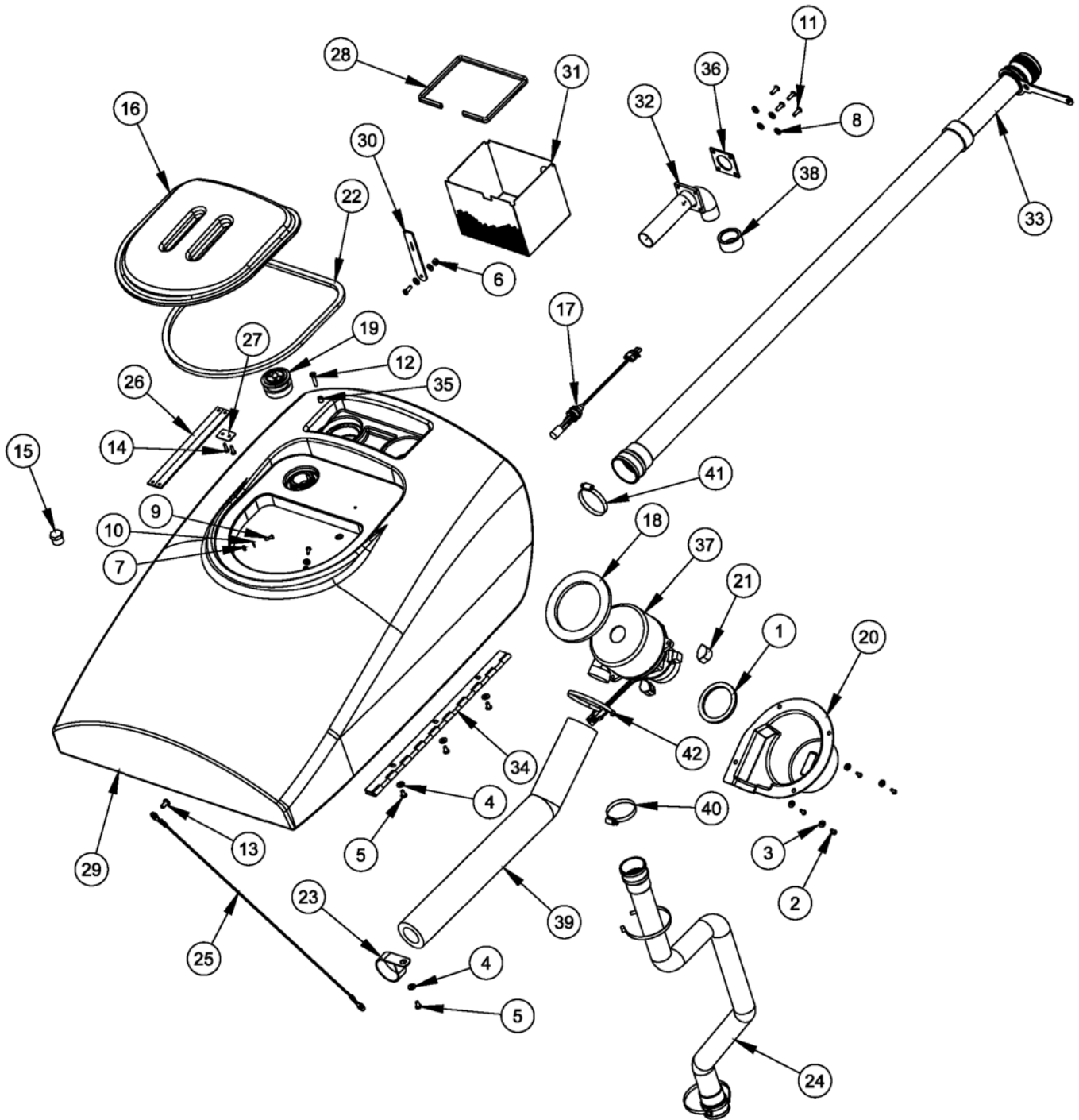

07-9	RECOVERY SYSTEM			
08-9	34 RST			9

Item	Ref. No.	Qty	Description
1	56412154	1	Gasket, Vacuum Duct
2	56001993	4	Scr, Pan Phil 10-24 X .50
3	56002053	4	Wsh, Flt STD #10
4	56002098	4	Wsh, Flt SAE 1/4
5	56002145	4	Scr, Pan Phil 1/4-20 X .50
6	56002491	2	Nut, Hex Nyl Loc SS 1/4-20 NOTE 1
7	56002849	2	Nut, Hex Nyl Loc-Thin SS 10-24
8	56002859	7	Wsh, Flt SAE SS 1/4 NOTE 1
9	56002896	2	Scr, Pan Phil SS 10-24 X .62
10	56002919	2	Wsh, Flt Std SS #10
11	56002957	5	Scr, Pan Phil SS 1/4-20 X .75 NOTE 1
12	56002958	1	Scr, Pan Phil SS 1/4-20 X 1.25 NOTE 1
13	56003003	1	Scr, Pan Phil 5/16-18 X .62
14	56009005	2	Scr, Pan Phil SS Type B 10-16 X .75
15	56305464	1	Plug, 3/4 Hex Pipe NOTE 2
16	56315176	1	Cover, Recovery Tank
17	56315096	1	Switch, Electromagnetic (S4)
18	56315098	1	Gasket
19	56315099	1	Screen, Fan Inlet
20	56315102	1	Shroud, Vac Motor
21	56315141	3	Mount, Vibration
22	56315220	1	Gasket, Recovery Lid
23	56315257	1	Clamp, P
24	56315268	1	Vac Hose Assy.
25	56315272	1	Cable Assy
26	56315303	2	Retaining, Strap
27	56315346	1	Plate
28	56315484	1	Trim, Edge NOTE 1
29	56315406	1	Tank, Recovery (std)
	56315407	1	Tank, Recovery NOTE 1
30	56315486	1	Strap, Linatex NOTE 1
31	56315487	1	Basket, Strainer NOTE 1
32	56315488	1	Adaptor, Hose Weldment NOTE 1
33	56601405	1	Drain Hose NOTE 3
*	56601411	1	Drain Hose Cap Kit
*	56601413	1	Drain Hose kit NOTE 3
**	56601410	1	Drain Hose Extension
34	56315694	1	Hinge
35	56321532	1	Bushing .25x.37x.40 NOTE 1
36	56380763	1	Gasket NOTE 1
37	56391208	1	Vac Motor Assy (M4)
[]	56377001	1	Carbon Brush Set of 2
38	56410446	1	Adapter NOTE 1
39	56315375	1	Foam, Acoustical
*	56315597	1	Sound Reduction Kit
40	56440213	1	Clamp, Hose SAE #32
41	56456797	1	Clamp, Hose SAE #36
42	56477613	3	Tie, Cable

[] = Not Shown

* = Optional, Not Included

NOTE 1: These items are only found on model 56315902 with the recovery tank strainer.

NOTE 2: Not used after March 2008.

NOTE 3: Drain Hose 56315638 has been replaced by Drain Hose 56601405 in production. When replacing 56315638 you need to order Drain Hose Kit 56601413.

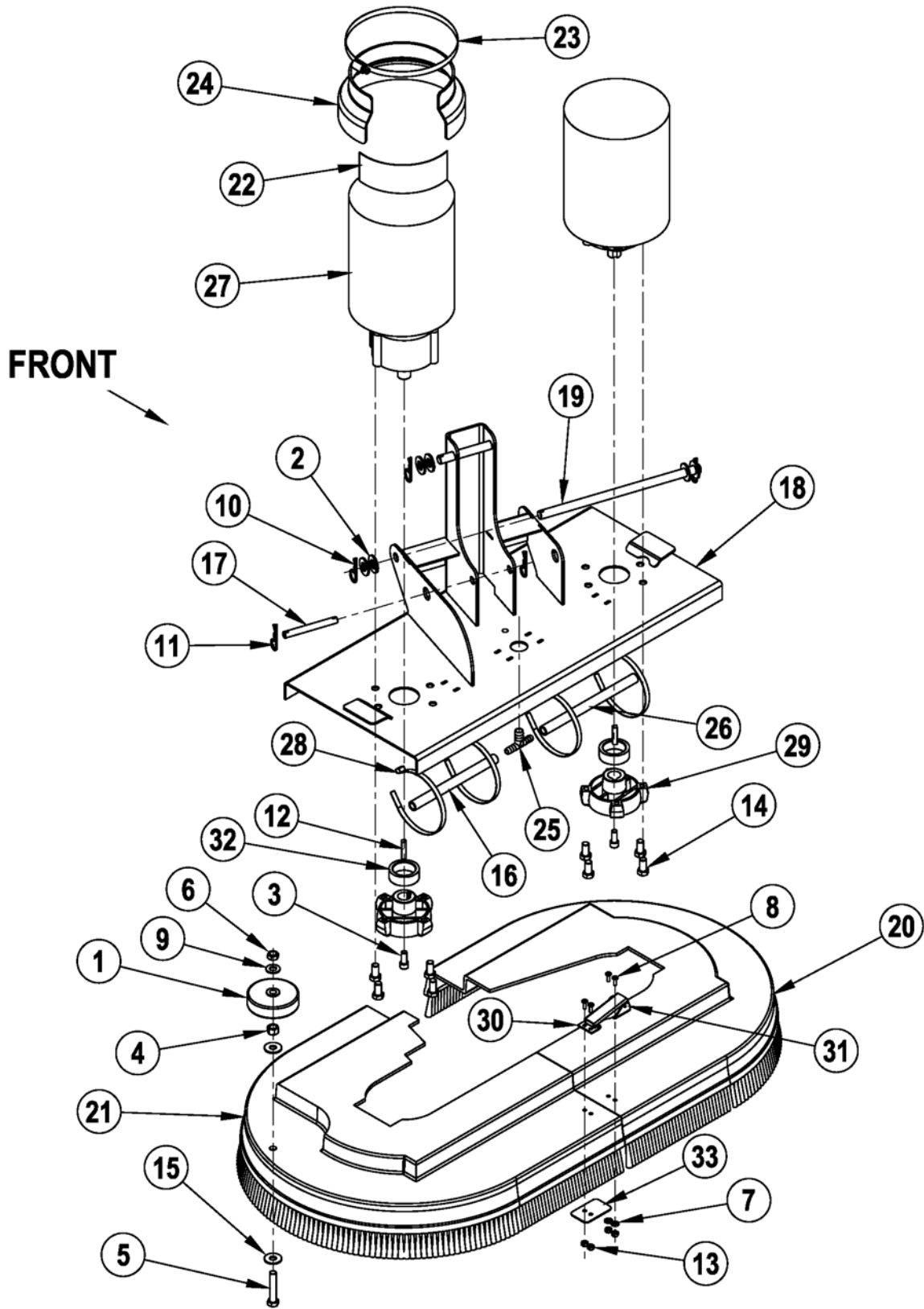

07-9	SCRUB SYSTEM		
10-10	34 RST		11

Item	Ref. No.	Qty	Description
1	56324499	1	Wheel 3.00
2	56001879	6	Wsh, Flt Sae 1/2
3	56001959	2	Scr, Soc Hd 5/16-18 X 0.75
4	56002123	1	Nut, Hex Machine 3/8-16
5	56002470	1	Scr, Hex Thd To Hd 3/8-16 X 2.00
6	56002841	1	Nut, Hex Nyl Loc-Thin 3/8-16
7	56002875	2	Wsh, Flt Sae Ss #8
8	56002876	4	Scr, Pan Phil Ss 8-32 X .50
9	56002910	1	Wsh, Flt Sae Ss 3/8
10	56002959	3	Pin, Cotter Hair
11	56003120	2	Pin, Cotter Hair .0915 X .375
12	56003245	2	Key, Sq .25 X 1.19
13	56003309	4	Nut, Hex Nyl Loc-Thin Ss 8-32
14	56003338	8	Scr, Hex Loc Ss 3/8-16 X .75
15	56009213	2	Wsh, Flt .392x1.00x.075
16	56315060	1	Hose, Pvc .38id X 6.75
17	56315161	1	Pin
18	56315910	1	Deck Weldment
19	56315915	1	Pin, Linkage Pivot
20	56315950	1	Brush Housing Lh
	56315955	1	Brush Housing Assy – Left (Items 7, 8, 13, 20, 31)
21	56315951	1	Brush Housing Rh
	56315956	1	Brush Housing Assy – Right (Items 1, 4, 5, 6, 8, 9, 13, 15, 21, 30, 33)
22	56315952	1	Decal, Cover
23	56355488	1	Clamp, Hose Sae #96
24	56397112	1	Shroud, Motor
25	56397300	1	Tee, Barb
26	56397301	1	Hose, Pvc .38id X 7.50
27	56397316	2	Motor / Gear Unit Assembly 36v (M2 / M3) TSBUS2010-1059
[]	56397139	4	Carbon Brush NOTE 1
[]	56397138	4	Brush Spring NOTE 1
[]	56380634	1	Carbon Brush/Set of 4 NOTE 1
[]	56380635	1	Brush Spring/Set of 4 NOTE 1
28	56477613	4	Tie, Cable
29	34400b	2	Gimble, Motor
30	55451a	1	Keeper, Latch
31	55721A	1	Draw Latch
32	61658a	2	Collar, Brush Driver
33	69186a	1	Tab, Latch, Brush
Optional Brushes			
[]	56315942	2	Pad Holder-17 Gimbal
[]	10384A	2	Brush, Light Grit
[]	11430B	2	Brush, Medium Grit
[]	11425B	2	Brush, Heavy Grit
[]	11424B	2	Brush, Polypropylene
[]	10875A	2	Brush, Nylon

[] = Not Shown

NOTE 1: If your Motor / Gear Unit Assembly has a serial tag from Imperial Electric order (4) Carbon Brushes 56397139 or (4) Brush Springs 56397138.
If your Motor / Gear Unit Assembly has a serial tag from Nilfisk-Advance order Carbon Brush Set 56380634 or Brush Spring Set 56380635.

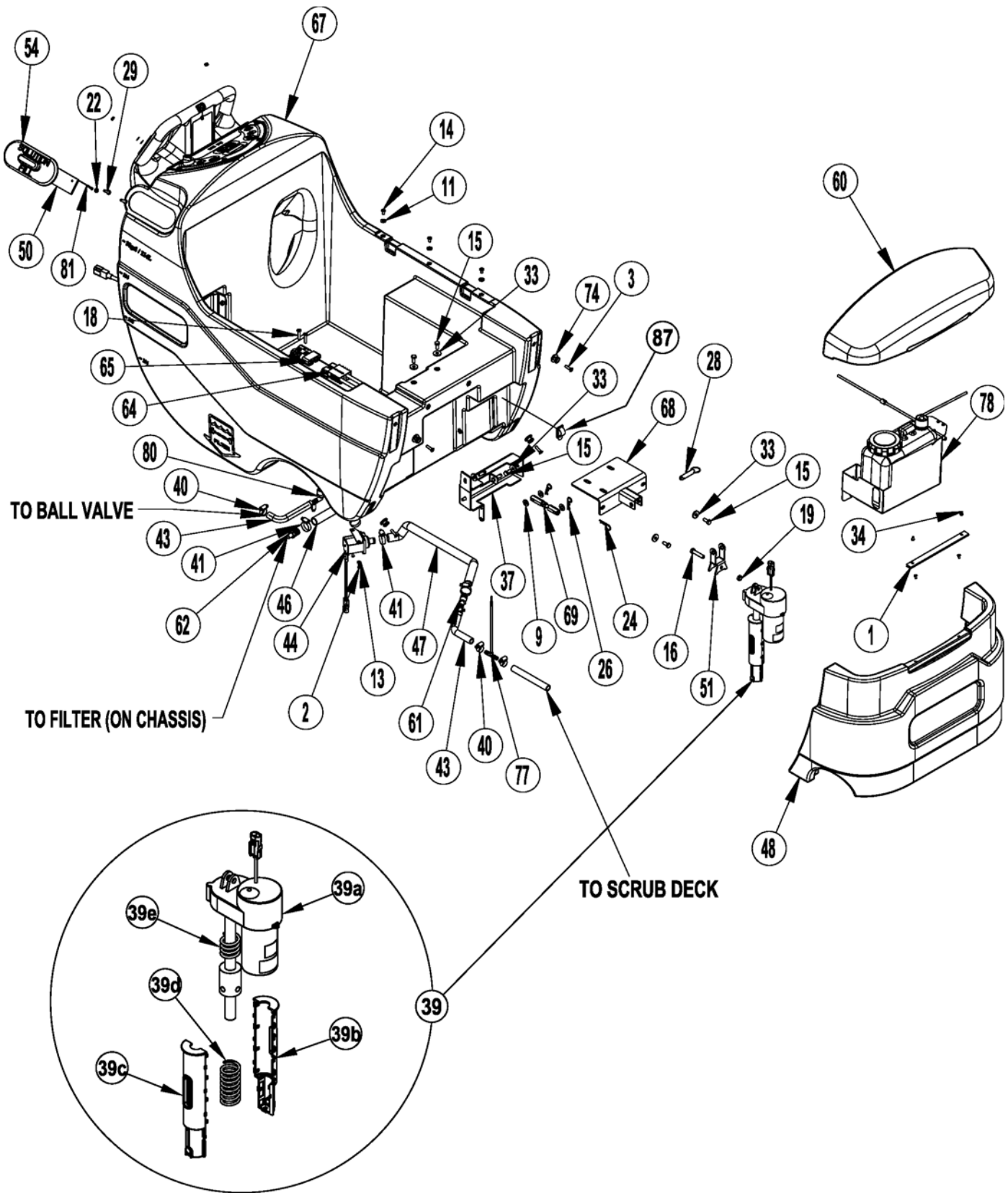

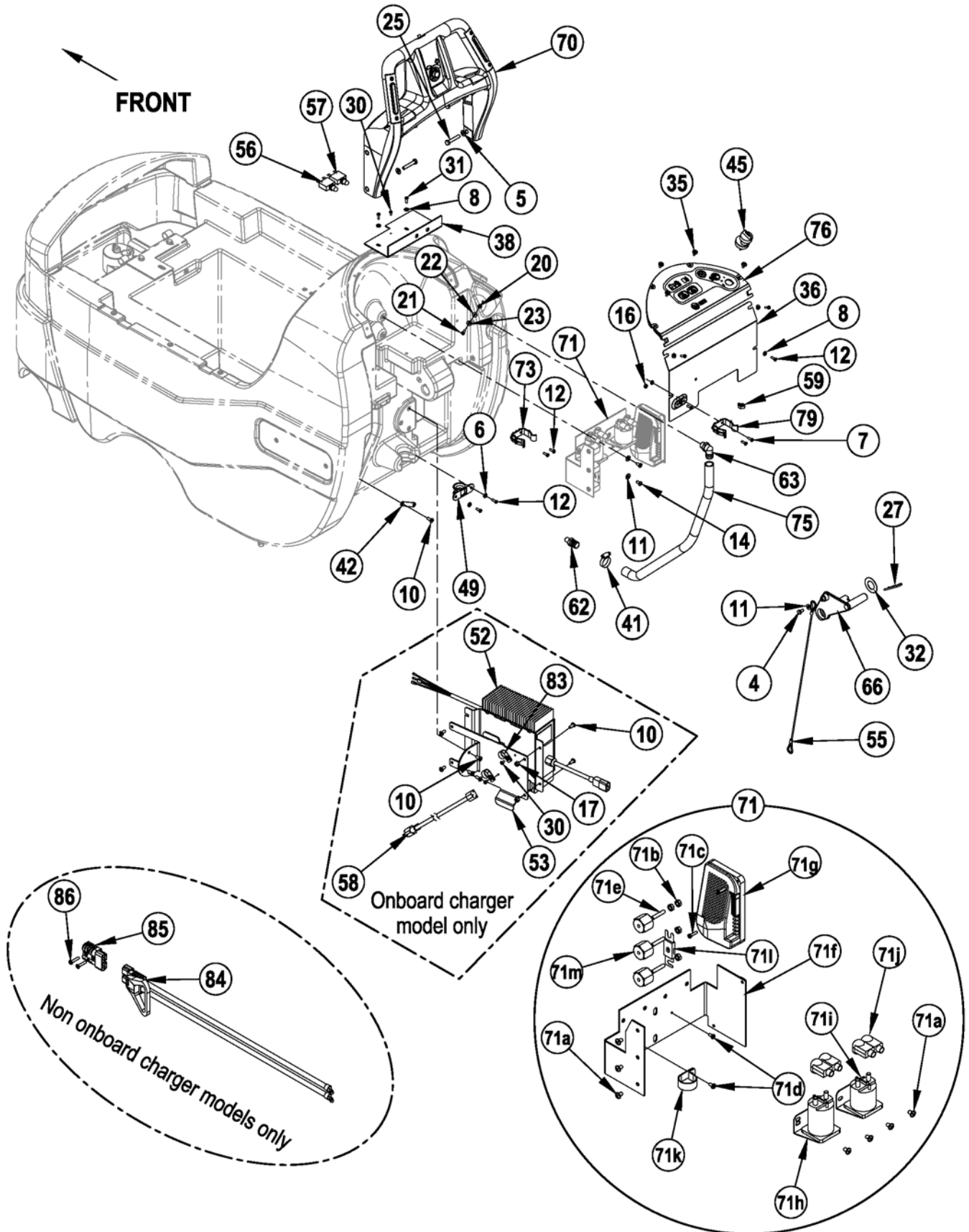

SOLUTION / ELECTRICAL SYSTEM (EcoFlex™)

07-9

14

34 RST

10-2

Item	Ref. No.	Qty	Description
1	56302168	1	Hinge
2	56001818	2	Scr-Pan Phil 8-32 X .38
3	56001832	4	Scr, Flt Phil 1/4-20 X 1.00
4	56001854	1	Scr, Hex 1/4-20 X .50
5	56001939	4	Wsh, Flt Sae 5/16
6	56001954	2	Wsh, Flt Sae #10
7	56001993	2	Scr-Pan Phil 10-24 X .50
8	56002053	6	Wsh, Flt Std #10
9	56002063	3	Wsh, Flt Sae 3/8
10	56002066	8	Scr-Pan Phil 1/4-20 X .62 NOTE 1
11	56002098	6	Wsh, Flt Sae 1/4
12	56002124	8	Scr-Pan Phil 10-24 X .62
13	56002140	2	Wsh, Flt Sae #8
14	56002145	5	Scr-Pan Phil 1/4-20 X .50
15	56002667	7	Scr, Hex 5/16-18 X .75
16	56002684	1	Scr, Hex 3/8-16 X 1.75
17	56002708	4	Nut, Hex Nyl Loc 1/4-20 NOTE 1
18	56002825	2	Scr-Pan Phil 1/4-20 X 1.25 NOTE 1
19	56002841	1	Nut, Hex Nyl Loc-Thin 3/8-16
20	56002849	1	Nut, Hex Nyl Loc-Thin Ss 10-24
21	56002896	1	Scr, Pan Phil Ss 10-24 X .62
22	56002916	2	Wsh, Flt Sae Ss #10
23	56002919	1	Wsh, Flt Std Ss #10
24	56002959	1	Pin, Cotter Hair
25	56003005	4	Scr, Hex 5/16-18 X 1.75
26	56003120	2	Pin, Cotter Hair .0915 X .375
27	56003223	1	Pin, Cot Hair .148 X Dia .62/1.00
28	56003679	1	Pin, Ring .50 X 1.63
29	56009006	2	Scr,Pan Phil Ss Type Ab 10-16x1.00
30	56009030	3	Scr, Pan Phil Thd Form 10-24 X .38 NOTE 1
31	56009039	2	Scr, Hex Thd Form 10-24 X .50
32	56009117	1	Wsh, Flt 1.031 X 1.859 X 0.48
33	56009122	7	Wsh, Flt .344 X .938 X .125
34	56009139	4	Scr, Pan Phil Loc 10-24 X .38
35	56009206	4	Scr, Truss Phil-Blk 10-24x.50
36	56109502	1	Panel Electical Assy
37	56109524	1	Pivot Weldment
38	56109553	1	Plate Circuit Breaker
39	56109595	1	Lift Actuator Assembly
39a	56109597	1	Actuator
[]	56109596	1	Plastic Nut
[]	56109636	1	Spring Housing Kit
39b	56109547	1	Spring Housing Bottom
39c	56109546	1	Spring Housing Top
39d	56420018	1	Compression Spring
39e	56412071	1	Compression Spring
40	56219932	5	Clamp- Hose Sae #6
41	56244969	5	Clamp- Hose Sae #12
42	56249884	1	Plate
43	56262561	3	Hose, Spiral .500
44	56303275	1	Solenoid Valve Assy
45	56303553	1	Key Switch Assembly

Item	Ref. No.	Qty	Description
46	56305318	1	Hose, Spiral .750 X 10.5"
47	56305591	1	Hose, Spiral .750 X 25"
48	56315087	1	Nose Cone
49	56315121	1	Guide, Cable
50	56315166	1	Plate
51	56315191	1	Yoke, Actuator
52	56315204	1	Charger, On-Board 36v NOTE 1 / NOTE 3 TSBUS2007-979 / TSBUS2008-984 TSBUS2008-1003 / TSBUS2008-1008
53	56315206	1	Bracket, Charger NOTE 1
54	56315219	1	Cover, Solution Fill
55	56315243	1	Cable Assy
56	56315255	1	Circuit Breaker, 5 Amp
57	56315256	1	Circuit Breaker, 30 Amp
58	56315270	1	Charger Cord, Us NOTE 1
59	56315382	1	Clip, Conduit
60	56315609	1	Cover, Chemical Tank
61	56315625	1	Barb, Coupler 1/2 X 3/4
62	56315634	2	Barb, Adaptor 3/4 X 1/2 Npt
63	56315683	1	Barb, 90 Elbow 3/4 X 3/8npt
64	56315686	1	Charge Connector Assy (to batteries) NOTE 1
65	56315687	1	Charge Connector Assy (to electrical box) NOTE 1
66	56315730	1	Lever, Squeegee Lift
67	56315733	1	Tank, Solution
68	56315744	1	Weldment, Actuator Mount
69	56315836	1	Turnbuckle Assy
70	56315930	1	Handle Assembly
71	56315947	1	Assembly-Electrical Box
71a	56002462	7	Scr, Pan Phil 1/4-20 X .38
71b	56002561	4	Nut, Hex W/ Shprf 1/4-20
71c	56003698	2	Scr, Pan Phil Thd Form 8-32 X .75
71d	56009030	2	Scr, Pan Phil Thd Form 10-24 X .38
71e	56009203	3	Stud, 1/4-20
71f	56315182	1	Panel, Electrical
71g	56315925	1	Controller, Speed (A2)
71h	56395453	1	Contactor 36v, 200 Amp (K1 / Brush Motor) TSBUS2008-1020
71i	56395455	1	Contactor 36v, 100 Amp (K2 / Vac Motor)
71j	2-00-04203	4	Insulator, Terminal
71k	56380544	1	Clamp, .875 P
71l	56412089	1	Fuse, 150 Amp (F1)
71m	56469858	3	Standoff, Insulated
72	56325219	1	Tie, Cable
73	56331154	1	Clamp, Plastic
74	56365777	4	Lug, Brush Driver
75	56379139	1	Hose, Pvc
76	56381082	1	Control Panel Assy
77	56381099	1	Tee Assembly
78	56381104	1	Chemical Tank Assy
79	56396199	1	Clamp, Plastic
80	56409152	1	Barb, 90 Elbow 1/2 X 1/2npt
81	56410254	1	Wire Rope, 6 Inch
83	56486112	2	Clamp-P NOTE 1
84	56398000	1	Connector Assy (to batteries) NOTE 2
85	56315687	1	Connector Assy (to electrical box) NOTE 2
86	56002825	2	Scr, Pan Phil 1/4-20 x 1.25 NOTE 2
87	7-13-07096	1	Clamp-Adjustable

NOTE 1: These items are only used on model 56381031.

NOTE 2: These items are only used on model 56381029.

NOTE 3: The charger software can be programmed with a computer and the QuiQ Programmer kit 56315732.

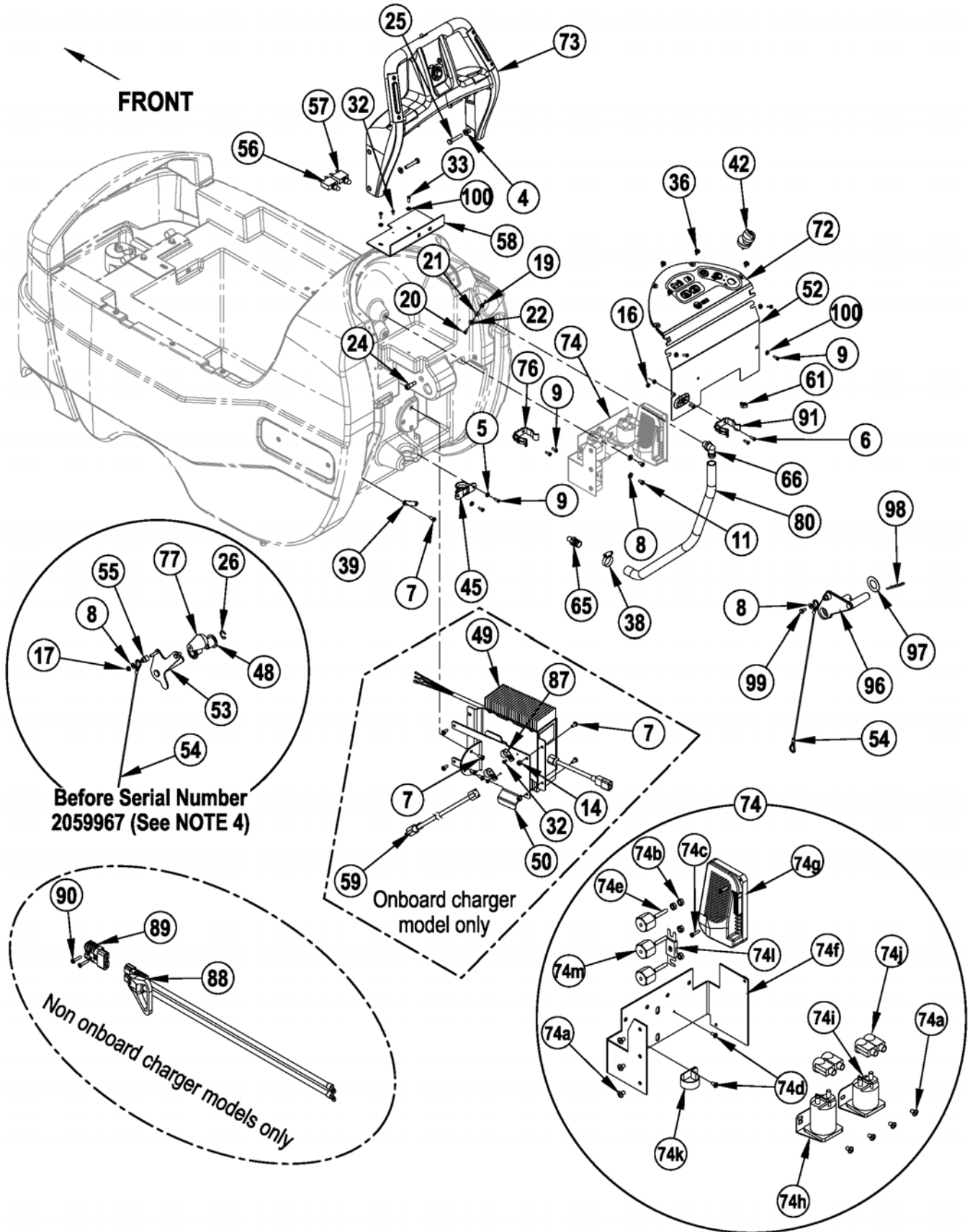

SOLUTION / ELECTRICAL SYSTEM (STD)

07-9

18

34 RST

10-2

Item	Ref. No.	Qty	Description	Item	Ref. No.	Qty	Description
1	56001818	2	Scr, Pan Phil 8-32 X .38	33	56009039	2	Scr, Hex Thd Form 10-24 X .50
2	56001832	4	Scr, Flt Phil 1/4-20 X 1.00	34	56009087	1	Nut, Hex Jam 1/4-20 NOTE 6
3	56001879	1	Wsh, Flt Sae 1/2 NOTE 6	35	56009122	7	Wsh, Flt .344 X .938 X .125
4	56001939	4	Wsh, Flt Sae 5/16	36	56009206	4	Scr, Truss Phil-Blk 10-24x.50
5	56001954	2	Wsh, Flt Sae #10	37	56219932	3	Clamp, Hose Sae #6
6	56001993	2	Scr, Pan Phil 10-24 X .50	38	56244969	5	Clamp, Hose Sae #12
7	56002066	8	Scr, Pan Phil 1/4-20 X .62 NOTE 1	39	56249884	1	Plate
8	56002098	6	Wsh, Flt Sae 1/4	40	56262561	1	Hose, Spiral .500
9	56002124	8	Scr, Pan Phil 10-24 X .62	41	56303275	1	Solenoid Valve Assy (L1)
10	56002140	2	Wsh, Flt Sae #8	42	56303553	1	Key Switch Assembly (S3)
11	56002145	5	Scr, Pan Phil 1/4-20 X .50	[]	56303526	A/R	Set of 2 Keys (for 56303553)
12	56002667	7	Scr, Hex 5/16-18 X .75	43	56305318	1	Hose, Spiral .750 X 10.5"
13	56002684	1	Scr, Hex 3/8-16 X 1.75	44	56305591	1	Hose, Spiral .750 X 25"
14	56002708	4	Nut, Hex Nyl Loc 1/4-20 NOTE 1	45	56315121	1	Guide, Cable
15	56002825	2	Scr, Pan Phil 1/4-20 X 1.25 NOTE 1	46	56315166	1	Plate
16	56002832	2	Nut, Hex Nyl Loc-Thin 10-24 NOTE 5	47	56315191	1	Yoke, Actuator
17	56002840	1	Nut, Hex Nyl Loc-Thin 1/4-20 NOTE 4	48	56315193	2	Bushing, Flange NOTE 4
18	56002841	1	Nut, Hex Nyl Loc-Thin 3/8-16	49	56315204	1	Charger, On-Board 36v NOTE 1 / NOTE 3
19	56002849	1	Nut, Hex Nyl Loc-Thin Ss 10-24				TSBUS2007-979 / TSBUS2008-984
20	56002896	1	Scr, Pan Phil Ss 10-24 X .62				TSBUS2008-1003 / TSBUS2008-1008
21	56002916	2	Wsh, Flt Sae Ss #10	[]	56315747	1	Thermistor Repair Kit (for 56315204)
22	56002919	1	Wsh, Flt Std Ss #10	50	56315206	1	Bracket, Charger NOTE 1
23	56002959	1	Pin, Cotter Hair	51	56315219	1	Cover, Solution Fill
24	56002962	1	Scr, Soc Shd .38 X .62 X 5/16-18 NOTE 4	52	56109502	1	Panel, Electrical NOTE 5
25	56003005	4	Scr, Hex 5/16-18 X 1.75	53	56315236	1	Weldment, Squeegee Lift TSBUS2008-1021
26	56003266	1	Ring, Ret Ext Type E 0.75 Dia NOTE 4	54	56315243	1	Cable Assy
27	56003312	1	Nut, Hex Nyl Loc M12-1.75 NOTE 6	55	56315245	1	Bushing, Squeegee Cable NOTE 4
28	56003679	1	Pin, Ring .50 X 1.63	56	56315255	1	Circuit Breaker, 5 Amp (F2)
29	56003708	1	Scr, Hex M12-1.75 X 55mm NOTE 6	57	56315256	1	Circuit Breaker, 30 Amp (F3)
30	56003709	1	Scr, Hex Thd To Hd 1/4-20 X 1.50 NOTE 6	58	56109553	1	Plate, Circuit Breaker NOTE 7
31	56009006	2	Scr, Pan Phil SS Type Ab 10-16 X 1.00	59	56315270	1	Charger Cord, Us NOTE 1
32	56009030	3	Scr, Pan Phil Thd Form 10-24 X .38 NOTE 1	60	56315380	1	Bushing NOTE 6
				61	56315382	1	Clip, Conduit
				62	56315479	1	Bushing NOTE 6
				64	56315625	1	Barb, Coupler 1/2 X 3/4
				65	56315634	2	Barb, Adaptor 3/4 X 1/2 Npt

Item	Ref. No.	Qty	Description	Item	Ref. No.	Qty	Description
66	56315683	1	Barb, 90 Elbow 3/4 X 3/8npt	80	56379139	1	Hose, Pvc
67	56315686	1	Charge Connector Assy	81	56387302	1	Hose, Solution
68	56315687	1	Charge Connector Assy	82	56109595	1	Lift Actuator Assembly (82a-82e) NOTE 9 / TSBUS2009-1040
69	56315733	1	Tank, Solution	82a	56109597	1	Actuator
*	56109560	1	Solution Tank Kit NOTE 8	[]	56109596	1	Plastic Nut
70	56315736	1	Pivot Weldment NOTE 6	[]	56109636	1	Spring Housing Kit
71	56315744	1	Weldment, Actuator Mount	82b	56109547	1	Spring Housing Bottom
72	56315924	1	Control Panel Assy	82c	56109546	1	Spring Housing Top
73	56315930	1	Handle Assembly	82d	56420018	1	Compression Spring
74	56315947	1	Assembly, Electrical Box (74a-74m)	82e	56412071	1	Compression Spring
74a	56002462	7	Scr, Pan Phil 1/4-20 X .38	83	56409152	1	Barb, 90 Elbow 1/2 X 1/2npt
74b	56002561	4	Nut, Hex W/ Shprf 1/4-20	84	56410254	1	Wire Rope, 6 Inch
74c	56003698	2	Scr, Pan Phil Thd Form 8-32 X .75	87	56486112	2	Clamp,P NOTE 1
74d	56009030	2	Scr, Pan Phil Thd Form 10-24 X .38	88	56398000	1	Connector Assy (to batteries) NOTE 2
74e	56009203	3	Stud, 1/4-20	89	56315687	1	Connector Assy (to electrical box) NOTE 2
74f	56315182	1	Panel, Electrical	90	56002825	2	Scr, Pan Phil 1/4-20 x 1.25 NOTE 2
74g	56315925	1	Controller, Speed (A2)	91	56396199	1	Clamp, Plastic
74h	56395453	1	Contacto 36v, 200 Amp (K1 / Brush Motor)	92	56109524	1	Pivot Weldt. NOTE 6
			TSBUS2008-1020	93	56003120	2	Pin, Cotter Hair .0915 x .375 NOTE 6
74i	56395455	1	Contacto 36v, 100 Amp (K2 / Vac Motor)	94	56315836	1	Turnbuckle NOTE 6
74j	2-00-04203	4	Insulator, Terminal	95	56002063	3	Wsh, Flt SAE 3/8 NOTE 6
74k	56380544	1	Clamp, .875 P	96	56315730	1	Lever, Squeegee Lift TSBUS2008-1021 / NOTE 4
74l	56412089	1	Fuse, 150 Amp (F1)	97	56009117	1	Wsh, Flt 1.03 x 1.85 x .48 NOTE 4
74m	56469858	3	Standoff, Insulated	98	56003223	1	Pin, Cot Hair NOTE 4
75	56315949	1	Nose Cone, One Piece	99	56001854	1	Scr, Hex 1/4-20 x .50 NOTE 4
76	56331154	1	Clamp, Plastic	100	56002053	6	Wsh, Flt STD #10
77	56364527	1	Knob NOTE 4	101	7-13-07096	1	Clamp-Adjustable
78	56365777	4	Lug, Brush Driver	[]	56325219	1	Tie, Cable
79	56370878	1	Bearing, Sleeve NOTE 6				

[] = Not Shown

NOTE 1: These items are only used on model 56315901.
NOTE 2: These items are only used on model 56315900.
NOTE 3: The charger software can be programmed with a computer and the QuiQ Programmer kit 56315732.
NOTE 4: As of serial number 2059967 the following items (56002962, 56364527, 56002840, 56003266, 56315193, 56315236 & 56315245) are no longer used in production. If you need to replace any of these items please order the following group of parts (56315730, 56009117, 56003223, 56001854 / items 96 through 99) in a quantity of 1 each.
NOTE 5: As of serial number 2059967 the following items (56002832, 56315222 & 56412285) are no longer used in production. If you need to replace 56315222 or 56412285 please order 56109502.
NOTE 6: As of October 2008 the following items (56370878, 56001879, 56003312, 56003708, 56315736, 56315380, 56315479, 56003709, 56009087) are no longer used in production. If you need to replace any of these items please order Kit 56109540.
NOTE 7: 56315259 and 56315532 are no longer used in production. If you need to replace either of these items please order 56109553.
NOTE 8: If replacing the solution tank on a machine with the old style squeegee lift level (56315236), please order Solution Tank Kit 56109560.
NOTE 9: Actuator 56109595 replaces actuator 56396049 as of September 2009.

07-9	CHEMICAL ASSEMBLY (EcoFlex™)		
10-2	34 RST		21

Item	Ref. No.	Qty	Description
	56381104	1	Chemical Tank Assy
1	56002877	2	Nut, Hex Nyl Loc SS 8-32
2	56003018	2	Scr, Pan Phil SS 8-32 X .38
3	56003699	1	Bushing, 1/4 Id Snub
4	56315241	1	Pump, Chemical
5	56315644	1	Bracket, Tank Mounting
6	56315382	2	Clip, Conduit
7	56315476	1	Bracket, Chemical Pump
8	56601544	1	Chemical Bottle Assy
**	56601545	A/R	Chemical Bottle Assy (8, 9, 13)
9	56315517	1	Cap, Raw
10	56315522	1	Check Valve, 1/8 Barb, 125 PSI
11	56315523	1	Cap, Dry Break, 1/8 Barb, 90°
12	56315524	3	Hose, Chemical Resistant, 7"
13	56315527	1	Insert, Dry Break

** = Optional, Not Included

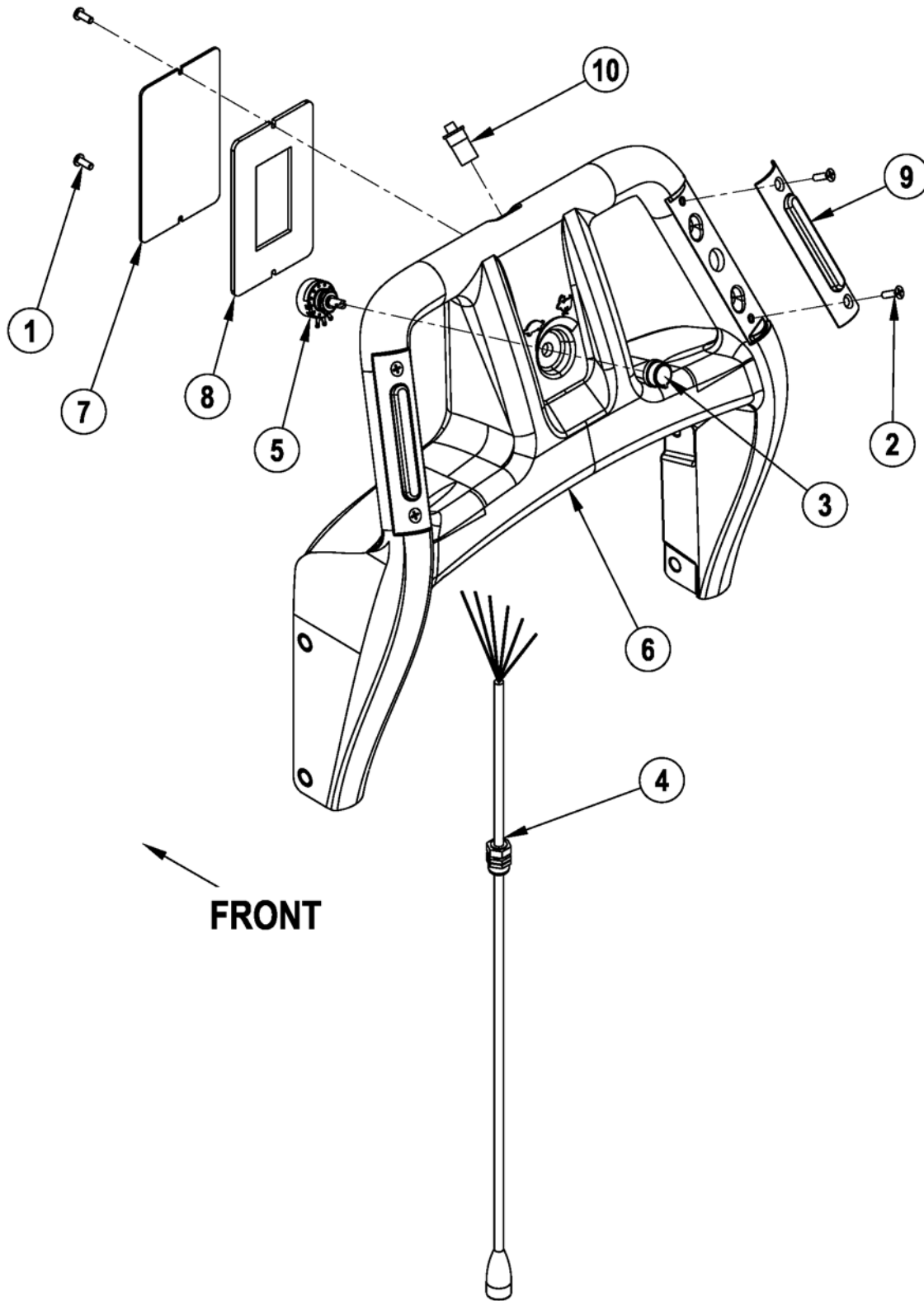

Item	Ref. No.	Qty	Description
	56315930	1	Handle Assembly
1	56002043	2	Scr, Pan Phil 10-24 X .38
2	56002178	4	Scr, Flt Phil 10-24 X .50
3	56315280	1	Knob
4	56315928	1	Harness, Handle
5	56315929	1	Potentiometer, 100k (R1)
6	56315931	1	Handle, Rotomold
7	56315932	1	Access Plate
8	56315933	1	Gasket, Access Panel
9	56315935	2	Palm Switch Assembly (S6 / S7)
10	56315945	1	Switch, Spst Mom. (S5)

SQUEEGEE ASSEMBLY

07-9

24

34 RST

09-8

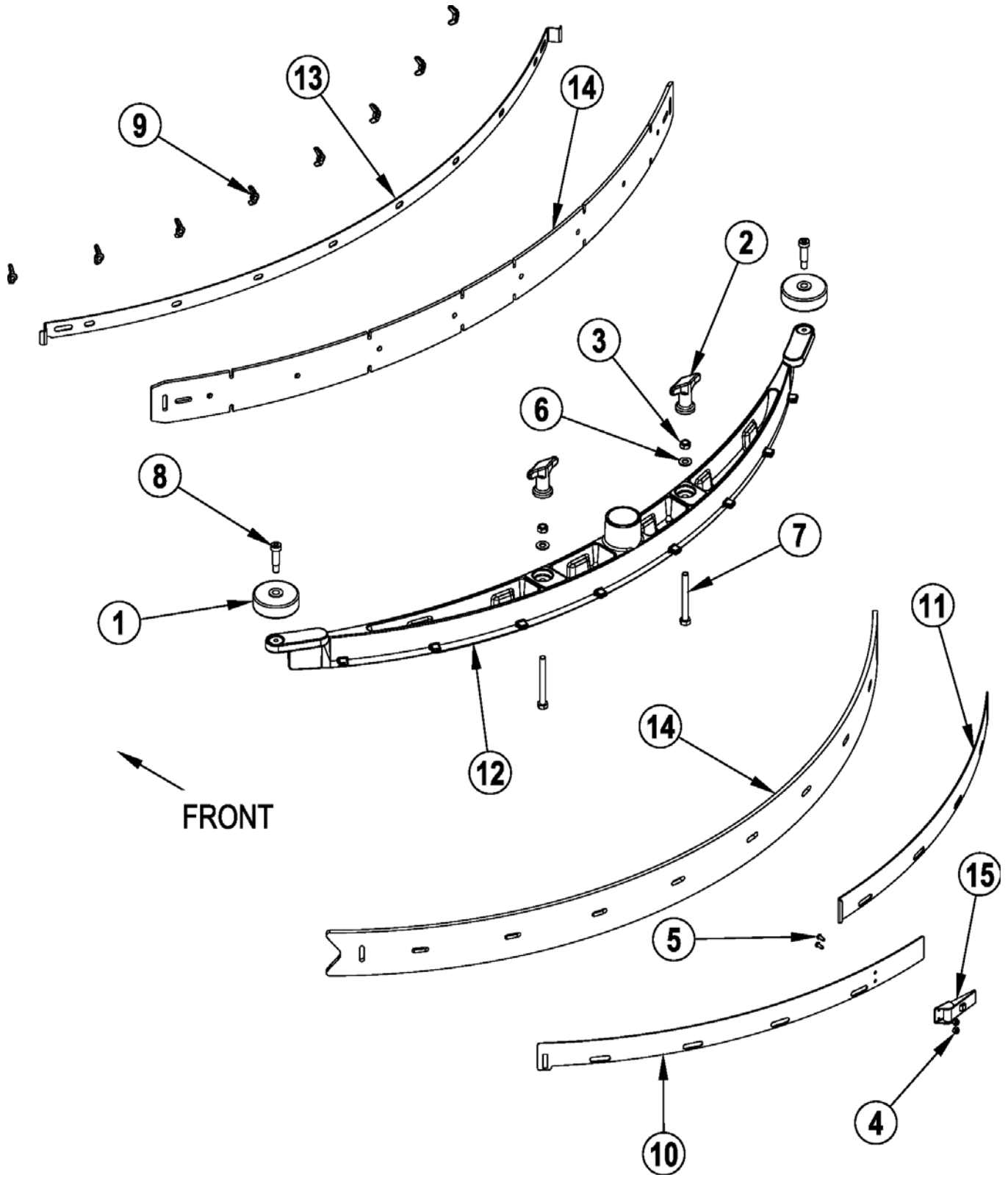

Item	Ref. No.	Qty	Description
	56315632	1	Squeegee Assembly "D" (STD) NOTE 2
	56315290	1	Squeegee Assembly "C" (Narrow Isle Option) NOTE 2
1	56324350	2	Wheel
2	56370711	2	Nut, Thumb
3	56002851	2	Nut, Hex Nyl Loc-Thin Ss 5/16-18
4	56002907	2	Nut, Hex Nyl Loc SS 6-32
5	56002909	2	Scr, Pan Phil SS 6-32 X .38
6	56002938	2	Wsh, Flt Sae SS 5/16
7	56003736	2	Scr, Hex Thd to Hd SS 5/16-18 X 3.00
8	56003472	2	Scr, Soc Shd .38 X 1.00 X 5/16-18
9	56009111	8	Nut, Wing SS 1/4-20
10	56109667	1	Strap, Left Rear "D" (used on 56315632) NOTE 2 / TSBUS2009-1037
	56109664	1	Strap, Left Rear "C" (used on 56315290) NOTE 2 / TSBUS2009-1037
11	56109668	1	Strap, Right Rear "D" (used on 56315632) NOTE 2 / TSBUS2009-1037
	56109665	1	Strap, Right Rear "C" (used on 56315290) NOTE 2 / TSBUS2009-1037
12	56314694	1	Squeegee Tool, Cast "D" (used on 56315632)
	56314325	1	Squeegee Tool, Cast "C" (used on 56315290)
13	56314696	1	Strap, Front "D" (used on 56315632) NOTE 2
	56314322	1	Strap, Front "C" (used on 56315290) NOTE 2
14	56315674	1	Kit, Gum Rubber Squeegee Blade "D" (used on 56315632) NOTE 1
	56315348	1	Kit, Gum Rubber Squeegee Blade "C" (used on 56315290) NOTE 1
15	56471194	1	Latch Assembly
			Squeegee Blade Kits for 56315632
	56315674	1	Kit, Gum Rubber Squeegee Blade "D" NOTE 1
#	56314865	1	Kit, Red Gum Rubber Squeegee Blade "D" NOTE 1
*	56315856	1	Kit, PU Squeegee Blade "D" NOTE 1
			"C" Squeegee Blade Kits for 56315290
	56315348	1	Kit, Gum Rubber Squeegee Blade "C" NOTE 1
#	56315352	1	Kit, Red Gum Rubber Squeegee Blade "C" NOTE 1
*	56315855	1	Kit, PU Squeegee Blade "C" NOTE 1

* = Optional, Not Included

= Revised or new since last update

NOTE 1: All squeegee blade kits include both front and rear squeegee blades.

NOTE 2: To replace squeegee straps on machines without Latch Support 56109554 (item 16) order one of the two following Strap Kits: 56109669-Strap Kit-D (for Squeegee Assy 56315632) or 56109666-Strap Kit-C (for Squeegee Assy 56315290).

These kits include both rear straps, front strap and the latch.

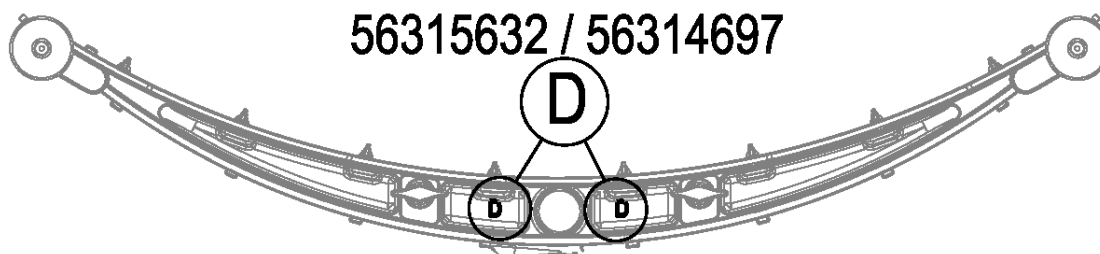
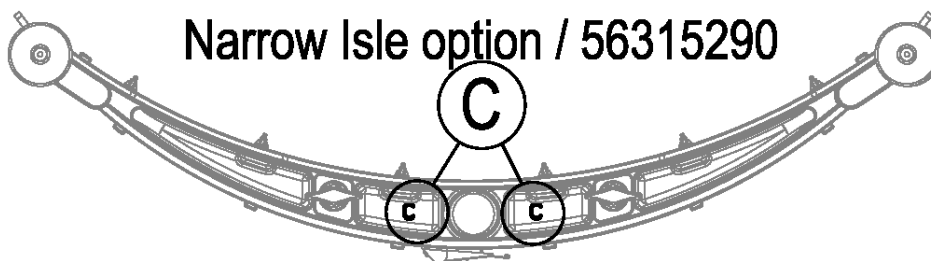

WIRING DIAGRAM

07-9

26

34 RST

10-2

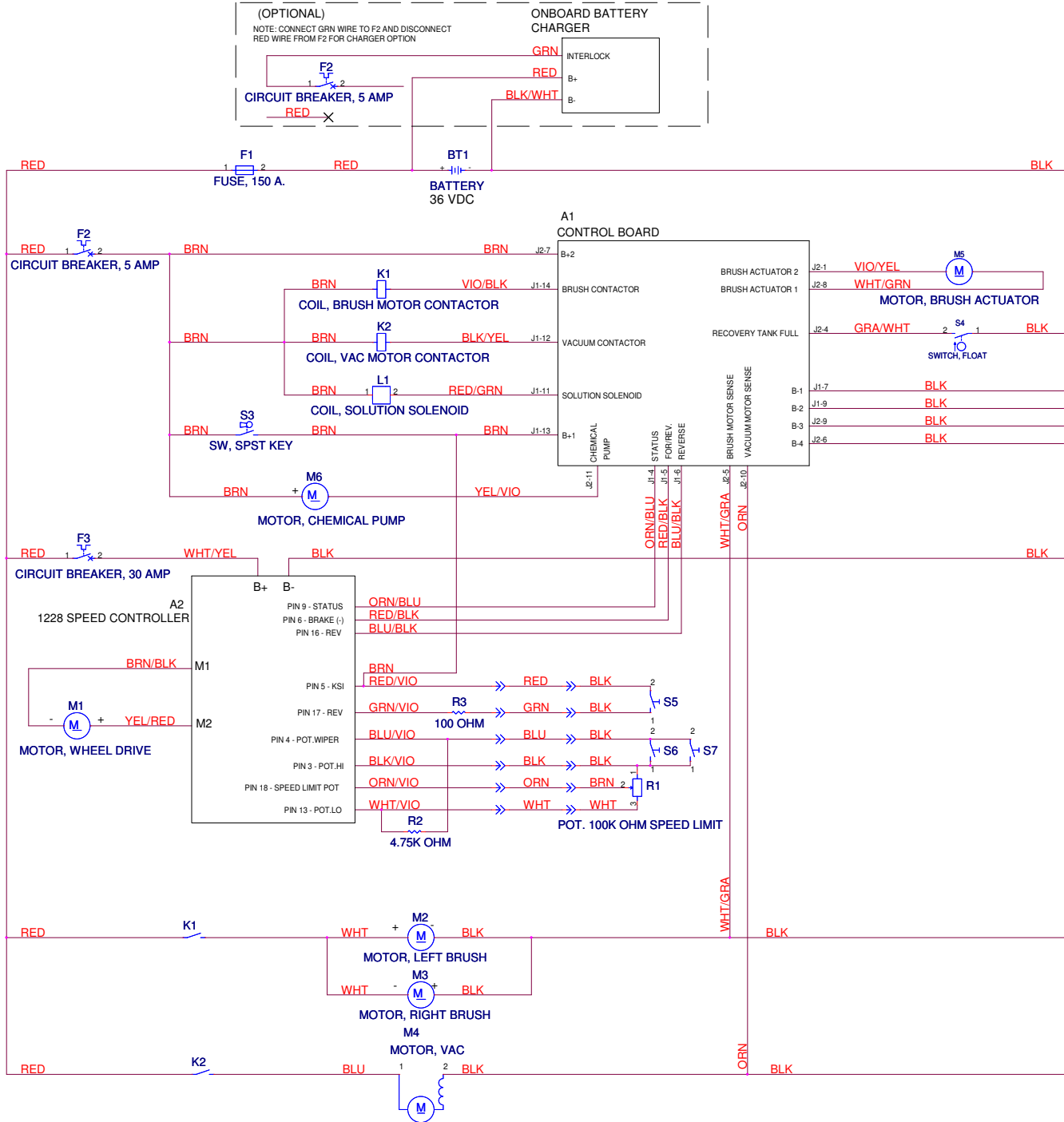

Item	Ref. No.	Qty	Description
A1#	56315924	1	Control Panel Assy (STD)
#	56381082	1	Control Panel Assy (EcoFlex)
A2	56315925	1	Speed Control
BT1	NA	6	Battery
F1	56412089	1	Fuse, 150 Amp
F2	56315255	1	Circuit Breaker, 5 Amp
F3	56315256	1	Circuit Breaker, 30 Amp
K1	56395453	1	Contactora, Brush Motor TSBUS2008-1020
K2	56395455	1	Contactora, Vac Motor
L1	56303275	1	Solenoid, Solution
M1	56315063	1	Transaxle, 36v
[]	56315676	1	Motor
[]	56315677	4	Carbon Brush
[]	56315678	2	Neoprene Mounting Sleeve
M2	56397316	1	Motor, Left Brush TSBUS2010-1059
[]	56397139	4	Carbon Brush NOTE 2
[]	56397138	4	Brush Spring NOTE 2
[]	56380634	1	Carbon Brush/Set of 4 NOTE 2
[]	56380635	1	Brush Spring/Set of 4 NOTE 2
M3	56397316	1	Motor, Right Brush TSBUS2010-1059
[]	56397139	4	Carbon Brush NOTE 2
[]	56397138	4	Brush Spring NOTE 2
[]	56380634	1	Carbon Brush/Set of 4 NOTE 2
[]	56380635	1	Brush Spring/Set of 4 NOTE 2
M4	56391208	1	Vac Motor Assy
[]	56377001	1	Carbon Brush Set of 2
M5	56109597	1	Motor, Brush Actuator TSBUS2009-1040
[]	56109596	1	Plastic Nut
M6	56315241	1	Chemical Pump (Optional)
R1	56315929	1	Potentiometer, 100K Ohm, Speed Limit
R2	N/A	1	Resister, 4.7K Ohm (part of 56315920)
S3	56303553	1	Switch, Key
[]	56303526	A/R	Set of 2 Replacement Keys
S4	56315096	1	Switch, Float
S5	56315945	1	Switch, SPST MOM
S6	56315935	1	Switch, Palm Assy
S7	56315935	1	Switch, Palm Assy
[]	56315204	1	Charger, Onboard 36V (Onboard Charger Models Only) NOTE 1 / TSBUS2007-979 / TSBUS2008-984 / TSBUS2008-1003 / TSBUS2008-1008
[]	56315747	1	Thermister Repair Kit for 56315204
[]	56315920	1	Harness, Main
[]	56315750	1	Vacuum Harness
[]	56416445	3	Cable Assy 4 AWG (Battery Cables)
[]	56456460	2	Cable Assy 4 X 12 (Battery Cables)
[]	56372673	12	Boot, Battery Post
[]	56478246	12	Tie, Cable
[]	56314119	2	Spacer. Battery

[] = Not Shown

= Revised or new since last update

NOTE 1: The charger software can be programmed with a computer and the QuiQ Programmer kit 56315732.**NOTE 2:** If your Motor / Gear Unit Assembly has a serial tag from Imperial Electric order (4) Carbon Brushes 56397139 or (4) Brush Springs 56397138.

If your Motor / Gear Unit Assembly has a serial tag from Nilfisk-Advance order Carbon Brush Set 56380634 or Brush Spring Set 56380635.

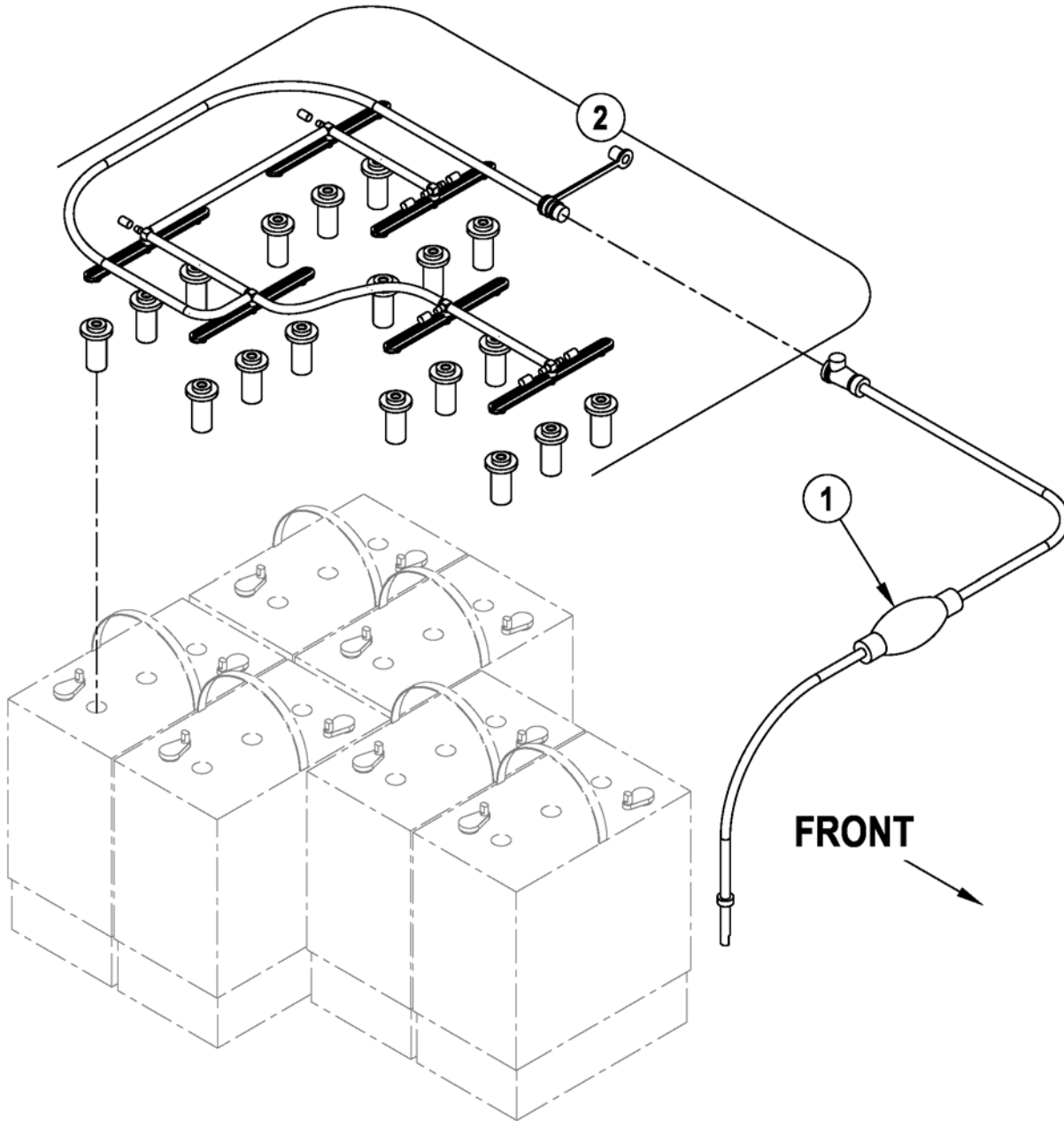

07-9

BATTERY WATERING SYSTEM (MODEL 56315903)

34 RST

29

Item	Ref. No.	Qty	Description
	56314974	1	Battery Watering System (items 1-2) (standard on model 56315903)
	56314981	1	Battery Watering Kit (includes 56314974 and instruction sheet 56040853)
1	56314978	1	Pump
2	56314979	1	Manifold Assembly

OPTIONAL KITS & ACCESSORIES

07-9

30

34 RST

11-2

Ref. No. Qty Description

Options

*	56315732	A/R	QuiQ Programmer Kit NOTE 2 TSBUS2007-979
*	9096219000	2	Wheel, Polyurethane – Traction
*	56314981	A/R	Battery Watering Kit
*	56315290	1	Squeegee Assy "C" (Narrow isle Option)
*#	56314697	1	Squeegee Assy "D" (Red Gum Rubber)
*	56315958	1	Handle Lowering Kit

NOTE: Replacement parts for the kits listed above can be found on each kit's associated instruction sheet.

Kits for Squeegee 56315632

	56315674	1	Kit, Gum Rubber Squeegee Blade "D" NOTE 1
*#	56314865	1	Kit, Red Gum Rubber Squeegee Blade "D" NOTE 1
*	56315856	1	Kit, PU Squeegee Blade "D" NOTE 1
*	56109585	1	Strap Kit-D

Kits for Squeegee 56315290

	56315348	1	Kit, Gum Rubber Squeegee Blade "C" NOTE 1
*#	56315352	1	Kit, Red Gum Rubber Squeegee Blade "C" NOTE 1
*	56315855	1	Kit, PU Squeegee Blade "C" NOTE 1
*	56109584	1	Strap Kit-C

Accessories

*	56315316	A/R	Tote Bag
*	56409441	A/R	Programmer, 1307 User
*	56409823	A/R	Programmer Cable
*	56397453	6	Indicator, Battery Level (1 per battery)
*#	56044407	A/R	Literature Pack (Prior to introduction of EcoFlex)
*#	56044593	A/R	Literature Pack (After introduction of EcoFlex)

Optional Batteries

*	56206117	6	Battery, 6v 195 A/H Wet TSBUS2008-984
*	56206079	6	Battery, 6v 235 A/H Wet TSBUS2008-984
*	56391391	6	Battery, 6v 305 A/H Wet TSBUS2008-984
*	56206987	6	Battery, 6v 180a/H Gel TSBUS2008-984
*	56315959	6	Battery, 6v 315 A/H AGM TSBUS2008-984
*	56315772	6	Battery, 6v 255 A/H Sealed TSBUS2008-984

Optional Battery Chargers

*	56395101	1	Charger, 36vdc Auto 20 Amp 120vac/60hz TSBUS2008-984
*	56388502	1	Charger, 36vdc Auto 25 Amp 120vac/60hz TSBUS2008-984
*	56388120	1	Charger, 36vdc Auto 36 Amp 120vac/60hz TSBUS2008-984
*	56372190	1	Charger, 36vdc 20 Amp 230vac/50hz TSBUS2008-984
*	56388119	1	Charger, 36vdc 36 Amp 230vac/50hz TSBUS2008-984

Optional Brushes

*	56315942	2	Pad Holder-17 Gimbal
*	10384A	2	Brush, Light Grit
*	11430B	2	Brush, Medium Grit
*	11425B	2	Brush, Heavy Grit
*	11424B	2	Brush, Polypropylene
*	10875A	2	Brush, Nylon

* = Optional, Not Included

= Revised or new since last update

NOTE 1: All squeegee blade kits include both front and rear squeegee blades.

NOTE 2: The charger software can be programmed with a computer and the QuiQ Programmer kit 56315732.

We provide brushes and pad holders that will give you the best possible performance between machine and floor. Following are descriptions of the materials and their applications.

- 10384A Lite Grit: Least aggressive grit brush for general medium duty scrubbing on terrazzo, sealed and unsealed concrete, less aggressive than Clean Grit or Super Grit brushes.
- 110430A Clean Grit: Medium duty scrubbing for tough soils on concrete, tile and other resilient floors. Most popular choice of the grit brushes.
- 11425B Super Grit: Most aggressive of the grit brushes for heavy duty scrubbing on hard floors.
- 11424B Polypropylene: Designed for medium-duty scrubbing on concrete, terrazzo and vinyl floor tile.
- 10875A Nylon: For light duty scrubbing applications.

BRUSHES

56315942 - Pad Holder-17 Gimbal
 10384A - Light Grit
 11430B - Medium Grit
 11425B - Heavy Grit
 11424B - Polypropylene
 10875A - Nylon



Advance

14600 21st Avenue North
Plymouth, MN 55447-3408

www.advance-us.com

Phone: 800-989-2235

Fax: 800-989-6566

©2011 Nilfisk-Advance, Inc.

A Nilfisk-Advance Brand